

Product Range International 2017

PP/PE Plastic Piping Systems



List of abbreviations

ANSI	American National Standard	Tg	Malleable Iron
ASTM	American Society for Testing and Materials	d	Pipe outside diameter
BS	British Standard	FM	Fusion Method
DIN	Deutsche Industrie-Normen	DN	Nominal bore
ISO	International Standardization Organisation	PN	Nominal pressure at 20°C, water
ABS	Acrylnitril Butadien Styrene	kg	Weight in kilograms
PVC-U	Polyvinyl Chloride	g	Weight in grams
PVC-C	Polyvinyl Chloride chlorinated	SP	Standard pack. The figure given indicates the quantity of fittings contained in a standard pack
PP	Polypropylene, heat stabilised	GP	Gross pack. The figure given indicates the quantity of fittings contained in a gross pack
PP-N	Polypropylene, Random copolymer unpigmented	G	Pipe thread, not pressure tight in the thread to ISO 228/1
PE	Polyethylene	NPT	Taper male thread pressure tight in the thread to ANSI B 1.20.1
PVDF	Polyvinylidene fluoride	R	Taper male thread, pressure tight in the thread to ISO 7/DIN 2999/1
EPDM	Ethylene Propylene Rubber	Rc	Taper female thread, pressure tight in the thread to ISO 7/1
FPM	Fluorine Rubber, e.g. Viton®	Rp	Parallel female thread, pressure tight in the thread to ISO 7/DIN 999/1
NBR	Nitrile Rubber	Tr	Trapezoid thread
IIR	Butyl Rubber	SC	Size of hexagon bolts
CSM	Chlore Sulphonyl Polythene, e.g. Hypalon®	s	A/F
CR	Chloroprene Rubber, e.g. Neoprene®	e	Wall thickness
PROGEF	GF of PP	AL	Number of bolt holes
PTFE	Polytetrafluorethylene, e.g. Teflon®	®	Registered trade-mark
UP-GF	Unsaturated polyester resin glassfibre reinforced		
St	Steel		
Ms	Brass		

Contents

	Page
PROGEF Standard Pipes, Fittings, Unions, Flanges and Flange Adaptors	11
PROGEF Standard Hand-Operated and Actuated Valves	75
PROGEF Natural Pipes, Fittings, Unions, Flanges and Flange Adaptors	325
PROGEF Natural Hand-Operated and Actuated Valves	337
PROGEF Plus Pipes, Fittings, Unions, Flanges and Flange Adaptors	347
PROGEF Plus Hand-Operated and Actuated Valves	359
PE Industrial Systems Pipes, Fittings, Unions, Flanges and Flange Adaptors	387
Accessories and Spare parts	485
Fusion Jointing Machines	611
Accessories and Tools for Installation and Jointings	638

PROGEF Standard



- Pipes
- Socket Fusion System
- Butt Fusion System

PROGEF® Standard

Pressure/temperature diagram for PP

PP-H

The following pressure/temperature diagrams for PP-H pipes and fittings are valid for a lifetime of 25 years.

The design factor of 2.0 recommended by GF is incorporated.

They can be used for water or media resembling water, in other words, media which have no derating factor regarding the chemical resistance.

Remark: Please take into account the pressure/temperature diagrams for valves and special fittings. Because of the construction and/or sealing material used, differences are possible when compared with pipes and fittings. This information can be found in the planning fundamentals of the relevant types of valves, respectively special fittings.

According to the 10 °C line in the hydrostatic strength curve for PP-H, a permissible pressure of 12.2 bar / 7.4 bar in the temperature range of -10° to +10° C for the PN10 / PN6 system can be applied.

In case of applications with temperatures in the range of the dotted lines please contact your GF representative.

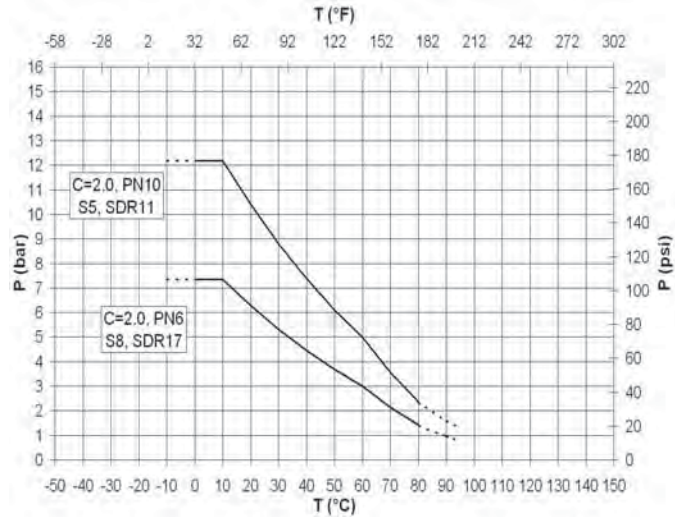

P Permissible pressure in bar, psi
T Temperature in °C, °F

PROGEF Standard – System Specification

Material	Beta PP-H 100 (Beta Polypropylene Homopolymer) d 16 - d 225	State-of-the-art PP (Polypropylene) d 250 - d 500
Colour	RAL 7032 pebble grey	RAL 7032 pebble grey
Density	~0.90g/cm ³ (ISO 1183/ASTM D 792)	~0.90g/cm ³ (ISO 1183 / ASTM D 792)
Surface tension	31 mJ/m ²	24 mJ/m ²
Linear expansion coefficient	0.16mm/mK (DIN 53752)	0.16-0.18mm/mK (DIN 53752)
E-modulus	1300N/mm ² (ISO 527/ASTM D 790)	900N/mm ² (ISO 527/ASTM D 790)
Thermal conductivity	0.23W/mK (EN 12664)	0.23W/mK (EN 12664)
Surface resistivity	> 10 ¹⁶ Ω (IEC 60093)	> 10 ¹⁶ Ω (IEC 60093)
Dimension	d 16 – d 500 in accordance to EN ISO 15494	
Pressure Rating	Pipes/Fittings/Diaphragm and ball valves: d 16 – d 225 SDR11, PN10, c=2.0 d 50 – d 225 SDR17.6, PN6, c=2.0 Butterfly valves: d63–d225, PN10 / d280, PN8 / d315, PN8	Pipes/Fittings: d 250 – d 500 SDR11, PN10, c=2.0 d 250 – d 500 SDR17.6, PN6, c=2.0
Temperature Rating	From 0°C to 80°C (32°F – 176°F)	
Production	Fittings: injection moulded or segment welded Pipes: extruded Valves: injection moulded	
Marking	All components are embossed with a permanent identification during the production process to ensure full traceability: Lot No Material Dimension Pressure Rating	
Testing and Inspection (EN ISO 15494)	Visual inspection Surface finish Dimension tolerance Pressure testing Full product range passed the Initial Type Test (ITT)	
Material- and Product Approvals/Conformance⁽¹⁾	FDA CFR 21 177.1520 USP 25 class VI (physiological non-toxic) DIBt (Z-40.23-4, Z-40.23-264, Z – 40.23-265) DNV (K-2630, K – 2636) Lloyd's Register (01/ 20030(E1))	
Welding Technology	Socket fusion (DVS 2207 - 11): d 16 - d 110 IR Plus, infrared fusion (DVS 2207 - 6): d 20 - d 225 Butt fusion (DVS 2207-11): d 20 - d 500	
Documentation⁽²⁾	EN 10204 2.2 / EN 10204 3.1	
Packing	Pipes and fittings bulk bagged	
Labeling	Brand Name Product Description Code Number Material Dimension CE-labeling ⁽³⁾ Approvals	
Main Applications	PROGEF has been relied to be highly resistant to impact, abrasion and many chemicals. Suitable for industrial applications in chemical production, chemical distribution, galvanisation and power stations.	

⁽¹⁾ For thermoplastic material only

⁽²⁾ On request

⁽³⁾ From 2008 on

PROGEF Standard Pipes, Fittings, Unions, Flanges and Flange Adaptors

		Page
	PP-H Pipes	12
	Butt fusion fittings	14
	Adaptor fittings for butt fusion	33
	SIGNET Sensor installation fittings	37
	Unions for butt fusion	40
	Flange Adaptors, Flanges and Gaskets for Butt Fusion	46
	Fittings for Socket Fusion	56
	Adaptor fittings for socket fusion	59
	Unions for socket fusion	63
	Adaptor Unions for Socket Fusion	66
	Flange Adaptors, Flanges and Gaskets for Socket Fusion	69

PP-H Pipes

67 48 07

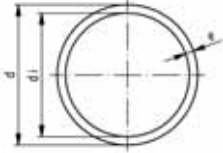

PROGEF Standard pipe S5/SDR11 (PN10)

Model:

- Material: PP-H
- Dimension: DIN 8077
- Colour: RAL 7032 pebble grey
- Length: Lengths of 5 m

* In these two sizes, stiffeners Code No. 727 900 006 (20 x 1.9) and 727 900 007 (25 x 2.3), or pipe SDR 7.4 must be used with socket fusion joints.

d [mm]	PN	Code	kg/m	e [mm]	di [mm]
16	10	167 480 710	0.080	1.8	12.4
* 20	10	167 480 711	0.107	1.9	16.2
* 25	10	167 480 712	0.164	2.3	20.4
32	10	167 480 713	0.261	2.9	26.2
40	10	167 480 714	0.412	3.7	32.6
50	10	167 480 715	0.638	4.6	40.8
63	10	167 480 716	1.010	5.8	51.4
75	10	167 480 717	1.410	6.8	61.4
90	10	167 480 718	2.030	8.2	73.6
110	10	167 480 719	3.010	10.0	90.0
125	10	167 480 720	3.910	11.4	102.2
140	10	167 480 721	4.870	12.7	114.6
160	10	167 480 722	6.380	14.6	130.8
180	10	167 480 723	8.070	16.4	147.2
200	10	167 480 724	9.950	18.2	163.6
225	10	167 480 725	12.600	20.5	184.0
250	10	167 480 726	15.500	22.7	204.6
280	10	167 480 727	19.400	25.4	229.2
315	10	167 480 728	24.600	28.6	257.8
355	10	167 480 729	31.200	32.2	290.6
400	10	167 480 730	39.600	36.3	327.4
450	10	167 480 731	50.200	40.9	368.2
500	10	167 480 732	63.300	45.4	409.2

67 48 10

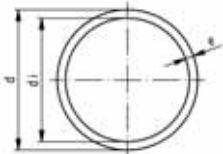

PROGEF Standard pipe S3.2/SDR7.4 (PN16)

Model:

- Material: Polypropylene (PP-H) DIN 8078
- Dimension: DIN 8077
- Colour: RAL 7032 pebble grey
- Length: Lengths of 5 m
- for socket fusion without stiffeners

d [mm]	PN	Code	kg/m	e [mm]	di [mm]
16	16	167 481 027	0.095	2.2	11.6
20	16	167 481 028	0.148	2.8	14.4
25	16	167 481 029	0.230	3.5	18.0

67 48 06

PROGEF Standard pipe S8.3/SDR17.6 (PN6)

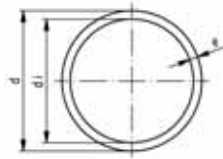

Model:

- Material: PP-H
- Dimension: DIN 8077
- Colour: RAL 7032 pebble grey
- Length: Lengths of 5 m

d [mm]	Code	kg/m	e [mm]	di [mm]
50	167 480 680	0.422	2.9	44.2
63	167 480 681	0.659	3.6	55.8
75	167 480 682	0.935	4.3	66.4
90	167 480 683	1.330	5.1	79.8
110	167 480 684	1.990	6.3	97.4
125	167 480 685	2.550	7.1	110.8
140	167 480 686	3.200	8.0	124.0
160	167 480 687	4.170	9.1	141.8
180	167 480 688	5.250	10.2	159.6
200	167 480 689	6.500	11.4	187.2
225	167 480 690	8.190	12.8	199.4
250	167 480 691	10.100	14.2	221.6
280	167 480 692	12.600	15.9	248.2
315	167 480 693	16.000	17.9	279.2
355	167 480 694	20.300	20.1	314.8
400	167 480 695	25.700	22.7	354.6
450	167 480 696	32.500	25.5	399.0
500	167 480 697	40.200	28.4	443.2

Butt fusion fittings

27 01 86

PROGEF Standard bend 90° S5/SDR11

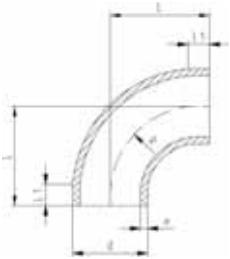

Model:

- Material: PP-H
- Conventional butt-welding according to DVS 2207 part 11
- IR = Infrared-(IR Plus®) compatible. Choose fusion parameters: PP-H

¹ Material: PP-R

d [mm]	FM	Code	kg	L [mm]	L1 [mm]	R [mm]	e [mm]
20	IR	727 018 606	0.008	38	23	15	1.9
25	IR	727 018 607	0.013	42	23	19	2.3
32	IR	727 018 608	0.022	46	22	24	2.9
40	IR	727 018 609	0.040	51	21	30	3.7
50	IR	727 018 610	0.067	58	21	37	4.6
63	IR	727 018 611	0.117	66	21	45	5.8
75	IR	727 018 612	0.232	100	20	90	6.8
90	IR	727 018 613	0.337	100	20	90	8.2
110	IR	727 018 614	0.701	141	25	130	10.0
125	IR	727 018 490	0.927	140	15	125	11.4
140	IR	727 018 491	1.260	155	15	140	12.7
160	IR	727 018 492	2.035	175	15	160	14.6
180	IR	727 018 493	2.669	195	15	180	16.4
200	IR	727 018 494	3.574	215	15	200	18.2
225	IR	727 018 495	5.133	245	20	225	20.5
250	--	727 018 521	6.351	256	48	232	22.7
280	--	727 018 522	9.398	286	48	262	25.4
315	--	727 018 523	12.959	321	48	297	28.6
¹ 355	--	727 018 574	19.400	385	38	355	32.2
¹ 400	--	727 018 575	28.453	438	41	400	36.3

Bend 90°, PP-H S5/SDR11



- For IR, butt- and electro fusion
- Reduction factor = 0,8
- big dimensions on request

d [mm]	Code	L [mm]	L1 [mm]	e [mm]
110	700 649 384	315	150	10,0
125	700 649 385	338	150	11,4
140	700 649 386	360	150	12,8
160	700 649 387	390	150	14,6
180	700 649 388	420	150	16,4
200	700 649 389	450	150	18,2
225	700 649 390	488	150	20,5
250	700 649 391	625	250	22,8
280	700 649 392	670	250	25,5
315	700 649 393	773	300	28,7
355	700 649 394	833	300	32,3
400	700 649 395	900	300	36,4

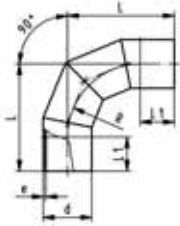

PROGEF Standard bend 90° S5/SDR11

Model:

- Material: PP-H
- Conventional butt-welding according to DVS 2207 part 11
- Production process: segment welded
- Segment-welded fittings have a pressure reduction factor of 0.8

d [mm]	Code	kg	L [mm]	L1 [mm]	R [mm]	e [mm]
450	727 018 576	85.300	975	300	675	40,9
500	727 018 577	121.940	1100	350	750	45,4

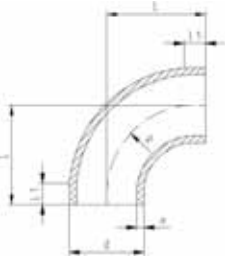

PROGEF Standard bend 90° S8.3/SDR17.6

Model:

- Material: PP-H
- Conventional butt-welding according to DVS 2207 part 11
- IR = Infrared-(IR Plus®) compatible. Choose fusion parameters: PP-H

¹ Material: PP-R

d [mm]	FM	Code	kg	L [mm]	L1 [mm]	R [mm]	e [mm]
50	IR	727 018 635	0.050	58	21	37	2.9
63	IR	727 018 636	0.081	66	21	45	3.6
75	IR	727 018 637	0.164	100	20	90	4.3
90	IR	727 018 638	0.241	100	20	90	5.1
110	IR	727 018 639	0.484	141	25	130	6.3
125	IR	727 018 440	0.638	140	15	125	7.1
140	IR	727 018 441	1.065	155	15	140	8.0
160	IR	727 018 442	1.309	175	15	160	9.1
180	IR	727 018 443	2.138	195	15	180	10.2
200	IR	727 018 444	2.378	215	15	200	11.4
225	IR	727 018 445	3.298	245	20	225	12.8
250	--	727 018 421	4.359	256	48	232	14.2
280	--	727 018 422	6.696	286	48	262	15.9
315	--	727 018 423	8.580	321	48	297	17.9
355	--	727 018 549	13.300	355	15	355	20.1
400	--	727 018 550	18.615	400	25	400	22.7

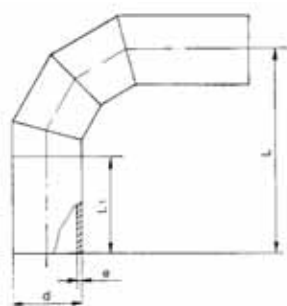

Bend 90°, PP-H S8/SDR17.6

- For IR, butt- and electro fusion
- Reduction factor = 0,8
- big dimensions on request

d [mm]	Code	L [mm]	L1 [mm]	e [mm]
110	700 649 396	315	150	6,3
125	700 649 397	338	150	7,1
140	700 649 398	360	150	8,0
160	700 649 399	390	150	9,1
180	700 649 400	420	150	10,2
200	700 649 401	450	150	11,4
225	700 649 402	488	150	12,8
250	700 649 403	625	250	14,2
280	700 649 404	670	250	15,9
315	700 649 405	773	300	17,9
355	700 649 406	833	300	20,1
400	700 649 407	900	300	22,7



PROGEF Standard bend 90° S8.3/SDR17.6

Model:

- Material: PP-H
- Conventional butt-welding according to DVS 2207 part 11
- Production process: segment welded
- Segment-welded fittings have a pressure reduction factor of 0.8

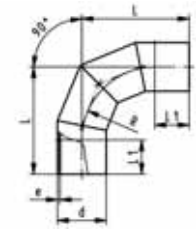

d [mm]	Code	kg	L [mm]	L1 [mm]	e [mm]	R [mm]
450	727 018 551	55.400	975	300	25,5	675
500	727 018 552	77.400	1100	350	28,4	750

27 10 85

PROGEF Standard elbow 90° S5/SDR11

Model:

- Material: PP-H
- Conventional butt-welding according to DVS 2207 part 11
- IR = Infrared-(IR Plus®) compatible. Choose fusion parameters: PP-H

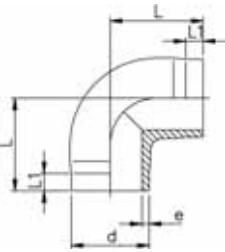

d [mm]	FM	Code	kg	L [mm]	L1 [mm]	e [mm]
20	IR	727 108 506	0.008	38	25	1.9
25	IR	727 108 507	0.012	42	26	2.3
32	IR	727 108 508	0.022	46	27	2.9
40	IR	727 108 509	0.045	51	22	3.7
50	IR	727 108 510	0.080	58	23	4.6
63	IR	727 108 511	0.138	66	21	5.8

27 15 85

PROGEF Standard elbow 45° S5/SDR11

Model:

- Material: PP-H
- Conventional butt-welding according to DVS 2207 part 11
- IR = Infrared-(IR Plus®) compatible. Choose fusion parameters: PP-H
- Long version for d250, d280 and d315

¹ Material: PP-R

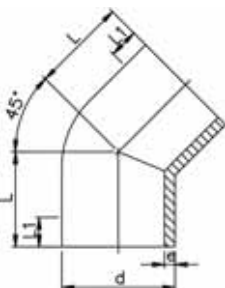

d [mm]	FM	Code	kg	L [mm]	L1 [mm]	e [mm]
20	IR	727 158 506	0.006	32	24	1.9
25	IR	727 158 507	0.010	34	25	2.3
32	IR	727 158 508	0.021	36	25	2.9
40	IR	727 158 509	0.033	39	25	3.7
50	IR	727 158 510	0.054	42	26	4.6
63	IR	727 158 511	0.097	47	29	5.8
75	IR	727 158 512	0.137	49	29	6.8
90	IR	727 158 513	0.222	57	34	8.2
110	IR	727 158 514	0.412	70	43	10.0
125	IR	727 158 515	0.570	79	48	11.4
140	IR	727 158 516	0.854	88	55	12.7
160	IR	727 158 517	1.256	100	60	14.6
200	IR	727 158 519	2.448	124	75	18.2
225	IR	727 158 520	3.495	140	85	20.5
¹ 250	--	727 158 521	7.890	225	133	22.7
¹ 280	--	727 158 522	10.170	235	143	25.4
¹ 315	--	727 158 523	11.690	255	154	28.6

27 15 85

PROGEF Standard bend 45° S5/SDR11**Model:**

- Material: PP-H
- Conventional butt-welding according to DVS 2207 part 11
- Production process: segment welded
- Segment-welded fittings have a pressure reduction factor of 0.8

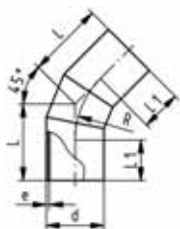

d [mm]	Code	kg	L [mm]	L1 [mm]	e [mm]	R [mm]
355	727 158 524	32.300	520	300	32,2	532.5
400	727 158 525	43.200	548	300	36,3	600.0
450	727 158 526	57.700	580	300	40,9	675.0
500	727 158 527	87.200	665	350	45,4	750.0

27 15 85

PROGEF Standard elbow 45° S8.3/SDR17.6**Model:**

- Material: PP-H
- Conventional butt-welding according to DVS 2207 part 11
- IR = Infrared-(IR Plus®) compatible. Choose fusion parameters: PP-H

¹ Material: PP-R

*Machined from S5/SDR11

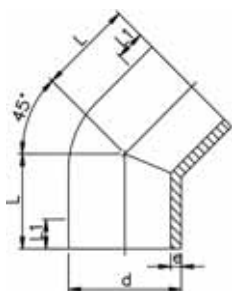

d [mm]	FM	Code	kg	L [mm]	L1 [mm]	e [mm]
* 50	IR	727 158 535	0.042	42	26	2,9
* 63	IR	727 158 536	0.081	47	29	3,6
75	IR	727 158 412	0.099	49	29	4,3
90	IR	727 158 413	0.164	57	34	5,1
110	IR	727 158 414	0.286	70	43	6,3
* 125	IR	727 158 540	0.570	79	48	7,1
* 140	IR	727 158 541	0.721	88	55	8,0
* 160	IR	727 158 542	1.107	100	60	9,1
* 200	IR	727 158 544	2.225	124	75	11,4
* 225	IR	727 158 545	3.194	140	85	12,8
1 250	--	727 158 546	4.970	225	133	14,2
1 280	--	727 158 547	7.130	235	143	15,9
1 315	--	727 158 548	9.600	255	154	17,9

Bend 45°, PP-H S5/SDR11

- For IR, butt- and electro fusion
- Reduction factor = 0,8
- big dimensions on request

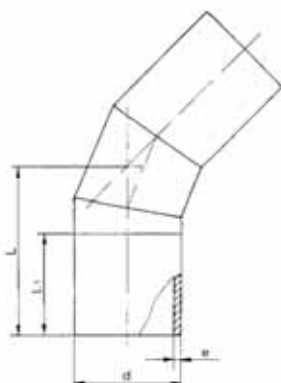

d [mm]	Code	L [mm]	L1 [mm]	e [mm]
110	700 649 444	218	150	10,0
125	700 649 445	228	150	11,4
140	700 649 446	237	150	12,8
160	700 649 447	249	150	14,6
180	700 649 448	262	150	16,4
200	700 649 449	274	150	18,2
225	700 649 450	290	150	20,5
250	700 649 451	412	250	22,8
280	700 649 452	424	250	25,5
315	700 649 453	498	300	28,7
355	700 649 454	520	300	32,3
400	700 649 455	548	300	36,4

Bend 45°, PP-H S8/SDR17.6

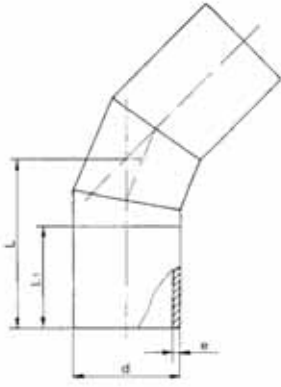

- For IR, butt- and electro fusion
- Reduction factor = 0,8
- big dimensions on request

d [mm]	Code	L [mm]	L1 [mm]	e [mm]
110	700 649 432	218	150	6,3
125	700 649 433	228	150	7,1
140	700 649 434	237	150	8,0
160	700 649 435	249	150	9,1
180	700 649 436	262	150	10,2
200	700 649 437	274	150	11,4
225	700 649 438	290	150	12,8
250	700 649 439	412	250	14,2
280	700 649 440	424	250	15,9
315	700 649 441	498	300	17,9
355	700 649 442	520	300	20,1
400	700 649 443	548	300	22,7

27 15 85

PROGEF Standard bend 45° S8.3/SDR17.6

Model:

- Material: PP-H
- Conventional butt-welding according to DVS 2207 part 11
- Production process: segment welded
- Segment-welded fittings have a pressure reduction factor of 0.8

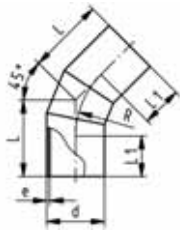

d [mm]	Code	kg	L [mm]	L1 [mm]	e [mm]	R [mm]
355	727 158 549	21.000	520	300	20,1	532.5
400	727 158 550	28.100	548	300	22,7	600.0
450	727 158 551	37.400	580	300	25,5	675.0
500	727 158 552	52.600	665	350	28,4	750.0

Bend 60°, PP-H S5/SDR11

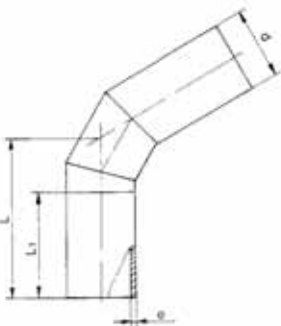

- For IR, butt- and electro fusion
- Reduction factor = 0,8
- big dimensions on request

d [mm]	Code	L [mm]	L1 [mm]	e [mm]
110	700 649 420	245	150	10,0
125	700 649 421	258	150	11,4
140	700 649 422	271	150	12,8
160	700 649 423	288	150	14,6
180	700 649 424	305	150	16,4
200	700 649 425	323	150	18,2
225	700 649 426	345	150	20,5
250	700 649 427	466	250	22,8
280	700 649 428	492	250	25,5
315	700 649 429	576	300	28,7
355	700 649 430	608	300	32,3
400	700 649 431	646	300	36,4

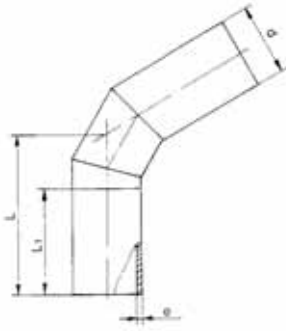

Bend 60°, PP-H S8/SDR17.6

- For IR, butt- and electro fusion
- Reduction factor = 0,8
- big dimensions on request

d [mm]	Code	L [mm]	L1 [mm]	e [mm]
110	700 649 408	245	150	6,3
125	700 649 409	258	150	7,1
140	700 649 410	271	150	8,0
160	700 649 411	288	150	9,1
180	700 649 412	305	150	10,2
200	700 649 413	323	150	11,4
225	700 649 414	345	150	12,8
250	700 649 415	466	250	14,2
280	700 649 416	492	250	15,9
315	700 649 417	576	300	17,9
355	700 649 418	608	300	20,1
400	700 649 419	646	300	22,7

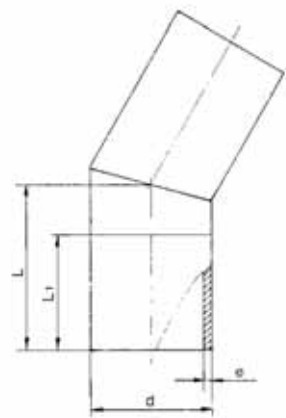

Bend 30°, PP-H S5/SDR11

- For IR, butt- and electro fusion
- Reduction factor = 0,8
- big dimensions on request

d [mm]	Code	L [mm]	L1 [mm]	e [mm]
110	700 649 469	194	150	10,0
125	700 649 470	200	150	11,4
140	700 649 471	206	150	12,8
160	700 649 472	214	150	14,6
180	700 649 473	222	150	16,4
200	700 649 474	230	150	18,2
225	700 649 475	241	150	20,5
250	700 649 476	350	250	22,8
280	700 649 477	362	250	25,5
315	700 649 478	428	300	28,7
355	700 649 479	443	300	32,3
400	700 649 480	461	300	36,4

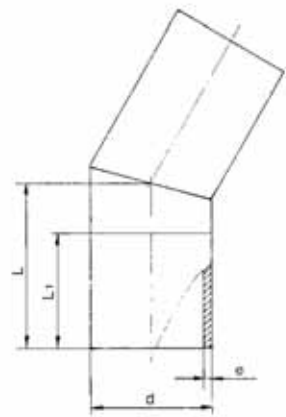

Bend 30°, PP-H S8/SDR17.6

- For IR, butt- and electro fusion
- Reduction factor = 0,8
- big dimensions on request

d [mm]	Code	L [mm]	L1 [mm]	e [mm]
110	700 649 457	194	150	6,3
125	700 649 458	200	150	7,1
140	700 649 459	206	150	8,0
160	700 649 460	214	150	9,1
180	700 649 461	222	150	10,2
200	700 649 462	230	150	11,4
225	700 649 463	241	150	12,8
250	700 649 464	350	250	14,2
280	700 649 465	362	250	15,9
315	700 649 466	428	300	17,9
355	700 649 467	443	300	20,1
400	700 649 468	461	300	22,7

27 20 85

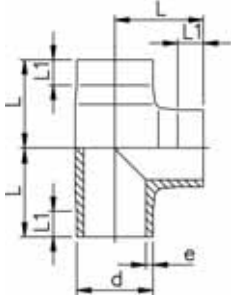
PROGEF Standard tee 90° equal S5/SDR11**Model:**

- Material: PP-H
- Conventional butt-welding according to DVS 2207 part 11
- IR = Infrared-(IR Plus®) compatible. Choose fusion parameters: PP-H

¹ Material: PP-R

d [mm]	FM	Code	kg	L [mm]	L1 [mm]	e [mm]
20	IR	727 208 506	0.011	38	24	1.9
25	IR	727 208 507	0.018	42	26	2.3
32	IR	727 208 508	0.032	46	26	2.9
40	IR	727 208 509	0.062	51	22	3.7
50	IR	727 208 510	0.105	58	22	4.6
63	IR	727 208 511	0.186	66	21	5.8
75	IR	727 208 512	0.293	75	20	6.8
90	IR	727 208 513	0.521	90	20	8.2
110	IR	727 208 514	0.928	110	20	10.0
125	IR	727 208 515	1.347	125	25	11.4
140	IR	727 208 516	1.923	140	28	12.7
160	IR	727 208 517	2.844	160	28	14.6
180	IR	727 208 568	4.844	194	74	16.4
200	IR	727 208 519	5.579	200	35	18.2
225	IR	727 208 520	7.812	220	35	20.5
250	--	727 208 571	12.380	276	92	22.7
280	--	727 208 572	17.735	318	110	25.4
315	--	727 208 573	18.214	353	118	28.6
355	--	727 208 574	31.100	345	103	32.2
400	--	727 208 575	38.000	360	105	36.3
450	--	727 208 576	58.000	419	135	40.9
500	--	727 208 577	73.000	465	160	45.4

27 20 85

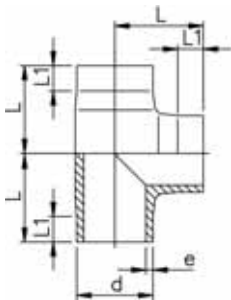
PROGEF Standard tee 90° equal S8.3/SDR17.6**Model:**

- Material: PP-H
- Conventional butt-welding according to DVS 2207 part 11
- IR = Infrared-(IR Plus®) compatible. Choose fusion parameters: PP-H

¹ Material: PP-R

d [mm]	FM	Code	kg	L [mm]	L1 [mm]	e [mm]
50	IR	727 208 535	0.079	59	26	2,9
63	IR	727 208 536	0.178	73	31	3,6
75	IR	727 208 412	0.212	75	20	4,3
90	IR	727 208 413	2.200	90	20	5,1
110	IR	727 208 414	0.705	110	20	6,3
125	IR	727 208 540	1.077	125	30	7,1
140	IR	727 208 541	1.478	140	35	8,0
160	IR	727 208 542	2.264	160	43	9,1
180	IR	727 208 543	3.343	194	70	10,2
200	IR	727 208 544	4.902	210	70	11,4
225	IR	727 208 545	6.889	235	82	12,8
250	--	727 208 546	9.325	276	92	14,2
280	--	727 208 547	13.463	318	110	15,9
315	--	727 208 548	18.000	353	118	17,9
355	--	727 208 549	21.000	345	103	20,1
400	--	727 208 550	26.000	360	105	22,7
450	--	727 208 551	44.400	419	135	25,5
500	--	727 208 552	60.284	476	165	28,4

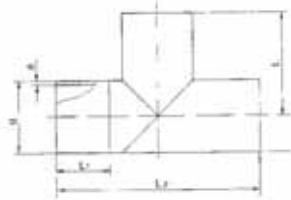

Tees 90°, equal, PP-H S5/SDR11

- For IR, butt- and electro fusion
- Reducing factor = 0,6
- big dimensions on request

d [mm]	Code	L [mm]	L1 [mm]	L2 [mm]	e [mm]
225	700 649 481	265	150	530	20,5
250	700 649 482	375	250	750	22,8
280	700 649 483	390	250	780	25,5
315	700 649 484	460	300	920	28,7
355	700 649 485	480	300	960	32,3
400	700 649 486	500	300	1000	36,4

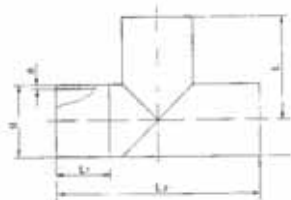

Tees 90°, equal, PP-H S8/SDR17.6

- For IR, butt- and electro fusion
- Reducing factor = 0,6
- big dimensions on request

d [mm]	Code	L [mm]	L1 [mm]	L2 [mm]	e [mm]
225	700 649 487	265	150	530	12,8
250	700 649 488	375	250	750	14,2
280	700 649 489	390	250	780	15,9
315	700 649 490	460	300	920	17,9
355	700 649 491	480	300	960	20,1
400	700 649 492	500	300	1000	22,7

27 20 83

PROGEF Standard tee 90° reduced S5/SDR11

Model:

- Material: PP-H
 - Conventional butt-welding according to DVS 2207 part 11
 - IR = Infrared-(IR Plus®) compatible. Choose fusion parameters: PP-H
- ¹with IR welded reducer

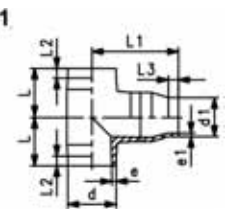
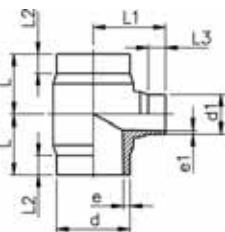

d [mm]	d1 [mm]	FM	Code	kg	L [mm]	L1 [mm]	L2 [mm]	L3 [mm]	e [mm]	e1 [mm]
63	32	IR	727 208 351	0.161	65	70	25	25	5.8	2.9
63	50	IR	727 208 352	0.170	65	70	25	25	5.8	4.6
75	32	IR	727 208 353	0.238	70	75	25	25	6.8	2.9
75	50	IR	727 208 354	0.249	70	75	25	25	6.8	4.6
75	63	IR	727 208 355	0.258	70	75	25	25	6.8	5.8
90	50	IR	727 208 357	0.420	80	85	25	25	8.2	4.6
90	63	IR	727 208 358	0.428	80	85	25	25	8.2	5.8
90	75	IR	727 208 359	0.430	80	85	25	25	8.2	6.8
110	32	IR	727 208 360	0.652	90	95	30	25	10.0	2.9
110	50	IR	727 208 361	0.659	90	95	30	25	10.0	4.6
110	63	IR	727 208 362	0.665	90	95	30	25	10.0	5.8
110	75	IR	727 208 363	0.681	90	95	30	25	10.0	6.8
110	90	IR	727 208 364	0.701	90	95	30	25	10.0	8.2
¹ 125	63	IR	727 208 365	1.680	125	232	25	16	11.4	5.8
¹ 125	90	IR	727 208 366	1.520	125	228	25	22	11.4	8.2
¹ 125	110	IR	727 208 367	1.700	125	220	25	30	11.4	10.0
¹ 140	75	IR	727 208 368	2.140	140	258	28	19	12.7	6.8
¹ 140	90	IR	727 208 369	2.150	140	250	28	22	12.7	8.2
¹ 140	110	IR	727 208 370	2.380	140	245	28	33	12.7	10.0
160	63	IR	727 208 371	2.130	142	135	50	30	14.6	5.8
160	75	IR	727 208 372	2.143	142	135	50	30	14.6	6.8
160	90	IR	727 208 373	2.148	142	135	50	30	14.6	8.2
160	110	IR	727 208 374	2.186	142	135	50	30	14.6	10.0
¹ 160	125	IR	727 208 375	3.500	160	279	28	32	14.6	11.4
¹ 200	160	IR	727 208 385	6.632	200	295	35	40	18.2	14.6
¹ 200	180	IR	727 208 386	6.200	200	345	35	45	18.2	16.4
225	90	IR	727 208 388	4.576	155	165	40	30	20.5	8.2
225	110	IR	727 208 389	4.624	155	165	40	30	20.5	10.0
225	160	IR	727 208 391	4.685	155	165	40	30	20.5	14.6
¹ 250	160		727 208 393	4.530	276	424	92	55	22.7	14.6

PROGEF Standard tee 90° reduced S8.3/SDR17.6**Model:**

- Material: PP-H
- Conventional butt-welding according to DVS 2207 part 11
- IR = Infrared-(IR Plus®) compatible. Choose fusion parameters: PP-H

¹with IR welded reducer

* Branch SDR11

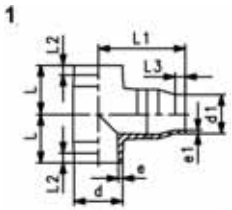
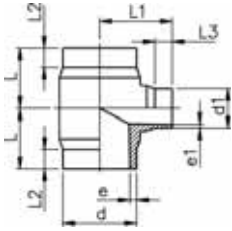

d [mm]	d1 [mm]	FM	Code	kg	L [mm]	L1 [mm]	L2 [mm]	L3 [mm]	e [mm]	e1 [mm]
* 63	32	IR	727 208 301	0.120	65	70	25	25	3,6	2,9
63	50	IR	727 208 302	0.124	65	70	25	25	3,6	2,9
* 75	32	IR	727 208 303	0.178	70	75	25	25	4,3	2,9
75	50	IR	727 208 304	0.182	70	75	25	25	4,3	2,9
75	63	IR	727 208 305	0.190	70	75	25	25	4,3	3,6
90	50	IR	727 208 307	0.305	80	85	25	25	5,1	2,9
90	63	IR	727 208 308	0.315	80	85	25	25	5,1	3,6
90	75	IR	727 208 309	0.320	80	85	25	25	5,1	4,3
* 110	32	IR	727 208 310	0.489	90	95	30	25	6,3	2,9
110	50	IR	727 208 311	0.490	90	95	30	25	6,3	2,9
110	63	IR	727 208 312	0.491	90	95	30	25	6,3	3,6
110	75	IR	727 208 313	0.500	90	95	30	25	6,3	4,3
110	90	IR	727 208 314	0.514	90	95	30	25	6,3	5,1
160	63	IR	727 208 321	1.535	142	135	50	30	9,1	3,6
160	75	IR	727 208 322	1.550	142	135	50	30	9,1	4,3
160	90	IR	727 208 323	1.567	142	135	50	30	9,1	5,1
160	110	IR	727 208 324	1.577	142	135	50	30	9,1	6,3
225	90	IR	727 208 338	3.350	155	165	40	30	12,8	5,1
225	110	IR	727 208 339	3.330	155	165	40	30	12,8	6,3
225	160	IR	727 208 341	3.427	155	165	40	30	12,8	9,1

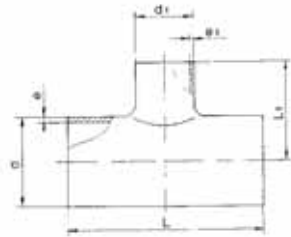

Tee 90°, reduced, PP-H S5/SDR11

- For IR, butt- and electro fusion
- Reducing factor = 0,6
- big dimensions on request

d [mm]	d1 [mm]	Code	L [mm]	L1 [mm]	e [mm]	e1 [mm]
225	63	700 649 493	363	238	20,5	5,8
225	75	700 649 494	375	238	20,5	6,9
225	90	700 649 495	390	238	20,5	8,2
225	110	700 649 496	410	238	20,5	10,0
225	125	700 649 497	425	238	20,5	11,4
225	140	700 649 498	440	238	20,5	12,8
225	160	700 649 499	460	238	20,5	14,6
250	75	700 649 500	475	250	22,8	6,9
250	90	700 649 501	490	250	22,8	8,2
250	110	700 649 502	510	250	22,8	10,0
250	125	700 649 503	525	250	22,8	11,4
250	140	700 649 504	540	250	22,8	12,8
250	160	700 649 505	560	250	22,8	14,6
250	180	700 649 506	580	275	22,8	16,4
280	75	700 649 507	475	265	25,5	6,9
280	90	700 649 508	490	265	25,5	8,2
280	110	700 649 509	510	265	25,5	10,0
280	125	700 649 510	525	265	25,5	11,4
280	140	700 649 511	540	265	25,5	12,8
280	160	700 649 512	560	265	25,5	14,6
280	180	700 649 513	580	290	25,5	16,4
280	200	700 649 514	600	290	25,5	18,2
315	90	700 649 515	490	283	28,7	8,2
315	110	700 649 516	510	283	28,7	10,0
315	125	700 649 517	525	283	28,7	11,4
315	140	700 649 518	540	283	28,7	12,8
315	160	700 649 519	560	283	28,7	14,6
315	180	700 649 520	580	308	28,7	16,4
315	200	700 649 521	600	308	28,7	18,2
315	225	700 649 523	625	308	28,7	20,5
355	110	700 649 524	510	303	32,3	10,0
355	125	700 649 525	525	303	32,3	11,4
355	140	700 649 526	540	303	32,3	12,8
355	160	700 649 527	560	303	32,3	14,6
355	180	700 649 528	580	328	32,3	16,4
355	200	700 649 529	600	328	32,3	18,2
355	225	700 649 530	625	328	32,3	20,5
355	250	700 649 531	650	378	32,3	22,8
400	110	700 649 532	510	325	36,4	10,0
400	125	700 649 533	525	325	36,4	11,4
400	140	700 649 534	540	325	36,4	12,8
400	160	700 649 535	560	325	36,4	14,6
400	180	700 649 536	580	350	36,4	16,4
400	200	700 649 537	600	350	36,4	18,2
400	225	700 649 538	625	350	36,4	20,5
400	250	700 649 539	650	400	36,4	22,8
400	280	700 649 540	680	400	36,4	25,5

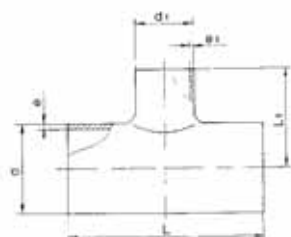

Tee 90°, reduced, PP-H S8/SDR17.6

- For IR, butt- and electro fusion
- Reducing factor = 0,6
- big dimensions on request

d [mm]	d1 [mm]	Code	L [mm]	L1 [mm]	e [mm]	e1 [mm]
225	63	700 649 541	363	238	12,8	3,6
225	75	700 649 542	375	238	12,8	4,3
225	90	700 649 543	390	238	12,8	5,1
225	110	700 649 544	410	238	12,8	6,3
225	125	700 649 545	425	238	12,8	7,1
225	140	700 649 546	440	238	12,8	8,0

table continued next page

d [mm]	d1 [mm]	Code	L [mm]	L1 [mm]	e [mm]	e1 [mm]
225	160	700 649 547	460	238	12,8	9,1
250	75	700 649 548	475	250	14,2	4,3
250	90	700 649 549	490	250	14,2	5,1
250	110	700 649 550	510	250	14,2	6,3
250	125	700 649 551	525	250	14,2	7,1
250	140	700 649 552	540	250	14,2	8,0
250	160	700 649 553	560	250	14,2	9,1
250	180	700 649 554	580	275	14,2	10,2
280	75	700 649 555	475	265	15,9	4,3
280	90	700 649 556	490	265	15,9	5,1
280	110	700 649 557	510	265	15,9	6,3
280	125	700 649 558	525	265	15,9	7,1
280	140	700 649 559	540	265	15,9	8,0
280	160	700 649 560	560	265	15,9	9,1
280	180	700 649 561	580	290	15,9	10,2
280	200	700 649 562	600	290	15,9	11,4
315	90	700 649 563	490	283	17,9	5,1
315	110	700 649 564	510	283	17,9	6,3
315	125	700 649 565	525	283	17,9	7,1
315	140	700 649 566	540	283	17,9	8,0
315	160	700 649 567	560	283	17,9	9,1
315	180	700 649 568	580	308	17,9	10,2
315	200	700 649 569	600	308	17,9	11,4
315	225	700 649 570	625	308	17,9	12,8
355	110	700 649 571	510	303	20,1	6,3
355	125	700 649 572	525	303	20,1	7,1
355	140	700 649 573	540	303	20,1	8,0
355	160	700 649 574	560	303	20,1	9,1
355	180	700 649 575	580	328	20,1	10,2
355	200	700 649 576	600	328	20,1	11,4
355	225	700 649 577	625	328	20,1	12,8
355	250	700 649 578	650	378	20,1	14,2
400	110	700 649 579	510	325	22,7	6,3
400	125	700 649 580	525	325	22,7	7,1
400	140	700 649 581	540	325	22,7	8,0
400	160	700 649 582	560	325	22,7	9,1
400	180	700 649 583	580	350	22,7	10,2
400	200	700 649 584	600	350	22,7	11,4
400	225	700 649 585	625	350	22,7	12,8
400	250	700 649 586	650	400	22,7	14,2
400	280	700 649 587	680	400	22,7	15,9

Branch 45°, PP-H S5/SDR11

- For IR, butt- and electro fusion
- Reduction factor = 0,5

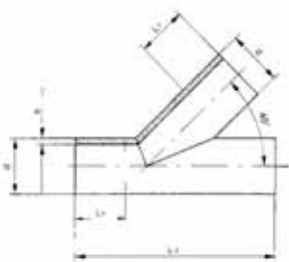

d [mm]	Code	L1 [mm]	L2 [mm]	e [mm]
110	700 649 636	150	520	10,0
125	700 649 637	150	520	11,4
140	700 649 638	150	570	12,8
160	700 649 639	150	640	14,6
180	700 649 640	150	700	16,4
200	700 649 641	150	800	18,2
225	700 649 642	150	800	20,5
250	700 649 643	250	1000	22,8
280	700 649 644	250	1000	25,5
315	700 649 645	300	1300	28,7
355	700 649 646	300	1500	32,3
400	700 649 647	300	1500	36,4

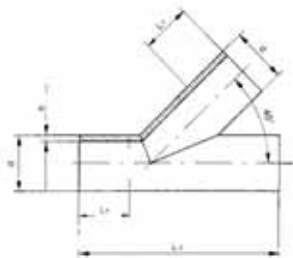

Branch 45°, PP-H S8/SDR17.6

- For IR, butt- and electro fusion
- Reduction factor = 0,5

d [mm]	Code	L1 [mm]	L2 [mm]	e [mm]
110	700 649 648	150	520	6,3
125	700 649 649	150	520	7,1
140	700 649 650	150	570	8,0
160	700 649 651	150	640	9,1
180	700 649 652	150	700	10,2
200	700 649 653	150	800	11,4
225	700 649 654	150	800	12,8
250	700 649 655	250	1000	14,2
280	700 649 656	250	1000	15,9
315	700 649 657	300	1300	17,9
355	700 649 658	300	1500	20,1
400	700 649 659	300	1500	22,7

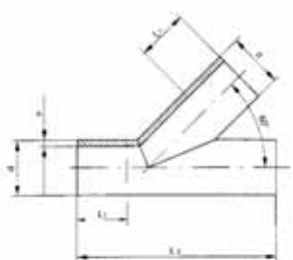

Branch 60°, PP-H S5/SDR11

- For IR, butt- and electro fusion
- Reduction factor = 0,5

d [mm]	Code	L1 [mm]	L2 [mm]	e [mm]
110	700 649 660	150	520	10,0
125	700 649 661	150	520	11,4
140	700 649 662	150	570	12,8
160	700 649 663	150	640	14,6
180	700 649 664	150	700	16,4
200	700 649 665	150	800	18,2
225	700 649 666	150	800	20,5
250	700 649 667	250	1000	22,8
280	700 649 668	250	1000	25,5
315	700 649 669	300	1300	28,7
355	700 649 670	300	1500	32,3
400	700 649 671	300	1500	36,4

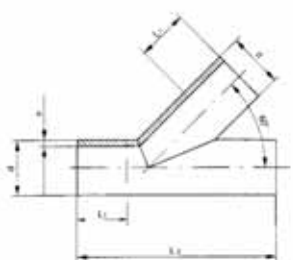

Branch 60°, PP-H S8/SDR17.6

- For IR, butt- and electro fusion
- Reduction factor = 0,5

d [mm]	Code	L1 [mm]	L2 [mm]	e [mm]
110	700 649 672	150	520	6,3
125	700 649 673	150	520	7,1
140	700 649 674	150	570	8,0
160	700 649 675	150	640	9,1
180	700 649 676	150	700	10,2
200	700 649 677	150	800	11,4
225	700 649 678	150	800	12,8
250	700 649 679	250	1000	14,2
280	700 649 680	250	1000	15,9
315	700 649 681	300	1300	17,9
355	700 649 682	300	1500	20,1
400	700 649 683	300	1500	22,7

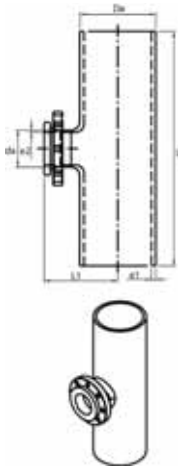

Revision Tees 90°, PP-H SDR11

Model:

- Flued and butt fusion according to DVS2207
- Backing Flanges to ISO 7005, EN 1092, DIN 2501, bolt circle PN 10
- Reducing factor = 0,6
- big dimensions on request

d [mm]	d1 [mm]	PN	Code	L [mm]	L1 [mm]	e1 [mm]	e2 [mm]
110	110	10	700 665 628	500	236	10,0	10,0
125	125	10	700 665 629	500	248	11,4	11,4
140	140	10	700 665 630	500	265	12,7	12,7
160	110	10	700 665 631	500	278	14,6	10,0
180	110	10	700 665 632	500	350	16,4	10,0
200	140	10	700 665 633	500	350	18,2	12,7
225	140	10	700 665 634	560	400	20,5	12,7
250	160	10	700 665 635	750	450	22,7	14,6
280	225	10	700 665 636	750	350	25,4	20,5
315	225	10	700 665 637	850	400	28,6	20,5
355	225	10	700 665 638	950	450	32,2	20,5
400	225	10	700 665 639	1000	450	36,3	20,5

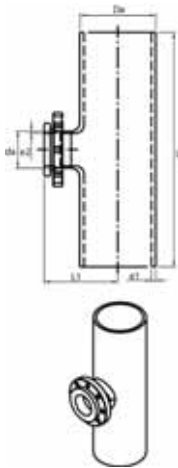

Revision Tees 90°, PP-H SDR17.6

Model:

- Flued and butt fusion according to DVS2207
- Backing Flanges to ISO 7005, EN 1092, DIN 2501, bolt circle PN 10
- Reducing factor = 0,6
- big dimensions on request

d [mm]	d1 [mm]	PN	Code	L [mm]	L1 [mm]	e1 [mm]	e2 [mm]
110	110	6	700 647 267	500	236	6,3	6,3
125	125	6	700 647 268	500	248	7,1	7,1
140	140	6	700 647 269	500	265	8,0	8,0
160	110	6	700 647 270	500	278	9,1	6,3
180	110	6	700 665 644	500	350	10,2	6,3
200	140	6	700 665 645	500	350	11,4	8,0
225	140	6	700 665 646	560	400	12,8	8,0
250	160	6	700 665 647	750	450	14,2	9,1
280	225	6	700 665 648	750	350	15,9	12,8
315	225	6	700 665 649	850	400	17,9	12,8
355	225	6	700 665 650	950	450	20,1	12,8
400	225	6	700 665 651	1000	450	22,7	12,8
450	315	6	700 665 652	1100	500	25,5	17,9
500	315	6	700 665 653	1200	500	28,4	17,9
560	315	6	700 665 654	1300	550	31,7	17,9
630	315	6	700 665 655	1450	550	35,7	17,9

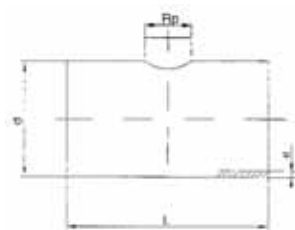

Saddle-Tee, PP-H S5/SDR11 Outlet with female thread Rp, welded

- For IR, butt- and electro fusion
- Reduction factor = 0,8
- big dimensions on request

d [mm]	Thread 1 Code	Thread 11/4 Code	L [mm]	e [mm]
110	700 649 588	700 649 600	260	10,0
125	700 649 589	700 649 601	260	11,4
140	700 649 590	700 649 602	260	12,8
160	700 649 591	700 649 603	260	14,6
180	700 649 592	700 649 604	360	16,4
200	700 649 593	700 649 605	360	18,2
225	700 649 594	700 649 606	360	20,5
250	700 649 595	700 649 607	360	22,8
280	700 649 596	700 649 608	360	25,5

table continued next page

d [mm]	Thread 1 Code	Thread 11/4 Code	L [mm]	e [mm]
315	700 649 597	700 649 609	360	28,7
355	700 649 598	700 649 610	460	32,3
400	700 649 599	700 649 611	460	36,4

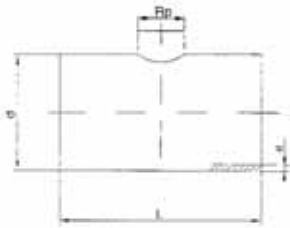

Saddle-Tee, PP-H S8/SDR17.6 Outlet with female thread Rp, welded

- For IR, butt- and electro fusion
- Reduction factor = 0,8
- big dimensions on request

d [mm]	Thread 1" Code	Thread 11/4" Code	L [mm]	e [mm]
110	700 649 612	700 649 624	260	6,3
125	700 649 613	700 649 625	260	7,1
140	700 649 614	700 649 626	260	8,0
160	700 649 615	700 649 627	260	9,1
180	700 649 616	700 649 628	360	10,2
200	700 649 617	700 649 629	360	11,4
225	700 649 618	700 649 630	360	12,8
250	700 649 619	700 649 631	360	14,2
280	700 649 620	700 649 632	360	15,9
315	700 649 621	700 649 633	360	17,9
355	700 649 622	700 649 634	460	20,1
400	700 649 623	700 649 635	460	22,7

27 90 89



PROGEF Standard reducer S5/SDR11

Model:

- Material: PP-H
- Conventional butt-welding according to DVS 2207 part 11
- IR = Infrared-(IR Plus®) compatible. Choose fusion parameters: PP-H

¹ Material: PP-R

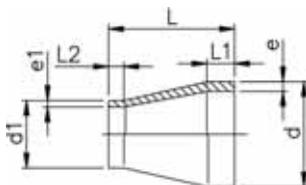

d [mm]	d1 [mm]	FM	Code	kg	L [mm]	L1 [mm]	L2 [mm]	e [mm]	e1 [mm]
25	20	IR	727 908 537	0.007	50	20	20	2.3	1.9
32	20	IR	727 908 542	0.010	50	20	20	2.9	1.9
32	25	IR	727 908 541	0.010	50	20	20	2.9	2.3
40	20	IR	727 908 548	0.016	58	20	23	3.7	1.9
40	25	IR	727 908 547	0.016	55	20	20	3.7	2.3
40	32	IR	727 908 546	0.018	55	20	20	3.7	2.9
50	25	IR	727 908 554	0.024	60	20	20	4.6	2.3
50	32	IR	727 908 553	0.027	60	20	20	4.6	2.9
50	40	IR	727 908 552	0.030	60	20	20	4.6	3.7
63	32	IR	727 908 560	0.043	65	20	20	5.8	2.9
63	40	IR	727 908 559	0.047	65	20	20	5.8	3.7
63	50	IR	727 908 558	0.051	65	20	20	5.8	4.6
75	40	IR	727 908 566	0.062	68	20	20	6.8	3.7
75	50	IR	727 908 565	0.071	65	20	20	6.8	4.6
75	63	IR	727 908 564	0.075	65	20	20	6.8	5.8
90	63	IR	727 908 571	0.115	75	22	19	8.2	5.8
90	75	IR	727 908 570	0.130	75	22	19	8.2	6.8
110	75	IR	727 908 577	0.215	90	28	18	10.0	6.8
110	90	IR	727 908 576	0.225	90	28	30	10.0	8.2
125	110	IR	727 908 580	0.335	100	32	30	11.4	10.0
140	110	IR	727 908 585	0.423	110	33	29	12.7	10.0
140	125	IR	727 908 584	0.462	110	34	30	12.7	11.4
160	110	IR	727 908 590	0.586	120	39	27	14.6	10.0
160	140	IR	727 908 588	0.647	120	40	35	14.6	12.7
180	90	IR	727 908 978	0.968	157	45	22	16.4	8.8
180	110	IR	727 908 977	0.987	157	45	28	16.4	10.0
180	125	IR	727 908 976	0.890	136	45	32	16.4	11.4
180	140	IR	727 908 975	0.917	136	45	35	16.4	12.7
180	160	IR	727 908 974	1.031	136	45	35	16.4	14.6
200	160	IR	727 908 592	1.149	145	50	40	18.2	14.6

table continued next page

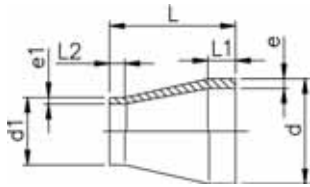

d [mm]	d1 [mm]	FM	Code	kg	L [mm]	L1 [mm]	L2 [mm]	e [mm]	e1 [mm]
200	180	IR	727 908 979	1.350	151	50	45	18.2	16.4
225	110	IR	727 908 595	1.485	160	55	35	20.5	10.0
225	160	IR	727 908 596	1.563	160	55	40	20.5	14.6
225	180	IR	727 908 983	1.893	171	55	45	20.5	16.4
225	200	IR	727 908 597	1.723	160	55	50	20.5	18.2
250	160	--	727 908 990	1.483	194	60	55	22.7	14.6
250	225	--	727 908 987	2.592	182	60	55	22.7	20.5
280	225	--	727 908 992	1.854	105	30	20	25.4	20.5
280	250	--	727 908 991	1.311	70	30	18	25.4	22.7
315	225	--	727 908 997	2.857	130	30	20	28.6	20.5
315	250	--	727 908 996	3.500	100	30	20	28.6	22.7
315	280	--	727 908 995	1.577	63	30	18	28.6	25.4
355	250	--	727 908 963	5.490	245	90	60	32.3	22.7
355	280	--	727 908 962	5.462	245	90	70	32.2	25.4
355	315	--	727 908 961	3.700	245	90	80	32.2	28.6
400	315	--	727 908 966	5.300	260	95	80	36.3	28.6
400	355	--	727 908 965	4.800	260	95	90	36.3	32.2
450	280	--	727 908 960	9.000	230	60	70	40.9	25.4
450	315	--	727 908 948	8.000	230	60	80	40.9	28.6
450	355	--	727 908 950	7.400	230	60	90	40.9	32.2
450	400	--	727 908 951	6.000	230	60	95	40.9	36.3
500	315	--	727 908 953	12.000	230	60	80	45.4	28.6
500	355	--	727 908 954	10.800	230	60	90	45.4	32.2
500	400	--	727 908 956	10.000	230	60	95	45.4	36.3
500	450	--	727 908 964	8.300	230	60	60	45.4	40.9

Reducing Bushes eccentric, PP-H SDR11

Model:

- Conventional butt fusion according to DVS2207
- Machined

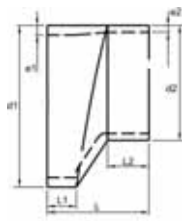

d1 [mm]	d2 [mm]	PN	Code	kg	L [mm]	L1 [mm]	L2 [mm]	e1 [mm]	e2 [mm]
63	50	10	700 647 700	1.000	120	35	35	5,8	4,6
75	50	10	700 647 701	1.000	120	40	35	6,8	4,6
75	63	10	700 647 702	1.000	120	40	35	6,8	5,8
90	63	10	700 647 703	0.253	140	50	50	8,2	5,8
90	75	10	700 647 704	1.000	140	50	50	8,2	6,8
110	75	10	700 647 705	0.378	140	50	50	10	6,8
110	90	10	700 647 706	1.000	140	50	50	10	8,2
125	90	10	700 647 707	1.000	140	50	50	11,4	5,1
125	110	10	700 647 708	1.000	140	50	50	11,4	10
140	90	10	700 647 709	1.000	140	50	50	12,7	8,2
140	110	10	700 647 710	1.000	140	50	50	12,7	10
160	90	10	700 647 711	1.000	140	50	54	14,6	8,2
160	110	10	700 647 712	1.000	120	40	45	14,6	10
160	125	10	700 647 713	1.000	110	40	44	14,6	11,4
160	140	10	700 647 714	1.000	90	40	33	14,6	12,7
180	125	10	700 647 715	1.000	130	40	52	16,4	11,4
180	140	10	700 647 716	1.000	110	40	41	16,4	12,7
180	160	10	700 647 717	1.000	90	40	33	16,4	16,4
200	140	10	700 647 718	1.000	140	40	50	18,2	12,7
200	160	10	700 647 719	1.000	120	40	41	18,2	14,6
200	180	10	700 647 720	1.000	100	40	43	18,2	16,4
225	160	10	700 647 721	1.000	140	40	57	20,5	14,6
225	180	10	700 647 722	1.000	120	40	48	20,5	16,4
225	200	10	700 647 723	1.000	100	40	40	20,5	18,2
250	180	10	700 647 724	1.000	150	40	54	22,7	16,4
250	200	10	700 647 725	1.000	130	40	55	22,7	18,2
250	225	10	700 647 726	1.000	110	40	40	22,7	20,5
280	200	10	700 647 727	1.000	160	40	58	25,4	18,2
280	225	10	700 647 728	1.000	130	40	52	25,4	20,5
280	250	10	700 647 729	1.000	110	40	47	25,4	22,7
315	225	10	700 647 730	1.000	160	40	62	28,6	20,5
315	250	10	700 647 731	1.000	140	40	57	28,6	22,7
315	280	10	700 647 732	1.000	120	40	54	28,6	25,4

table continued next page

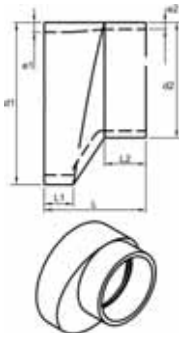

d1 [mm]	d2 [mm]	PN	Code	kg	L [mm]	L1 [mm]	L2 [mm]	e1 [mm]	e2 [mm]
355	250	10	700 647 733	1.000	180	40	74	32,2	22,7
355	280	10	700 647 734	1.000	150	40	61	32,2	25,4
355	315	10	700 647 735	1.000	120	40	51	32,2	28,6
400	280	10	700 647 736	1.000	200	40	85	36,3	25,4
400	315	10	700 647 737	4.793	170	40	75	36,3	28,6
400	355	10	700 647 738	1.000	130	40	58	36,3	32,2
450	315	10	700 647 739	1.000	210	40	86	40,9	28,6
450	355	10	700 647 740	1.000	180	40	79	40,9	32,2
450	400	10	700 647 741	1.000	140	40	65	40,9	36,3
500	315	10	700 647 742	12.810	260	40	107	45,4	28,6
500	355	10	700 647 743	8.550	220	40	91	45,4	32,2
500	400	10	700 647 744	10.063	190	40	86	45,4	36,3
500	450	10	700 647 745	1.000	140	40	65	45,4	40,9
560	450	10	700 647 746	1.000	200	40	91	50,8	40,9
560	500	10	700 647 747	1.000	150	40	70	50,8	45,4
630	500	10	700 647 748	1.000	220	40	99	57,2	45,4
630	560	10	700 647 749	1.000	170	40	84	57,2	50,8

Reducing Bushes eccentric, PP-H SDR17.6

Model:

- Conventional butt fusion according to DVS2207
- Machined

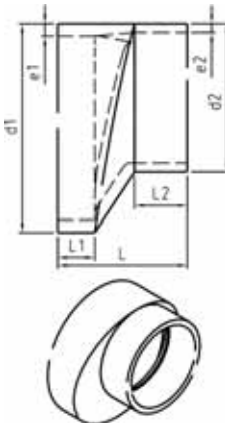

d1 [mm]	d2 [mm]	PN	Code	kg	L [mm]	L1 [mm]	L2 [mm]	e1 [mm]	e2 [mm]
63	50	6	700 647 750	1.000	120	35	35	3,6	2,9
75	50	6	700 647 751	1.000	120	40	35	4,3	2,9
75	63	6	700 647 752	1.000	120	40	35	4,3	3,6
90	63	6	700 647 753	1.000	140	50	50	5,1	3,6
90	75	6	700 647 754	1.000	140	50	50	5,1	4,3
110	75	6	700 647 755	0.300	140	50	50	6,3	4,3
110	90	6	700 647 756	1.000	140	50	50	6,3	5,1
125	90	6	700 647 757	1.000	140	50	50	7,1	5,1
125	110	6	700 647 758	1.000	140	50	50	7,1	6,3
140	90	6	700 647 759	1.000	140	50	50	8,0	5,1
140	110	6	700 647 760	1.000	140	50	50	8,0	6,3
160	90	6	700 647 761	1.000	140	50	54	9,5	5,4
160	90	6	700 647 762	1.000	120	40	45	9,5	6,6
160	125	6	700 647 763	1.000	110	40	44	9,5	7,4
160	140	6	700 647 764	1.000	90	40	33	9,5	8,3
180	125	6	700 647 765	1.000	130	40	52	10,7	7,4
180	140	6	700 647 766	1.000	110	40	41	10,7	8,3
180	160	6	700 647 767	1.000	90	40	33	10,7	9,5
200	140	6	700 647 768	1.000	140	40	50	11,9	8,3
200	160	6	700 647 769	1.000	120	40	41	11,9	9,5
200	180	6	700 647 770	1.000	100	40	43	11,9	10,7
225	160	6	700 647 771	1.000	140	40	57	13,4	9,5
225	180	6	700 647 772	1.000	120	40	48	13,4	10,7
225	200	6	700 647 773	1.000	100	40	40	13,4	11,9
250	180	6	700 647 774	1.000	150	40	54	14,8	10,7
250	200	6	700 647 775	1.000	130	40	55	14,8	11,9
250	225	6	700 647 776	1.000	110	40	40	14,8	13,4
280	200	6	700 647 777	1.000	160	40	58	16,6	11,9
280	225	6	700 647 778	1.000	130	40	52	16,6	13,4
280	250	6	700 647 779	1.000	110	40	47	16,6	14,8
315	225	6	700 647 780	1.000	160	40	62	18,7	13,4
315	250	6	700 647 781	1.000	140	40	57	18,7	14,8
315	280	6	700 647 782	1.000	120	40	54	18,7	16,6
355	250	6	700 647 783	1.000	180	40	74	21,1	14,8
355	280	6	700 647 784	1.000	150	40	61	21,1	16,6
355	315	6	700 647 785	1.000	120	40	51	21,1	18,7
400	280	6	700 647 786	1.000	200	40	85	23,7	16,6
400	315	6	700 647 787	1.000	170	40	75	23,7	18,7
400	355	6	700 647 788	1.000	130	40	58	23,7	21,1
450	315	6	700 647 789	1.000	210	40	86	26,7	18,7

table continued next page

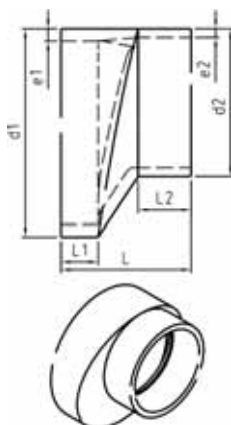

d1 [mm]	d2 [mm]	PN	Code	kg	L [mm]	L1 [mm]	L2 [mm]	e1 [mm]	e2 [mm]
450	355	6	700 647 790	1.000	180	40	79	26,7	21,1
450	400	6	700 647 791	1.000	140	40	65	26,7	23,7
500	315	6	700 647 792	1.000	260	40	107	29,7	18,7
500	355	6	700 647 793	1.000	220	40	91	29,7	21,1
500	400	6	700 647 794	1.000	190	40	86	29,7	23,7
500	450	6	700 647 795	1.000	140	40	65	29,7	26,7
560	450	6	700 647 796	1.000	200	40	91	33,2	26,7
560	500	6	700 647 797	1.000	150	40	70	33,2	29,7
630	500	6	700 647 798	1.000	220	40	99	37,4	29,7
630	560	6	700 647 799	1.000	170	40	84	37,4	33,2

27 90 89

PROGEF Standard reducer S8.3/SDR17.6

Model:

- Material: PP-H
- Conventional butt-welding according to DVS 2207 part 11
- IR = Infrared-(IR Plus®) compatible. Choose fusion parameters: PP-H

¹ Material: PP-R

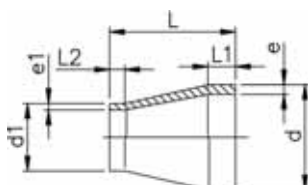

d [mm]	d1 [mm]	FM	Code	kg	L [mm]	L1 [mm]	L2 [mm]	e [mm]	e1 [mm]
50	40	IR	727 908 949	0.010	55	12	12	2,9	2,3
63	40	IR	727 908 901	0.020	65	16	12	3,6	2,3
63	50	IR	727 908 900	0.020	65	16	12	3,6	2,9
75	40	IR	727 908 904	0.041	65	20	20	4,3	2,3
75	50	IR	727 908 465	0.047	65	20	20	4,8	3,2
75	63	IR	727 908 464	0.053	65	20	20	4,3	3,6
90	63	IR	727 908 471	0.079	75	22	19	5,1	3,6
90	75	IR	727 908 470	0.090	75	21	19	5,1	4,3
110	75	IR	727 908 477	0.144	90	28	18	6,3	4,3
110	90	IR	727 908 476	0.158	90	28	20	6,3	5,1
125	110	IR	727 908 912	0.190	108	32	28	7,1	6,3
140	110	IR	727 908 917	0.322	115	35	28	8,0	6,3
140	125	IR	727 908 916	0.353	115	35	32	8,0	7,1
160	110	IR	727 908 922	0.454	124	40	28	9,1	6,3
160	140	IR	727 908 920	0.482	124	40	35	9,1	8,0
180	90	IR	727 908 928	0.866	157	45	22	10,2	5,1
180	110	IR	727 908 927	0.698	157	45	28	10,2	6,3
180	125	IR	727 908 926	0.596	136	45	32	10,2	7,1
180	140	IR	727 908 925	0.632	136	45	35	10,2	8,0
180	160	IR	727 908 924	0.677	136	45	40	10,2	9,1
200	160	IR	727 908 930	0.805	151	50	40	11,4	9,1
200	180	IR	727 908 929	0.895	151	50	45	11,4	10,2
225	110	IR	727 908 936	1.001	171	55	40	12,8	6,3
225	160	IR	727 908 934	1.082	171	55	45	12,8	9,1
225	180	IR	727 908 933	1.337	171	55	45	12,8	10,2
225	200	IR	727 908 932	1.184	184	60	40	12,8	11,4
250	160	--	727 908 940	2.062	194	60	40	14,2	9,1
250	225	--	727 908 937	1.792	182	60	55	14,2	12,8
1 280	225	--	727 908 942	1.365	105	30	20	15,9	12,8
1 280	250	--	727 908 941	0.858	70	30	18	15,9	14,2
1 315	225	--	727 908 947	2.062	130	30	20	17,9	12,8
1 315	250	--	727 908 946	1.578	100	30	20	17,9	14,2
1 315	280	--	727 908 945	1.156	63	30	18	17,9	15,9
1 355	250	--	727 908 959	3.000	245	90	60	20,1	14,2
1 355	280	--	727 908 958	2.700	245	90	70	20,1	15,9
1 355	315	--	727 908 957	2.400	245	90	80	20,1	17,9
1 400	315	--	727 908 972	3.600	260	95	80	22,7	17,9
1 400	355	--	727 908 971	3.100	260	95	90	22,7	20,1
450	280	--	727 908 967	6.000	230	60	70	25,5	15,9
450	315	--	727 908 984	5.400	230	60	80	25,5	17,9
450	355	--	727 908 988	5.000	230	60	90	25,5	20,1
450	400	--	727 908 989	5.000	230	60	95	25,5	22,7
500	315	--	727 908 993	8.100	230	60	80	28,4	17,9

table continued next page

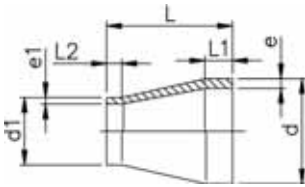

d [mm]	d1 [mm]	FM	Code	kg	L [mm]	L1 [mm]	L2 [mm]	e [mm]	e1 [mm]
500	355	--	727 908 994	7.300	230	60	95	28,4	20,1
500	400	--	727 908 998	6.700	230	60	95	28,4	22,7
500	450	--	727 908 999	5.500	230	60	60	28,4	25,5

27 96 89

PROGEF Standard end cap S5/SDR11

Model:

- Material: PP-H
- Conventional butt-welding according to DVS 2207 part 11
- IR = Infrared-(IR Plus®) compatible. Choose fusion parameters: PP-H

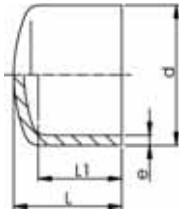

d [mm]	FM	Code	kg	L [mm]	L1 [mm]	e [mm]
20	IR	727 968 931	0.005	42	30	1.9
25	IR	727 968 932	0.005	50	35	2.3
32	IR	727 968 933	0.013	55	40	2.9
40	IR	727 968 934	0.018	65	45	3.7
50	IR	727 968 935	0.043	70	50	4.6
63	IR	727 968 936	0.080	80	55	5.8
75	IR	727 968 937	0.126	90	60	6.8
90	IR	727 968 938	0.107	105	70	8.2
110	IR	727 968 939	0.384	120	80	10.0
125	IR	727 968 940	0.237	50	25	11.4
140	IR	727 968 941	0.350	60	30	12.7
160	IR	727 968 942	0.684	76	40	14.6
180	IR	727 968 943	1.103	125	88	16.4
200	IR	727 968 944	1.089	100	50	18.2
225	IR	727 968 945	1.531	103	60	20.5

27 96 89

PROGEF Standard end cap S5/SDR11

Model:

- Material: PP-R
- Machined
- Conventional butt-welding according to DVS 2207 part 11



d [mm]	Code	kg	L [mm]	e [mm]
250	727 968 846	1.900	60	22,7
280	727 968 847	2.600	65	25,4
315	727 968 848	3.600	70	28,6
355	727 968 849	5.100	80	32,2
400	727 968 850	7.200	85	36,3
450	727 968 851	10.200	95	40,9
500	727 968 852	14.000	105	74,5

27 96 89

PROGEF Standard end cap S8.3/SDR17.6

Model:

- Material: PP-H
- Conventional butt-welding according to DVS 2207 part 11
- IR = Infrared-(IR Plus®) compatible. Choose fusion parameters: PP-H

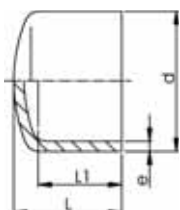

d [mm]	FM	Code	kg	L [mm]	L1 [mm]	e [mm]
50	IR	727 968 910	0.054	75	53	2,9
63	IR	727 968 911	0.056	85	58	3,6
75	IR	727 968 912	0.045	90	60	4,3
90	IR	727 968 913	0.145	105	70	5,1
110	IR	727 968 914	0.262	120	80	6,3
125	IR	727 968 915	0.161	50	25	7,1
140	IR	727 968 916	0.251	60	30	8,0
160	IR	727 968 917	0.401	76	40	9,1

table continued next page

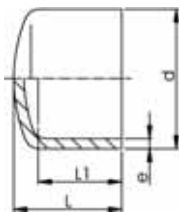

d [mm]	FM	Code	kg	L [mm]	L1 [mm]	e [mm]
180	IR	727 968 918	0.769	125	88	10,2
200	IR	727 968 919	0.751	100	50	11,4
225	IR	727 968 920	1.060	103	60	12,8

27 96 89

PROGEF Standard end cap S8.3/SDR17.6

Model:

- Material: PP-R
- Conventional butt-welding according to DVS 2207 part 11
- Machined



d [mm]	Code	kg	L [mm]	e [mm]
250	727 968 821	1.600	55	14,2
280	727 968 822	2.100	60	15,9
315	727 968 823	3.000	65	17,9
355	727 968 824	4.200	70	20,1
400	727 968 825	6.000	75	22,7
450	727 968 826	8.600	85	25,5
500	727 968 827	11.600	90	28,3



Adaptor fittings for butt fusion

27 91 02

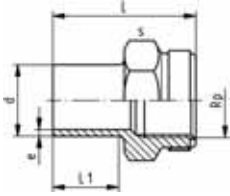

PROGEF Standard adaptor socket metric Rp

Model:

- Material: PP-H
- With butt fusion spigot **SDR11** and BSP parallel female thread Rp, reinforced
- Reinforcing ring stainless (A2)
- Connection to plastic or metal threads
- Do not use thread sealing pastes that are harmful to PP
- Install with low mechanical stress and avoid large cyclic temperature changes

d [mm]	Rp [inch]	PN	FM	Code	kg	L [mm]	L1 [mm]	s [mm]	e [mm]
20	½	10	IR	727 910 266	0.017	49	23	32	1,9
25	¾	10	IR	727 910 267	0.022	50	23	36	2,3
32	1	10	IR	727 910 268	0.038	54	23	46	2,9
40	1 ¼	10	IR	727 910 269	0.066	56	23	55	3,7
50	1 ½	10	IR	727 910 270	0.090	60	23	65	4,6
63	2	10	IR	727 910 271	0.123	62	23	80	5,8

27 91 43

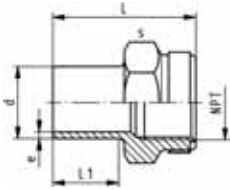

PROGEF Standard adaptor socket metric NPT

Model:

- Material: PP-H
- With butt fusion spigot **SDR11** and NPT tapered female thread, reinforced
- Reinforcing ring stainless (A2)
- Connection to plastic or metal threads
- Do not use thread sealing pastes that are harmful to PP
- Install with low mechanical stress and avoid large cyclic temperature changes

d [mm]	NPT [inch]	PN	FM	Code	kg	L [mm]	L1 [mm]	s [mm]	e [mm]
20	½	10	IR	727 914 356	0.017	49	23	32	1,9
25	¾	10	IR	727 914 357	0.022	51	23	36	2,3
32	1	10	IR	727 914 358	0.039	54	23	46	2,9
40	1 ¼	10	IR	727 914 359	0.057	56	23	55	3,7
50	1 ½	10	IR	727 914 360	0.085	60	23	65	4,6
63	2	10	IR	727 914 361	0.122	62	23	80	5,8

27 91 05

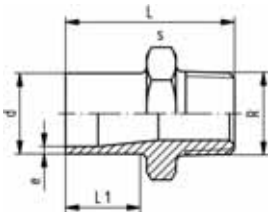

PROGEF Standard adaptor nipple metric R

Model:

- Material: PP-H
- With butt fusion spigot and BSP tapered male thread
- Do not use thread sealing pastes that are harmful to PP
- Install with low mechanical stress and avoid large cyclic temperature changes

d [mm]	R [inch]	PN	FM	Code	kg	L [mm]	L1 [mm]	s [mm]	e [mm]
20	½	10	IR	727 910 556	0.013	51	23	32	1,9
25	¾	10	IR	727 910 557	0.014	52	23	36	2,3
32	1	10	IR	727 910 558	0.027	55	23	46	2,9
40	1 ¼	10	IR	727 910 559	0.041	58	23	55	3,7
50	1 ½	10	IR	727 910 560	0.062	60	23	65	4,6
63	2	10	IR	727 910 561	0.096	67	26	80	5,8

27 91 46

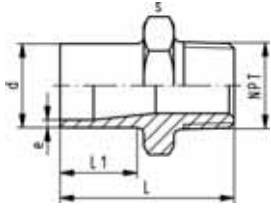

PROGEF Standard adaptor nipple metric NPT

Model:

- Material: PP-H
- With butt fusion spigot **SDR11** and NPT tapered male thread
- Do not use thread sealing pastes that are harmful to PP
- Install with low mechanical stress and avoid large cyclic temperature changes

d [mm]	NPT [inch]	PN	FM	Code	kg	L [mm]	L1 [mm]	s [mm]	e [mm]
20	½	10	IR	727 914 656	0.013	51	23	32	1.9
25	¾	10	IR	727 914 657	0.026	52	23	36	2.3
32	1	10	IR	727 914 658	0.026	55	23	46	2.9
40	1 ¼	10	IR	727 914 659	0.041	58	24	55	3.7
50	1 ½	10	IR	727 914 660	0.062	60	23	65	4.6
63	2	10	IR	727 914 661	0.097	67	26	80	5.8

27 96 86

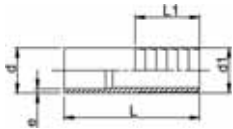

PROGEF Standard hose connector metric

Model:

- Material: PP-H
- With butt fusion spigot **SDR11** and parallel hose connection

d [mm]	d1 [mm]	PN	FM	Code	kg	L [mm]	L1 [mm]	e [mm]
20	20	10	IR	727 968 606	0.007	64	27	1.9
25	25	10	IR	727 968 607	0.014	75	36	2.3
32	32	10	IR	727 968 608	0.022	82	36	2.9
40	40	10	IR	727 968 609	0.032	84	42	3.7
50	50	10	IR	727 968 610	0.053	90	48	4.6
63	60	10	IR	727 968 611	0.088	100	50	5.8

End Cap PP-H, SDR11 with female thread

Model:

- Conventional butt fusion according to DVS2207
- Machined
- metric - Rp
- other thread-dimensions and NPT-thread available on request

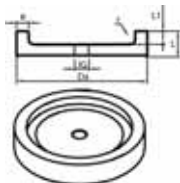

d [mm]	Rp [inch]	PN	Code	kg	L [mm]	L1 [mm]	e [mm]	r [mm]
63	½	10	700 647 924	1.000	35	10	5,8	5
75	½	10	700 647 925	1.000	35	10	6,8	5
90	½	10	700 647 926	1.000	35	10	8,2	5
110	½	10	700 647 927	1.000	35	10	10	5
125	½	10	700 647 928	1.000	36	10	11,4	5
140	½	10	700 647 929	1.000	38	10	12,7	5
160	½	10	700 647 930	1.000	40	10	14,6	6
180	½	10	700 647 931	1.000	41	10	16,4	6
200	½	10	700 647 932	1.000	45	11	18,2	6
225	½	10	700 647 933	1.000	52	12	20,5	10
250	½	10	700 647 934	1.000	57	14	22,7	11
280	½	10	700 647 935	1.000	63	15	25,4	13
315	½	10	700 647 936	1.000	72	17	28,6	14
355	½	10	700 647 937	1.000	80	19	32,2	16
400	½	10	700 647 938	1.000	90	22	36,3	18
450	½	10	700 647 939	1.000	102	25	40,9	20
500	½	10	700 647 940	1.000	113	27	45,4	23
560	½	10	700 647 941	1.000	127	30	50,8	25
630	½	10	700 647 942	1.000	143	34	57,2	29



End Cap PP-H, SDR17.6 with female thread

Model:

- Conventional butt fusion according to DVS2207
- Machined
- metric - Rp
- other thread-dimensions and NPT-thread available on request

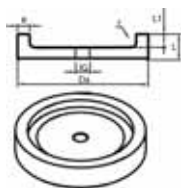

d [mm]	Rp [inch]	PN	Code	kg	L [mm]	L1 [mm]	e [mm]	r [mm]
63	½	6	700 665 127	1.000	35	10	3,6	5
75	½	6	700 665 128	1.000	35	10	4,3	5
90	½	6	700 665 129	1.000	35	10	5,1	5
110	½	6	700 665 130	1.000	35	10	6,3	5
125	½	6	700 665 131	1.000	35	10	7,1	5
140	½	6	700 665 132	1.000	35	10	8,0	5
160	½	6	700 665 133	1.000	35	10	9,1	6
180	½	6	700 665 134	1.000	35	10	10,2	6
200	½	6	700 665 135	1.000	35	10	11,4	6
225	½	6	700 665 136	1.000	35	10	12,8	8
250	½	6	700 665 137	1.000	35	10	14,2	8
280	½	6	700 665 138	1.000	40	10	15,9	8
315	½	6	700 665 139	1.000	45	11	17,9	8
355	½	6	700 665 140	1.000	50	12	20,1	8
400	½	6	700 665 141	1.000	57	14	22,7	10
450	½	6	700 665 142	1.000	67	16	26,7	10
500	½	6	700 665 143	1.000	75	18	29,7	10
560	½	6	700 665 144	1.000	83	20	33,2	10
630	½	6	700 665 145	1.000	93	22	37,2	10

Instrument Installation Fittings PP-H, SDR11 with female thread

Model:

- Conventional butt fusion according to DVS2207
- Machined
- metric - Rp
- other thread-dimensions and NPT-thread available on request

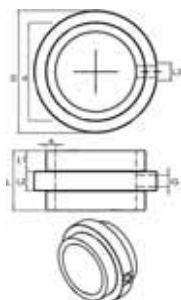

d [mm]	Rp [inch]	PN	Code	kg	L [mm]	L1 [mm]	L2 [mm]	D [mm]	e [mm]
63	½	10	700 665 351	1.000	90	30	30	90	5,8
75	½	10	700 665 352	1.000	90	30	30	110	6,8
90	½	10	700 665 353	1.000	100	30	40	125	8,2
110	½	10	700 665 354	1.000	100	30	40	140	10
125	½	10	700 665 355	1.000	110	35	40	160	11,4
140	½	10	700 665 356	1.000	125	40	45	180	12,7
160	½	10	700 665 357	1.000	125	40	45	200	14,6
180	½	10	700 665 358	1.000	135	45	45	225	16,4
200	½	10	700 665 359	1.000	135	45	45	250	18,2
225	½	10	700 665 360	1.000	135	45	45	280	20,5
250	½	10	700 665 361	1.000	145	50	45	280	22,7
280	½	10	700 665 362	1.000	155	50	55	315	25,4
315	½	10	700 665 363	1.000	155	50	55	355	28,6
355	½	10	700 665 364	1.000	115	30	55	400	32,2
400	½	10	700 665 365	1.000	130	30	70	450	36,3

Instrument Installation Fittings PP-H, SDR17.6 with female thread



Model:

- Conventional butt fusion according to DVS2207
- Machined
- metric - Rp
- other thread-dimensions and NPT-thread available on request

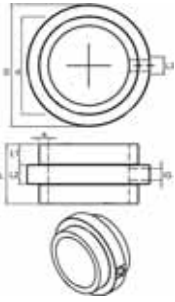

d [mm]	Rp [inch]	PN	Code	kg	L [mm]	L1 [mm]	L2 [mm]	D [mm]	e [mm]
63	½	6	700 665 388	1.000	90	30	30	90	3,6
75	½	6	700 665 389	1.000	90	30	30	110	4,3
90	½	6	700 665 390	1.000	100	30	40	125	5,1
110	½	6	700 665 391	1.000	100	30	40	140	6,3
125	½	6	700 665 392	1.000	110	35	40	160	7,1
140	½	6	700 665 393	1.000	125	40	45	180	8,0
160	½	6	700 665 394	1.000	125	40	45	200	9,1
180	½	6	700 665 395	1.000	135	45	45	225	10,2
200	½	6	700 665 396	1.000	135	45	45	250	11,4
225	½	6	700 665 397	1.000	135	45	45	280	12,8
250	½	6	700 665 398	1.000	145	50	45	280	14,2
280	½	6	700 665 399	1.000	155	50	55	315	15,9
315	½	6	700 665 400	1.000	155	50	55	355	17,9
355	½	6	700 665 401	1.000	115	30	55	400	20,1
400	½	6	700 665 402	1.000	130	30	70	450	22,7

27 31 10

SIGNET Sensor installation fittings

PROGEF Standard installation fitting type 311

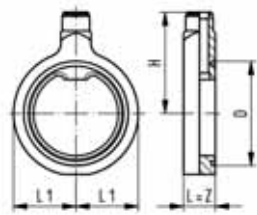

Model:

- Material: PP-H
- Threaded outlet 1 ¼" NPSM
- Suitable for backing flanges metric and inch
- Suitable for SDR 11 - SDR 17.6
- Delivered with profile O-ring

Range of use:

- compatible signet flow sensors: type 2551, 2537, 515, 8510, 2536, 8512

Attention:

- sensor length depends on installation fitting

d [mm]	DN [mm]	d [inch]	PN	EPDM Code	FPM Code	kg
75	65	2 ½	16	727 311 012	727 311 042	0.460
90	80	3	16	727 311 013	727 311 043	0.542
110	100	4	16	727 311 014	727 311 044	0.668
125	100	4	16	727 311 015	727 311 045	0.595
140	125	5	16	727 311 016	727 311 046	0.842
160	150	6	16	727 311 017	727 311 047	1.023
180	150	6	16	727 311 018	727 311 048	0.868
200	200	8	16	727 311 019	727 311 049	1.578
225	200	8	16	727 311 020	727 311 050	1.332
250	250	10	16	727 311 021	727 311 051	2.209
280	250	10	16	727 311 022	727 311 052	1.836
315	300	12	16	727 311 023	727 311 053	2.495

d [mm]	D [mm]	H [mm]	L [mm]	L1 [mm]	Sensor Type
75	88	133	48	61	flow X1
90	102	140	48	69	flow X1
110	132	149	48	79	flow X1
125	132	144	48	79	flow X1
140	157	149	48	94	flow X1
160	182	156	48	106	flow X1
180	182	163	48	106	flow X1
200	236	170	48	134	flow X1
225	236	178	48	134	flow X1
250	289	263	48	160	flow X2
280	289	273	48	160	flow X2
315	329	285	48	185	flow X2

PROGEF Standard installation fitting type 312 metric



Model:

- Material: PP-H
- Threaded outlet 1 1/4" NPSM
- Top saddle with EPDM gasket
- Stainless steel bolts and nuts

Range of use:

- compatible signet flow sensors: type 2551, 2537, 515, 8510, 2536, 8512

Attention:

- sensor length depends on installation fitting
- working temperature max. +40°C (water)

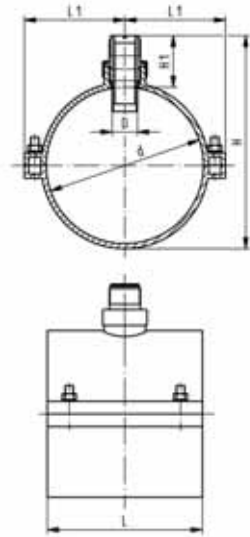

d [mm]	DN [mm]	PN	Code	kg	D [mm]	L [mm]	L1 [mm]	H [mm]	H1 [mm]	Sensor Type
75	65	8	727 312 072	0.488	34	78	62	172	88	flow X1
90	80	8	727 312 073	0.514	34	86	69	186	87	flow X1
110	100	8	727 312 074	0.602	34	98	79	206	86	flow X1
125	100	8	727 312 075	0.667	34	101	85	212	78	flow X1
140	125	6	727 312 076	0.949	34	114	104	227	75	flow X1
160	150	6	727 312 077	0.985	34	114	114	243	72	flow X1
180	150	6	727 312 078	2.118	34	168	134	348	144	flow X2
200	200	6	727 312 079	2.045	34	168	132	357	142	flow X2
225	200	5	727 312 080	2.211	34	174	146	375	136	flow X2
250	250	5	727 312 081	2.616	34	179	159	397	131	flow X2
280	250	5	727 312 082	3.583	34	179	167	426	127	flow X2
315	300	5	727 312 083	4.311	34	248	202	450	120	flow X2

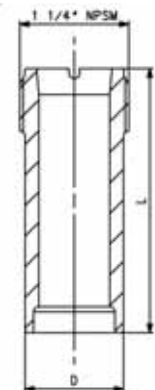

PROGEF Standard installation fitting type 314

Model:

- Material: PP-H
- Threaded outlet 1 1/4" NPSM
- for conventional hot gas back welding according to DVS 2207 part 3

Range of use:

- compatible signet flow sensors: type 2551, 2537, 515, 8510, 2536, 8512
- compatible signet pH/ORP sensors: type 2724, 2725, 2726

Attention:

- only for pressureless or low pressure application
- pressure rate depends on quality of hot gas back welding
- please consult the instruction manual
- Installation by trained and certified welders only
- sensor length depends on installation fitting

d [mm]	DN	PN* [bar]	Code	kg	D [mm]	L [mm]	Sensor Type
75 - 180	65 - 150	-	727 314 000	0.050	37.5	68	flow X0, pH XX
200 - 355	200 - 350	-	727 314 001	0.057	37.5	102	flow X1
400 - 630	350 - 600	-	727 314 002	0.885	37.5	178	flow X2

27 31 80

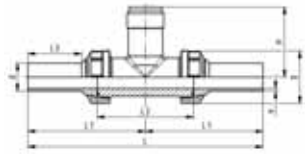

PROGEF Standard installation fitting type 318 S5/SDR11 for butt fusion systems metric

Model:

- Material: PP-H
- Threaded outlet 1 ¼" NPSM
- Union end with butt fusion spigot PP-H

Range of use:

- compatible signet flow sensors: type 2551, 2537, 515, 8510, 2536, 8512
- compatible signet pH/ORP sensors: type 2724, 2725, 2726

Attention:

- sensor length depends on installation fitting

d [mm]	DN [mm]	PN	FM	EPDM Code	FPM Code	kg	
20	15	10	IR	727 318 006	727 318 036	0.136	
25	20	10	IR	727 318 007	727 318 037	0.208	
32	25	10	IR	727 318 008	727 318 038	0.250	
40	32	10	IR	727 318 009	727 318 039	0.356	
50	40	10	IR	727 318 010	727 318 040	0.510	
63	50	10	IR	727 318 011	727 318 041	0.800	

d [mm]	e [mm]	D [mm]	L [mm]	L1 [mm]	L2 [mm]	L3 [mm]	H [mm]	Sensor Type	
20	1.9	48	224	112	90	52	76	flow X0, pH XX	
25	2.3	58	242	121	100	53	78	flow X0, pH XX	
32	2.9	65	256	128	110	55	81	flow X0, pH XX	
40	3.7	79	272	136	110	60	85	flow X0, pH XX	
50	4.6	91	294	147	120	66	89	flow X0, pH XX	
63	5.8	105	316	158	130	70	95	flow X0, pH XX	

Unions for butt fusion

EPDM 27 51 85
FPM 27 52 85

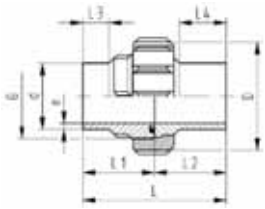

PROGEF Standard union S5/SDR11

Model:

- Material: PP-H
- With butt fusion ends
- Conventional butt fusion and (IR Plus®) compatible
- Gasket: O-Ring EPDM No. 48 41 00
- **For the dimensions d75-110 please see instructions for the installation**

d [mm]	PN	FM	EPDM Code	FPM Code	kg
20	10	IR	727 518 506	727 528 506	0.047
25	10	IR	727 518 507	727 528 507	0.072
32	10	IR	727 518 508	727 528 508	0.100
40	10	IR	727 518 509	727 528 509	0.145
50	10	IR	727 518 510	727 528 510	0.190
63	10	IR	727 518 511	727 528 511	0.332
75	10	IR	727 518 512	727 528 512	0.520
90	10	IR	727 518 513	727 528 513	0.539
110	10	IR	727 518 514	727 528 514	0.758

d [mm]	D [mm]	G [inch]	L [mm]	L1 [mm]	L2 [mm]	L3 [mm]	L4 [mm]	e [mm]
20	48	1	107	54.0	53.0	13	26	1.9
25	58	1 1/4	113	57.0	56.0	12	26	2.3
32	65	1 1/2	119	60.0	59.0	14	26	2.9
40	79	2	126	63.0	63.0	16	26	3.7
50	91	2 1/4	131	65.5	65.5	19	26	4.6
63	111	2 3/4	137	69.0	68.0	20	26	5.8
75	135	S107,5x3,6	131	66.0	65.5	22	24	6.8
90	135	S107,5x3,6	131	65.5	65.5	22	24	8.2
110	158	S127,5x3,6	131	65.5	65.5	22	25	10.0

EPDM 27 51 84
FPM 27 52 84

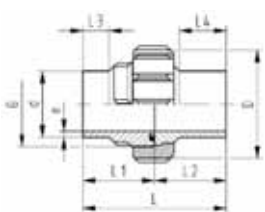

PROGEF Standard union S8.3/SDR17.6

Model:

- Material: PP-H
- With butt fusion ends
- IR = Infrared-(IR Plus®) compatible. Choose fusion parameters: PP-H
- Conventional butt-welding according to DVS 2207 part 11
- Jointing face: With O-ring groove
- **For the dimensions d75-110 please see instructions for the installation**

d [mm]	PN	FM	EPDM Code	FPM Code	kg
75	6	IR	727 518 412	727 528 412	0.476
90	6	IR	727 518 413	727 528 413	0.483
110	6	IR	727 518 414	727 528 414	0.664

d [mm]	D [mm]	G [inch]	L [mm]	L1 [mm]	L2 [mm]	e [mm]
75	135	S107,5x3,6	132	66.0	66.0	4,3
90	135	S107,5x3,6	131	65.5	65.5	5,1
110	158	S127,5x3,6	131	65.5	65.5	6,3

Instructions for the installation of unions in PP, PE d 75, d 90 and d 110

The newest generation of plastic unions in the above materials and dimensions has been fitted with a state-of-the-art, plastics-oriented buttress thread. You therefore have a product in which the nominal pressure and the safety reserve have been dramatically increased. Also new are the butt fusion versions. In this connection, there are a few points which you must be aware of.

Caution

- ① The threads of the union nut and bush have been reworked for PP, PVDF and PE! When using individual parts, please check prior to installation if the threads of the union bush and the union nut coincide.



Union bush with trapezoid thread on union nut with trapezoid thread
or
Union bush with buttress thread on union nut with buttress thread

Tip

To make installation of the union easier, wet the union nut.

- ② For the dimensions d90 and d110 we advise fusing the complete union, if possible (or slide the union nut to the collar of the union end) because after fusion the union nut cannot be slid over the fusion bead. (Fig. 1)
- ③ For design reasons, it is theoretically possible to combine different nominal diameters of union ends and nuts. To make sure combinations are technically correct, you can find the code numbers of the single parts and spare parts for each union in the Tables 1-3.

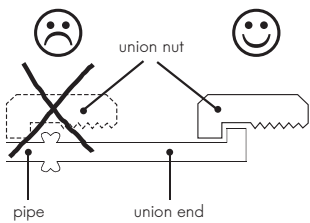

Fig. 1

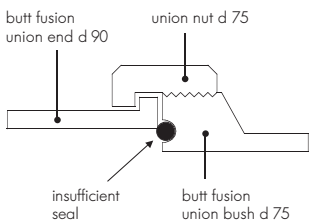

Fig. 2

Caution

Only use union bushes and union ends with the same nominal diameter!

A butt fusion union bush d75 may not be combined with a butt fusion union end d90 to form a reducer because this can cause leakage, as illustrated to the left. (Fig. 2)

Markings on the union nuts

SF/MS = socket fusion, BF/ST = butt fusion

SF/MS 75 specified for socket fusion d75
BF/ST 75-90 specified for butt fusion d75-75 and d90-90

SF/MS 90 specified socket fusion d90
BF/ST 110 specified butt fusion d110

110 specified for socket fusion d110

Tip

We recommend changing materials only for the union end for installation reasons.

Selection tables for single parts and spare parts



Butt fusion

Socket fusion

Table 1

Single parts for **PP-H** unions d 75, d 90 and d 110

d	BF/ST	SF/MS	SDR	PN	Code union end	Code union bush	Code union nut*
75			11	10	727 608 512	727 648 512	727 690 422
			17.6	6	727 608 412	727 648 412	727 690 422
			—	10	727 600 112	727 640 172	727 690 422
90			11	10	727 608 513	727 648 513	727 690 422
			17.6	6	727 608 413	727 648 413	727 690 422
			—	10	727 600 113	727 640 173	727 690 423
110			11	10	727 608 514	727 648 514	727 690 423
			17.6	6	727 608 414	727 648 414	727 690 423
			—	10	727 600 114	727 640 174	727 690 424

Table 2

Single parts for **PE 100** unions d 75, d 90 and d 110

d	BF/ST	SF/MS	SDR	PN	Code union end	Code union bush	Code union nut*
75			11	10	753 608 612	753 648 612	727 690 442
			17.6	10	753 608 412	753 648 412	727 690 442
90			11	10	753 608 613	753 648 613	727 690 442
			17.6	10	753 608 413	753 648 413	727 690 442
110			11	10	753 608 614	753 648 614	727 690 443
			17.6	10	753 608 414	753 648 414	727 690 443

Table 3

O-Rings for PP-H, PE 100

d	BF/ST	SF/MS	SDR	PN	Code O-Ring EPDM ¹	Code O-Ring FPM ¹
75				16	748 410 013	749 410 013
				16	748 410 014	749 410 014
90				16	748 410 014	749 410 014
				16	748 410 015	749 410 015
110				16	748 410 015	749 410 015
				16	748 410 016	749 410 016

* Union nuts overlap several dimensions

¹ Flange adaptor O-rings, one size smaller in nominal dimensions, are used for the d 75–110 butt-fusion unions

27 60 85

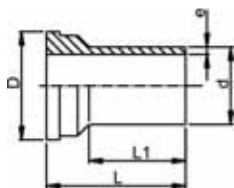

PROGEF Standard union end IR plus SDR11

Model:

- Material: PP-H
- Conventional butt-welding according to DVS 2207 part 11
- IR = Infrared-(IR Plus®) compatible. Choose fusion parameters: PP-H
- For the dimensions d75-110 please see instructions for the installation

d [mm]	PN	FM	Code	kg	D [mm]	L [mm]	L1 [mm]	e [mm]
20	10	IR	727 508 506	0.009	30	54	38	1.9
25	10	IR	727 508 507	0.017	39	57	42	2.3
32	10	IR	727 508 508	0.026	45	60	41	2.9
40	10	IR	727 508 509	0.043	57	63	42	3.7
50	10	IR	727 508 510	0.058	63	66	44	4.6
63	10	IR	727 508 511	0.095	78	69	45	5.8
75	10	IR	727 508 512	0.146	101	66	34	6.8
90	10	IR	727 508 513	0.158	101	66	45	8.2
110	10	IR	727 508 514	0.233	121	66	40	10.0

27 60 84

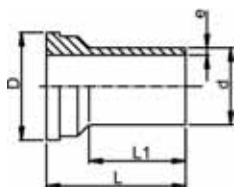

PROGEF Standard union end IR plus SDR17.6

Model:

- Material: PP-H
- Conventional butt-welding according to DVS 2207 part 11
- IR = Infrared-(IR Plus®) compatible. Choose fusion parameters: PP-H
- For the dimensions d75-110 please see instructions for the installation

d [mm]	PN	FM	Code	kg	D [mm]	L [mm]	L1 [mm]	e [mm]
75	6	IR	727 608 412	0.121	101	66	34	4,3
90	6	IR	727 608 413	0.113	101	66	45	5,1
110	6	IR	727 608 414	0.163	121	66	40	6,3

27 60 85

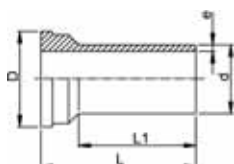

PROGEF Standard union end long SDR11

Model:

- Material: PP-H
- Conventional butt-welding according to DVS 2207 part 11
- IR = Infrared-(IR Plus®) compatible. Choose fusion parameters: PP-H
- Spigot for electro fusion
- Suitable for unions, diaphragm valves Type 314 and Vortex sensors

d [mm]	PN	FM	Code	kg	D [mm]	L [mm]	L1 [mm]	e [mm]
20	10	IR	727 608 516	0.011	30	67	52	1,9
25	10	IR	727 608 517	0.018	39	71	53	2,3
32	10	IR	727 608 518	0.024	45	73	55	2,9
40	10	IR	727 608 519	0.041	57	81	60	3,7
50	10	IR	727 608 520	0.054	63	87	66	4,6
63	10	IR	727 608 521	0.122	78	93	70	5,8

27 64 85

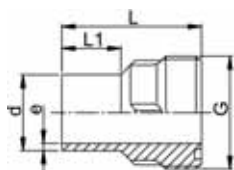

PROGEF Standard union bush SDR11

Model:

- Material: PP-H
- Conventional butt-welding according to DVS 2207 part 11
- IR = Infrared-(IR Plus®) compatible. Choose fusion parameters: PP-H
- Spigot for electro fusion

d [mm]	PN	FM	Code	kg	G [inch]	L [mm]	L1 [mm]	e [mm]
20	10	IR	727 848 506	0.012		1	54	26
25	10	IR	727 848 507	0.020		1 1/4	57	26
32	10	IR	727 848 508	0.029		1 1/2	60	25
40	10	IR	727 848 509	0.047		2	63	25
50	10	IR	727 848 510	0.062		2 1/4	66	25
63	10	IR	727 848 511	0.107		2 3/4	69	25

table continued next page

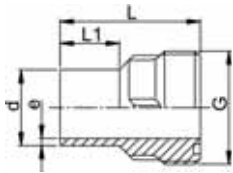

d [mm]	PN	FM	Code	kg	G [inch]	L [mm]	L1 [mm]	e [mm]
75	10	IR	727 848 512	0.172	S107.5x3.6	66	24	6.8
90	10	IR	727 848 513	0.182	S107.5x3.6	66	24	8.2
110	10	IR	727 848 514	0.258	S127.5x3.6	66	25	10.0

Union Bushes, PP-H SDR17,6

Model:

- Material: PP-H
- Conventional butt-welding according to DVS 2207 part 11
- IR = Infrared-(IR Plus®) compatible. Choose fusion parameters: PP-H
- Gasket: O-Ring EPDM No. 48 41 00
- **For the dimensions d75-110 please see instructions for the installation**

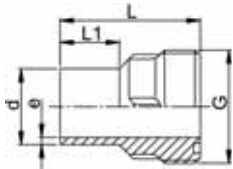

d [mm]	PN	FM	Code	kg	G [inch]	L [mm]	L1 [mm]	e [mm]
75	6	IR	727 648 412	0.150	S127.5x3.6	65.5	24	4.3
90	6	IR	727 648 413	0.147	S107.5x3.6	66.0	24	5.1
110	6	IR	727 648 414	0.200	S127.5x3.6	66.0	24	6.3

EPDM 48 41 00
FPM 49 41 00

O-Ring gasket

Model:

- For unions and adaptor unions
- Hardness approx. 65° Shore
- EPDM minimum temperature -40°C
- FPM minimum temperature -15°C

* for unions PVC-U, PVC-C and ABS: 21 51 01, 21 51 11, 21 53 03, 21 53 08, 21 55 04, 21 55 13, 21 55 18, 23 51 01 and 29 51 01 only

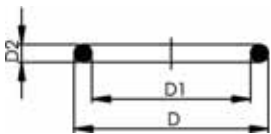

d [mm]	DN [mm]	EPDM Code	FPM Code	kg	D [mm]	D1 [mm]	D2 [mm]
10 - 12	8	748 410 004	749 410 004	0.001	18	12	2.62
16	10	748 410 005	749 410 005	0.001	21	16	2.62
20	15	748 410 006	749 410 006	0.001	27	20	3.53
25	20	748 410 007	749 410 007	0.002	35	28	3.53
32	25	748 410 008	749 410 008	0.002	40	33	3.53
40	32	748 410 009	749 410 009	0.007	51	41	5.34
50	40	748 410 010	749 410 010	0.060	58	47	5.34
63	50	748 410 011	749 410 011	0.003	70	60	5.34
75	65	748 410 014	749 410 014	0.012	93	82	5.34
90	80	748 410 015	749 410 015	0.015	112	101	5.34
* 90	80	748 410 248	749 410 248	0.020	105	95	5.34
110	100	748 410 016	749 410 016	0.031	134	120	6.99

O-Ring Gasket, FPM black

Model:

- for unions PP-H, PE100 and PVDF butt fusion
- d75 748 410 013 (EPDM), 749 410 013 (FPM)
- d90 748 410 014 (EPDM), 749 410 014 (FPM)
- d110 748 410 015 (EPDM), 749 410 015 (FPM)

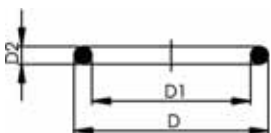

EPDM Code	FPM Code	kg	D [mm]	D1 [mm]	D2 [mm]
748 410 013	749 410 013	0.011	80		
748 410 014	749 410 014	0.012	93		
748 410 015	749 410 015	0.015	112		

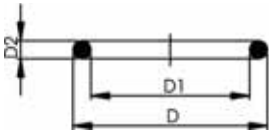

O-Ring Gaskets

Model:

- For unions and adaptor unions
- Hardness approx. 75° Shore
- FFPM minimum temperature -20°C

d [mm]	DN [mm]	FFPM Code	kg	D [mm]	D1 [mm]	D2 [mm]	
20	15	700 245 481	0.002	27	20	4	
25	20	700 245 482	0.002	35	28	4	
32	25	700 245 483	0.002	40	33	4	
40	32	700 245 484	0.006	51	41	5	
50	40	700 245 485	0.007	58	47	5	
63	50	700 245 486	0.010	70	60	5	

Flange Adaptors, Flanges and Gaskets for Butt Fusion

27 79 87

Type A



Type B

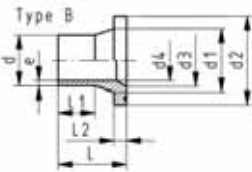
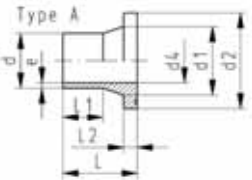

PROGEF Standard flange adaptor S5/SDR11 Combined jointing face: flat and serrated

Model:

- Material: PP-H
- Conventional butt-welding according to DVS 2207 part 11
- IR = Infrared-(IR Plus®) compatible. Choose fusion parameters: PP-H
- Suitable for flange connections to metric (**from d110 also to ANSI/ASME B16.5**)
- Up to d315, suitable for butterfly valve type 567/568
Above use PROGEF Standard Adaptor for butterfly valves SDR11 (d355-d500)
- Up to d280, suitable for butterfly valve type 037/038/039
Above use PROGEF Standard Adaptor for butterfly valves SDR11 (d315-d500)
- Gasket: Profile flange gasket EPDM No. 48 44 07, FPM No. 49 44 07
- Type A without chamfer, Type B with chamfer

d [mm]	DN [mm]	FM	Code	kg	d1 [mm]	d2 [mm]	d3 [mm]	d4 [mm]	L [mm]	L1 [mm]	L2 [mm]	e [mm]	Type
20	15	IR	727 798 706	0.015	26	45		16	50	29	7	1.9	A
25	20	IR	727 798 707	0.029	32	58		20	52	27	9	2.3	A
32	25	IR	727 798 708	0.042	40	68		26	54	28	10	2.9	A
40	32	IR	727 798 709	0.064	49	78		32	56	25	11	3.7	A
50	40	IR	727 798 710	0.091	60	88		40	62	32	12	4.6	A
63	50	IR	727 798 711	0.144	75	102		51	68	38	14	5.8	A
75	65	IR	727 798 712	0.243	89	122	66	61	80	43	16	6.9	B
90	80	IR	727 798 713	0.324	105	138	78	73	80	41	17	8.2	B
110	100	IR	727 798 714	0.441	125	158	100	90	80	40	18	10.0	B
125	100	IR	727 798 715	0.487	132	158	114	102	82	35	25	11.4	B
140	125	IR	727 798 716	0.800	155	188	127	114	89	39	25	12.8	B
160	150	IR	727 798 717	0.920	175	212	151	131	92	45	25	14.6	B
180	150	IR	727 798 718	0.892	180	212	154	147	80	45	30	16.4	B
200	200	IR	727 798 719	1.670	232	268	203	163	100	30	32	18.2	B
225	200	IR	727 798 720	1.665	235	268	210	184	100	35	32	20.5	B
250	250		727 798 721	2.630	285	320	250	204	100	25	35	22.7	B
280	250		727 798 722	2.521	291	320	265	229	100	35	35	25.4	B
315	300		727 798 723	3.247	335	370	300	257	100	25	35	28.6	B
355	350		727 798 724	7.572	373	430	340	290	180	40	40	32.2	B
400	400		727 798 725	10.201	427	482	385	327	187	46	46	36.3	B
450	500		727 798 726	13.800	514	585	400	368	141	64	60	40.9	B
500	500		727 798 727	12.553	530	587	440	409	138	62	61	45.4	B

277986

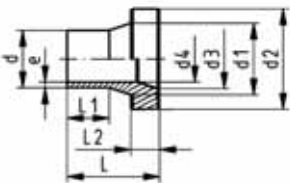

PROGEF Standard adaptor for butterfly valves SDR11 Jointing face flat metric

Model:

- Material: Polypropylene, PP-R
- Conventional butt-welding according to DVS 2207 part 11
- Suitable for butterfly valves type 567/568 and 037/038/039

Note:

* available starting Q1 2013

d [mm]	DN [mm]	Code	kg	d1 [mm]	d2 [mm]	d3 [mm]	d4 [mm]	L [mm]	L1 [mm]	L2 [mm]	e [mm]
* 315	300	727 798 623									
355	350	727 798 624	7.435	373	430	346	312	180	90	65	32.2
400	400	727 798 625	9.618	427	482	404	352	196	95	69	36.3
450	450	727 798 626	12.810	467	533	460	396	195	60	108	40.9
500	500	727 798 627	14.267	530	585	500	440	188	60	90	45.4

PROGEF Standard flange adaptor S5/SDR11 Combined jointing face: flat and serrated

Model:

- Material: PP-H
- Conventional butt-welding according to DVS 2207 part 11
- IR = Infrared-(IR Plus®) compatible. Choose fusion parameters: PP-H
- Suitable for flange connections to **ANSI/ASME B 16.5**
- Up to d280, suitable for butterfly valve type 567/568 and 037/038/039
- Gasket: Profile flange gasket EPDM No. 48 44 07, FPM No. 49 44 07

* Type B with chamfer

d [mm]	DN [mm]	FM	Code	kg	d1 [mm]	d2 [mm]	d3 [mm]	d4 [mm]	L [mm]	L1 [mm]	L2 [mm]	e [mm]
20	15	IR	727 798 706	0.015	26	45		16	50	29	7	1.9
25	20	IR	727 798 757	0.022	33	54		20	52	27	9	2.3
32	25	IR	727 798 758	0.039	40	63		26	54	28	10	3.0
40	32	IR	727 798 759	0.056	50	73		32	56	25	11	3.7
50	40	IR	727 798 760	0.087	61	82		40	62	32	12	4.6
63	50	IR	727 798 711	0.144	75	102		51	68	38	14	5.8
75	65	IR	727 798 712	0.243	89	122	66	61	80	43	16	6.9
* 90	80	IR	727 798 763	0.310	105	133	78	73	80	41	17	8.2
110	100	IR	727 798 714	0.441	125	158	100	90	80	40	18	10.0
125	100	IR	727 798 715	0.487	132	158	114	102	82	35	25	11.4
140	125	IR	727 798 716	0.800	155	188	127	114	89	39	25	12.8
160	150	IR	727 798 717	0.920	175	212	151	131	92	45	25	14.6
180	150	IR	727 798 718	0.892	180	212	154	147	80	45	30	16.4
200	200	IR	727 798 719	1.670	232	268	203	163	100	30	32	18.2
225	200	IR	727 798 720	1.665	235	268	210	184	100	35	32	20.5
250	250		727 798 721	2.630	285	320	250	204	100	25	35	22.7
280	250		727 798 722	2.521	291	320	265	229	100	35	35	25.4
315	300		727 798 723	3.247	335	370	300	257	100	25	35	28.6
355	350		727 798 724	7.572	373	430	340	290	180	40	40	32.2
400	400		727 798 725	10.201	427	482	385	327	187	46	46	36.3

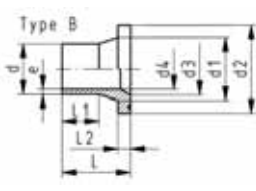
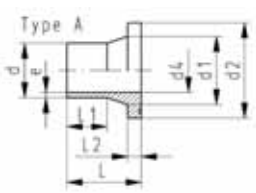

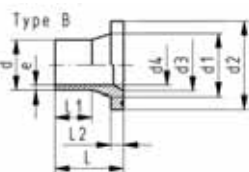
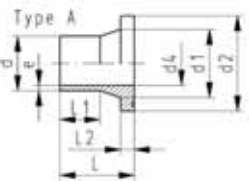

PROGEF Standard flange adaptor S8.3/SDR17.6 Combined jointing face: flat and serrated

Model:

- Material: PP-H
- Conventional butt-welding according to DVS 2207 part 11
- IR = Infrared-(IR Plus®) compatible. Choose fusion parameters: PP-H
- Suitable for flange connections to metric (**from d110 also to ANSI/ASME B16.5**)
- Up to d315, suitable for butterfly valve type 567/568
Above use PROGEF Standard Adaptor for butterfly valves SDR17.6 (d355-d500)
- Up to d280, suitable for butterfly valve type 037/038/039
Above use PROGEF Standard Adaptor for butterfly valves SDR17.6 (d315-d500)
- Gasket: Profile flange gasket EPDM No. 48 44 07, FPM No. 49 44 07
- Type A without chamfer, Type B with chamfer

d [mm]	DN [mm]	FM	Code	kg
50	40	IR	727 798 785	0.077
63	50	IR	727 798 786	0.116
75	65	IR	727 798 787	0.204
90	80	IR	727 798 788	0.273
110	100	IR	727 798 789	0.361
125	100	IR	727 798 790	0.356
140	125	IR	727 798 791	0.526
160	150	IR	727 798 792	0.761
180	150	IR	727 798 793	0.630
200	200	IR	727 798 794	1.462
225	200	IR	727 798 795	1.330
250	250		727 798 796	1.800
280	250		727 798 797	1.785
315	300		727 798 798	2.499
355	350		727 798 799	5.251
400	400		727 798 800	7.700
450	500		727 798 801	10.200
500	500		727 798 802	9.300

d [mm]	d1 [mm]	d2 [mm]	d3 [mm]	d4 [mm]	L [mm]	L1 [mm]	L2 [mm]	e [mm]	Type
50	61	88		42	50	21	12	2.9	A
63	75	102		53	50	16	14	3.6	A
75	89	122		65	80	43	16	4.3	A
90	105	138		78	80	41	17	5.1	A
110	125	158		96	80	40	18	6.3	A
125	132	158	114	107	80	42	18	7.4	B
140	155	188	127	120	80	34	18	8.0	B
160	175	212	158	142	92	45	25	9.1	B
180	180	212		156	80	30	20	10.2	A
200	232	268	203	177	100	30	32	11.4	B
225	235	268	210	199	100	35	32	12.8	B
250	285	320	250	216	100	25	25	14.2	B
280	291	320	265	243	100	45	25	15.9	B
315	335	370	300	274	100	35	25	17.9	B
355	374	431	340	314	182	100	30	20.1	B
400	428	484	385	353	199	110	33	22.7	B
450	514	585		396	140	586	46	25.5	A
500	530	585		440	141	585	47	28.3	A

277986

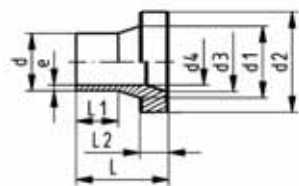

PROGEF Standard adaptor for butterfly valves SDR17.6 Jointing face flat metric

Model:

- Material: Polypropylene, PP-R
- Conventional butt-welding according to DVS 2207 part 11
- Suitable for butterfly valves type 567/568 and 037/038/039

Note:

* available starting Q1 2013

d [mm]	DN [mm]	Code	kg	d1 [mm]	d2 [mm]	d3 [mm]	d4 [mm]	L [mm]	L1 [mm]	L2 [mm]	e [mm]
* 315	300	727 798 648									
355	350	727 798 649	6.010	373	430	346	312	180	90	65	20.1
400	400	727 798 650	7.884	427	482	404	352	196	95	69	22.7
450	450	727 798 651	8.951	467	533	460	396	195	60	108	25.5
500	500	727 798 652	7.737	530	585	500	440	144	60	90	28.3

27 80 80

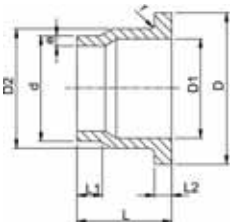

PROGEF Standard outlet flange adaptor S5/SDR11

Model:

- Material: Polypropylene, PP-R
- Conventional butt-welding according to DVS 2207 part 11
- To wafer check valves Type 369

Attention:

- In conjunction with outlet flange adaptors, **flange rings for socket systems** must be used.

d [mm]	DN [mm]	Code	kg	D [mm]	D1 [mm]	D2 [mm]	L [mm]	L1 [mm]	L2 [mm]	e [mm]	r [mm]
40	32	727 808 034	0.064	80	37	50	64	30	11	3,7	3
50	40	727 808 035	0.096	90	43	61	67	30	12	4,6	3
63	50	727 808 036	0.157	105	54	76	74	30	14	5,8	4
75	65	727 808 037	0.223	125	70	90	78	30	16	6,8	4
90	80	727 808 038	0.325	140	82	108	87	35	17	8,2	4
110	100	727 808 039	0.475	160	105	131	102	41	18	10,0	4
140	125	727 808 041	0.899	190	130	165	124	47	25	12,7	4
160	150	727 808 042	1.246	215	158	188	149	52	25	14,6	4
225	200	727 808 045	2.638	270	206	248	180	55	32	20,5	4
280	250	727 808 047	4.088	325	259	308	240	63	35	25,4	4
315	300	727 808 048	4.960	375	308	346	272	66	35	28,6	4

27 80 80

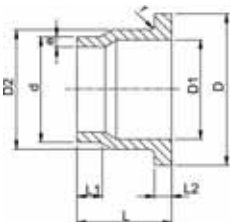

PROGEF Standard outlet flange adaptor S8.3/SDR17.6

Model:

- Material: Polypropylene, PP-R
- Conventional butt-welding according to DVS 2207 part 11
- To wafer check valves Type 369

Attention:

- In conjunction with outlet flange adaptors, **flange rings for socket systems** must be used.

d [mm]	DN [mm]	Code	kg	D [mm]	D1 [mm]	D2 [mm]	L [mm]	L1 [mm]	L2 [mm]	e [mm]	r [mm]
40	32	727 808 009	0.048	80	37	50	64	30	11	2,3	3
50	40	727 808 010	0.091	90	43	61	67	30	12	2,9	3
63	50	727 808 011	0.096	105	54	76	74	30	14	3,6	4
75	65	727 808 012	0.170	125	70	90	78	30	16	4,3	4
90	80	727 808 013	0.260	140	82	108	87	35	17	5,1	4
110	100	727 808 014	0.355	160	105	131	102	41	18	6,3	4
140	125	727 808 016	0.808	190	130	165	124	47	18	8,0	4
160	150	727 808 017	1.107	215	158	188	149	52	18	9,1	4
225	200	727 808 020	1.225	270	206	248	180	55	24	12,7	4
280	250	727 808 022	3.563	325	259	308	240	63	25	15,9	4
315	300	727 808 023	2.450	375	308	346	272	66	25	17,9	4

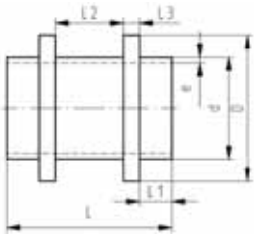
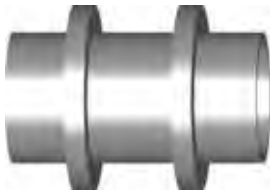

PROGEF Standard fixed point fitting S5/SDR11

Model:

- Material: PP-H
- Conventional butt-welding according to DVS 2207 part 11
- IR = Infrared-(IR Plus®) compatible. Choose fusion parameters: PP-H
- Machined

d [mm]	FM	Code	kg	D [mm]	L [mm]	L1 [mm]	L2 [mm]	L3 [mm]	e [mm]
63	IR	727 665 520	0.175	90	122	30	42	10	5.8
75	IR	727 665 521	0.254	110	122	30	42	10	6.8
90	IR	727 665 522	0.342	125	122	30	42	10	8.2
110	IR	727 665 523	0.567	140	142	30	52	15	10.0
125	IR	727 665 524	0.777	160	152	35	52	15	11.4
140	IR	727 665 525	1.023	180	162	40	52	15	12.7
160	IR	727 665 526	1.292	200	162	40	52	15	14.6
180	IR	727 665 527	1.917	225	182	45	52	20	16.4
200	IR	727 665 528	2.365	250	182	45	52	20	18.2
225	IR	727 665 529	3.294	280	192	45	52	25	20.5
250	--	727 665 530	3.695	280	212	50	62	25	22.7
280	--	727 665 531	4.997	315	222	50	62	30	25.4
315	--	727 665 532	6.348	355	222	50	62	30	28.6
355	--	727 665 533	7.405	400	192	30	62	35	32.2
400	--	727 665 534	10.432	450	212	30	72	40	36.3
450	--	727 665 535	14.153	500	232	35	72	45	40.9
500	--	727 665 536	19.414	560	252	40	72	50	45.4

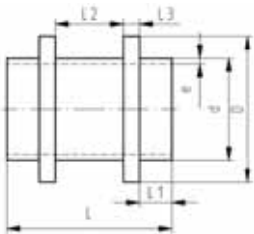
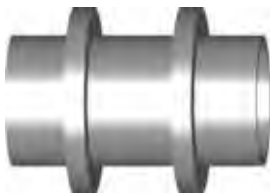

PROGEF Standard fixed point fitting S8 3/SDR17 6

Model:

- Material: PP-H
- Conventional butt-welding according to DVS 2207 part 11
- IR = Infrared-(IR Plus®) compatible. Choose fusion parameters: PP-H
- Machined

d [mm]	FM	Code	kg	D [mm]	L [mm]	L1 [mm]	L2 [mm]	L3 [mm]	e [mm]
63	IR	727 665 539	0.138	90	122	30	42	10	3.8
75	IR	727 665 540	0.203	110	122	30	42	10	4.5
90	IR	727 665 541	0.267	125	122	30	42	10	5.4
110	IR	727 665 542	0.438	140	142	30	52	15	6.6
125	IR	727 665 543	0.592	160	152	35	52	15	7.4
140	IR	727 665 544	0.781	180	162	40	52	15	8.3
160	IR	727 665 545	0.971	200	162	40	52	15	9.5
180	IR	727 665 546	1.464	225	182	45	52	20	10.7
200	IR	727 665 547	1.808	250	182	45	52	20	11.9
225	IR	727 665 548	2.549	280	192	45	52	25	13.4
250	--	727 665 549	2.678	280	212	50	62	25	14.8
280	--	727 665 550	3.668	315	222	50	62	30	16.6
315	--	727 665 551	4.666	355	222	50	62	30	18.7
355	--	727 665 552	5.567	400	192	30	62	35	21.1
400	--	727 665 553	7.835	450	212	30	72	40	23.7
450	--	727 665 554	10.552	500	232	35	72	45	26.7
500	--	727 665 555	14.608	560	252	40	72	50	29.7

27 70 06

Blanking flange set PP-H Combined jointing face flat and serrated metric

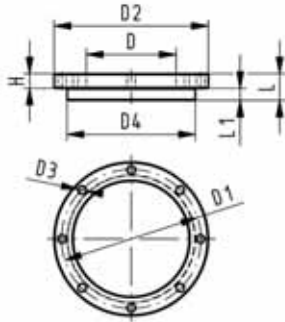

Model:

- d63 - d315: Backing Flange PP-V with End Blank PP-H
- d355 - d630: Backing Flange PP/Steel with End Blank PP-H
- Connecting dimensions: ISO 7005, EN 1092, DIN 2501
- **Bolt circle PN 10**

AL: number of holes

L: length of the End Blank

d [mm]	DN [mm]	PN	Code	kg	D [mm]	D1 [mm]	D2 [mm]	D3 [mm]	D4 [mm]	H [mm]	L [mm]	L1 [mm]	AL
63	50	10	727 700 611	0.531	75	125	165	18	102	24	30	14	4
75	65	10	727 700 612	0.901	89	145	185	18	122	26	30	16	4
90	80	10	727 700 613	1.054	105	160	200	18	138	27	30	17	8
110	100	10	727 700 614	1.199	125	180	220	18	158	28	30	18	8
125	100	10	727 700 615	1.201	132	180	220	18	158	28	35	25	8
140	125	10	727 700 616	1.748	155	210	250	18	188	30	40	25	8
160	150	10	727 700 617	2.312	175	240	285	22	212	32	40	25	8
180	150	10	727 700 618	2.443	180	240	285	22	212	32	45	30	8
200	200	10	727 700 619	3.961	232	295	340	22	268	34	50	32	8
225	200	10	727 700 620	3.956	235	295	340	22	268	34	50	32	8
250	250	10	727 700 621	5.425	285	350	395	22	320	38	55	35	12
280	250	10	727 700 622	19.781	291	350	395	22	320	38	60	35	12
315	300	10	727 700 623	8.602	335	400	445	22	370	42	65	35	12
355	350	10	727 700 624	23.184	373	460	515	22	430	40	70	40	16
400	400	10	727 700 625	30.304	427	515	574	26	482	40	75	46	16
450	500	10	727 700 626	43.485	510	620	684	26	585	49	80	60	20
500	500	10	727 700 627	46.203	530	620	684	26	585	49	90	60	20
560	600	10	727 700 628	65.823	615	725	796	30	685	58	100	60	20
630	600	10	727 700 629	67.056	642	725	796	30	685	58	110	60	20

Blanking Flanges PP-H

Model:

- made out of sheet material
- **Bolt circle PN 10**

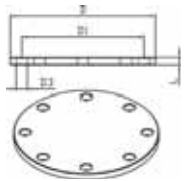

d [mm]	DN [mm]	PN	Code	L [mm]	D [mm]	D1 [mm]	D3 [mm]	AL
63	50	2,5	700 647 829	15	165	125	18	4
75	65	2,5	700 647 830	15	185	145	18	4
90	80	2,5	700 647 831	15	200	160	18	8
110	100	2,5	700 647 832	15	220	180	18	8
125	100	2,5	700 647 833	20	220	180	18	8
140	125	2,5	700 647 834	25	250	210	18	8
160	150	2,5	700 647 835	25	285	240	22	8
180	150	2,5	700 647 836	30	285	240	22	8
200	200	2,5	700 647 837	35	340	295	22	8
225	200	2,5	700 647 838	35	340	295	22	8
250	250	2,5	700 647 839	40	395	350	22	12
280	250	2,5	700 647 840	45	395	350	22	12
315	300	2,5	700 647 841	50	445	400	22	12
355	350	2,5	700 647 842	55	515	460	22	16
400	400	2,5	700 647 843	65	574	515	26	16
450	500	2,5	700 647 844	65	670	620	26	20
500	500	2,5	700 647 845	75	670	620	26	20
560	600	2,5	700 647 846	85	780	725	30	20
630	600	2,5	700 647 847	95	780	725	30	20

27 70 04
27 70 05

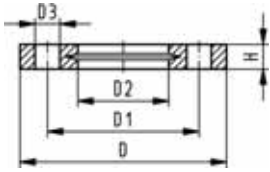

Backing flange PP-V For butt fusion systems metric

Model:

- Modern full-plastic flange PP-GF (30 % glass-fibre reinforced)
- With V-groove which applies force evenly on collar
- With integrated bolt retainers as an assembly aid
- UV-resistant. Applicable for outside applications
- Connecting dimension: ISO 7005, EN 1092, BS 4504, DIN 2501
- **Bolt circle PN 10**

* Combined version, metric-ANSI

AL: number of holes

1) Suitable for socket- and butt fusion systems (no pictograph on flange)

d [mm]	DN [mm]	PN	Code	kg	D [mm]	D1 [mm]	D2 [mm]	D3 [mm]	H [mm]	AL	SC
1) 20	15	16	727 700 406	0.093	95	65.0	28	14	16	4	M12
1) 25	20	16	727 700 407	0.120	105	75.0	34	14	17	4	M12
1) 32	25	16	727 700 408	0.151	115	85.0	42	14	18	4	M12
1) 40	32	16	727 700 409	0.244	140	100.0	51	18	20	4	M16
1) 50	40	16	727 700 410	0.297	150	110.0	62	18	22	4	M16
1) 63	50	16	727 700 411	0.362	165	125.0	78	18	24	4	M16
1) 75	65	16	727 700 412	0.487	185	145.0	92	18	26	4	M16
90	80	16	727 700 513	0.544	200	160.0	108	18	27	8	M16
110	100	16	727 700 514	0.643	220	180.0	128	18	28	8	M16
125	100	16	727 700 515	0.635	220	180.0	135	18	28	8	M16
140	125	16	727 700 516	0.842	250	210.0	158	18	30	8	M16
180	150	16	727 700 518	1.200	285	240.0	188	22	32	8	M20
250	250	16	727 700 521	2.052	395	350.0	288	22	38	12	M20
280	250	16	727 700 522	1.700	395	350.0	294	22	38	12	M20
315	300	16	727 700 523	2.400	445	400.0	338	22	42	12	M20
355	350	10	727 700 524	4.440	515	460.0	376	22	46	16	M20
400	400	10	727 700 525	5.624	574	515.0	430	26	50	16	M24

27 70 04
27 70 05

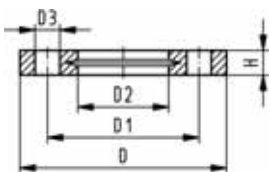

Backing flange PP-V For socket systems metric

Model:

- Modern full-plastic flange PP-GF (30 % glass-fibre reinforced)
- With V-groove which applies force evenly on collar
- With integrated bolt retainers as an assembly aid
- UV-resistant. Applicable for outside applications
- Connecting dimension: ISO 7005, EN 1092, BS 4504, DIN 2501
- **Bolt circle PN 10**

* Combined version, metric-ANSI

AL: number of holes

1) Suitable for socket- and butt fusion systems (no pictograph on flange)

d [mm]	DN [mm]	PN	Code	kg	D [mm]	D1 [mm]	D2 [mm]	D3 [mm]	H [mm]	AL	SC
1) 20	15	16	727 700 406	0.093	95	65.0	28	14	16	4	M12
1) 25	20	16	727 700 407	0.120	105	75.0	34	14	17	4	M12
1) 32	25	16	727 700 408	0.151	115	85.0	42	14	18	4	M12
1) 40	32	16	727 700 409	0.244	140	100.0	51	18	20	4	M16
1) 50	40	16	727 700 410	0.297	150	110.0	62	18	22	4	M16
1) 63	50	16	727 700 411	0.362	165	125.0	78	18	24	4	M16
1) 75	65	16	727 700 412	0.487	185	145.0	92	18	26	4	M16
90	80	16	727 700 413	0.550	200	160.0	110	18	27	8	M16
110	100	16	727 700 414	0.640	220	180.0	133	18	28	8	M16

27 70 14
27 70 15

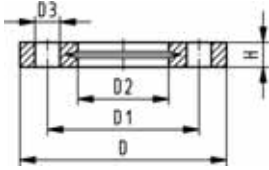

Backing flange PP-V For butt fusion systems Inch ANSI

Model:

- Modern full-plastic flange PP-GF (30 % glass-fibre reinforced)
- With V-groove which applies force evenly on collar
- With integrated bolt-fixing as an assembly aid
- UV-resistant. Applicable for outside applications
- Connecting dimension: ANSI/ASME B 16.5 class 150, ASTM D 4024, BS 1560, BS EN 1759
- **Bolt circle class 150**

1) Suitable for socket- and butt fusion systems (no pictograph on flange)

AL: number of holes

* Combined version, metric-ANSI

Inch	DN [mm]	d [mm]	PN	Code	kg	D [mm]	D1 [mm]	D2 [mm]	D3 [mm]	H [mm]	AL	SC
1/2	15	20	16	727 701 406	0.091	95	60.0	28	16	16	4	M12
3/4	20	25	16	727 701 407	0.120	105	70.0	34	16	17	4	M12
1	25	32	16	727 701 408	0.147	115	79.0	42	16	18	4	M12
1 1/4	32	40	16	727 701 409	0.246	140	89.0	51	16	20	4	M16
1 1/2	40	50	16	727 701 410	0.299	150	98.0	62	16	22	4	M16
2	50	63	16	727 701 411	0.361	165	121.0	78	19	24	4	M16
2 1/2	65	75	16	727 701 412	0.492	185	140.0	92	19	26	4	M16
3	80	90	16	727 701 513	0.607	200	152.0	108	19	27	4	M16
4	100	110	16	727 701 514	0.736	229	190.0	128	19	28	8	M16
10	250	250	16	727 701 521	2.241	406	362.0	288	26	38	12	M20
10	250	280	16	727 701 522	2.173	406	362.0	294	26	38	12	M20
12	300	315	16	727 701 523	3.627	483	432.0	338	26	42	12	M20

27 70 14
27 70 15

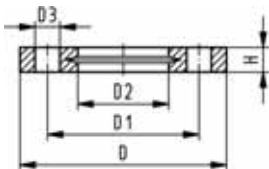

Backing flange PP-V For socket systems Inch ANSI

Model:

- Modern full-plastic flange PP-GF (30 % glass-fibre reinforced)
- With V-groove which applies force evenly on collar
- With integrated bolt-fixing as an assembly aid
- UV-resistant. Applicable for outside applications
- Connecting dimension: ANSI/ASME B 16.5 class 150, ASTM D 4024, BS 1560, BS EN 1759
- **Bolt circle class 150**
- 727701414, 727700417, 727700419: only for use with original metric flange adaptors

1) Suitable for socket- and butt fusion systems (no pictograph on flange)

AL: number of holes

* Combined version, metric-ANSI

Inch	DN [mm]	d [mm]	PN	Code	kg	D [mm]	D1 [mm]	D2 [mm]	D3 [mm]	H [mm]	AL	SC
1/2	15	20	16	727 701 406	0.091	95	60.0	28	16	16	4	M12
3/4	20	25	16	727 701 407	0.120	105	70.0	34	16	17	4	M12
1	25	32	16	727 701 408	0.147	115	79.0	42	16	18	4	M12
1 1/4	32	40	16	727 701 409	0.246	140	89.0	51	16	20	4	M16
1 1/2	40	50	16	727 701 410	0.299	150	98.0	62	16	22	4	M16
2	50	63	16	727 701 411	0.361	165	121.0	78	19	24	4	M16
2 1/2	65	75	16	727 701 412	0.492	185	140.0	92	19	26	4	M16
3	80	90	16	727 701 413	0.605	200	152.0	110	19	27	4	M16
4	100	110	16	727 701 414	0.704	229	190.0	133	19	28	8	M16

27 70 02
27 70 03

Backing flange PP-Steel For butt fusion systems metric

Model:

- Material: PP (30 % glass-fibre reinforced) with steel ring
- UV-resistant. Applicable for outside applications
- Connecting dimension: ISO 7005, EN 1092, BS 4504, DIN 2501
- **Bolt circle PN 10**

AL: number of holes

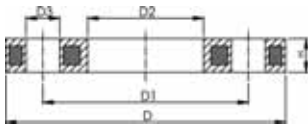
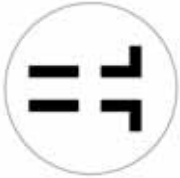

d [mm]	DN [mm]	PN	Code	kg	D [mm]	D1 [mm]	D2 [mm]	D3 [mm]	H [mm]	AL	SC
20	15	16	727 700 206	0.216	95	65	28	14	12	4	M12
25	20	16	727 700 207	0.279	105	75	34	14	12	4	M12
32	25	16	727 700 208	0.429	115	85	42	14	16	4	M12
40	32	16	727 700 209	0.621	140	100	51	18	16	4	M16
50	40	16	727 700 210	0.722	150	110	62	18	20	4	M16
63	50	16	727 700 211	1.084	165	125	78	18	20	4	M16
75	65	16	727 700 212	1.349	185	145	92	18	20	4	M16
90	80	16	727 700 313	1.390	200	160	108	18	20	8	M16
110	100	16	727 700 314	1.407	220	180	128	18	20	8	M16
125	100	16	727 700 315	1.408	220	180	135	18	20	8	M16
140	125	16	727 700 316	2.318	250	210	158	18	24	8	M16
180	150	16	727 700 318	3.108	285	240	188	22	24	8	M20
200	200	16	727 700 319	5.600	340	295	235	22	27	8	M20
225	200	16	727 700 320	5.533	340	295	238	22	27	8	M20
250	250	16	727 700 321	6.632	395	350	288	22	30	12	M20
280	250	16	727 700 322	6.573	395	350	294	22	30	12	M20
315	300	16	727 700 323	7.903	445	400	338	22	34	12	M20
355	350	16	727 700 324	14.587	515	460	376	22	40	16	M20
400	400	16	727 700 325	20.034	574	515	430	26	40	16	M24

27 70 12

Backing flange PP-Steel For butt fusion systems Inch ANSI

Model:

- Material: PP (30 % glass-fibre reinforced) with steel ring
- UV-resistant. Applicable for outside applications
- Connecting dimension: ANSI/ASME B 16.5 class 150, ASTM D 4024, BS 1560, BS EN 1759
- **Bolt circle class 150**

AL: number of holes

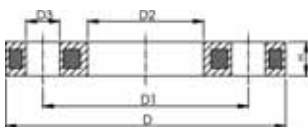

d [inch]	DN [mm]	d [mm]	PN	Code	kg	D1 [mm]	D2 [mm]	D3 [mm]	D [mm]	H [mm]	AL	SC
½	15	20	16	727 701 206	0.213	60	28	16	95	12	4	M12
¾	20	25	16	727 701 207	0.260	70	34	16	105	12	4	M12
1	25	32	16	727 701 208	0.416	79	42	16	115	16	4	M12
1 ¼	32	40	16	727 701 209	0.730	89	51	16	140	16	4	M16
1 ½	40	50	16	727 701 210	0.809	98	62	16	150	18	4	M16
2	50	63	16	727 701 211	0.866	121	78	19	165	18	4	M16
2 ½	65	75	16	727 701 212	1.117	140	92	19	185	18	4	M16
3	80	90	16	727 701 313	1.499	152	108	19	200	20	4	M16
4	100	110	16	727 701 314	1.739	190	128	19	229	20	8	M16
8	200	200	16	727 701 319	5.440	298	235	22	340	27	8	M20
8	200	225	16	727 701 320	5.621	298	238	22	340	27	8	M20

24 70 04

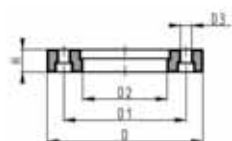

Profiled backing flange PP/Steel For butt fusion systems metric

Model:

- PP with glass-fibre reinforcement and GGG 50 insert
- UV-resistant. Applicable for outside applications
- Connecting dimensions: ISO 7005, EN 1092, DIN 2501
- **Bolt circle PN 10**

Note:

flat side = bolt side
profiled side = flange adaptor side

AL: number of holes

* Galvanized steel, suitable for underground laying

d [mm]	DN [mm]	PN	Code	kg	D [mm]	D1 [mm]	D2 [mm]	D3 [mm]	H [mm]	AL	SC
450	500	10	724 700 426	25.600	685	620	517	26	54	20	M24
500	500	10	724 700 427	21.061	685	620	533	26	54	20	M24
560	600	10	724 700 428	35.000	796	725	618	30	64	20	M27
630	600	10	724 700 429	32.500	800	725	645	30	58	20	M27
710	700	6	724 700 430	28.600	912	840	740	30	49	24	M27
800	800	6	724 700 431	39.300	1026	950	843	33	58	24	M30
900	900	6	724 700 432	48.500	1129	1050	947	33	62	28	M30

EPDM 48 44 07
FPM 49 44 07

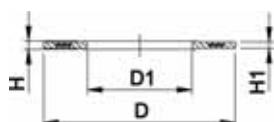

Profile flange gasket metric

Model:

- For all metric GF Flange Adaptors
- Profile Gasket with steel insert (type G-ST-P/K)
- Hardness: 70° Shore **EPDM**, 75° Shore **FPM**
- **EPDM**: approved acc. to DVGW W 270, KTW recommendation
- Centering on the inner diameter of the screw crown
- material steel insert: carbon steel

di FA are the suitable inner diameters of flange adaptors

d [mm]	DN [mm]	PN	EPDM Code	FPM Code	kg	D [mm]	D1 [mm]	H [mm]	H1 [mm]	di FA [mm]
16	10	16	748 440 705	749 440 705	0.012	46	16	4	3	6 - 16
20	15	16	748 440 706	749 440 706	0.013	51	20	4	3	10 - 20
25	20	16	748 440 707	749 440 707	0.014	61	22	4	3	12 - 22
32	25	16	748 440 708	749 440 708	0.019	71	28	4	3	18 - 28
40	32	16	748 440 709	749 440 709	0.026	82	40	4	3	30 - 40
50	40	16	748 440 710	749 440 710	0.039	92	46	4	3	36 - 46
63	50	16	748 440 711	749 440 711	0.050	107	58	5	4	48 - 58
75	65	16	748 440 712	749 440 712	0.082	127	69	5	4	59 - 69
90	80	16	748 440 713	749 440 713	0.083	142	84	5	4	73 - 84
110	100	16	748 440 714	749 440 714	0.127	162	104	6	5	94 - 104
125	100	16	748 440 715	749 440 715	0.105	162	123	6	5	113 - 123
140	125	16	748 440 716	749 440 716	0.173	192	137	6	5	127 - 137
160 / 180	150	16	748 440 717	749 440 717	0.207	218	160	8	6	150 - 160
200	200	16	748 440 719	749 440 719	0.263	273	203	8	6	192 - 203
225	200	16	748 440 720	749 440 720	0.255	273	220	8	6	207 - 220
250	250	16	748 440 721	749 440 721	0.482	328	252	8	6	238 - 252
280	250	16	748 440 722	749 440 722	0.323	328	274	8	6	264 - 274
315	300	16	748 440 723	749 440 723	0.549	378	306	8	6	296 - 306
355	350	16	748 440 724	749 440 724	0.870	438	355	10	7	340 - 355
400	400	16	748 440 725	749 440 725	1.088	489	400	10	7	385 - 400
450	500	16	748 440 726	749 440 726	0.718	594	403	10	7	393 - 403
500	500	16	748 440 727	749 440 727	0.718	594	447	10	7	437 - 447
560	600	16	748 440 728	749 440 728	0.923	695	494	10	7	484 - 494
630	600	16	748 440 729	749 440 729	0.923	695	555	10	7	545 - 555

Fittings for Socket Fusion

27 10 01

PROGEF Standard elbow 90°

Model:

- Material: PP-H
- * use pipe SDR 7.4

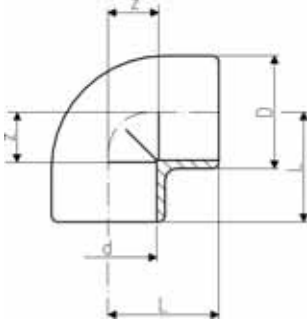

d [mm]	PN	Code	kg	D [mm]	L [mm]	z [mm]
* 16	10	727 100 105	0.014	26	25	12
20	10	727 100 106	0.020	31	28	14
25	10	727 100 107	0.029	36	32	16
32	10	727 100 108	0.044	44	38	20
40	10	727 100 109	0.071	54	44	24
50	10	727 100 110	0.121	66	51	28
63	10	727 100 111	0.228	82	62	35
75	10	727 100 112	0.301	93	76	45
90	10	727 100 113	0.477	110	88	53
110	10	727 100 114	0.869	134	106	65

27 15 01

PROGEF Standard elbow 45°

Model:

- Material: PP-H
- * use pipe SDR 7.4

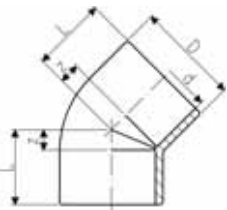

d [mm]	PN	Code	kg	D [mm]	L [mm]	z [mm]
* 16	10	727 150 105	0.009	23	20	7
20	10	727 150 106	0.016	31	21	7
25	10	727 150 107	0.024	36	24	8
32	10	727 150 108	0.036	44	28	10
40	10	727 150 109	0.059	53	33	13
50	10	727 150 110	0.084	64	36	13
63	10	727 150 111	0.183	82	43	16
75	10	727 150 112	0.219	93	51	20
90	10	727 150 113	0.336	114	58	23
110	10	727 150 114	0.657	134	68	27

27 20 01

PROGEF Standard tee 90° equal

Model:

- Material: PP-H
- * use pipe SDR 7.4

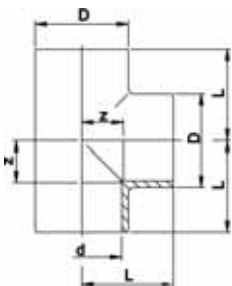

d [mm]	PN	Code	kg	D [mm]	L [mm]	z [mm]
* 16	10	727 200 105	0.020	26	25	12
20	10	727 200 106	0.027	31	28	14
25	10	727 200 107	0.039	36	32	16
32	10	727 200 108	0.057	44	38	20
40	10	727 200 109	0.095	54	44	24
50	10	727 200 110	0.161	66	51	28
63	10	727 200 111	0.286	82	62	35
75	10	727 200 112	0.390	93	76	45
90	10	727 200 113	0.727	114	88	53
110	10	727 200 114	1.062	134	106	65

27 91 01

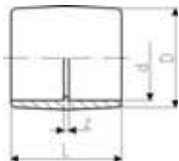

PROGEF Standard socket equal

Model:

- Material: PP-H
- * use pipe SDR 7.4

d [mm]	PN	Code	kg	D [mm]	L [mm]	z [mm]
* 16	10	727 910 105	0.010	26	33	7
20	10	727 910 106	0.013	31	35	7
25	10	727 910 107	0.019	36	39	7
32	10	727 910 108	0.026	44	43	7
40	10	727 910 109	0.041	54	48	8
50	10	727 910 110	0.072	66	54	8
63	10	727 910 111	0.118	82	62	8
75	10	727 910 112	0.147	93	70	8
90	10	727 910 113	0.238	112	81	11
110	10	727 910 114	0.425	134	96	14

27 91 09

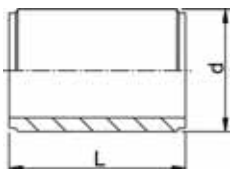

PROGEF Standard barrel nipple

Model:

- Material: PP-H
- With fusion sockets on both sides
- For the shortest possible distance between fittings
- Overall length L = 2 x fusion length

* In these two sizes, stiffeners Code No. 727 900 006 (20 x 1.9) and 727 900 007 (25 x 2.3), or pipe SDR 7.4 must be used with socket fusion joints.

d [mm]	PN	Code	kg	L [mm]	e [mm]
* 20	10	727 910 906	0.005	37	1.9
* 25	10	727 910 907	0.006	41	2.3
32	10	727 910 908	0.010	45	2.9
40	10	727 910 909	0.017	50	3.7
50	10	727 910 910	0.029	55	4.6
63	10	727 910 911	0.058	64	5.8
75	10	727 910 912	0.095	76	6.8
90	10	727 910 913	0.163	90	8.2
110	10	727 910 914	0.305	108	10.0

27 91 03

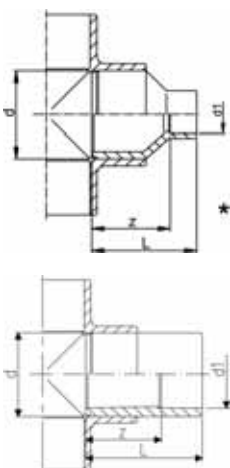

PROGEF Standard reducer

Model:

- Material: PP-H

Note:

* Fusion spigot and socket

d [mm]	d1 [mm]	PN	Code	kg	L [mm]	z [mm]
20	16	10	727 910 334	0.013	35	22
25	16	10	727 910 338	0.010	38	25
25	20	10	727 910 337	0.012	37	23
32	20	10	727 910 342	0.016	43	29
32	25	10	727 910 341	0.019	43	27
* 40	20	10	727 910 348	0.022	48	34
* 40	25	10	727 910 347	0.025	48	32
40	32	10	727 910 346	0.030	48	30
* 50	20	10	727 910 355	0.034	54	40
* 50	25	10	727 910 354	0.034	54	38
* 50	32	10	727 910 353	0.039	54	36
50	40	10	727 910 352	0.048	54	34
* 63	25	10	727 910 361	0.054	64	46
* 63	32	10	727 910 360	0.062	64	46
* 63	40	10	727 910 359	0.069	64	44
63	50	10	727 910 358	0.083	64	41
75	63	10	727 910 364	0.098	62	35

table continued next page

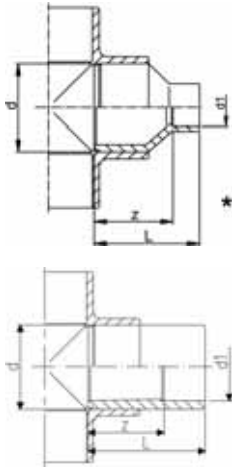

d [mm]	d1 [mm]	PN	Code	kg	L [mm]	z [mm]
* 90	63	10	727 910 371	0.170	88	61
90	75	10	727 910 370	0.142	70	39
110	90	10	727 910 376	0.235	81	46

27 96 01

PROGEF Standard end cap

Model:

- Material: PP-H
- * use pipe SDR 7.4



d [mm]	PN	Code	kg	D [mm]	L [mm]
* 16	10	727 960 105	0.006	25	20
20	10	727 960 106	0.009	30	27
25	10	727 960 107	0.015	36	30
32	10	727 960 108	0.023	44	34
40	10	727 960 109	0.035	53	38
50	10	727 960 110	0.061	65	44
63	10	727 960 111	0.102	80	51
75	10	727 960 112	0.149	91	65
90	10	727 960 113	0.277	111	77
110	10	727 960 114	0.411	137	93

27 90 00

PROGEF Standard stiffener

Model:

- Material: PP-H
- Used as support during d20 and d25 socket fusion jointing to prevent the pipe from collapsing during the heating and jointing process.



d [mm]	e [mm]	Code	kg	L [mm]	d1 [mm]	d2 [mm]
20	1,9	727 900 006	0.001	10	14	18
25	2,3	727 900 007	0.004	11	18	23

Adaptor fittings for socket fusion

27 10 02

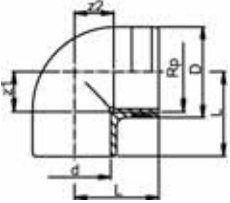

PROGEF Standard elbow 90° metric Rp

Model:

- Material: PP-H
- With fusion socket metric and parallel female thread Rp, reinforced
- Reinforcing ring stainless (A2)
- Connection to plastic or metal threads
- Do not use thread sealing pastes that are harmful to PP
- Install with low mechanical stress and avoid large cyclic temperature changes

d [mm]	Rp [inch]	PN	Code	kg	D [mm]	L [mm]	z1 [mm]	z2 [mm]
20	½	10	727 100 206	0.022	30	28	14	14
25	¾	10	727 100 207	0.035	35	32	16	16
32	1	10	727 100 208	0.057	44	38	20	20
40	1 ¼	10	727 100 209	0.087	54	44	24	24

27 20 02

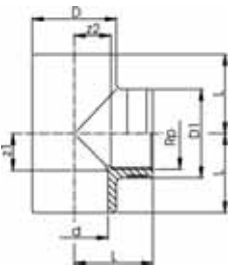

PROGEF Standard tee 90° metric Rp

Model:

- Material: PP-H
- Line, with fusion socket metric
- Branch, with BSP parallel female thread Rp, reinforced
- Reinforcing ring stainless (A2)
- Connection to plastic or metal threads
- Do not use thread sealing pastes that are harmful to PP
- Install with low mechanical stress and avoid large cyclic temperature changes

d [mm]	Rp [inch]	PN	Code	kg	D [mm]	D1 [mm]	L [mm]	z1 [mm]	z2 [mm]
20	½	10	727 200 206	0.030	31	30	28	14	14
25	¾	10	727 200 207	0.042	36	35	32	16	16
32	1	10	727 200 208	0.071	44	45	38	20	20
40	1 ¼	10	727 200 209	0.107	54	55	44	24	24

27 91 30

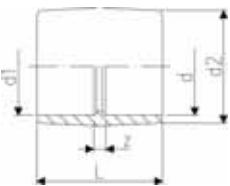

PROGEF Standard adaptor socket Metric Inch BS

Model:

- Material: PP-H
- With fusion socket metric and BS Inch (ASTM)

d [mm]	d1 [inch]	PN	Code	kg	d2 [mm]	L [mm]	z [mm]
20	½	10	727 913 006	0.014	31	35	7
25	¾	10	727 913 007	0.019	36	39	7
32	1	10	727 913 008	0.025	44	43	7
40	1 ¼	10	727 913 009	0.040	54	48	8
50	1 ½	10	727 913 010	0.100	66	54	8
63	2	10	727 913 011	0.130	82	62	8
90	3	10	727 913 013	0.260	112	81	10
110	4	10	727 913 014	0.389	134	96	12

27 91 02

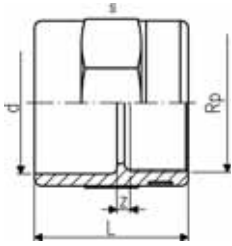

PROGEF Standard adaptor socket metric Rp

Model:

- Material: PP-H
- With fusion socket metric and parallel female thread Rp, reinforced
- Reinforcing ring stainless (A2)
- Connection to plastic or metal threads
- Do not use thread sealing pastes that are harmful to PP
- Install with low mechanical stress and avoid large cyclic temperature changes

d [mm]	Rp [inch]	PN	Code	kg	L [mm]	s [mm]	z [mm]
20	3/8	10	727 910 205	0.017	35	32	7
20	1/2	10	727 910 206	0.018	40	32	7
25	3/4	10	727 910 207	0.025	42	36	7
32	1	10	727 910 208	0.040	48	46	7
40	1 1/4	10	727 910 209	0.064	53	55	7
50	1 1/2	10	727 910 210	0.089	54	65	9
63	2	10	727 910 211	0.144	62	80	9

27 91 42



Adaptor Sockets, PP-H metric - NPT

Model:

- Material: PP-H
- With fusion socket metric and NPT tapered female thread, reinforced
- Reinforcing ring stainless (A2)
- Connection to plastic or metal threads
- Do not use thread sealing pastes that are harmful to PP
- Install with low mechanical stress and avoid large cyclic temperature changes

d [mm]	NPT [inch]	PN	Code	kg	L [mm]	s [mm]	z [mm]
20	1/2	10	727 914 266	0.018	40	32	7
25	3/4	10	727 914 267	0.023	42	36	7
32	1	10	727 914 268	0.039	48	46	7
40	1 1/4	10	727 914 269	0.056	53	55	7
50	1 1/2	10	727 914 270	0.095	54	65	9
63	2	10	727 914 271	0.145	62	80	9

27 91 05

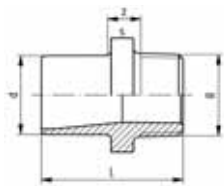

PROGEF Standard adaptor nipple metric R

Model:

- Material: PP-H
- With fusion spigot metric and R tapered male thread
- Connection to plastic threads only
- Do not use thread sealing pastes that are harmful to PP
- Install with low mechanical stress and avoid large cyclic temperature changes

d [mm]	R [inch]	PN	Code	kg	L [mm]	s [mm]	z [mm]
16	3/8	10	727 910 505	0.008	37	27	13
20	1/2	10	727 910 506	0.011	42	32	13
25	3/4	10	727 910 507	0.015	46	36	13
32	1	10	727 910 508	0.027	52	46	12
40	1 1/4	10	727 910 509	0.040	56	55	14
50	1 1/2	10	727 910 510	0.061	60	65	15
63	2	10	727 910 511	0.100	69	80	16

27 91 45

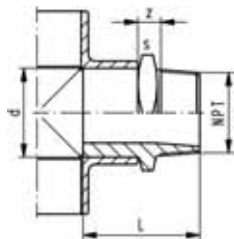

PROGEF Standard adaptor nipple metric NPT

Model:

- Material: PP-H
- With fusion spigot metric and NPT tapered male thread
- Connection to plastic threads only
- Do not use thread sealing pastes that are harmful to PP
- Install with low mechanical stress and avoid large cyclic temperature changes

d [mm]	NPT [inch]	PN	Code	kg	s [mm]	L [mm]	z [mm]
16	3/8	10	727 914 555	0.008	27	37	13
20	1/2	10	727 914 556	0.013	32	42	13
25	3/4	10	727 914 557	0.015	36	46	13
32	1	10	727 914 558	0.026	46	52	12
40	1 1/4	10	727 914 559	0.041	55	56	14
50	1 1/2	10	727 914 560	0.061	65	60	15
63	2	10	727 914 561	0.185	80	69	16

27 91 04

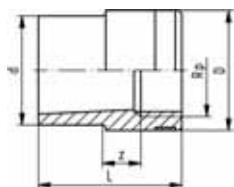

PROGEF Standard reducing bush metric Rp

Model:

- Material: PP-H
- With fusion spigot metric and BSP parallel female thread, reinforced
- Reinforcing ring stainless (A2)
- Connection to plastic or metal threads
- Do not use thread sealing pastes that are harmful to PP
- Install with low mechanical stress and avoid large cyclic temperature changes

d [mm]	Rp [inch]	PN	Code	kg	L [mm]	z [mm]
20	1/4	10	727 910 433	0.011	36	7
20	3/8	10	727 910 434	0.011	36	7
25	1/2	10	727 910 437	0.015	45	6
32	3/4	10	727 910 441	0.022	47	8
40	1	10	727 910 446	0.039	53	9
50	1 1/4	10	727 910 452	0.061	55	10

27 96 04

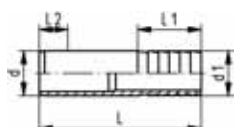

PROGEF Standard hose connector metric

Model:

- Material: PP-H
- With socket fusion spigot metric and parallel hose connection

d [mm]	d1 [mm]	PN	Code	kg	L [mm]	L1 [mm]	L2 [mm]
20	20	10	727 960 406	0.008	78	27	14
25	25	10	727 960 407	0.014	91	36	16
32	32	10	727 960 408	0.025	100	36	18
40	40	10	727 960 409	0.038	104	42	20
50	50	10	727 960 410	0.061	90	48	23
63	60	10	727 960 411	0.084	100	50	27

27 31 00

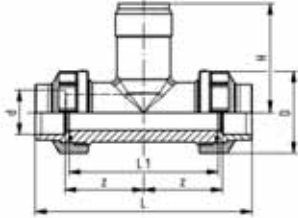

PROGEF Standard installation fitting type 310 S5/SDR11 for socket systems metric

Model:

- Material: PP-H
- Threaded outlet 1 ¼" NPSM
- Union end with fusion socket PP-H

Range of use:

- compatible signet flow sensors: type 2551, 2537, 515, 8510, 2536, 8512
- compatible signet pH/ORP sensors: type 2724, 2725, 2726

Attention:

- sensor length depends on installation fitting

d [mm]	DN [mm]	PN	EPDM Code	FPM Code	kg
20	15	10	727 310 006	727 310 036	0.136
25	20	10	727 310 007	727 310 037	0.190
32	25	10	727 310 008	727 310 038	0.250
40	32	10	727 310 009	727 310 039	0.356
50	40	10	727 310 010	727 310 040	0.510
63	50	10	727 310 011	727 310 041	0.645

d [mm]	D [mm]	z [mm]	L [mm]	L1 [mm]	H [mm]	Sensor Type
20	48	50	128	90	76	flow X0, pH XX
25	58	55	142	100	78	flow X0, pH XX
32	65	60	156	110	81	flow X0, pH XX
40	79	60	160	110	85	flow X0, pH XX
50	91	65	176	120	89	flow X0, pH XX
63	105	70	194	130	95	flow X0, pH XX

27 31 20

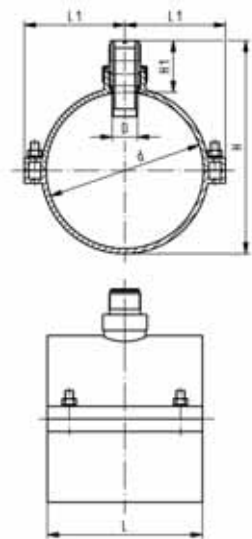

PROGEF Standard installation fitting type 312 metric

Model:

- Material: PP-H
- Threaded outlet 1 ¼" NPSM
- Top saddle with EPDM gasket
- Stainless steel bolts and nuts

Range of use:

- compatible signet flow sensors: type 2551, 2537, 515, 8510, 2536, 8512

Attention:

- sensor length depends on installation fitting
- working temperature max. +40°C (water)

d [mm]	DN [mm]	PN	Code	kg	D [mm]	L [mm]	L1 [mm]	H [mm]	H1 [mm]	Sensor Type
75	65	8	727 312 072	0.488	34	78	62	172	88	flow X1
90	80	8	727 312 073	0.514	34	86	69	186	87	flow X1
110	100	8	727 312 074	0.602	34	98	79	206	86	flow X1

Unions for socket fusion

EPDM 27 51 01
FPM 27 52 01

PROGEF Standard union metric

Model:

- Material: PP-H
- Fusion socket metric
- D75-110 with new thread geometry, now rated PN10 up to d110
- Jointing face: With O-ring groove
- For the dimensions d75-110 please see instructions for the installation



d [mm]	PN	EPDM Code	FPM Code	kg	D [mm]	G [inch]	L1 [mm]	L2 [mm]	z [mm]	z1 [mm]
16	10	727 510 155	727 520 155	0.020	35	3/4	18	24	5	11
20	10	727 510 156	727 520 156	0.038	48	1	19	26	5	12
25	10	727 510 157	727 520 157	0.062	58	1 1/4	21	28	5	12
32	10	727 510 158	727 520 158	0.080	65	1 1/2	23	30	5	12
40	10	727 510 159	727 520 159	0.137	79	2	25	34	5	14
50	10	727 510 160	727 520 160	0.136	91	2 1/4	28	39	5	16
63	10	727 510 161	727 520 161	0.251	111	2 3/4	32	47	5	20
75	10	727 510 172	727 520 172	0.432	135	S107,5x3,6	36	51	5	20
90	10	727 510 173	727 520 173	0.625	158	S127,5x3,6	42	55	7	20
110	10	727 510 174	727 520 174	1.009	188	S152,5x3,6	49	54	7	12

27 51 30

PROGEF Standard adapter union metric BS Inch / ASTM

Model:

- Material: PP-H
- Fusion socket metric
- Jointing face: With O-ring groove



d [mm]	d2	PN	Code	kg	D [mm]	G [inch]	L1 [mm]	L2 [mm]	z1 [mm]	z2 [mm]
20	1/2	10	727 513 006	0.041	48	1	19	26	5	12
25	3/4	10	727 513 007	0.061	58	1 1/4	21	28	5	12
32	1	10	727 513 008	0.028	65	1 1/2	23	30	5	12
40	1 1/4	10	727 513 009	0.108	79	2	25	34	5	14
50	1 1/2	10	727 513 010	0.133	91	2 1/4	28	39	5	16
63	2	10	727 513 011	0.252	111	2 3/4	32	47	5	20

67 05 02

PROGEF Standard tank adaptor

Model:

- Material: PP-H
- End connection: Union with fusion socket metric
- Gasket: flat gasket EPDM

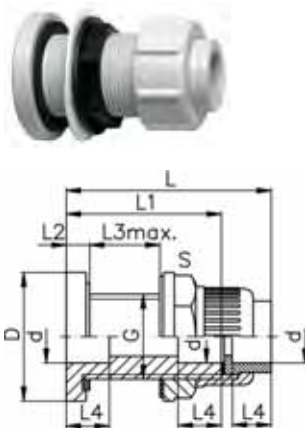

d [mm]	Code	kg	G [inch]	D [mm]	L [mm]	L1 [mm]	L2 [mm]	L3 max [mm]	L4 [mm]	s [mm]	Diameter of bore in tank side [mm]
20	167 050 226	0.098	1	56	89	67	11	30	16	38	35
25	167 050 227	0.153	1 1/4	65	96	72	12	32	18	47	43
32	167 050 228	0.185	1 1/2	70	100	75	12	33	20	53	49
40	167 050 229	0.292	2	95	106	78	12	32	22	75	61
50	167 050 230	0.308	2 1/4	95	112	82	13	32	25	75	67
63	167 050 231	0.493	2 3/4	115	112	87	13	33	29	101	83

Instructions for the installation of unions in PP, PE d 75, d 90 and d 110

The newest generation of plastic unions in the above materials and dimensions has been fitted with a state-of-the-art, plastics-oriented buttress thread. You therefore have a product in which the nominal pressure and the safety reserve have been dramatically increased. Also new are the butt fusion versions. In this connection, there are a few points which you must be aware of.

Caution

- ① The threads of the union nut and bush have been reworked for PP, PVDF and PE! When using individual parts, please check prior to installation if the threads of the union bush and the union nut coincide.



Union bush with trapezoid thread on union nut with trapezoid thread
or
Union bush with buttress thread on union nut with buttress thread

Tip

To make installation of the union easier, wet the union nut.

- ② For the dimensions d90 and d110 we advise fusing the complete union, if possible (or slide the union nut to the collar of the union end) because after fusion the union nut cannot be slid over the fusion bead. (Fig. 1)
- ③ For design reasons, it is theoretically possible to combine different nominal diameters of union ends and nuts. To make sure combinations are technically correct, you can find the code numbers of the single parts and spare parts for each union in the Tables 1-3.

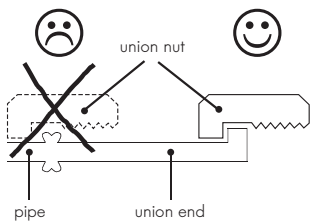

Fig. 1

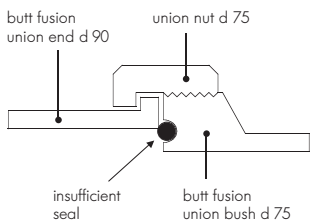

Fig. 2

Caution

Only use union bushes and union ends with the same nominal diameter!

A butt fusion union bush d 75 may not be combined with a butt fusion union end d 90 to form a reducer because this can cause leakage, as illustrated to the left. (Fig. 2)

Markings on the union nuts

SF/MS = socket fusion, BF/ST = butt fusion

SF/MS 75 specified for socket fusion d 75
BF/ST 75-90 specified for butt fusion d 75-75 and d 90-90

SF/MS 90 specified socket fusion d 90
BF/ST 110 specified butt fusion d 110

110 specified for socket fusion d 110

Tip

We recommend changing materials only for the union end for installation reasons.

Selection tables for single parts and spare parts



Butt fusion

Socket fusion

Table 1

Single parts for **PP-H** unions d 75, d 90 and d 110

d	BF/ST	SF/MS	SDR	PN	Code union end	Code union bush	Code union nut*
75			11	10	727 608 512	727 648 512	727 690 422
			17.6	6	727 608 412	727 648 412	727 690 422
			—	10	727 600 112	727 640 172	727 690 422
90			11	10	727 608 513	727 648 513	727 690 422
			17.6	6	727 608 413	727 648 413	727 690 422
			—	10	727 600 113	727 640 173	727 690 423
110			11	10	727 608 514	727 648 514	727 690 423
			17.6	6	727 608 414	727 648 414	727 690 423
			—	10	727 600 114	727 640 174	727 690 424

Table 2

Single parts for **PE 100** unions d 75, d 90 and d 110

d	BF/ST	SF/MS	SDR	PN	Code union end	Code union bush	Code union nut*
75			11	10	753 608 612	753 648 612	727 690 442
			17.6	10	753 608 412	753 648 412	727 690 442
90			11	10	753 608 613	753 648 613	727 690 442
			17.6	10	753 608 413	753 648 413	727 690 442
110			11	10	753 608 614	753 648 614	727 690 443
			17.6	10	753 608 414	753 648 414	727 690 443

Table 3

O-Rings for PP-H, PE 100

d	BF/ST	SF/MS	SDR	PN	Code O-Ring EPDM ¹	Code O-Ring FPM ¹
75				16	748 410 013	749 410 013
				16	748 410 014	749 410 014
90				16	748 410 014	749 410 014
				16	748 410 015	749 410 015
110				16	748 410 015	749 410 015
				16	748 410 016	749 410 016

* Union nuts overlap several dimensions

¹ Flange adaptor O-rings, one size smaller in nominal dimensions, are used for the d 75–110 butt-fusion unions

Adaptor Unions for Socket Fusion

27 53 03



PROGEF Standard adaptor union PP-H/malleable iron galvanised Metric Rp

Model:

- Union End: malleable iron with parallel female thread Rp
- Union Bush: fusion socket PP-H metric
- Union Nut: PP-H
- Gasket: O-Ring EPDM No. 48 41 00

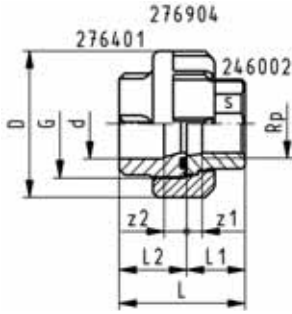

d [mm]	Rp [inch]	PN	Code	kg	D [mm]	L [mm]	L1 [mm]	L2 [mm]	z1 [mm]	z2 [mm]	G [inch]	s [mm]
20	1/2	10	727 530 306	0.073	43	48	22	26	9	10	1	25
25	3/4	10	727 530 307	0.118	51	50	22	28	7	10	1 1/4	31
32	1	10	727 530 308	0.199	58	56	26	30	9	10	1 1/2	38
40	1 1/4	10	727 530 309	0.276	72	65	31	34	12	12	2	48
50	1 1/2	10	727 530 310	0.317	83	72	33	39	14	14	2 1/4	54
63	2	10	727 530 311	0.579	100	82	35	47	11	18	2 3/4	67

27 53 08



PROGEF Standard adaptor union PP-H/malleable iron galvanised Metric R

Model:

- Union End: Malleable iron with taper male thread R
- Union Bush: fusion socket PP-H metric
- Union Nut: PP-H
- Gasket: O-Ring EPDM No. 48 41 00

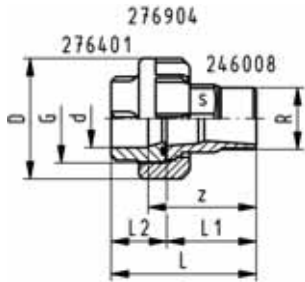

d [mm]	R [inch]	PN	Code	kg	D [mm]	L [mm]	L1 [mm]	L2 [mm]	z [mm]	G [inch]	s [mm]
20	1/2	10	727 530 806	0.112	43	66	40	26	50	1	25
25	3/4	10	727 530 807	0.171	51	71	43	28	53	1 1/4	31
32	1	10	727 530 808	0.236	58	78	48	30	58	1 1/2	38
40	1 1/4	10	727 530 809	0.379	72	91	57	34	69	2	48
50	1 1/2	10	727 530 810	0.512	83	98	59	39	73	2 1/4	54
63	2	10	727 530 811	0.763	100	109	62	47	80	2 3/4	67

34 60 01



Union Ends, PE80

Model:

- With fusion socket metric
- Suitable for unions, tank connectors and diaphragm valves Type 514

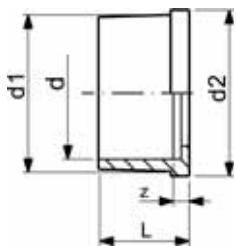

d [mm]	PN	Code	kg	d1 [mm]	d2 [mm]	L [mm]	L1 [mm]	z [mm]
20	10	734 600 106	0.006	28	30	19	5	5
25	10	734 600 107	0.013	36	39	21	5	5
32	10	734 600 108	0.015	42	45	23	6	5
40	10	734 600 109	0.026	53	57	25	6	5
50	10	734 600 110	0.025	59	63	28	7	5
63	10	734 600 111	0.044	74	79	32	8	5

24 60 08

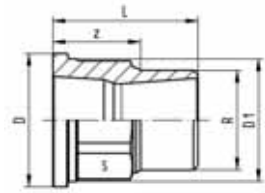

Union end malleable iron galvanized R

Model:

- Union End: Malleable iron with taper male thread R

d [mm]	R [inch]	Code	kg	D [mm]	D1 [mm]	L [mm]	z [mm]	s [mm]
20	½	724 600 806	0.069	30	27	40	25	23
25	¾	724 600 807	0.115	39	36	43	27	30
32	1	724 600 808	0.161	44	41	48	29	36
40	1 ¼	724 600 809	0.294	56	52	57	36	48
50	1 ½	724 600 810	0.353	62	58	59	37	54
63	2	724 600 811	0.570	78	73	62	36	66

24 60 02

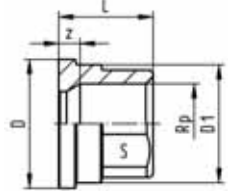

Union end malleable iron galvanized Rp

Model:

- Union End: malleable iron with parallel female thread Rp

d [mm]	Rp [inch]	PN	Code	kg	D [mm]	D1 [mm]	L [mm]	z [mm]	s [mm]
20	½	16	724 600 206	0.037	30	27	22	9	25
25	¾	16	724 600 207	0.072	39	36	22	7	31
32	1	16	724 600 208	0.088	44	41	26	9	38
40	1 ¼	16	724 600 209	0.172	56	52	31	12	48
50	1 ½	16	724 600 210	0.210	62	58	33	14	54
63	2	16	724 600 211	0.331	78	73	35	11	67

20 60 02

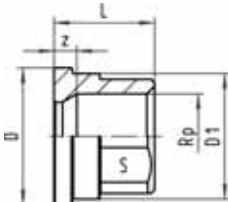

Union end brass Rp

Model:

- Union End: Brass with parallel female thread Rp

d [mm]	Rp [inch]	Code	kg	D [mm]	D1 [mm]	z [mm]	L [mm]	s [mm]
20	½	720 600 236	0.059	30	28	5	22	25
25	¾	720 600 237	0.100	39	36	6	25	30
32	1	720 600 238	0.128	45	42	6	27	36
40	1 ¼	720 600 239	0.211	56	53	7	31	46
50	1 ½	720 600 240	0.324	62	59	7	35	55
63	2	720 600 241	0.510	78	74	8	40	65
75	2 ½	720 600 242	0.893	100	92	10	47	85
90	3	720 600 243	1.395	121	110	11	52	95

20 60 02

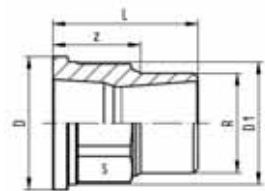

Union end brass R

Model:

- Union End: Brass with taper male thread R

d [mm]	R [inch]	Code	kg	D [mm]	D1 [mm]	L [mm]	z [mm]	s [mm]
20	½	720 600 246	0.092	30	28	37	22	25
25	¾	720 600 247	0.151	39	36	42	25	30
32	1	720 600 248	0.216	45	42	46	28	36
40	1 ¼	720 600 249	0.408	56	53	52	32	46
50	1 ½	720 600 250	0.538	62	59	56	36	55
63	2	720 600 251	0.859	78	74	67	42	65
75	2 ½	720 600 252	1.446	100	92	77	49	85
90	3	720 600 253	2.063	121	110	86	54	95

27 69 04

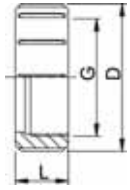

Union Nut, PP-GF

Model:

- Material: PP glass-fibre reinforced

Socket Fusion d [mm]	Butt Fusion d [mm]	PN	G [inch]	Code	kg	D [mm]	L [mm]
16	16	10	3/4	727 890 405	0.007	35	21
20	20	10	1	727 890 406	0.023	48	24
25	25	10	1 1/4	727 890 407	0.035	58	26
32	32	10	1 1/2	727 890 408	0.044	65	28
40	40	10	2	727 890 409	0.044	77	27
50	50	10	2 1/4	727 890 410	0.062	84	30
63	63	10	2 3/4	727 890 411	0.119	111	39
75	75 - 90	10	S107,5x3,6	727 890 422	0.205	135	40
90	110	10	S127,5x3,6	727 890 423	0.730	158	43
110	-	10	S152,5x3,6	727 890 424	0.499	188	48

EPDM 48 41 00
FPM 49 41 00

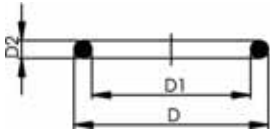

O-Ring gasket

Model:

- For unions and adaptor unions
- Hardness approx. 65° Shore
- EPDM minimum temperature -40°C
- FPM minimum temperature -15°C

* for unions PVC-U, PVC-C and ABS: 21 51 01, 21 51 11, 21 53 03, 21 53 08, 21 55 04, 21 55 13, 21 55 18, 23 51 01 and 29 51 01 only

d [mm]	DN [mm]	EPDM Code	FPM Code	kg	D [mm]	D1 [mm]	D2 [mm]
16	10	748 410 005	749 410 005	0.001	21	16	2.62
20	15	748 410 006	749 410 006	0.001	27	20	3.53
25	20	748 410 007	749 410 007	0.002	35	28	3.53
32	25	748 410 008	749 410 008	0.002	40	33	3.53
40	32	748 410 009	749 410 009	0.007	51	41	5.34
50	40	748 410 010	749 410 010	0.060	58	47	5.34
63	50	748 410 011	749 410 011	0.003	70	60	5.34
75	65	748 410 014	749 410 014	0.012	93	82	5.34
90	80	748 410 015	749 410 015	0.015	112	101	5.34
110	100	748 410 016	749 410 016	0.031	134	120	6.99

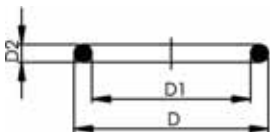

O-Ring Gaskets

Model:

- For unions and adaptor unions
- Hardness approx. 75° Shore
- FFPM minimum temperature -20°C

d [mm]	DN [mm]	FFPM Code	kg	D [mm]	D1 [mm]	D2 [mm]
20	15	700 245 481	0.002	27	20	4
25	20	700 245 482	0.002	35	28	4
32	25	700 245 483	0.002	40	33	4
40	32	700 245 484	0.006	51	41	5
50	40	700 245 485	0.007	58	47	5
63	50	700 245 486	0.010	70	60	5

Flange Adaptors, Flanges and Gaskets for Socket Fusion

27 79 02

PROGEF Standard flange adaptor Joining face flat/serrated



Model:

- Material: PP-H
- Counterpart: Flange Adaptor flat/serrated or with O-ring groove
- Connection: according to EN ISO 15494-1
- Gasket: Profile flange gasket EPDM No. 48 44 07, FPM No. 49 44 07
- Flanges: PP with steel core, No. 27 70 02, PP-V, No. 27 70 04



d [mm]	DN [mm]	PN	Code	kg	D [mm]	D1 [mm]	L [mm]	L1 [mm]	z [mm]
20	15	10	727 790 206	0.011	27	45	19	7	5
25	20	10	727 790 207	0.022	33	58	21	9	5
32	25	10	727 790 208	0.033	41	68	23	10	5
40	32	10	727 790 209	0.046	50	78	25	11	5
50	40	10	727 790 210	0.060	61	88	28	12	5
63	50	10	727 790 211	0.090	76	102	32	14	5
75	65	10	727 790 212	0.155	90	122	36	16	5
90	80	10	727 790 213	0.204	108	138	42	17	7
110	100	10	727 790 214	0.286	131	158	48	18	7

27 79 02

PROGEF Standard flange adaptor Joining face serrated ANSI



Model:

- Material: PP-H
- Counterpart: Flange adaptor serrated
- Gasket: Profile flange gasket EPDM No. 48 44 05, FPM No. 49 44 05
- Flanges: PP with steel core, No. 27 70 02, PP-V, No 27 70 04

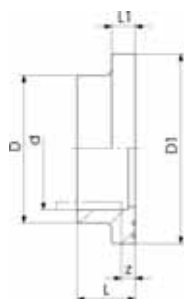

d [mm]	PN	Code	kg	D [mm]	D1 [mm]	L [mm]	L1 [mm]	z [mm]
25	10	727 790 257	0.018	33	54	21	7	5
32	10	727 790 258	0.026	41	63	23	7	5
40	10	727 790 259	0.041	50	73	25	8	5
50	10	727 790 260	0.055	61	82	28	8	5
90	10	727 790 263	0.189	108	133	36	16	5

27 81 01

PROGEF Standard flange adaptor Jointing face with o-ring groove

Model:

- Material: PP-H
- Counterpart: Flange adaptor flat/serrated, No. 27 79 02
- Gasket: O-ring EPDM No. 48 41 01, FPM No. 49 41 01
- Flanges: PP with steel core, No. 27 70 02 (mm) or No. 27 70 12 (ANSI), PP-V, No. 27 70 04

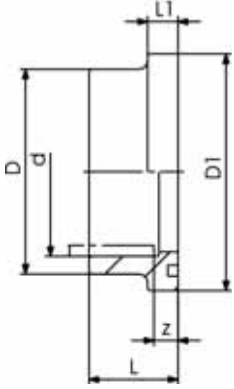

d [mm]	DN [mm]	PN	Code	kg	D [mm]	D1 [mm]	L [mm]	L1 [mm]	z [mm]
20	15	10	727 810 106	0.007	27	34	22	9	8
25	20	10	727 810 107	0.012	33	41	24	10	8
32	25	10	727 810 108	0.018	41	50	26	10	8
40	32	10	727 810 109	0.027	50	61	30	13	10
50	40	10	727 810 110	0.043	61	73	33	13	10
63	50	10	727 810 111	0.070	76	90	37	14	10
75	65	10	727 810 112	0.105	90	106	40	15	10
90	80	10	727 810 113	0.170	108	125	47	16	12
110	100	10	727 810 114	0.263	131	150	55	18	13

27 80 00

PROGEF Standard outlet flange adaptor Jointing face flat

Model:

- Material: PP-H
- With fusion socket metric
- Suitable for wafer check valves Type 369
- To be installed on the outlet side of the valve
- Use flanges PP-V 27 70 04

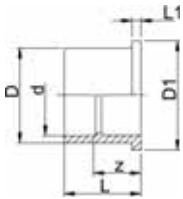

d [mm]	DN [mm]	PN	Code	kg	D [mm]	D1 [mm]	L [mm]	L1 [mm]	z [mm]
40	32	6	727 800 009	0.068	50	78	55	11	35
50	40	6	727 800 010	0.087	61	88	61	12	38
63	50	6	727 800 011	0.136	76	102	69	14	41
75	65	6	727 800 012	0.214	90	122	79	16	49
90	80	6	727 800 013	0.350	107	138	100	17	65
110	100	6	727 800 014	0.468	130	158	105	18	62

27 70 04
27 70 05

Backing Flanges, PP-V For socket systems metric

Model:

- Modern full-plastic flange PP-GF (30 % glass-fibre reinforced)
- With V-groove which applies force evenly on collar
- With integrated bolt retainers as an assembly aid
- UV-resistant. Applicable for outside applications
- Connecting dimension: ISO 7005, EN 1092, BS 4504, DIN 2501
- **Bolt circle PN 10**

* Combined version, metric-ANSI

AL: number of holes

1) Suitable for socket- and butt fusion systems (no pictograph on flange)

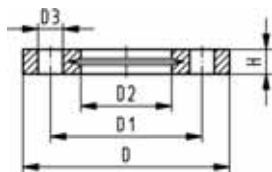

d [mm]	DN [mm]	PN	Code	kg	D [mm]	D1 [mm]	D2 [mm]	D3 [mm]	H [mm]	AL	SC
1) 20	15	16	727 700 406	0.093	95	65.0	28	14	16	4	M12
1) 25	20	16	727 700 407	0.120	105	75.0	34	14	17	4	M12
1) 32	25	16	727 700 408	0.151	115	85.0	42	14	18	4	M12
1) 40	32	16	727 700 409	0.244	140	100.0	51	18	20	4	M16
1) 50	40	16	727 700 410	0.297	150	110.0	62	18	22	4	M16
1) 63	50	16	727 700 411	0.362	165	125.0	78	18	24	4	M16
1) 75	65	16	727 700 412	0.487	185	145.0	92	18	26	4	M16
90	80	16	727 700 413	0.550	200	160.0	110	18	27	8	M16
110	100	16	727 700 414	0.640	220	180.0	133	18	28	8	M16

27 70 14
27 70 15

Backing Flanges, PP-V For socket systems Inch ANSI

Model:

- Modern full-plastic flange PP-GF (30 % glass-fibre reinforced)
- With V-groove which applies force evenly on collar
- With integrated bolt-fixing as an assembly aid
- UV-resistant. Applicable for outside applications
- Connecting dimension: ANSI/ASME B 16.5 class 150, ASTM D 4024, BS 1560, BS EN 1759
- **Bolt circle class 150**
- 727701414, 727700417, 727700419: only for use with original metric flange adaptors

1) Suitable for socket- and butt fusion systems (no pictograph on flange)

AL: number of holes

* Combined version, metric-ANSI

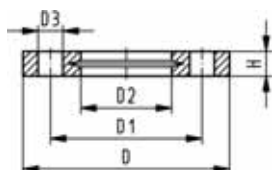

Inch	DN [mm]	d [mm]	PN	Code	kg	D [mm]	D1 [mm]	D2 [mm]	D3 [mm]	H [mm]	AL	SC
1/2	15	20	16	727 701 406	0.091	95	60.0	28	16	16	4	M12
3/4	20	25	16	727 701 407	0.120	105	70.0	34	16	17	4	M12
1	25	32	16	727 701 408	0.147	115	79.0	42	16	18	4	M12
1 1/4	32	40	16	727 701 409	0.246	140	89.0	51	16	20	4	M16
1 1/2	40	50	16	727 701 410	0.299	150	98.0	62	16	22	4	M16
2	50	63	16	727 701 411	0.361	165	121.0	78	19	24	4	M16
2 1/2	65	75	16	727 701 412	0.492	185	140.0	92	19	26	4	M16
3	80	90	16	727 701 413	0.605	200	152.0	110	19	27	4	M16
4	100	110	16	727 701 414	0.704	229	190.0	133	19	28	8	M16

27 70 02

Backing Flanges, PP/Steel For socket systems metric

Model:

- PP-GF (30% glass-fibre reinforced) with steel ring
- UV-resistant. Applicable for outside applications
- Connecting dimension: ISO 7005, EN 1092, BS 4504, DIN 2501
- **Bolt circle PN 10**

¹ Connecting dimension: ISO 2536, bolt circle acc. DN125, suitable for flange adaptor d125/DN100

² Connecting dimension: ISO 2536, bolt circle acc. DN225, suitable for flange adaptor d250/DN250

AL: number of holes

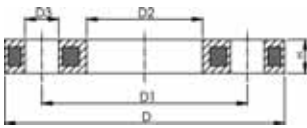

d [mm]	DN [mm]	PN	Code	kg	D [mm]	D1 [mm]	D2 [mm]	D3 [mm]	H [mm]	AL	SC
20	15	16	727 700 206	0.216	95	65	28	14	12	4	M12
25	20	16	727 700 207	0.279	105	75	34	14	12	4	M12
32	25	16	727 700 208	0.429	115	85	42	14	16	4	M12
40	32	16	727 700 209	0.621	140	100	51	18	16	4	M16
50	40	16	727 700 210	0.722	150	110	62	18	20	4	M16
63	50	16	727 700 211	1.084	165	125	78	18	20	4	M16
75	65	16	727 700 212	1.349	185	145	92	18	20	4	M16
90	80	16	727 700 213	1.369	200	160	110	18	20	8	M16
110	100	16	727 700 214	1.522	220	180	133	18	20	8	M16

27 70 12

Backing Flanges, PP/Steel For socket systems Inch/ANSI

Model:

- For Flange Adaptors BS/ANSI
- Material: PP (30 % glass-fibre reinforced) with steel ring
- UV-resistant. Applicable for outside applications
- Connecting dimension: ANSI/ASME B 16.5 class 150, ASTM D 4024, BS 1560, BS EN 1759
- **Bolt circle class 150**
- 727701214, 727700217: only for use with original metric flange adaptors

AL: number of holes

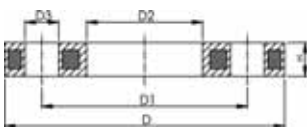

d [inch]	DN [mm]	d [mm]	PN	Code	kg	D1 [mm]	D2 [mm]	D3 [mm]	D [mm]	H [mm]	AL	SC
½	15	20	16	727 701 206	0.213	60	28	16	95	12	4	M12
¾	20	25	16	727 701 207	0.260	70	34	16	105	12	4	M12
1	25	32	16	727 701 208	0.416	79	42	16	115	16	4	M12
1 ¼	32	40	16	727 701 209	0.730	89	51	16	140	16	4	M16
1 ½	40	50	16	727 701 210	0.809	98	62	16	150	18	4	M16
2	50	63	16	727 701 211	0.866	121	78	19	165	18	4	M16
2 ½	65	75	16	727 701 212	1.117	140	92	19	185	18	4	M16
3	80	90	16	727 701 213	1.492	152	110	19	200	20	4	M16
4	100	110	16	727 701 214	1.695	190	133	19	229	20	8	M16

27 30 10
27 40 10

Fixed Flanges, PP-H metric Jointing face flat

Model:

- Material: PP-H
- With fusion socket metric
- Connecting dimension: ISO 7005 PN 10, EN 1092 PN 10, DIN 2501 PN 10, BS 4504 PN 10

AL: number of holes

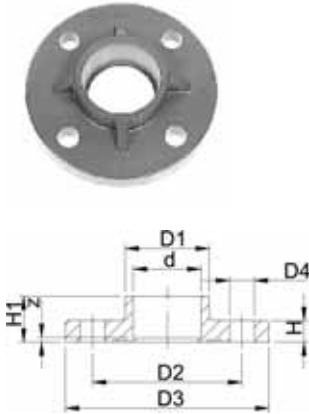

d [mm]	DN [mm]	Inch	PN	Code	kg	D1 [mm]	D2 [mm]	D3 [mm]	D4 [mm]	H [mm]	H1 [mm]	AL	z [mm]
20	15	1/2	10	727 730 106	0.069	27	65	94	14	12	19	4	5
25	20	3/4	10	727 730 107	0.094	33	75	103	14	13	21	4	5
32	25	1	10	727 730 108	0.129	40	85	115	14	14	23	4	5
40	32	1 1/4	10	727 730 109	0.203	50	100	138	18	15	25	4	5
50	40	1 1/2	10	727 730 110	0.246	61	110	148	18	16	27	4	5
63	50	2	10	727 730 111	0.330	76	125	163	18	18	31	4	5

27 30 10
27 40 10

Fixed Flanges, PP-H metric Combined jointing face: flat and serrated

Model:

- Material: PP-H
- With fusion socket metric
- Connecting dimension: ISO 7005 PN 10, EN 1092 PN 10, DIN 2501 PN 10, BS 4504 PN 10

AL: number of holes

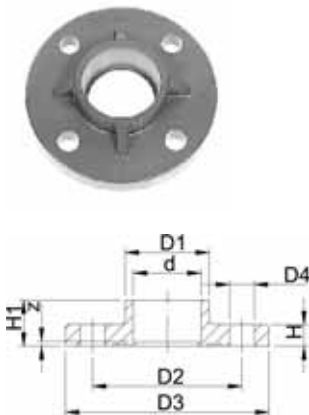

d [mm]	DN [mm]	Inch	PN	Code	kg	D1 [mm]	D2 [mm]	D3 [mm]	D4 [mm]	H [mm]	H1 [mm]	AL	z [mm]
20	15	1/2	10	727 740 106	0.065	27	65	94	14	12	19	4	5
25	20	3/4	10	727 740 107	0.074	33	75	103	14	13	21	4	5
32	25	1	10	727 740 108	0.115	40	85	115	14	14	23	4	5
40	32	1 1/4	10	727 740 109	0.175	50	100	138	18	15	25	4	5
50	40	1 1/2	10	727 740 110	0.210	61	110	148	18	16	27	4	5
63	50	2	10	727 740 111	0.286	76	125	163	18	18	31	4	5

EPDM 48 41 01
FPM 49 41 01

O-Ring gasket





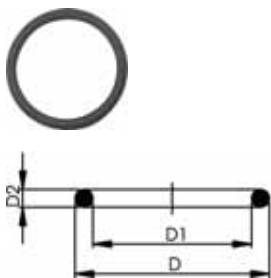







Model:









- For Flange Adaptors
- Hardness approx. 65° Shore



d [mm]	DN [mm]	EPDM Code	FPM Code	kg	D [mm]	D1 [mm]	D2 [mm]
20	15	748 410 001	749 410 001	0.002	31	23	3.53
25	20	748 410 007	749 410 007	0.002	35	28	3.53
32	25	748 410 002	749 410 002	0.003	43	36	3.53
40	32	748 410 003	749 410 003	0.001	55	44	5.34
50	40	748 410 012	749 410 012	0.008	64	53	5.34
63	50	748 410 013	749 410 013	0.011	80	69	5.34
75	65	748 410 014	749 410 014	0.012	93	82	5.34
90	80	748 410 015	749 410 015	0.015	112	101	5.34
110	100	748 410 016	749 410 016	0.031	134	120	6.99

PROGEF Standard Hand-Operated and Actuated Valves

		Page
	Ball Valves 546	78
	Accessories for Ball Valve 546	94
	Ball Valves 523	99
	Ball Valves 543	101
	Diaphragm Valves 514	118
	Diaphragm Valves 515	121
	Diaphragm Valves 517	123
	Diaphragm Valves 519	127
	Butterfly valves	128
	Cone check valves	138
	Air release valve	146
	Wafer Check Valves 369	148
	Strainers 305	153

		Page
	Ball Valves Electric	156
	Ball Valves Pneumatic	198
	Diaphragm valves pneumatic New generation	244
	Butterfly Valves Electric	276
	Butterfly Valves Pneumatic	289
	Variable area flow meters	298
	Process control valves	311
	Solenoid valves	317

Hand-Operated Valves

General Information

Material

The material PP-H conforms with the corresponding recommendations of the German Federal board of Health.

Standards

All the main dimensions, such as nominal bore, z dimensions, socket depth and diameter, are in accordance with ISO Recommendations, ISO Draft Resolutions for millimetre pipes and DIN 3442.

Fusion joints
EN 558-1 DIN 3442

Thread joint	Flange joint	
ISO 7/1 DIN 2999 BSI 21	DIN 2501/8063	on request ANSI B 16.5 JIS

Joining

Fusion jointing:

Pipes with outside diameter tolerances in accordance with DIN 8077 can be readily jointed with GF Piping Systems Valves.

Threaded joint:

BSP parallel female threads are in accordance with ISO 7/1 or DIN 2999. Threaded plastic Valves should be jointed to plastics pipe or to other plastics parts. Jointing to metal pipe or fittings is permissible only where there is little stress, and should be carried out with great care.

Nominal Pressure

see column PN

Marking

GF Piping Systems valves are marked as follows:

- +GF+
- pipe o.d.
- pipe nominal bore
- material
- pressure rating: PN ...

Overall length

When used with flange adaptors or union ends from GF Piping Systems, the lengths of valves correspond to EN 558-1 (org. DIN 3202) or VSM standard 19431 and NFE 29492.

Dimensions

All dimensions are given in mm.

Information Service

For detailed information see our Catalogue "Plastic Piping Systems".

Quality control conforming to DIN 3442, Part 1

The function and tightness of every valve are factory-tested. Testing is carried out with air under water.

Orders

Always quote the GF Piping Systems code number when placing orders.

Ordering example

8 ball valves 167 346 005

Ball Valves 546

Ball valve type 546 PP-H With mounting inserts With fusion sockets metric

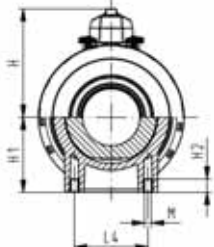
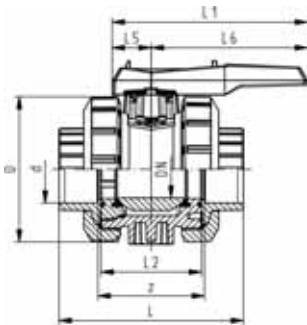
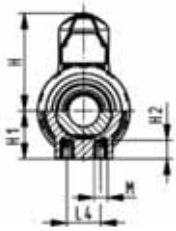
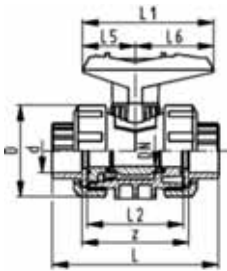

Model:

- Material: PP-H
- For easy installation and removal
- Ball seals PTFE
- Integrated stainless steel mounting inserts
- z-dimension, valve end and union nut are **not compatible** with type 346 (DN10/15-50) resp. type 370 (DN65-100)

Option:

- Individual configuration of the valve (see diagram)
- Multifunctional module with integrated limit switches
- Pneumatic or electric actuators from +GF+

d [mm]	DN [mm]	PN	kv-value ($\Delta p=1$ bar) [l/min]	EPDM Code	FPM Code	kg
16	10	10	71	167 546 401	167 546 411	0.115
20	15	10	185	167 546 402	167 546 412	0.123
25	20	10	350	167 546 403	167 546 413	0.184
32	25	10	700	167 546 404	167 546 414	0.258
40	32	10	1000	167 546 405	167 546 415	0.451
50	40	10	1600	167 546 406	167 546 416	0.617
63	50	10	3100	167 546 407	167 546 417	1.130
75	65	10	5000	167 546 408	167 546 418	3.335
90	80	10	7000	167 546 409	167 546 419	5.500
110	100	10	11000	167 546 410	167 546 420	8.700

d [mm]	D [mm]	H [mm]	H1 [mm]	H2 [mm]	L [mm]	L1 [mm]	L2 [mm]	L4 [mm]	L5 [mm]	L6 [mm]	M	z [mm]
16	50	57	27	12	93	77	56	25	32	45	M6	67
20	50	57	27	12	95	77	56	25	32	45	M6	66
25	58	67	30	12	109	97	65	25	39	58	M6	77
32	68	73	36	12	119	97	71	25	39	58	M6	83
40	84	90	44	15	135	128	85	45	54	74	M8	99
50	97	97	51	15	147	128	89	45	54	74	M8	105
63	124	116	64	15	168	152	101	45	66	87	M8	117
75	166	149	85	15	233	270	136	70	64	206	M8	167
90	200	161	105	15	254	270	141	70	64	206	M8	180
110	238	178	123	22	301	320	164	120	64	256	M12	215



DN10/15 - 50



Ball valve type 546 PP-H With mounting inserts With socket fusion spigots metric

Model:

- Material: PP-H
- For easy installation and removal
- Ball seals PTFE
- Integrated stainless steel mounting inserts
- z-dimension, valve end and union nut are **not compatible** with type 346 (DN10/15-50) resp. type 370 (DN65-100)

Option:

- Individual configuration of the valve (see diagram)
- Multifunctional module with integrated limit switches
- Pneumatic or electric actuators from +GF+

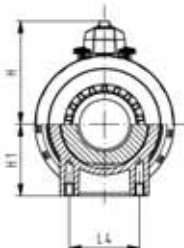
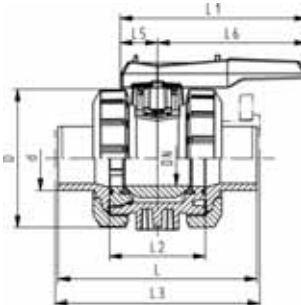
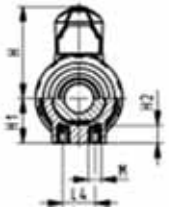
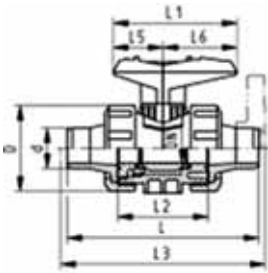

d [mm]	DN [mm]	PN	kv-value ($\Delta p=1$ bar) [l/min]	EPDM Code	FPM Code	kg
16	10	10	71	167 546 041	167 546 051	0.120
20	15	10	185	167 546 042	167 546 052	0.120
25	20	10	350	167 546 043	167 546 053	0.180
32	25	10	700	167 546 044	167 546 054	0.260
40	32	10	1000	167 546 045	167 546 055	0.450
50	40	10	1600	167 546 046	167 546 056	0.640
63	50	10	3100	167 546 047	167 546 057	1.210
75	65	10	5000	167 546 048	167 546 058	3.800
90	80	10	7000	167 546 049	167 546 059	5.600
110	100	10	11000	167 546 050	167 546 060	8.800

d [mm]	D [mm]	H [mm]	H1 [mm]	H2 [mm]	L [mm]	L1 [mm]	L2 [mm]	L3 [mm]	L4 [mm]	L5 [mm]	L6 [mm]	M
16	50	57	27	12	110	77	56		25	32	45	M6
20	50	57	27	12	120	77	56	130	25	32	45	M6
25	58	67	30	12	139	97	65	150	25	39	58	M6
32	68	73	36	12	150	97	71	160	25	39	58	M6
40	84	90	44	15	170	128	85	180	45	54	74	M8
50	97	97	51	15	190	128	89	200	45	54	74	M8
63	124	116	64	15	220	152	101	230	45	66	87	M8
75	166	149	85	15	280	270	136	290	70	64	206	M8
90	200	161	105	15	296	270	141	310	70	64	206	M8
110	238	178	123	22	336	320	164	350	120	64	256	M12

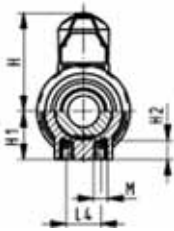
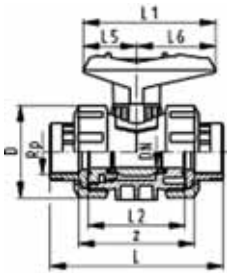

Ball valve type 546 PP-H With mounting inserts With threaded sockets reinforced Rp

Model:

- Material: PP-H
- For easy installation and removal
- Ball seals PTFE
- Integrated stainless steel mounting inserts
- z-dimension, valve end and union nut are not compatible with type 346

Option:

- Individual configuration of the valve (see diagram)
- Multifunctional module with integrated limit switches
- Pneumatic or electric actuators from +GF+

Rp [inch]	DN [mm]	PN	kv-value ($\Delta p=1$ bar) [l/min]	EPDM Code	FPM Code	kg
3/8	10	10	71	167 546 021	167 546 031	0.120
1/2	15	10	185	167 546 022	167 546 032	0.120
3/4	20	10	350	167 546 023	167 546 033	0.180
1	25	10	700	167 546 024	167 546 034	0.270
1 1/4	32	10	1000	167 546 025	167 546 035	0.460
1 1/2	40	10	1600	167 546 026	167 546 036	0.635
2	50	10	3100	167 546 027	167 546 037	1.190

Rp [inch]	D [mm]	H [mm]	H1 [mm]	H2 [mm]	L [mm]	L1 [mm]	L2 [mm]	L4 [mm]	L5 [mm]	L6 [mm]	M	z [mm]
3/8	50	57	27	12	96	77	56	25	32	45	M6	69
1/2	50	57	27	12	99	77	56	25	32	45	M6	67
3/4	58	67	30	12	111	97	65	25	39	58	M6	78
1	68	73	36	12	127	97	71	25	39	58	M6	85
1 1/4	84	90	44	15	146	128	85	45	54	74	M8	100
1 1/2	97	97	51	15	157	128	89	45	54	74	M8	106
2	124	116	64	15	183	152	101	45	66	87	M8	121



DN10/15 - 50

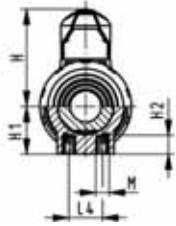
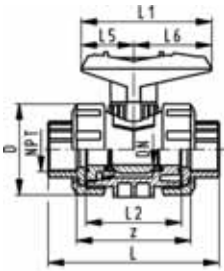

Ball valve type 546 PP-H With mounting inserts With threaded sockets reinforced NPT

Model:

- Material: PP-H
- For easy installation and removal
- Ball seals PTFE
- Integrated stainless steel mounting inserts
- z-dimension, valve end and union nut are not compatible with type 346

Option:

- Individual configuration of the valve (see diagram)
- Multifunctional module with integrated limit switches
- Pneumatic or electric actuators from +GF+

NPT [inch]	DN [mm]	PN	kv-value ($\Delta p=1$ bar) [l/min]	EPDM Code	FPM Code	kg
3/8	10	10	71	167 546 321	167 546 331	0.120
1/2	15	10	185	167 546 322	167 546 332	0.120
3/4	20	10	350	167 546 323	167 546 333	0.180
1	25	10	700	167 546 324	167 546 334	0.270
1 1/4	32	10	1000	167 546 325	167 546 335	0.460
1 1/2	40	10	1600	167 546 326	167 546 336	0.635
2	50	10	3100	167 546 327	167 546 337	1.190

NPT [inch]	D [mm]	H [mm]	H1 [mm]	H2 [mm]	L [mm]	L1 [mm]	L2 [mm]	L4 [mm]	L5 [mm]	L6 [mm]	M	z [mm]
3/8	50	57	27	12	96	77	56	25	32	45	M6	71
1/2	50	57	27	12	99	77	56	25	32	45	M6	64
3/4	58	67	30	12	111	97	65	25	39	58	M6	76
1	68	73	36	12	127	97	71	25	39	58	M6	83
1 1/4	84	90	44	15	146	128	85	45	54	74	M8	100
1 1/2	97	97	51	15	157	128	89	45	54	74	M8	111
2	124	116	64	15	183	152	101	45	66	87	M8	134



DN10/15 - 50

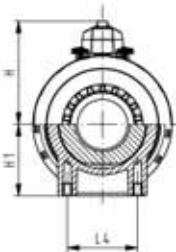
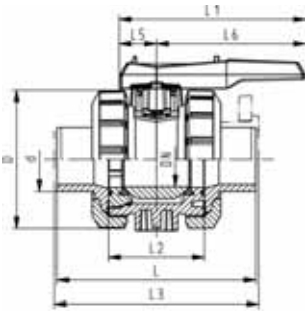
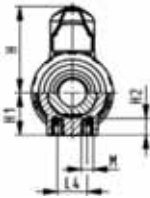
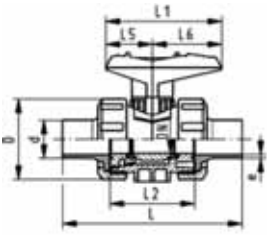

Ball valve type 546 PP-H With mounting inserts With butt fusion spigots IR-Plus SDR11 metric

Model:

- Material: PP-H
- For easy installation and removal
- Ball seals PTFE
- Integrated stainless steel mounting inserts
- z-dimension, valve end and union nut are **not compatible** with type 346 (DN10/15-50) resp. type 370 (DN65-100)

Option:

- Individual configuration of the valve (see diagram)
- Multifunctional module with integrated limit switches
- Pneumatic or electric actuators from +GF+

d [mm]	DN [mm]	PN	kv-value ($\Delta p=1$ bar) [l/min]	EPDM Code	FPM Code	kg
20	15	10	185	167 546 442	167 546 452	0.123
25	20	10	350	167 546 443	167 546 453	0.185
32	25	10	700	167 546 444	167 546 454	0.263
40	32	10	1000	167 546 445	167 546 455	0.456
50	40	10	1600	167 546 446	167 546 456	0.642
63	50	10	3100	167 546 447	167 546 457	1.180
75	65	10	5000	167 546 448	167 546 458	2.602
90	80	10	7000	167 546 449	167 546 459	5.500
110	100	10	11000	167 546 450	167 546 460	8.700

d [mm]	D [mm]	H [mm]	H1 [mm]	H2 [mm]	L [mm]	L1 [mm]	L2 [mm]	L4 [mm]	L5 [mm]	L6 [mm]	M	e [mm]
20	50	57	27	12	130	77	56	25	32	45	M6	1.9
25	58	67	30	12	143	97	65	25	39	58	M6	2.3
32	68	73	36	12	150	97	71	25	39	58	M6	2.9
40	84	90	44	15	171	128	85	45	54	74	M8	3.7
50	97	97	51	15	191	128	89	45	54	74	M8	4.6
63	124	116	64	15	220	152	101	45	66	87	M8	5.8
75	166	149	85	15	266	270	136	70	64	206	M8	6.8
90	200	161	105	15	264	270	141	70	64	206	M8	8.2
110	238	178	123	22	301	320	164	120	64	256	M12	10.0



DN10/15 - 50

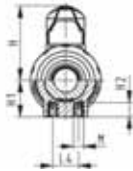
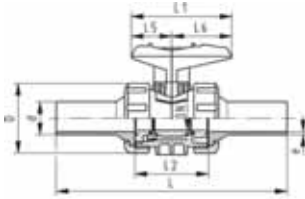

Ball valve type 546 PP-H With mounting inserts With butt fusion spigots long SDR11 metric

Model:

- Material: PP-H
- For easy installation and removal
- Ball seals PTFE
- Integrated stainless steel mounting inserts
- z-dimension, valve end and union nut are not compatible with type 346

Option:

- Individual configuration of the valve (see diagram)
- Multifunctional module with integrated limit switches
- Pneumatic or electric actuators from +GF+

d [mm]	DN [mm]	PN	kv-value ($\Delta p=1$ bar) [l/min]	EPDM Code	FPM Code	kg	
20	15	10	185	167 546 262	167 546 272	0.130	
25	20	10	350	167 546 263	167 546 273	0.195	
32	25	10	700	167 546 264	167 546 274	0.280	
40	32	10	1000	167 546 265	167 546 275	0.480	
50	40	10	1600	167 546 266	167 546 276	0.700	
63	50	10	3100	167 546 267	167 546 277	1.288	

d [mm]	D [mm]	H [mm]	H1 [mm]	H2 [mm]	L [mm]	L1 [mm]	L2 [mm]	L4 [mm]	L5 [mm]	L6 [mm]	M	e [mm]	
20	50	57	27	12	193	77	56	25	32	45	M6	2,3	
25	58	67	30	12	216	97	65	25	39	58	M6	2,3	
32	68	73	36	12	223	97	71	25	39	58	M6	2,9	
40	84	90	44	15	249	128	85	45	54	74	M8	3,7	
50	97	97	51	15	271	128	89	45	54	74	M8	4,6	
63	124	116	64	15	321	152	101	45	66	87	M8	5,8	



DN10/15 - 50



Ball valve type 546 PP-H With mounting inserts With butt fusion spigots SDR17.6 metric

Model:

- Material: PP-H
- For easy installation and removal
- Ball seals PTFE
- Integrated stainless steel mounting inserts
- z-dimension, valve end and union nut are **not compatible** with type 346 (DN10/15-50) resp. type 370 (DN65-100)

Option:

- Individual configuration of the valve (see diagram)
- Multifunctional module with integrated limit switches
- Pneumatic or electric actuators from +GF+

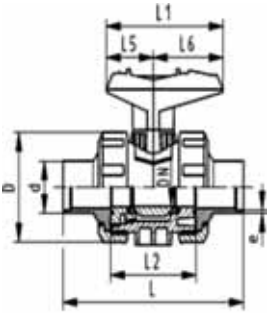

d [mm]	DN [mm]	PN	kv-value ($\Delta p=1$ bar) [l/min]	EPDM Code	FPM Code	kg
50	40	6	1600	167 546 066	167 546 076	0.635
63	50	6	3100	167 546 067	167 546 077	1.200
75	65	6	5000	167 546 068	167 546 078	3.387
90	80	6	7000	167 546 069	167 546 079	5.500
110	100	6	11000	167 546 070	167 546 080	8.600

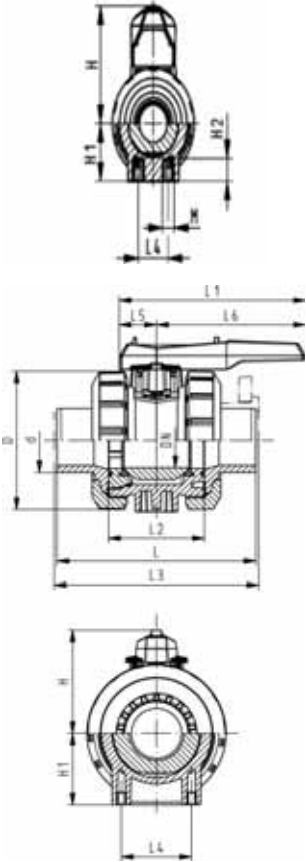

d [mm]	D [mm]	H [mm]	H1 [mm]	H2 [mm]	L [mm]	L1 [mm]	L2 [mm]	L4 [mm]	L5 [mm]	L6 [mm]	M	e [mm]
50	97	97	51	15	191	128	89	45	54	74	M8	2,9
63	124	116	64	15	220	152	101	45	66	87	M8	3,6
75	166	149	85	15	266	270	136	70	64	206	M8	4,7
90	200	161	105	15	264	270	141	70	64	206	M8	5,5
110	238	178	123	22	301	320	164	120	64	256	M12	6,8



Ball valve type 546 PP-H With mounting inserts With fusion sockets PE100 metric

Model:

- Material: PP-H
- For easy installation and removal
- Ball seals PTFE
- Integrated stainless steel mounting inserts
- z-dimension, valve end and union nut are not compatible with type 346

Option:

- Individual configuration of the valve (see diagram)
- Multifunctional module with integrated limit switches
- Pneumatic or electric actuators from +GF+

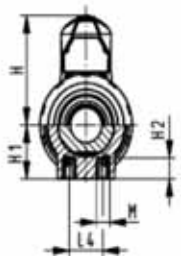
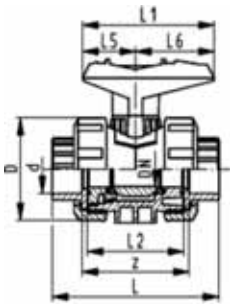

d [mm]	DN [mm]	PN	kv-value ($\Delta p=1$ bar) [l/min]	EPDM Code	FPM Code	kg	
16	10	10	71	167 546 161	167 546 171	0.120	
20	15	10	185	167 546 162	167 546 172	0.120	
25	20	10	350	167 546 163	167 546 173	0.180	
32	25	10	700	167 546 164	167 546 174	0.260	
40	32	10	1000	167 546 165	167 546 175	0.450	
50	40	10	1600	167 546 166	167 546 176	0.630	
63	50	10	3100	167 546 167	167 546 177	1.195	

d [mm]	D [mm]	H [mm]	H1 [mm]	H2 [mm]	L [mm]	L1 [mm]	L2 [mm]	L4 [mm]	L5 [mm]	L6 [mm]	M	z [mm]	
16	50	57	27	12	93	77	56	25	32	45	M6	67	
20	50	57	27	12	95	77	56	25	32	45	M6	67	
25	58	67	30	12	109	97	65	25	39	58	M6	77	
32	68	73	36	12	119	97	71	25	39	58	M6	83	
40	84	90	44	15	135	128	85	45	54	74	M8	99	
50	97	97	51	15	147	128	89	45	54	74	M8	105	
63	124	116	64	15	168	152	101	45	66	87	M8	113	



Ball valve type 546 PP-H With mounting inserts With butt fusion spigots PE100 SDR11 metric

Model:

- Material: PP-H
- For easy installation and removal
- Ball seals PTFE
- Integrated stainless steel mounting inserts
- z-dimension, valve end and union nut are not compatible with type 346

Option:

- Individual configuration of the valve (see diagram)
- Multifunctional module with integrated limit switches
- Pneumatic or electric actuators from +GF+

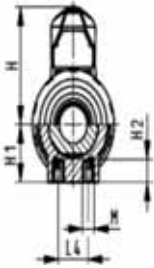
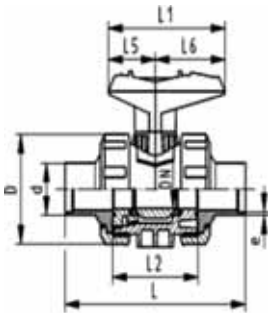

d [mm]	DN [mm]	PN	kv-value ($\Delta p=1$ bar) [l/min]	EPDM Code	FPM Code	kg
20	15	10	185	167 546 142	167 546 152	0.120
25	20	10	350	167 546 143	167 546 153	0.180
32	25	10	700	167 546 144	167 546 154	0.255
40	32	10	1000	167 546 145	167 546 155	0.440
50	40	10	1600	167 546 146	167 546 156	0.620
63	50	10	3100	167 546 147	167 546 157	1.200

d [mm]	D [mm]	H [mm]	H1 [mm]	H2 [mm]	L [mm]	L1 [mm]	L2 [mm]	L3 [mm]	L4 [mm]	L5 [mm]	L6 [mm]	M	e [mm]
20	50	57	27	12	130	77	56	130	25	32	45	M6	1,9
25	58	67	30	12	143	97	65	150	25	39	58	M6	2,3
32	68	73	36	12	150	97	71	160	25	39	58	M6	2,9
40	84	90	44	15	171	128	85	180	45	54	74	M8	3,7
50	97	97	51	15	191	128	89	200	45	54	74	M8	4,6
63	124	116	64	15	220	152	101	230	45	66	87	M8	5,8

Ball valve type 546 PP-H With mounting inserts With butt fusion spigots long PE100 SDR11 metric



DN10/15 - 50



Model:

- Material: PP-H
- For easy installation and removal
- Ball seals PTFE
- Integrated stainless steel mounting inserts
- z-dimension, valve end and union nut are **not compatible** with type 346 (DN10/15-50) resp. type 370 (DN65-100)

Option:

- Individual configuration of the valve (see diagram)
- Multifunctional module with integrated limit switches
- Pneumatic or electric actuators from +GF+

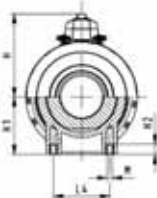
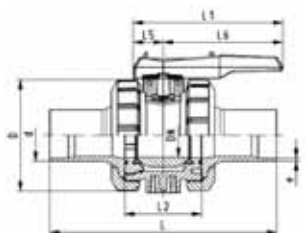
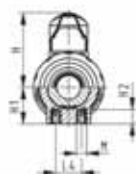
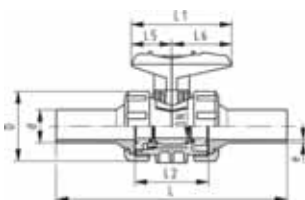

d [mm]	DN [mm]	PN	kv-value ($\Delta p=1$ bar) [l/min]	EPDM Code	FPM Code	kg
20	15	10	185	167 546 282	167 546 292	0.130
25	20	10	350	167 546 283	167 546 293	0.195
32	25	10	700	167 546 284	167 546 294	0.280
40	32	10	1000	167 546 285	167 546 295	0.485
50	40	10	1600	167 546 286	167 546 296	0.695
63	50	10	3100	167 546 287	167 546 297	1.309
75	65	10	5000	167 546 288	167 546 298	3.900
90	80	10	7000	167 546 289	167 546 299	5.900
110	100	10	11000	167 546 290	167 546 300	9.300

d [mm]	D [mm]	H [mm]	H1 [mm]	H2 [mm]	L [mm]	L1 [mm]	L2 [mm]	L4 [mm]	L5 [mm]	L6 [mm]	M	e [mm]
20	50	57	27	12	193	77	56	25	32	45	M6	2,3
25	58	67	30	12	216	97	65	25	39	58	M6	2,3
32	68	73	36	12	223	97	71	25	39	58	M6	2,9
40	84	90	44	15	249	128	85	45	54	74	M8	3,7
50	97	97	51	15	271	128	89	45	54	74	M8	4,6
63	124	116	64	15	321	152	101	45	66	87	M8	5,8
75	166	149	85	15	386	270	136	70	64	206	M8	6,8
90	200	161	105	15	421	270	141	70	64	206	M8	8,2
110	238	178	123	22	484	320	164	120	64	256	M12	10,0



Ball valve type 546 PP-H With mounting inserts With butt fusion spigots PE100 SDR17.6 metric

Model:

- Material: PP-H
- For easy installation and removal
- Ball seals PTFE
- Integrated stainless steel mounting inserts
- z-dimension, valve end and union nut are not compatible with type 346

Option:

- Individual configuration of the valve (see diagram)
- Multifunctional module with integrated limit switches
- Pneumatic or electric actuators from +GF+

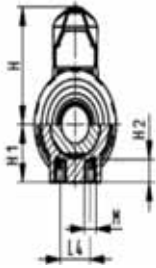
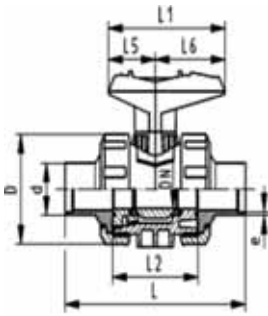

d [mm]	DN [mm]	PN	kv-value ($\Delta p=1$ bar) [l/min]	EPDM Code	FPM Code	kg
50	40	6	1600	167 546 126	167 546 136	0.620
63	50	6	3100	167 546 127	167 546 137	1.200

d [mm]	D [mm]	H [mm]	H1 [mm]	H2 [mm]	L [mm]	L1 [mm]	L2 [mm]	L4 [mm]	L5 [mm]	L6 [mm]	M	e [mm]
50	97	97	51	15	191	128	89	45	54	74	M8	2,9
63	124	116	64	15	220	152	101	45	66	87	M8	3,6



PROGEF Standard Ball valve type 546 With mounting inserts With butt fusion spigots long PE100 SDR17,6 metric

Model:

- Material: PP-H
- For easy installation and removal
- Ball seals PTFE
- Integrated stainless steel mounting inserts
- z-dimension, valve end and union nut are **not compatible** with type 346 (DN10/15-50) resp. type 370 (DN65-100)

Option:

- Individual configuration of the valve (see diagram)
- Multifunctional module with integrated limit switches
- Pneumatic or electric actuators from +GF+

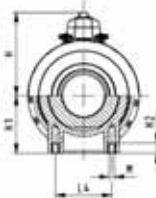
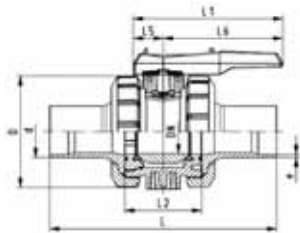

d [mm]	DN [mm]	PN	kv-value ($\Delta p=1$ bar) [l/min]	EPDM Code	FPM Code	kg
75	65	10	5000	167 546 308	167 546 318	3.900
90	80	10	7000	167 546 309	167 546 319	2.026
110	100	10	11000	167 546 310	167 546 320	9.200

d [mm]	D [mm]	H [mm]	H1 [mm]	H2 [mm]	L [mm]	L1 [mm]	L2 [mm]	L4 [mm]	L5 [mm]	L6 [mm]	M	e [mm]
75	166	149	85	15	386	270	136	70	64	206	8	4.3
90	200	161	105	15	421	270	141	70	64	206	8	5.1
110	238	178	123	22	484	320	164	120	64	256	12	6.3



PROGEF Standard Ball valve type 546 With mounting inserts With backing flanges PP-st metric

Model:

- Material: PP-H
- For easy installation and removal
- Ball seals PTFE
- Integrated stainless steel mounting inserts
- z-dimension, valve end and union nut are **not compatible** with type 346 (DN10/15-50) resp. type 370 (DN65-100)
- Overall length according to EN 558
- Connecting dimension: ISO 7005, EN 1092, BS 4504, DIN 2501

Option:

- Individual configuration of the valve (see diagram)
- Multifunctional module with integrated limit switches
- Pneumatic or electric actuators from +GF+

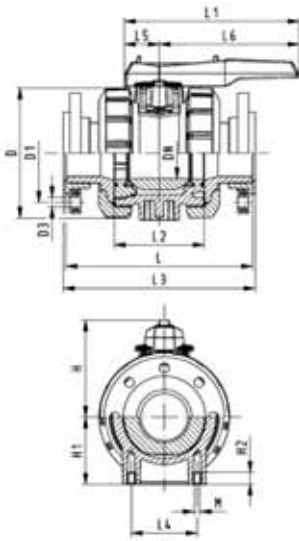

d [mm]	DN [mm]	PN	kv-value ($\Delta p=1$ bar) [l/min]	EPDM Code	FPM Code	kg
75	65	10	5000	167 546 808	167 546 818	5.417
90	80	10	7000	167 546 809	167 546 819	7.941
110	100	10	11000	167 546 810	167 546 820	9.928

d [mm]	D [mm]	D1 [mm]	D3 [mm]	L [mm]	L1 [mm]	L2 [mm]	L3 [mm]	L4 [mm]	L5 [mm]	L6 [mm]	H [mm]	H1 [mm]	M
75	166	145	18	280	270	136	290	70	64	206	149	85	8
90	200	160	18	296	270	141	310	70	64	206	161	105	8
110	238	180	18	336	320	164	350	120	64	256	178	123	12



DN10/15 - 50

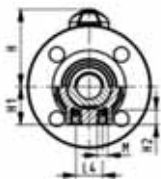
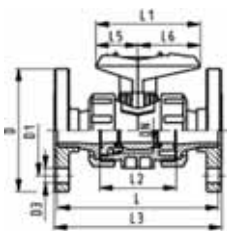

PROGEF Standard Ball valve type 546 With mounting inserts With fixed flanges PP-H serrated metric

Model:

- Material: PP-H
- For easy installation and removal
- Ball seals PTFE
- Integrated stainless steel mounting inserts
- z-dimension, valve end and union nut are not compatible with type 346
- Connecting dimensions: ISO 7005 / EN 1092 / DIN 2501 PN10 / BS4504
- Overall length EN 558

Option:

- Individual configuration of the valve (see diagram)
- Multifunctional module with integrated limit switches
- Pneumatic or electric actuators from +GF+

d [mm]	DN [mm]	Inch	PN	kv-value ($\Delta p=1$ bar) [l/min]	EPDM Code	FPM Code	kg
20	15	½	10	185	167 546 182	167 546 192	0.245
25	20	¾	10	350	167 546 183	167 546 193	0.345
32	25	1	10	700	167 546 184	167 546 194	0.495
40	32	1 ¼	10	1000	167 546 185	167 546 195	0.824
50	40	1 ½	10	1600	167 546 186	167 546 196	1.066
63	50	2	10	3100	167 546 187	167 546 197	1.751

d [mm]	D [mm]	D1 [mm]	D3 [mm]	H [mm]	H1 [mm]	H2 [mm]	L [mm]	L1 [mm]	L2 [mm]	L3 [mm]	L4 [mm]	L5 [mm]	L6 [mm]	M
20	95	65	14	57	27	12	120	77	56	130	25	32	45	M6
25	105	75	14	67	30	12	140	97	65	150	25	39	58	M6
32	115	85	14	73	36	12	150	97	71	160	25	39	58	M6
40	140	100	18	90	44	15	170	128	85	180	45	54	74	M8
50	150	110	18	97	51	15	190	128	89	200	45	54	74	M8
63	165	125	18	116	64	15	220	152	101	230	45	66	87	M8



DN10/15 - 50

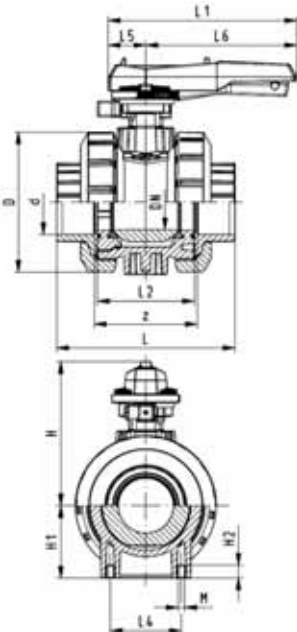
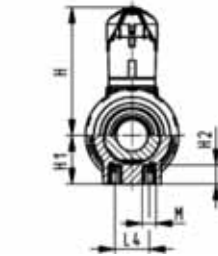
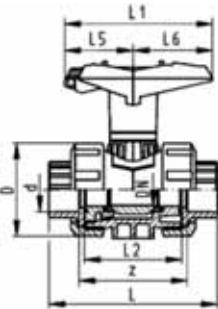

Ball valve type 546 PP-H With lockable handle With fusion sockets metric

Model:

- Material: PP-H
- For easy installation and removal
- Ball seals PTFE
- Integrated stainless steel mounting inserts
- z-dimension, valve end and union nut are **not compatible** with type 346 (DN10/15-50) resp. type 370 (DN65-100)
- Lockable hand lever with ratchet settings

Option:

- Individual configuration of the valve (see diagram)
- Multifunctional module with integrated limit switches
- Pneumatic or electric actuators from +GF+

d [mm]	DN [mm]	PN	kv-value ($\Delta p=1$ bar) [l/min]	EPDM Code	FPM Code	kg
16	10	10	71	167 546 421	167 546 431	0.125
20	15	10	185	167 546 422	167 546 432	0.125
25	20	10	350	167 546 423	167 546 433	0.195
32	25	10	700	167 546 424	167 546 434	0.270
40	32	10	1000	167 546 425	167 546 435	0.465
50	40	10	1600	167 546 426	167 546 436	0.635
63	50	10	3100	167 546 427	167 546 437	1.175
75	65	10	5000	167 546 428	167 546 438	4.000
90	80	10	7000	167 546 429	167 546 439	4.715
110	100	10	11000	167 546 430	167 546 440	7.252

d [mm]	D [mm]	H [mm]	H1 [mm]	H2 [mm]	L [mm]	L1 [mm]	L2 [mm]	L4 [mm]	L5 [mm]	L6 [mm]	M	z [mm]
16	50	79	27	12	93	77	56	25	32	45	M6	67
20	50	79	27	12	95	77	56	25	32	45	M6	66
25	58	88	30	12	109	97	65	25	39	58	M6	77
32	68	94	36	12	119	97	71	25	39	58	M6	83
40	84	113	44	15	135	128	85	45	54	74	M8	99
50	97	119	51	15	147	128	89	45	54	74	M8	105
63	124	141	64	15	168	152	101	45	66	87	M8	117
75	166	224	85	15	233	270	136	70	64	206	M8	167
90	200	235	105	15	254	270	141	70	64	206	M8	180
110	238	245	123	22	301	320	164	120	64	256	M12	215

Ball valve type 546 PP-H With lockable handle With butt fusion spigots IR-Plus SDR11 metric

Model:

- Material: PP-H
- For easy installation and removal
- Ball seals PTFE
- Integrated stainless steel mounting inserts
- z-dimension, valve end and union nut are **not compatible** with type 346 (DN10/15-50) resp. type 370 (DN65-100)
- Lockable hand lever with ratchet settings

Option:

- Individual configuration of the valve (see diagram)
- Multifunctional module with integrated limit switches
- Pneumatic or electric actuators from +GF+



DN10/15 - 50

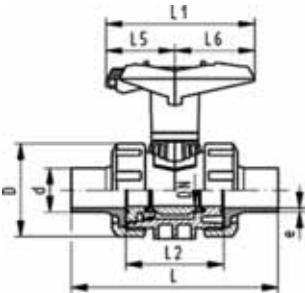

d [mm]	DN [mm]	PN	kv-value ($\Delta p=1$ bar) [l/min]	EPDM Code	FPM Code	kg
20	15	10	185	167 546 462	167 546 472	0.130
25	20	10	350	167 546 463	167 546 473	0.195
32	25	10	700	167 546 464	167 546 474	0.270
40	32	10	1000	167 546 465	167 546 475	0.465
50	40	10	1600	167 546 466	167 546 476	0.645
63	50	10	3100	167 546 467	167 546 477	1.213
75	65	10	5000	167 546 468	167 546 478	4.100
90	80	10	7000	167 546 469	167 546 479	5.900
110	100	10	11000	167 546 470	167 546 480	9.000

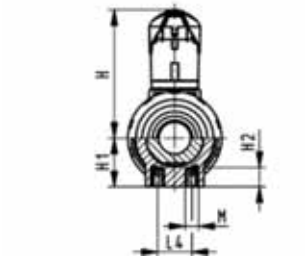

d [mm]	D [mm]	H [mm]	H1 [mm]	H2 [mm]	L [mm]	L1 [mm]	L2 [mm]	L4 [mm]	L5 [mm]	L6 [mm]	M	e [mm]
20	50	79	27	12	130	87	56	25	42	45	M6	1,9
25	58	88	30	12	143	108	65	25	50	58	M6	2,3
32	68	94	36	12	150	108	71	25	50	58	M6	2,9
40	84	113	44	15	171	140	85	45	66	75	M8	3,7
50	97	119	51	15	191	140	89	45	66	75	M8	4,6
63	124	141	64	15	220	165	101	45	78	87	M8	5,8
75	166	149	85	15	266	270	136	70	64	206	M8	6,8
90	200	161	105	15	264	270	141	70	64	206	M8	8,2
110	238	178	123	22	301	320	164	120	64	256	M12	10,0

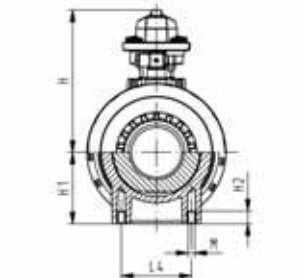
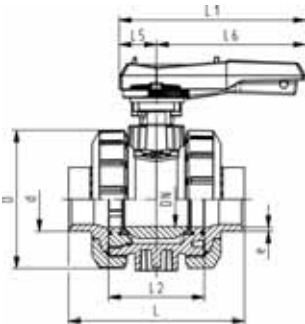



DN10/15 - 50

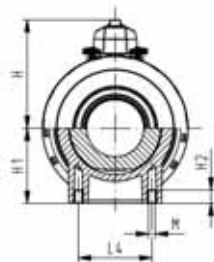
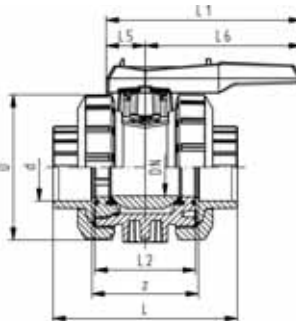
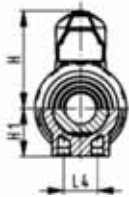
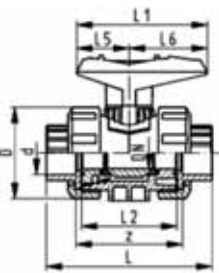

Ball valve type 546 PP-H With fusion sockets metric

Model:

- Material: PP-H
- For easy installation and removal
- z-dimension, valve end and union nut are **not compatible** with type 346 (DN10/15-50) resp. type 370 (DN65-100)
- Ball seals PTFE
- Without mounting inserts

Option:

- Individual configuration of the valve (see diagram)
- Multifunctional module with integrated limit switches
- Pneumatic or electric actuators from +GF+

d [mm]	DN [mm]	PN	kv-value ($\Delta p=1$ bar) [l/min]	EPDM Code	FPM Code	kg
16	10	10	71	167 546 001	167 546 011	0.115
20	15	10	185	167 546 002	167 546 012	0.115
25	20	10	350	167 546 003	167 546 013	0.178
32	25	10	700	167 546 004	167 546 014	0.253
40	32	10	1000	167 546 005	167 546 015	0.442
50	40	10	1600	167 546 006	167 546 016	0.607
63	50	10	3100	167 546 007	167 546 017	1.118
75	65	10	5000	167 546 008	167 546 018	3.345
90	80	10	7000	167 546 009	167 546 019	5.500
110	100	10	11000	167 546 010	167 546 020	8.700

d [mm]	D [mm]	H [mm]	H1 [mm]	L [mm]	L1 [mm]	L2 [mm]	L4 [mm]	L5 [mm]	L6 [mm]	z [mm]
16	50	57	27	93	77	56	25	32	45	67
20	50	57	27	95	77	56	25	32	45	66
25	58	67	30	109	97	65	25	39	58	77
32	68	73	36	119	97	71	25	39	58	83
40	84	90	44	135	128	85	45	54	74	99
50	97	97	51	147	128	89	45	54	74	105
63	124	116	64	168	152	101	45	66	87	117
75	166	149	85	233	270	136	70	64	206	167
90	200	161	105	254	270	141	70	64	206	180
110	238	178	123	301	320	164	120	64	256	215

Accessories for Ball Valve 546

Multifunctional module (I02) PP-GF Module empty



DN10/15 - 50

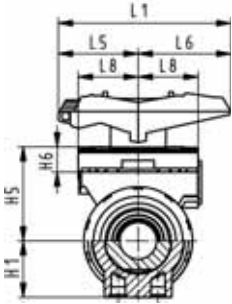
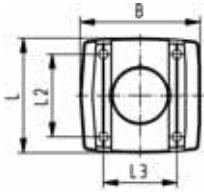

Model:

- Accessory to Ball Valve Type 546
- Multifunctional module acts as an intermediate element for actuators
- For operation with handle, multifunctional handle has to be ordered separately.
- Including screws to mount the module and stainless steel coupling piece (V2A) for dimension DN65-100
- The multifunctional module from d75 - d110 has a master gauge F07 according to EN ISO 5211.

d-d [mm]	Inch [inch]	DN-DN [mm]	Code	kg
16 - 20	3/8 - 1/2	10 - 15	167 482 680	0.069
25 - 32	3/4 - 1	20 - 25	167 482 681	0.149
40 - 50	1 1/4 - 1 1/2	32 - 40	167 482 682	0.168
- 63	2	- 50	167 482 683	0.209
75 - 90	2 1/2 - 3	65 - 80	167 482 684	0.379
- 110	4	- 100	167 482 685	0.607

d-d [mm]	B [mm]	H1 [mm]	H5 [mm]	H6 [mm]	L [mm]	L1 [mm]	L2 [mm]	L3 [mm]	L5 [mm]	L6 [mm]	L8 [mm]
16 - 20	67	27	50	17	72	87	54	40	42	45	34
25 - 32	75	30	53	16	72	108	52	46	50	58	38
40 - 50	81	44	72	16	80	140	60	50	66	75	41
- 63	91	64	94	19	93	165	68	65	78	87	46
75 - 90	90	85	157	23	85	270			64	206	
- 110	106	123	175	23	97	320			64	256	

Multifunctional module (I03) PP-GF With mechanical limit switches Ag Ni



DN10/15 - 50

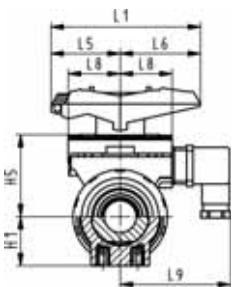

Model:

- Accessory to Ball Valve Type 546
- Multifunctional module acts as an intermediate element for actuators
- For operation with handle, multifunctional handle has to be ordered separately.
- Including Plug 3P+E / Protection: IP65
- Including screws to mount the module and stainless steel coupling piece (V2A) for dimension DN65-100

d-d [mm]	Inch [inch]	DN-DN [mm]	Code	kg	H1 [mm]	H5 [mm]	L1 [mm]	L5 [mm]	L6 [mm]	L8 [mm]	L9 [mm]
16 - 20	3/8 - 1/2	10 - 15	167 482 626	0.104	27	50	87	42	45	34	73
25 - 32	3/4 - 1	20 - 25	167 482 627	0.118	30	53	108	50	58	38	77
40 - 50	1 1/4 - 1 1/2	32 - 40	167 482 628	0.140	44	72	140	66	75	41	80
- 63	2	- 50	167 482 629	0.257	64	94	165	78	87	46	85
75 - 90	2 1/2 - 3	65 - 80	167 482 630	0.478	85	157	270	64	206		
- 110	4	- 100	167 482 631	0.480	123	175	320	64	256		



DN10/15 - 50

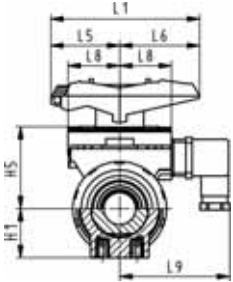

Multifunctional module (I04) PP-GF With mechanical limit switches Au

Model:

- Accessory to Ball Valve Type 546
- Multifunctional module acts as an intermediate element for actuators
- For operation with handle, multifunctional handle has to be ordered separately.
- Including Plug 3P+E / Protection: IP65
- Including screws to mount the module and stainless steel coupling piece (V2A) for dimension DN65-100

d-d [mm]	Inch [inch]	DN-DN [mm]	Code	kg	H1 [mm]	H5 [mm]	L1 [mm]	L5 [mm]	L6 [mm]	L8 [mm]	L9 [mm]
16 - 20	3/8 - 1/2	10 - 15	167 482 635	0.103	27	50	87	42	45	34	73
25 - 32	3/4 - 1	20 - 25	167 482 636	0.120	30	53	108	50	58	38	77
40 - 50	1 1/4 - 1 1/2	32 - 40	167 482 637	0.138	44	72	140	66	75	41	80
- 63	2	- 50	167 482 638	0.175	64	94	165	78	87	46	85
75 - 90	2 1/2 - 3	65 - 80	167 482 639	0.460	85	157	270	64	206		
- 110	4	- 100	167 482 640	0.480	123	175	320	64	256		



DN10/15 - 50

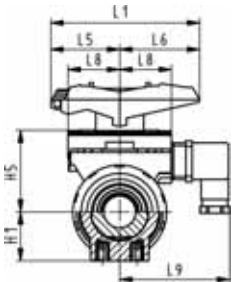

Multifunctional module (I05) PP-GF With inductive limit switches Namur

Model:

- Accessory to Ball Valve Type 546
- Multifunctional module acts as an intermediate element for actuators
- For operation with handle, multifunctional handle has to be ordered separately.
- Including Plug 3P+E / Protection: IP65
- Including screws to mount the module and stainless steel coupling piece (V2A) for dimension DN65-100

d-d [mm]	Inch [inch]	DN-DN [mm]	Code	kg	H1 [mm]	H5 [mm]	L1 [mm]	L5 [mm]	L6 [mm]	L8 [mm]	L9 [mm]
16 - 20	3/8 - 1/2	10 - 15	167 482 671	0.097	27	50	87	42	45	34	73
25 - 32	3/4 - 1	20 - 25	167 482 672	0.107	30	53	108	50	58	38	77
40 - 50	1 1/4 - 1 1/2	32 - 40	167 482 673	0.135	44	72	140	66	75	41	80
- 63	2	- 50	167 482 674	0.257	64	94	165	78	87	46	85
75 - 90	2 1/2 - 3	65 - 80	167 482 675	0.460	85	157	270	64	206		
- 110	4	- 100	167 482 676	0.480	123	175	320	64	256		



DN10/15 - 50

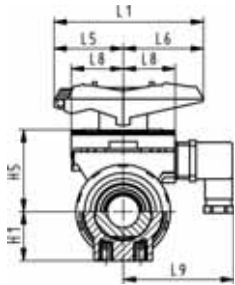

Multifunctional module (I06) PP-GF With inductive limit switches PNP

Model:

- Accessory to Ball Valve Type 546
- Multifunctional module acts as an intermediate element for actuators
- For operation with handle, multifunctional handle has to be ordered separately.
- Including Plug 3P+E / Protection: IP65
- Including screws to mount the module and stainless steel coupling piece (V2A) for dimension DN65-100

d-d [mm]	Inch [inch]	DN-DN [mm]	Code	kg	H1 [mm]	H5 [mm]	L1 [mm]	L5 [mm]	L6 [mm]	L8 [mm]	L9 [mm]
16 - 20	3/8 - 1/2	10 - 15	167 482 662	0.182	27	50	87	42	45	34	73
25 - 32	3/4 - 1	20 - 25	167 482 663	0.197	30	53	108	50	58	38	77
40 - 50	1 1/4 - 1 1/2	32 - 40	167 482 664	0.215	44	72	140	66	75	41	80
- 63	2	- 50	167 482 665	0.175	64	94	165	78	87	46	85
75 - 90	2 1/2 - 3	65 - 80	167 482 666	0.460	85	157	270	64	206		
- 110	4	- 100	167 482 667	0.480	123	175	320	64	256		



DN10/15 - 50

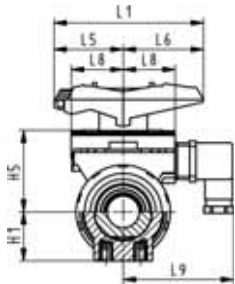

Multifunctional module (I07) PP-GF With inductive limit switches NPN

Model:

- Accessory to Ball Valve Type 546
- Multifunctional module acts as an intermediate element for actuators
- For operation with handle, multifunctional handle has to be ordered separately.
- Including Plug 3P+E / Protection: IP65
- Including screws to mount the module and stainless steel coupling piece (V2A) for dimension DN65-100

d-d [mm]	Inch [inch]	DN-DN [mm]	Code	kg	H1 [mm]	H5 [mm]	L1 [mm]	L5 [mm]	L6 [mm]	L8 [mm]	L9 [mm]
16 - 20	3/8 - 1/2	10 - 15	167 482 653	0.110	27	50	87	42	45	34	73
25 - 32	3/4 - 1	20 - 25	167 482 654	0.120	30	53	108	50	58	38	77
40 - 50	1 1/4 - 1 1/2	32 - 40	167 482 655	0.135	44	72	140	66	75	41	80
- 63	2	- 50	167 482 656	0.175	64	94	165	78	87	46	85
75 - 90	2 1/2 - 3	65 - 80	167 482 657	0.460	85	157	270	64	206		
- 110	4	- 100	167 482 658	0.480	123	175	320	64	256		



Mounting plate 546 PP-GF (L02)

- 2 mounting screws inclusive

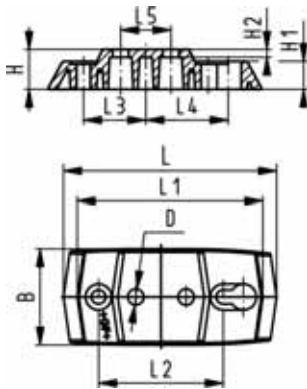

d-d [mm]	Inch [inch]	DN-DN [mm]	Code	kg
16 - 32	¾ - 1	10 - 25	167 484 110	0.054
40 - 63	1 ¼ - 2	32 - 50	167 484 111	0.066

d-d [mm]	B [mm]	D [mm]	H [mm]	H1 [mm]	H2 [mm]	L [mm]	L1 [mm]	L2 [mm]	L3 [mm]	L4 [mm]	L5 [mm]
16 - 32	48	8	20	14	4	106	92	62	31	41	25
40 - 63	54	9	20	14	4	149	134	104	52	62	45

Handle extension 546 PVC-U metric

Model:

- For ball valve type 546 and 543
- Composed of adapter sockets for handle connection and stem connection
- PVC-U pipe in suitable length has to be obtained on site



d-d [mm]	DN-DN [mm]	Code	kg	H [mm]	H1 [mm]	H2 [mm]	H3 [mm]	D [mm]
16 - 20	10 - 15	161 486 435	0.030	41	52	29	36	26
25 - 32	20 - 25	161 486 436	0.029	50	62	32	39	36
40 - 50	32 - 40	161 486 437	0.045	65	76	34	44	40
- 63	- 50	161 486 438	0.059	84	87	37	48	44

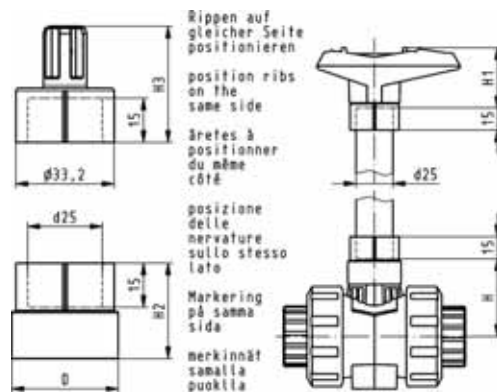

Ball Valves 523

PROGEF Standard Metering ball valve type 523 With mounting inserts With fusion sockets metric

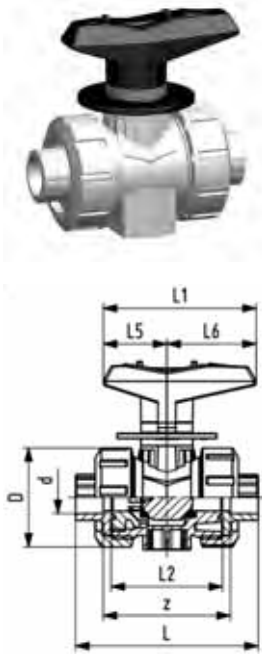

Model:

- Material: PP-H
- Micro-doser
- Excellent control characteristics
- Designed for easy installation and removal
- Angle of operation 180° with scale
- Integrated stainless steel mounting inserts
- Ball seals PTFE
- Z-length, end connectors and union nuts **not compatible** to Type 323

Option:

- Other materials on demand

d [mm]	DN [mm]	PN	kv-value ($\Delta p=1$ bar) [l/min]	EPDM Code	FPM Code	kg
16	10	10	11	167 523 401	167 523 411	0.130
20	15	10	20	167 523 402	167 523 412	0.130

d [mm]	D [mm]	H [mm]	H1 [mm]	L [mm]	L1 [mm]	L2 [mm]	L4 [mm]	L5 [mm]	L6 [mm]	z [mm]
16	50	68	27	93	77	56	25	32	45	67
20	50	68	27	95	77	56	25	32	45	66

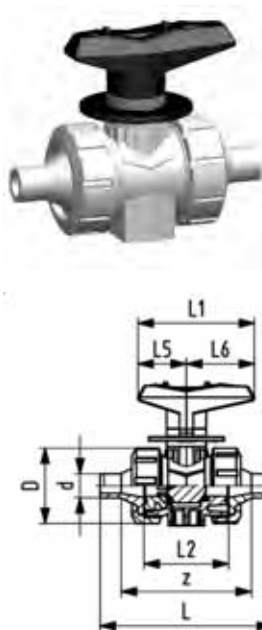

PROGEF Standard Metering ball valve type 523 With mounting inserts With socket fusion spigots metric

Model:

- Material: PP-H
- Micro-doser
- Excellent control characteristics
- Designed for easy installation and removal
- Angle of operation 180° with scale
- Integrated stainless steel mounting inserts
- Ball seals PTFE
- Z-length, end connectors and union nuts **not compatible** to Type 323

Option:

- Other materials on demand

d [mm]	DN [mm]	PN	kv-value ($\Delta p=1$ bar) [l/min]	EPDM Code	FPM Code	kg
16	10	10	11	167 523 441	167 523 451	0.130
20	15	10	20	167 523 442	167 523 452	0.130

d [mm]	D [mm]	H [mm]	H1 [mm]	H2 [mm]	L [mm]	L1 [mm]	L2 [mm]	L3 [mm]	L4 [mm]	L5 [mm]	L6 [mm]	M
16	50	68	27	12	110	77	56		25	32	45	M6
20	50	68	27	12	120	77	56	130	25	32	45	M6

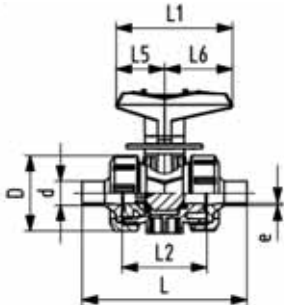

**PROGEF Standard
Metering ball valve type 523
With mounting inserts
With butt fusion spigots IR-Plus SDR11 metric**

Model:

- Material: PP-H
- Micro-doser
- Excellent control characteristics
- Designed for easy installation and removal
- Angle of operation 180° with scale
- Integrated stainless steel mounting inserts
- Ball seals PTFE
- Z-length, end connectors and union nuts **not compatible** to Type 323

Option:

- Other materials on demand

d [mm]	DN [mm]	PN	kv-value ($\Delta p=1$ bar) [l/min]	EPDM Code	FPM Code	kg
20	15	10	11	167 523 482	167 523 492	0.130

d [mm]	D [mm]	H [mm]	H1 [mm]	H2 [mm]	L [mm]	L1 [mm]	L2 [mm]	L4 [mm]	L5 [mm]	L6 [mm]	M	e [mm]
20	50	68	27	12	130	77	56	25	32	45	M6	1.9

Ball Valves 543

PROGEF Standard 3-Way ball valve type 543 Horizontal/L-port With fusion sockets metric

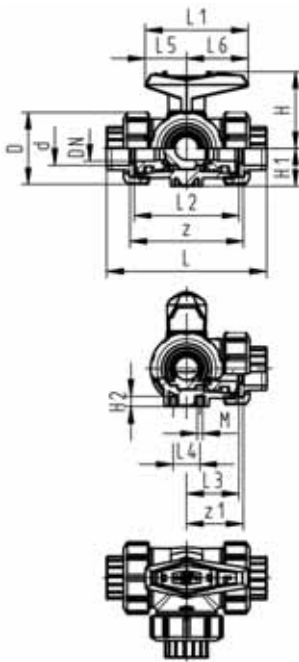
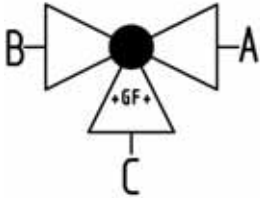

Model:

- Material: PP-H
- For easy installation and removal (valve end and union nut are compatible with type 546)
- Ball seals PTFE
- Pneumatic or electric actuator available separately
- Angle of operation 360° without turn limiter
- Turn limiter 90° enclosed, in different positions usable as a clip-on ring
- Integrated stainless steel mounting inserts
- Delivery status A-C opened, see flow scheme

d [mm]	DN [mm]	PN	kv-value ($\Delta p=1$ bar) [l/min]	EPDM Code	FPM Code	kg
16	10	10	50	167 543 001	167 543 011	0.161
20	15	10	75	167 543 002	167 543 012	0.165
25	20	10	150	167 543 003	167 543 013	0.237
32	25	10	280	167 543 004	167 543 014	0.361
40	32	10	480	167 543 005	167 543 015	0.616
50	40	10	620	167 543 006	167 543 016	0.912
63	50	10	1230	167 543 007	167 543 017	1.882

d [mm]	D [mm]	L [mm]	L1 [mm]	L2 [mm]	L3 [mm]	L4 [mm]	L5 [mm]	L6 [mm]	H [mm]	H1 [mm]	H2 [mm]	M	z [mm]	z1 [mm]
16	50	110	77	72	36	25	32	45	57	28	8	6	82	41
20	50	112	77	72	36	25	32	45	57	28	8	6	82	41
25	58	129	97	85	43	25	39	58	67	32	8	6	97	49
32	68	146	97	98	49	25	39	58	73	36	8	6	110	55
40	84	170	128	118	59	45	54	74	90	45	9	8	132	66
50	97	193	128	135	68	45	54	74	97	51	9	8	151	76
63	124	244	152	176	88	45	66	87	116	65	9	8	188	94



PROGEF Standard 3-Way ball valve type 543 Horizontal/L-port With threaded sockets reinforced Rp

Model:

- Material: PP-H
- For easy installation and removal (valve end and union nut are compatible with type 546)
- Ball seals PTFE
- Pneumatic or electric actuator available separately
- Angle of operation 360° without turn limiter
- Turn limiter 90° enclosed, in different positions usable as a clip-on ring
- Integrated stainless steel mounting inserts
- Delivery status A-C opened, see flow scheme

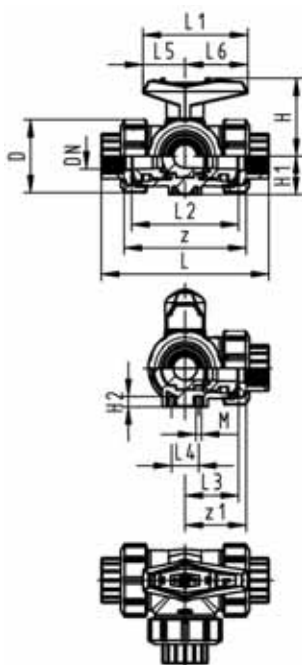
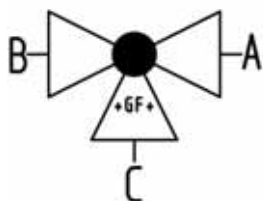

Rp [inch]	DN [mm]	PN	kv-value ($\Delta p=1$ bar) [l/min]	EPDM Code	FPM Code	kg
3/8	10	10	50	167 543 081	167 543 091	0.161
1/2	15	10	75	167 543 082	167 543 092	0.165
3/4	20	10	150	167 543 083	167 543 093	0.237
1	25	10	280	167 543 084	167 543 094	0.361
1 1/4	32	10	480	167 543 085	167 543 095	0.616
1 1/2	40	10	620	167 543 086	167 543 096	0.912
2	50	10	1230	167 543 087	167 543 097	1.773

Rp [inch]	D [mm]	L [mm]	L1 [mm]	L2 [mm]	L3 [mm]	L4 [mm]	L5 [mm]	L6 [mm]	H [mm]	H1 [mm]	H2 [mm]	M	z [mm]	z1 [mm]
3/8	50	112	77	72	36	25	32	45	57	28	8	6	86	43
1/2	50	114	77	72	36	25	32	45	57	28	8	6	84	42
3/4	58	131	97	85	43	25	39	58	67	32	8	6	99	50
1	68	154	97	98	49	25	39	58	73	36	8	6	112	56
1 1/4	84	180	128	118	59	45	54	74	90	45	9	8	132	66
1 1/2	97	203	128	135	68	45	54	74	97	51	9	8	153	77
2	124	258	152	176	88	45	66	87	116	65	9	8	196	98



PROGEF Standard 3-Way ball valve type 543 Horizontal/L-port With socket fusion spigots metric

Model:

- Material: PP-H
- For easy installation and removal (valve end and union nut are compatible with type 546)
- Ball seals PTFE
- Pneumatic or electric actuator available separately
- Angle of operation 360° without turn limiter
- Turn limiter 90° enclosed, in different positions usable as a clip-on ring
- Integrated stainless steel mounting inserts
- Delivery status A-C opened, see flow scheme

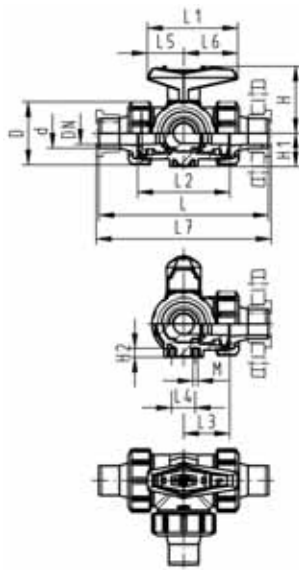
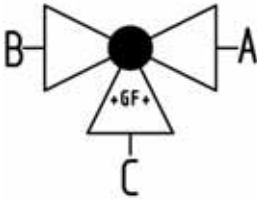

d [mm]	DN [mm]	PN	kv-value ($\Delta p=1$ bar) [l/min]	EPDM Code	FPM Code	kg
16	10	10	50	167 543 021	167 543 031	0.165
20	15	10	75	167 543 022	167 543 032	0.171
25	20	10	150	167 543 023	167 543 033	0.247
32	25	10	280	167 543 024	167 543 034	0.377
40	32	10	480	167 543 025	167 543 035	0.629
50	40	10	620	167 543 026	167 543 036	0.953
63	50	10	1230	167 543 027	167 543 037	1.855

d [mm]	D [mm]	L [mm]	L1 [mm]	L2 [mm]	L3 [mm]	L4 [mm]	L5 [mm]	L6 [mm]	L7 [mm]	H [mm]	H1 [mm]	H2 [mm]	M
16	50	126	77	72	36	25	32	45	133	57	28	8	6
20	50	136	77	72	36	25	32	45	144	57	28	8	6
25	58	159	97	85	43	25	39	58	170	67	32	8	6
32	68	178	97	98	49	25	39	58	191	73	36	8	6
40	84	204	128	118	59	45	54	74	223	90	45	9	8
50	97	237	128	135	68	45	54	74	256	97	51	9	8
63	124	296	152	176	88	45	66	87	319	116	65	9	8



PROGEF Standard
3-Way ball valve type 543
Horizontal/L-port
With butt fusion spigots IR-Plus
SDR11 metric

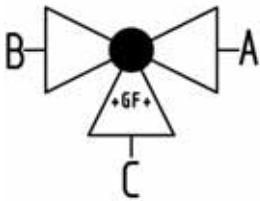

Model:

- Material: PP-H
- For easy installation and removal (valve end and union nut are compatible with type 546)
- Ball seals PTFE
- Pneumatic or electric actuator available separately
- Angle of operation 360° without turn limiter
- Turn limiter 90° enclosed, in different positions usable as a clip-on ring
- Integrated stainless steel mounting inserts
- Delivery status A-C opened, see flow scheme

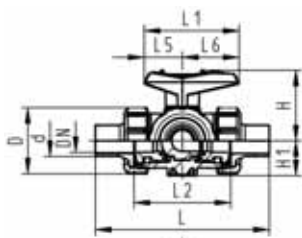

d [mm]	DN [mm]	PN	kv-value ($\Delta p=1$ bar) [l/min]	EPDM Code	FPM Code	kg
20	15	10	75	167 543 062	167 543 072	0.171
25	20	10	150	167 543 063	167 543 073	0.247
32	25	10	280	167 543 064	167 543 074	0.377
40	32	10	480	167 543 065	167 543 075	0.629
50	40	10	620	167 543 066	167 543 076	0.953
63	50	10	1230	167 543 067	167 543 077	1.855

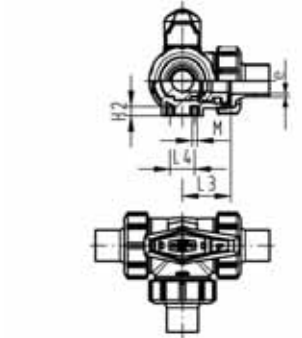

d [mm]	D [mm]	L [mm]	L1 [mm]	L2 [mm]	L3 [mm]	L4 [mm]	L5 [mm]	L6 [mm]	H [mm]	H1 [mm]	H2 [mm]	M [mm]	e [mm]
20	50	146	77	72	36	25	32	45	57	28	8	6	1.9
25	58	163	97	85	43	25	39	58	67	32	8	6	2.3
32	68	178	97	98	49	25	39	58	73	36	8	6	2.9
40	84	204	128	118	59	45	54	74	90	45	9	8	3.7
50	97	237	128	135	68	45	54	74	97	51	9	8	4.6
63	124	296	152	176	88	45	66	87	116	65	9	8	5.8



**PROGEF Standard
3-Way ball valve type 543
Horizontal/L-port
With butt fusion spigots long
SDR11 metric**

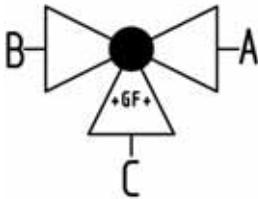

Model:

- Material: PP-H
- For easy installation and removal (valve end and union nut are compatible with type 546)
- Ball seals PTFE
- Pneumatic or electric actuator available separately
- Angle of operation 360° without turn limiter
- Turn limiter 90° enclosed, in different positions usable as a clip-on ring
- Integrated stainless steel mounting inserts
- Delivery status A-C opened, see flow scheme

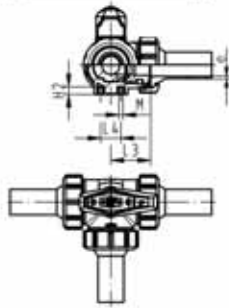
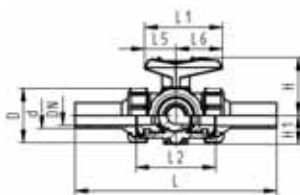

d [mm]	DN [mm]	PN	kv-value ($\Delta p=1$ bar) [l/min]	EPDM Code	FPM Code	kg
20	15	10	75	167 543 102	167 543 112	0.179
25	20	10	150	167 543 103	167 543 113	0.262
32	25	10	280	167 543 104	167 543 114	0.399
40	32	10	480	167 543 105	167 543 115	0.675
50	40	10	620	167 543 106	167 543 116	1.032
63	50	10	1230	167 543 107	167 543 117	2.221

d [mm]	D [mm]	L [mm]	L1 [mm]	L2 [mm]	L3 [mm]	L4 [mm]	L5 [mm]	L6 [mm]	H [mm]	H1 [mm]	H2 [mm]	M [mm]	e [mm]
20	50	210	77	72	36	25	32	45	57	28	8	6	2.3
25	58	237	97	85	43	25	39	58	67	32	8	6	2.3
32	68	250	97	98	49	25	39	58	73	36	8	6	2.9
40	84	282	128	118	59	45	54	74	90	45	9	8	3.7
50	97	317	128	135	68	45	54	74	97	51	9	8	4.6
63	124	396	152	176	88	45	66	87	116	65	9	8	5.8



PROGEF Standard
3-Way ball valve type 543
Horizontal/L-port
With butt fusion spigots long
PE100 SDR11 metric

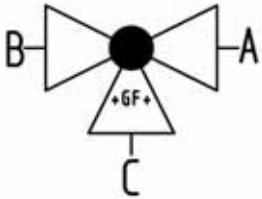

Model:

- Material: PP-H
- For easy installation and removal (valve end and union nut are compatible with type 546)
- Ball seals PTFE
- Pneumatic or electric actuator available separately
- Angle of operation 360° without turn limiter
- Turn limiter 90° enclosed, in different positions usable as a clip-on ring
- Integrated stainless steel mounting inserts
- Delivery status A-C opened, see flow scheme

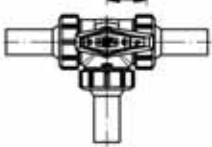
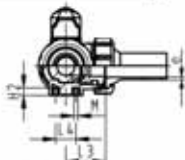
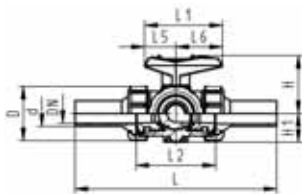

d [mm]	DN [mm]	PN	kv-value ($\Delta p=1$ bar) [l/min]	EPDM Code	FPM Code	kg
20	15	10	75	167 543 122	167 543 132	0.179
25	20	10	150	167 543 123	167 543 133	0.262
32	25	10	280	167 543 124	167 543 134	0.399
40	32	10	480	167 543 125	167 543 135	0.675
50	40	10	620	167 543 126	167 543 136	1.032
63	50	10	1230	167 543 127	167 543 137	2.221

d [mm]	D [mm]	L [mm]	L1 [mm]	L2 [mm]	L3 [mm]	L4 [mm]	L5 [mm]	L6 [mm]	H [mm]	H1 [mm]	H2 [mm]	M	e [mm]
20	50	210	77	72	36	25	32	45	57	28	8	6	2.3
25	58	237	97	85	43	25	39	58	67	32	8	6	2.3
32	68	250	97	98	49	25	39	58	73	36	8	6	2.9
40	84	282	128	118	59	45	54	74	90	45	9	8	3.7
50	97	317	128	135	68	45	54	74	97	51	9	8	4.6
63	124	396	152	176	88	45	66	87	116	65	9	8	5.8



PROGEF Standard 3-Way ball valve type 543 Horizontal/T-port With fusion sockets metric

Model:

- Material: PP-H
- For easy installation and removal (valve end and union nut are compatible with type 546)
- Ball seals PTFE
- Pneumatic or electric actuator available separately
- Angle of operation 360° without turn limiter
- Turn limiter 90° enclosed, in different positions usable as a clip-on ring
- Integrated stainless steel mounting inserts
- Delivery status A-B-C opened, see flow scheme

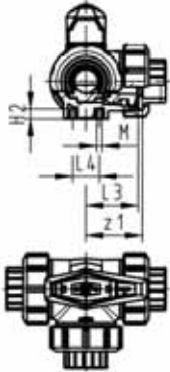
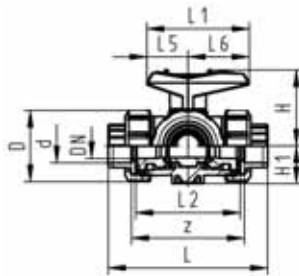
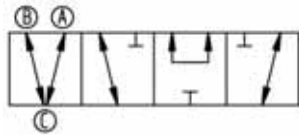
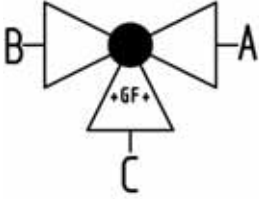

d [mm]	DN [mm]	PN	kv-value ($\Delta p=1$ bar) [l/min]	EPDM Code	FPM Code	kg
16	10	10	140	167 543 201	167 543 211	0.160
20	15	10	200	167 543 202	167 543 212	0.164
25	20	10	470	167 543 203	167 543 213	0.236
32	25	10	793	167 543 204	167 543 214	0.357
40	32	10	1290	167 543 205	167 543 215	0.609
50	40	10	1910	167 543 206	167 543 216	0.898
63	50	10	3100	167 543 207	167 543 217	1.857

d [mm]	D [mm]	L [mm]	L1 [mm]	L2 [mm]	L3 [mm]	L4 [mm]	L5 [mm]	L6 [mm]	H [mm]	H1 [mm]	H2 [mm]	M	z [mm]	z1 [mm]
16	50	110	77	72	36	25	32	45	57	28	8	6	82	41
20	50	112	77	72	36	25	32	45	57	28	8	6	82	41
25	58	129	97	85	43	25	39	58	67	32	8	6	97	49
32	68	146	97	98	49	25	39	58	73	36	8	6	110	55
40	84	170	128	118	59	45	54	74	90	45	9	8	132	66
50	97	193	128	135	68	45	54	74	97	51	9	8	151	76
63	124	244	152	176	88	45	66	87	116	65	9	8	188	94



PROGEF Standard 3-Way ball valve type 543 Horizontal/T-port With threaded sockets reinforced Rp

Model:

- Material: PP-H
- For easy installation and removal (valve end and union nut are compatible with type 546)
- Ball seals PTFE
- Pneumatic or electric actuator available separately
- Angle of operation 360° without turn limiter
- Turn limiter 90° enclosed, in different positions usable as a clip-on ring
- Integrated stainless steel mounting inserts
- Delivery status A-B-C opened, see flow scheme

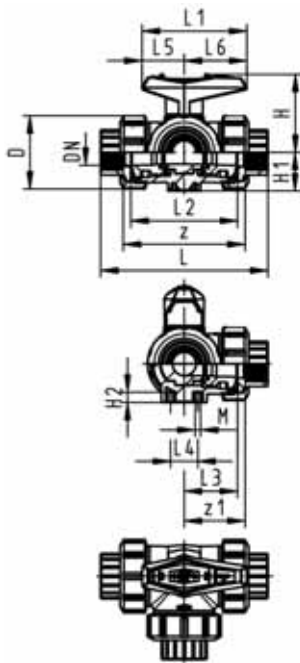
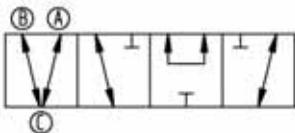
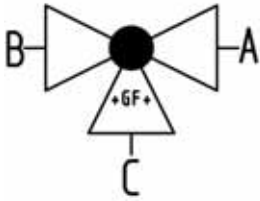

Rp [inch]	DN [mm]	PN	kv-value ($\Delta p=1$ bar) [l/min]	EPDM Code	FPM Code	kg
3/8	10	10	140	167 543 281	167 543 291	0.160
1/2	15	10	200	167 543 282	167 543 292	0.164
3/4	20	10	470	167 543 283	167 543 293	0.236
1	25	10	793	167 543 284	167 543 294	0.357
1 1/4	32	10	1290	167 543 285	167 543 295	0.609
1 1/2	40	10	1910	167 543 286	167 543 296	0.898
2	50	10	3100	167 543 287	167 543 297	1.744

Rp [inch]	D [mm]	L [mm]	L1 [mm]	L2 [mm]	L3 [mm]	L4 [mm]	L5 [mm]	L6 [mm]	H [mm]	H1 [mm]	H2 [mm]	M	z [mm]	z1 [mm]
3/8	50	112	77	72	36	25	32	45	57	28	8	6	86	43
1/2	50	114	77	72	36	25	32	45	57	28	8	6	84	42
3/4	58	131	97	85	43	25	39	58	67	32	8	6	99	50
1	68	154	97	98	49	25	39	58	73	36	8	6	112	56
1 1/4	84	180	128	118	59	45	54	74	90	45	9	8	132	66
1 1/2	97	203	128	135	68	45	54	74	97	51	9	8	153	77
2	124	258	152	176	88	45	66	87	116	65	9	8	196	98



PROGEF Standard 3-Way ball valve type 543 Horizontal/T-port With socket fusion spigots metric

Model:

- Material: PP-H
- For easy installation and removal (valve end and union nut are compatible with type 546)
- Ball seals PTFE
- Pneumatic or electric actuator available separately
- Angle of operation 360° without turn limiter
- Turn limiter 90° enclosed, in different positions usable as a clip-on ring
- Integrated stainless steel mounting inserts
- Delivery status A-B-C opened, see flow scheme

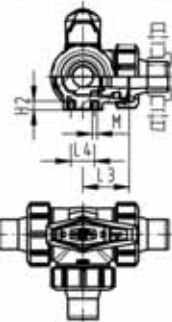
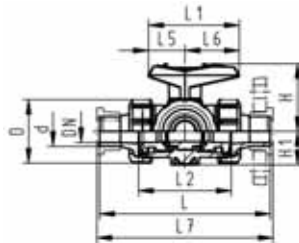
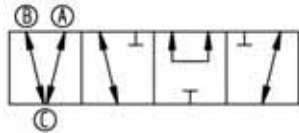
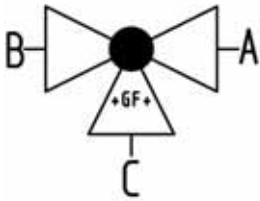

d [mm]	DN [mm]	PN	kv-value ($\Delta p=1$ bar) [l/min]	EPDM Code	FPM Code	kg
16	10	10	140	167 543 221	167 543 231	0.164
20	15	10	200	167 543 222	167 543 232	0.170
25	20	10	470	167 543 223	167 543 233	0.245
32	25	10	793	167 543 224	167 543 234	0.372
40	32	10	1290	167 543 225	167 543 235	0.622
50	40	10	1910	167 543 226	167 543 236	0.939
63	50	10	3100	167 543 227	167 543 237	1.826

d [mm]	D [mm]	L [mm]	L1 [mm]	L2 [mm]	L3 [mm]	L4 [mm]	L5 [mm]	L6 [mm]	L7 [mm]	H [mm]	H1 [mm]	H2 [mm]	M
16	50	126	77	72	36	25	32	45	133	57	28	8	6
20	50	136	77	72	36	25	32	45	144	57	28	8	6
25	58	159	97	85	43	25	39	58	170	67	32	8	6
32	68	178	97	98	49	25	39	58	191	73	36	8	6
40	84	204	128	118	59	45	54	74	223	90	45	9	8
50	97	237	128	135	68	45	54	74	256	97	51	9	8
63	124	296	152	176	88	45	66	87	319	116	65	9	8



PROGEF Standard
3-Way ball valve type 543
Horizontal/T-port
With butt fusion spigots IR-Plus
SDR11 metric

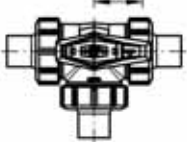
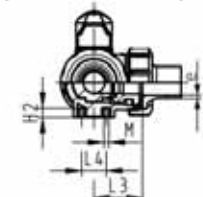
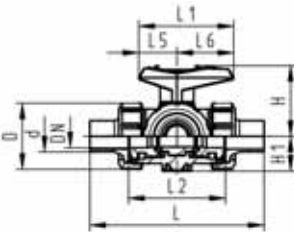
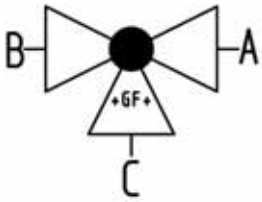

Model:

- Material: PP-H
- For easy installation and removal (valve end and union nut are compatible with type 546)
- Ball seals PTFE
- Pneumatic or electric actuator available separately
- Angle of operation 360° without turn limiter
- Turn limiter 90° enclosed, in different positions usable as a clip-on ring
- Integrated stainless steel mounting inserts
- Delivery status A-B-C opened, see flow scheme

d [mm]	DN [mm]	PN	kv-value ($\Delta p=1$ bar) [l/min]	EPDM Code	FPM Code	kg
20	15	10	200	167 543 262	167 543 272	0.170
25	20	10	470	167 543 263	167 543 273	0.245
32	25	10	793	167 543 264	167 543 274	0.372
40	32	10	1290	167 543 265	167 543 275	0.622
50	40	10	1910	167 543 266	167 543 276	0.939
63	50	10	3100	167 543 267	167 543 277	1.826

d [mm]	D [mm]	L [mm]	L1 [mm]	L2 [mm]	L3 [mm]	L4 [mm]	L5 [mm]	L6 [mm]	H [mm]	H1 [mm]	H2 [mm]	M	e [mm]
20	50	146	77	72	36	25	32	45	57	28	8	6	1.9
25	58	163	97	85	43	25	39	58	67	32	8	6	2.3
32	68	178	97	98	49	25	39	58	73	36	8	6	2.9
40	84	204	128	118	59	45	54	74	90	45	9	8	3.7
50	97	237	128	135	68	45	54	74	97	51	9	8	4.6
63	124	296	152	176	88	45	66	87	116	65	9	8	5.8



**PROGEF Standard
3-Way ball valve type 543
Horizontal/T-port
With butt fusion spigots long
SDR11 metric**

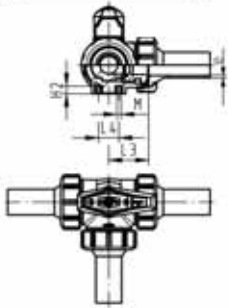
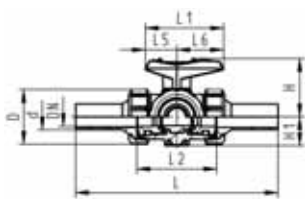
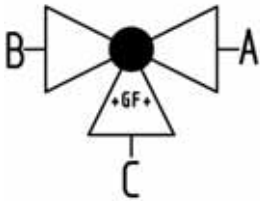

Model:

- Material: PP-H
- For easy installation and removal (valve end and union nut are compatible with type 546)
- Ball seals PTFE
- Pneumatic or electric actuator available separately
- Angle of operation 360° without turn limiter
- Turn limiter 90° enclosed, in different positions usable as a clip-on ring
- Integrated stainless steel mounting inserts
- Delivery status A-B-C opened, see flow scheme

d [mm]	DN [mm]	PN	kv-value ($\Delta p=1$ bar) [l/min]	EPDM Code	FPM Code	kg
20	15	10	200	167 543 302	167 543 312	1.744
25	20	10	470	167 543 303	167 543 313	0.160
32	25	10	793	167 543 304	167 543 314	0.164
40	32	10	1290	167 543 305	167 543 315	0.236
50	40	10	1910	167 543 306	167 543 316	0.357
63	50	10	3100	167 543 307	167 543 317	0.609

d [mm]	D [mm]	L [mm]	L1 [mm]	L2 [mm]	L3 [mm]	L4 [mm]	L5 [mm]	L6 [mm]	H [mm]	H1 [mm]	H2 [mm]	M	e [mm]
20	50	210	77	72	36	25	32	45	57	28	8	6	2.3
25	58	237	97	85	43	25	39	58	67	32	8	6	2.3
32	68	250	97	98	49	25	39	58	73	36	8	6	2.9
40	84	282	128	118	59	45	54	74	90	45	9	8	3.7
50	97	317	128	135	68	45	54	74	97	51	9	8	4.6
63	124	396	152	176	88	45	66	87	116	65	9	8	5.8



PROGEF Standard
3-Way ball valve type 543
Horizontal/T-port
With butt fusion spigots long
PE100 SDR11 metric

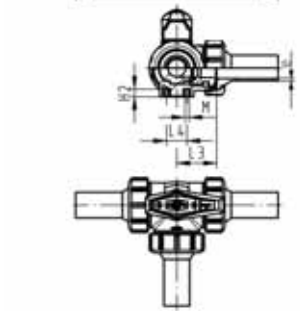
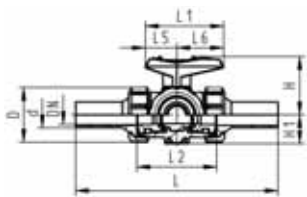
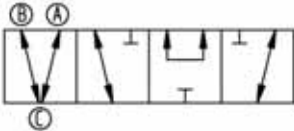
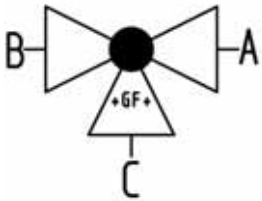

Model:

- Material: PP-H
- For easy installation and removal (valve end and union nut are compatible with type 546)
- Ball seals PTFE
- Pneumatic or electric actuator available separately
- Angle of operation 360° without turn limiter
- Turn limiter 90° enclosed, in different positions usable as a clip-on ring
- Integrated stainless steel mounting inserts
- Delivery status A-B-C opened, see flow scheme

d [mm]	DN [mm]	PN	kv-value ($\Delta p=1$ bar) [l/min]	EPDM Code	FPM Code	kg
20	15	10	200	167 543 322	167 543 332	0.179
25	20	10	470	167 543 323	167 543 333	0.261
32	25	10	793	167 543 324	167 543 334	0.395
40	32	10	1290	167 543 325	167 543 335	0.668
50	40	10	1910	167 543 326	167 543 336	1.019
63	50	10	3100	167 543 327	167 543 337	2.192

d [mm]	D [mm]	L [mm]	L1 [mm]	L2 [mm]	L3 [mm]	L4 [mm]	L5 [mm]	L6 [mm]	H [mm]	H1 [mm]	H2 [mm]	M [mm]	e [mm]
20	50	210	77	72	36	25	32	45	57	28	8	6	2.3
25	58	237	97	85	43	25	39	58	67	32	8	6	2.3
32	68	250	97	98	49	25	39	58	73	36	8	6	2.9
40	84	282	128	118	59	45	54	74	90	45	9	8	3.7
50	97	317	128	135	68	45	54	74	97	51	9	8	4.6
63	124	396	152	176	88	45	66	87	116	65	9	8	5.8



PROGEF Standard
3-Way ball valve type 543
Horizontal/L-port
With lockable handle
With fusion sockets metric

Model:

- Material: PP-H
- For easy installation and removal (valve end and union nut are compatible with type 546)
- Ball seals PTFE
- Pneumatic or electric actuator available separately
- Angle of operation 360° without turn limiter
- Turn limiter 90° enclosed, in different positions usable as a clip-on ring
- Integrated stainless steel mounting inserts
- Multifunctional lever red with ratched setting 45°, lockable
- Delivery status A-C opened, see flow scheme

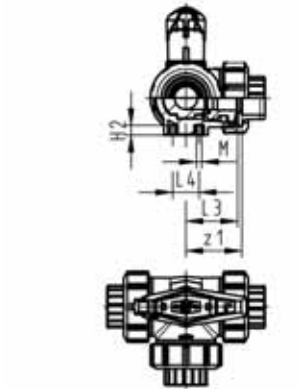
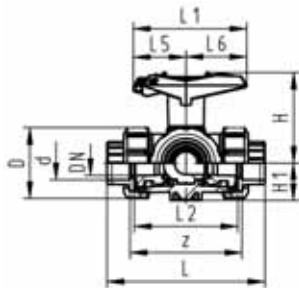
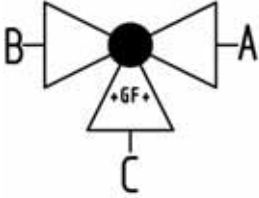

d [mm]	DN [mm]	PN	kv-value ($\Delta p=1$ bar) [l/min]	EPDM Code	FPM Code	kg
16	10	10	50	167 543 561	167 543 571	0.170
20	15	10	75	167 543 562	167 543 572	0.174
25	20	10	150	167 543 563	167 543 573	0.248
32	25	10	280	167 543 564	167 543 574	0.372
40	32	10	480	167 543 565	167 543 575	0.631
50	40	10	620	167 543 566	167 543 576	0.927
63	50	10	1230	167 543 567	167 543 577	1.793

d [mm]	D [mm]	L [mm]	L1 [mm]	L2 [mm]	L3 [mm]	L4 [mm]	L5 [mm]	L6 [mm]	H [mm]	H1 [mm]	H2 [mm]	M	z [mm]	z1 [mm]
16	50	110	87	72	36	25	42	45	79	28	8	6	82	41
20	50	112	87	72	36	25	42	45	79	28	8	6	82	41
25	58	129	108	85	43	25	50	58	88	32	8	6	97	49
32	68	146	108	98	49	25	50	58	94	36	8	6	110	55
40	84	170	141	118	59	45	66	75	113	45	9	8	132	66
50	97	193	141	135	68	45	66	75	119	51	9	8	151	76
63	124	244	165	176	88	45	78	87	141	65	9	8	188	94



PROGEF Standard
3-Way ball valve type 543
Horizontal/L-port
With lockable handle
With butt fusion spigots IR-Plus
SDR11 metric

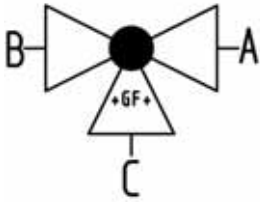

Model:

- Material: PP-H
- For easy installation and removal (valve end and union nut are compatible with type 546)
- Ball seals PTFE
- Pneumatic or electric actuator available separately
- Angle of operation 360° without turn limiter
- Turn limiter 90° enclosed, in different positions usable as a clip-on ring
- Integrated stainless steel mounting inserts
- Multifunctional lever red with ratched setting 45°, lockable
- Delivery status A-C opened, see flow scheme

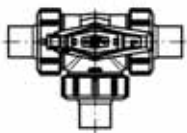
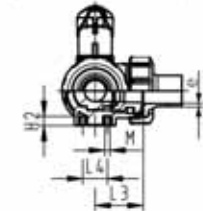
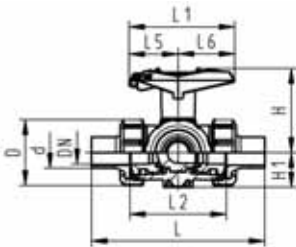

d [mm]	DN [mm]	PN	kv-value ($\Delta p=1$ bar) [l/min]	EPDM Code	FPM Code	kg
20	15	10	75	167 543 602	167 543 612	0.180
25	20	10	150	167 543 603	167 543 613	0.258
32	25	10	280	167 543 604	167 543 614	0.396
40	32	10	480	167 543 605	167 543 615	0.645
50	40	10	620	167 543 606	167 543 616	0.968
63	50	10	1230	167 543 607	167 543 617	1.876

d [mm]	D [mm]	L [mm]	L1 [mm]	L2 [mm]	L3 [mm]	L4 [mm]	L5 [mm]	L6 [mm]	H [mm]	H1 [mm]	H2 [mm]	M	e [mm]
20	50	146	87	72	36	25	42	45	79	28	8	6	1.9
25	58	163	108	85	43	25	50	58	88	32	8	6	2.3
32	68	178	108	98	49	25	50	58	94	36	8	6	2.9
40	84	204	141	118	59	45	66	75	113	45	9	8	3.7
50	97	237	141	135	68	45	66	75	119	51	9	8	4.6
63	124	296	165	176	88	45	78	87	141	65	9	8	5.8



PROGEF Standard
3-Way ball valve type 543
Horizontal/T-port
With lockable handle
With fusion sockets metric

Model:

- Material: PP-H
- For easy installation and removal (valve end and union nut are compatible with type 546)
- Ball seals PTFE
- Pneumatic or electric actuator available separately
- Angle of operation 360° without turn limiter
- Turn limiter 90° enclosed, in different positions usable as a clip-on ring
- Integrated stainless steel mounting inserts
- Multifunctional lever red with ratched setting 45°, lockable
- Delivery status A-B-C opened, see flow scheme

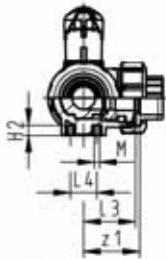
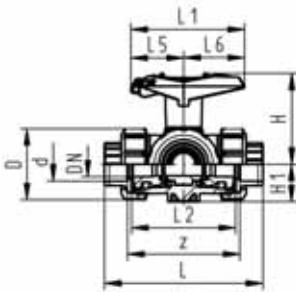
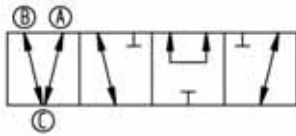
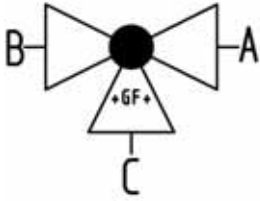

d [mm]	DN [mm]	PN	kv-value ($\Delta p=1$ bar) [l/min]	EPDM Code	FPM Code	kg
16	10	10	140	167 543 581	167 543 591	0.169
20	15	10	200	167 543 582	167 543 592	0.173
25	20	10	470	167 543 583	167 543 593	0.247
32	25	10	793	167 543 584	167 543 594	0.368
40	32	10	1290	167 543 585	167 543 595	0.624
50	40	10	1910	167 543 586	167 543 596	0.913
63	50	10	3100	167 543 587	167 543 597	1.764

d [mm]	D [mm]	L [mm]	L1 [mm]	L2 [mm]	L3 [mm]	L4 [mm]	L5 [mm]	L6 [mm]	H [mm]	H1 [mm]	H2 [mm]	M [mm]	z [mm]	z1 [mm]
16	50	110	87	72	36	25	42	45	79	28	8	6	82	41
20	50	112	87	72	36	25	42	45	79	28	8	6	82	41
25	58	129	108	85	43	25	50	58	88	32	8	6	97	49
32	68	146	108	98	49	25	50	58	94	36	8	6	110	55
40	84	170	141	118	59	45	66	75	113	45	9	8	132	66
50	97	193	141	135	68	45	66	75	119	51	9	8	151	76
63	124	244	165	176	88	45	78	87	141	65	9	8	188	94



PROGEF Standard
3-Way ball valve type 543
Horizontal/T-port
With lockable handle
With butt fusion spigots IR-Plus
SDR11 metric

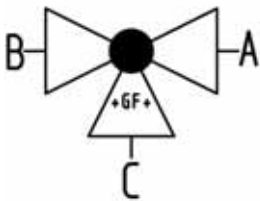

Model:

- Material: PP-H
- For easy installation and removal (valve end and union nut are compatible with type 546)
- Ball seals PTFE
- Pneumatic or electric actuator available separately
- Angle of operation 360° without turn limiter
- Turn limiter 90° enclosed, in different positions usable as a clip-on ring
- Integrated stainless steel mounting inserts
- Multifunctional lever red with ratched setting 45°, lockable
- Delivery status A-B-C opened, see flow scheme

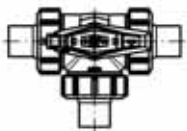
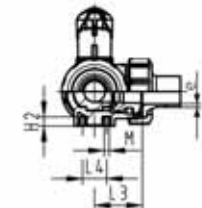
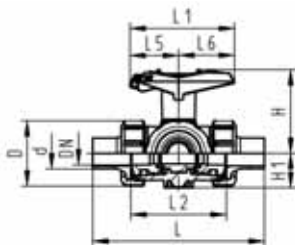

d [mm]	DN [mm]	PN	kv-value ($\Delta p=1$ bar) [l/min]	EPDM Code	FPM Code	kg
20	15	10	200	167 543 622	167 543 632	0.179
25	20	10	470	167 543 623	167 543 633	0.257
32	25	10	793	167 543 624	167 543 634	0.384
40	32	10	1290	167 543 625	167 543 635	0.637
50	40	10	1910	167 543 626	167 543 636	0.954
63	50	10	3100	167 543 627	167 543 637	1.846

d [mm]	D [mm]	L [mm]	L1 [mm]	L2 [mm]	L3 [mm]	L4 [mm]	L5 [mm]	L6 [mm]	H [mm]	H1 [mm]	H2 [mm]	M	e [mm]
20	50	146	87	72	36	25	42	45	79	28	8	6	1.9
25	58	163	108	85	43	25	50	58	88	32	8	6	2.3
32	68	178	108	98	49	25	50	58	94	36	8	6	2.9
40	84	204	141	118	59	45	66	75	113	45	9	8	3.7
50	97	237	141	135	68	45	66	75	119	51	9	8	4.6
63	124	296	165	176	88	45	78	87	141	65	9	8	5.8



Mounting plate 546 and 543 PP-GF (L02)

- 2 mounting screws inclusive

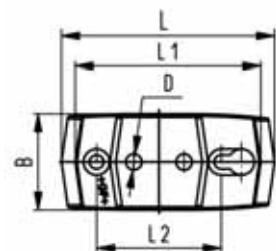
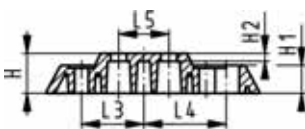

d-d [mm]	Inch [inch]	DN-DN [mm]	Code	kg
16 - 32	3/8 - 1	10 - 25	167 484 110	0.054
40 - 63	1 1/4 - 2	32 - 50	167 484 111	0.066

d-d [mm]	B [mm]	D [mm]	H [mm]	H1 [mm]	H2 [mm]	L [mm]	L1 [mm]	L2 [mm]	L3 [mm]	L4 [mm]	L5 [mm]
16 - 32	48	8	20	14	4	106	92	62	31	41	25
40 - 63	54	9	20	14	4	149	134	104	52	62	45



Handle extension 546 and 543 PVC-U metric

Model:

- For ball valve type 546 and 543
- Composed of adapter sockets for handle connection and stem connection
- PVC-U pipe in suitable length has to be obtained on site

d-d [mm]	DN-DN [mm]	Code	kg	H [mm]	H1 [mm]	H2 [mm]	H3 [mm]	D [mm]
16 - 20	10 - 15	161 486 435	0.030	41	52	29	36	26
25 - 32	20 - 25	161 486 436	0.029	50	62	32	39	36
40 - 50	32 - 40	161 486 437	0.045	65	76	34	44	40
- 63	- 50	161 486 438	0.059	84	87	37	48	44

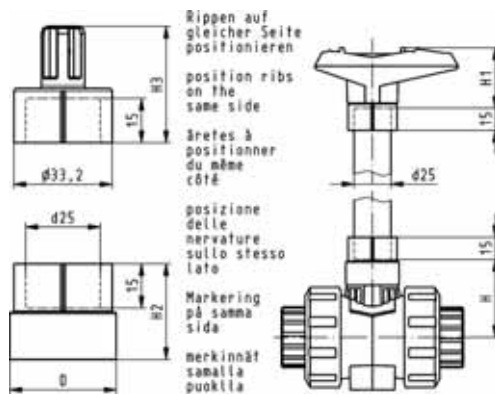

Handle extension 546 PVC-U inch BS/ASTM

Model:

- For Ball Valve Type 546

Includes upper and lower extension adapter, does not include 3/4" pipe

DN-DN [mm]	Inch	Code	kg	H [mm]	H1 [mm]	H2 [mm]	H3 [mm]	D [mm]
10 - 15	3/8-1/2	161 486 443	0.032	41	52	29	36	26
20 - 25	3/4-1	161 486 444	0.030	50	62	32	39	36
32 - 40	1 1/4-1 1/2	161 486 445	0.047	65	76	34	44	40
50 -	2	161 486 446	0.058	84	87	37	48	44

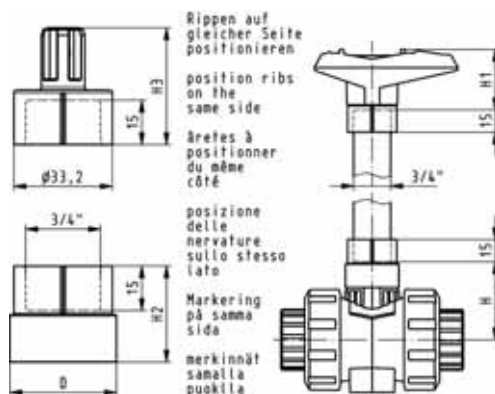

Diaphragm Valves 514

PROGEF Standard Diaphragm valve type 514 With fusion sockets metric

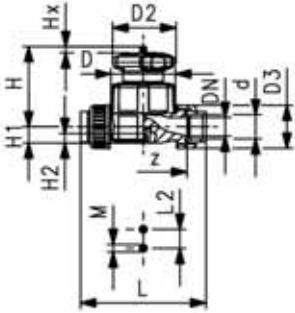

Model:

- Material: PP-H
- Double flow rate compared to predecessor
- One housing nut replaces four screws
- Handwheel with built-in locking mechanism
- For easy installation and removal
- Short overall length

Option:

- Individual configuration of the valve (see diagram)
- Self adjusting multifunctional module with integrated limit switches

d [mm]	DN [mm]	PN	kv-value ($\Delta p=1$ bar) [l/min]	NBR Code	EPDM Code	PTFE/EPDM Code	FPM Code	kg
20	15	10	125	167 514 002	167 514 012	167 514 032	167 514 062	0.267
25	20	10	271	167 514 003	167 514 013	167 514 033	167 514 063	0.391
32	25	10	481	167 514 004	167 514 014	167 514 034	167 514 064	1.080
40	32	10	759	167 514 005	167 514 015	167 514 035	167 514 065	1.277
50	40	10	1263	167 514 006	167 514 016	167 514 036	167 514 066	1.386
63	50	10	1728	167 514 007	167 514 017	167 514 037	167 514 067	3.030

d [mm]	D [mm]	D2 [mm]	D3 [mm]	L [mm]	L2 [mm]	H [mm]	H1 [mm]	H2 [mm]	M	z [mm]	Lift = Hx [mm]
20	65	65	48	128	25	73	14	12	M6	100	7
25	80	65	58	150	25	81	18	12	M6	118	10
32	88	87	65	162	25	107	22	12	M6	126	13
40	101	87	79	184	45	115	26	15	M8	144	15
50	117	135	91	210	45	148	32	15	M8	164	19
63	144	135	111	248	45	166	39	15	M8	194	25

PROGEF Standard Diaphragm valve type 514 With fusion sockets PE80 metric

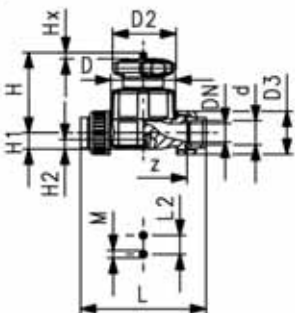

Model:

- Material: PP-H
- Double flow rate compared to predecessor
- One housing nut replaces four screws
- Handwheel with built-in locking mechanism
- For easy installation and removal
- Short overall length

Option:

- Individual configuration of the valve (see diagram)
- Self adjusting multifunctional module with integrated limit switches

d [mm]	DN [mm]	PN	kv-value ($\Delta p=1$ bar) [l/min]	EPDM Code	PTFE/EPDM Code	kg
20	15	10	125	167 514 212	167 514 232	0.371
25	20	10	271	167 514 213	167 514 233	0.501
32	25	10	481	167 514 214	167 514 234	1.103
40	32	10	759	167 514 215	167 514 235	1.299
50	40	10	1263	167 514 216	167 514 236	2.289
63	50	10	1728	167 514 217	167 514 237	2.978

table continued next page

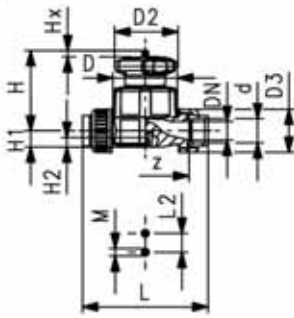

d [mm]	D [mm]	D2 [mm]	D3 [mm]	L [mm]	L2 [mm]	H [mm]	H1 [mm]	H2 [mm]	M	z [mm]	Lift = Hx [mm]
20	65	65	48	128	25	73	14	12	M6	100	7
25	80	65	58	150	25	81	18	12	M6	118	10
32	88	87	65	162	25	107	22	12	M6	126	13
40	101	87	79	184	45	115	26	15	M8	144	15
50	117	135	91	210	45	148	32	15	M8	164	19
63	144	135	111	248	45	166	39	15	M8	194	25



PROGEF Standard Diaphragm valve type 514 With butt fusion spigots SDR11 metric

Model:

- Material: PP-H
- Double flow rate compared to predecessor
- One housing nut replaces four screws
- Handwheel with built-in locking mechanism
- For easy installation and removal
- Short overall length

Option:

- Individual configuration of the valve (see diagram)
- Self adjusting multifunctional module with integrated limit switches

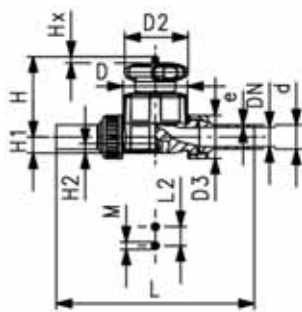

d [mm]	DN [mm]	PN	kv-value ($\Delta p=1$ bar) [l/min]	NBR Code	EPDM Code	PTFE/EPDM Code	FPM Code	kg
20	15	10	125	167 514 102	167 514 112	167 514 132	167 514 162	0.369
25	20	10	271	167 514 103	167 514 113	167 514 133	167 514 163	0.404
32	25	10	481	167 514 104	167 514 114	167 514 134	167 514 164	0.648
40	32	10	759	167 514 105	167 514 115	167 514 135	167 514 165	0.854
50	40	10	1263	167 514 106	167 514 116	167 514 136	167 514 166	2.313
63	50	10	1728	167 514 107	167 514 117	167 514 137	167 514 167	3.044

d [mm]	D [mm]	D2 [mm]	D3 [mm]	L [mm]	L2 [mm]	H [mm]	H1 [mm]	H2 [mm]	M	Lift = Hx [mm]	e [mm]
20	65	65	48	196	25	73	14	12	M6	7	1.9
25	80	65	58	221	25	81	18	12	M6	10	2.3
32	88	87	65	234	25	107	22	12	M6	13	2.9
40	101	87	79	260	45	115	26	15	M8	15	3.7
50	117	135	91	284	45	148	32	15	M8	19	4.6
63	144	135	111	321	45	166	39	15	M8	25	5.8



PROGEF Standard Diaphragm valve type 514 With butt and electro fusion ends PE100 SDR11 metric

Model:

- Material: PP-H
- Double flow rate compared to predecessor
- One housing nut replaces four screws
- Handwheel with built-in locking mechanism
- For easy installation and removal
- Short overall length

Option:

- Individual configuration of the valve (see diagram)
- Self adjusting multifunctional module with integrated limit switches

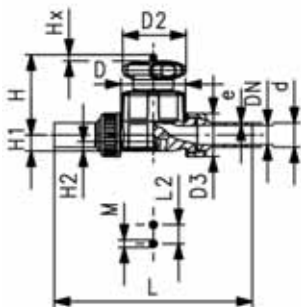

d [mm]	DN [mm]	PN	kv-value ($\Delta p=1$ bar) [l/min]	EPDM Code	PTFE/EPDM Code	kg	
20	15	10	125	167 514 312	167 514 332	0.381	
25	20	10	271	167 514 313	167 514 333	0.513	
32	25	10	481	167 514 314	167 514 334	1.127	
40	32	10	759	167 514 315	167 514 335	1.337	
50	40	10	1263	167 514 316	167 514 336	2.359	
63	50	10	1728	167 514 317	167 514 337	3.088	

d [mm]	D [mm]	D2 [mm]	D3 [mm]	L [mm]	L2 [mm]	H [mm]	H1 [mm]	H2 [mm]	M	Lift = Hx [mm]	e [mm]	
20	65	65	48	196	25	73	14	12	M6	7	1,9	
25	80	65	58	221	25	81	18	12	M6	10	2,3	
32	88	87	65	234	25	107	22	12	M6	13	2,9	
40	101	87	79	260	45	115	26	15	M8	15	3,7	
50	117	135	91	284	45	148	32	15	M8	19	4,6	
63	144	135	111	321	45	166	39	15	M8	25	5,8	

Diaphragm Valves 515

PROGEF Standard

Diaphragm valve type 515

With socket fusion spigots metric

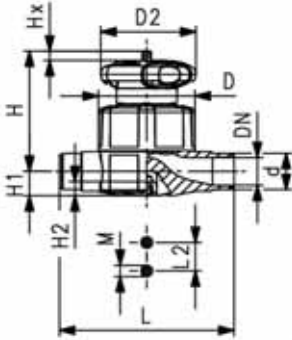

Model:

- Material: PP-H
- Double flow rate compared to predecessor
- One housing nut replaces four screws
- Handwheel with built-in locking mechanism
- Overall length EN 558

Option:

- Individual configuration of the valve (see diagram)
- Self adjusting multifunctional module with integrated limit switches

d [mm]	DN [mm]	PN	kv-value ($\Delta p=1$ bar) [l/min]	NBR Code	EPDM Code	PTFE/EPDM Code	FPM Code	kg
20	15	10	125	167 515 002	167 515 012	167 515 032	167 515 062	0.298
25	20	10	271	167 515 003	167 515 013	167 515 033	167 515 063	0.293
32	25	10	481	167 515 004	167 515 014	167 515 034	167 515 064	0.949
40	32	10	759	167 515 005	167 515 015	167 515 035	167 515 065	1.108
50	40	10	1263	167 515 006	167 515 016	167 515 036	167 515 066	2.057
63	50	10	1728	167 515 007	167 515 017	167 515 037	167 515 067	2.604

d [mm]	D [mm]	D2 [mm]	L [mm]	L2 [mm]	H [mm]	H1 [mm]	H2 [mm]	M	Lift = Hx [mm]	e [mm]
20	65	65	124	25	73	14	12	M6	7	1.9
25	80	65	144	25	81	18	12	M6	10	2.3
32	88	87	154	25	107	22	12	M6	13	2.9
40	101	87	174	45	115	26	15	M8	15	3.7
50	117	135	194	45	148	32	15	M8	19	4.6
63	144	135	223	45	166	39	15	M8	25	5.8



PROGEF Standard Diaphragm valve type 515 With butt fusion spigots SDR11 metric

Model:

- Material: PP-H
- Double flow rate compared to predecessor
- One housing nut replaces four screws
- Handwheel with built-in locking mechanism
- Overall length EN 558

Option:

- Individual configuration of the valve (see diagram)
- Self adjusting multifunctional module with integrated limit switches

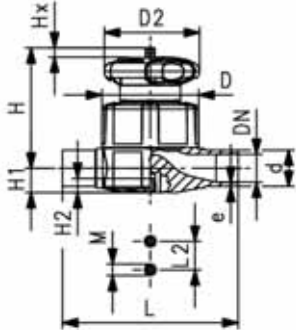

d [mm]	DN [mm]	PN	kv-value ($\Delta p=1$ bar) [l/min]	NBR Code	EPDM Code	PTFE/EPDM Code	FPM Code	kg
20	15	10	125	167 515 102	167 515 112	167 515 132	167 515 162	0.297
25	20	10	271	167 515 103	167 515 113	167 515 133	167 515 163	0.380
32	25	10	481	167 515 104	167 515 114	167 515 134	167 515 164	0.947
40	32	10	759	167 515 105	167 515 115	167 515 135	167 515 165	1.104
50	40	10	1263	167 515 106	167 515 116	167 515 136	167 515 166	2.052
63	50	10	1728	167 515 107	167 515 117	167 515 137	167 515 167	2.601

d [mm]	D [mm]	D2 [mm]	L [mm]	L2 [mm]	H [mm]	H1 [mm]	H2 [mm]	M	Lift = Hx [mm]	e [mm]
20	65	65	124	25	73	14	12	M6	7	1.9
25	80	65	144	25	81	18	12	M6	10	2.3
32	88	87	155	25	107	22	12	M6	13	2.9
40	101	87	176	45	115	26	15	M8	15	3.7
50	117	135	193	45	148	32	15	M8	19	4.6
63	144	135	223	45	166	39	15	M8	25	5.8

Diaphragm Valves 517

PROGEF Standard

Diaphragm valve type 517

With backing flanges PP-V metric/BS

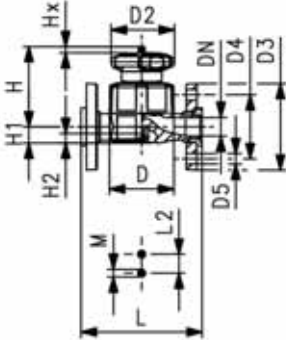

Model:

- Material: PP-H
- Double flow rate compared to predecessor
- One housing nut replaces four screws
- Handwheel with built-in locking mechanism
- Overall length EN 558
- Connecting dimension: ISO 7005 PN 10, EN 1092 PN 10, DIN 2501 PN 10, BS 4504 PN 10
- Flat sealing faces/serrated

Option:

- Individual configuration of the valve (see diagram)
- Self adjusting multifunctional module with integrated limit switches

d [mm]	DN [mm]	PN	kv-value ($\Delta p=1$ bar) [l/min]	NBR Code	EPDM Code	PTFE/EPDM Code	FPM Code	kg
20	15	10	125	167 517 102	167 517 112	167 517 132	167 517 162	0.480
25	20	10	271	167 517 103	167 517 113	167 517 133	167 517 163	0.628
32	25	10	481	167 517 104	167 517 114	167 517 134	167 517 164	1.296
40	32	10	759	167 517 105	167 517 115	167 517 135	167 517 165	1.640
50	40	10	1263	167 517 106	167 517 116	167 517 136	167 517 166	2.601
63	50	10	1728	167 517 107	167 517 117	167 517 137	167 517 167	3.544

d [mm]	D [mm]	D2 [mm]	D3 [mm]	D4 [mm]	D5 [mm]	L [mm]	L2 [mm]	H [mm]	H1 [mm]	H2 [mm]	M	Lift = Hx [mm]
20	65	65	95	65	14	130	25	73	14	12	M6	7
25	80	65	105	75	14	150	25	81	18	12	M6	10
32	88	87	115	85	14	160	25	107	22	12	M6	13
40	101	87	140	100	18	180	45	115	26	15	M8	15
50	117	135	150	110	18	200	45	148	32	15	M8	19
63	144	135	165	125	18	230	45	166	39	15	M8	25



PROGEF Standard Diaphragm valve type 517 With backing flanges PP-V Inch ANSI

Model:

- Material: PP-H
- Double flow rate compared to predecessor
- One housing nut replaces four screws
- Handwheel with built-in locking mechanism
- Overall length EN 558
- Connecting dimension: ANSI/ASME B 16.5 class 150, ASTM D 4024, BS 1560, BS EN 1759
- Flat sealing faces/serrated

Option:

- Individual configuration of the valve (see diagram)
- Self adjusting multifunctional module with integrated limit switches

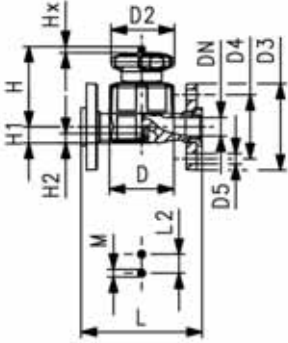

Inch	DN [mm]	PN	kv-value ($\Delta p=1$ bar) [l/min]	EPDM Code	PTFE/EPDM Code	kg
½	15	10	125	167 517 712	167 517 732	0.490
¾	20	10	271	167 517 713	167 517 733	0.640
1	25	10	481	167 517 714	167 517 734	1.316
1 ¼	32	10	759	167 517 715	167 517 735	1.660
1 ½	40	10	1263	167 517 716	167 517 736	2.631
2	50	10	1728	167 517 717	167 517 737	3.572

Inch	D [mm]	D2 [mm]	D3 [mm]	D4 [mm]	D5 [mm]	L [mm]	L2 [mm]	H [mm]	H1 [mm]	H2 [mm]	M	Lift = Hx [mm]
½	65	65	95	60	16	130	25	73	14	12	M6	7
¾	80	65	105	70	16	150	25	81	18	12	M6	10
1	88	87	115	79	16	160	25	107	22	12	M6	13
1 ¼	101	87	140	89	16	180	45	115	26	15	M8	15
1 ½	117	135	150	98	16	200	45	148	32	15	M8	19
2	144	135	165	121	19	230	45	166	39	15	M8	25



PROGEF Standard Diaphragm valve type 317 With backing flanges PP-V Inch ANSI

Model:

- Material: PP-H
- Jointing faces serrated
- With PP-V backing flanges DN 15-65
- Connecting dimensions: ISO 7005 / EN 1092 / DIN 2501 PN10 / BS4504

Option:

- Handwheel with built in locking mechanism
- * With PP fixed flanges, jointing faces flat

Inch	DN [mm]	PN	kv-value ($\Delta p=1$ bar) [l/min]	EPDM Code	PTFE with EPDM supporting di- aphragm Code	NBR Code	kg
2 1/2	65	10	992	167 317 523	167 317 538		4.000
* 3	80	10	1700	167 317 024	167 317 039	167 317 009	7.954
* 4	100	10	2700	167 317 325	167 317 340	167 317 310	11.360
* 6	150	7	6033	167 317 027	167 317 042	167 317 012	25.000

Inch	D [mm]	D1 [mm]	D2 [mm]	D3 [mm]	L [mm]	L1 [mm]	L2 [mm]	L3 [mm]	H [mm]	H1 [mm]	H2 [mm]	M	AL	Lift = Hx [mm]
2 1/2	185	140	152	19	290		70		210	46	15	M8	4	35
* 3	200	160	270	18	310	35	120		265	57	23	M12	8	40
* 4	225	190	270	19	350	38	120		304	69	23	M12	8	50
* 6	282	241	400	23	480	29	100	200	437	108	23	M12	8	70

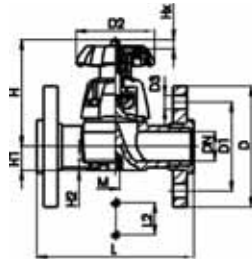

DN 15-65

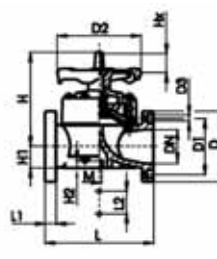

DN 80-100

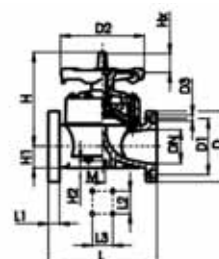

DN 150



PROGEF Standard Diaphragm valve type 517 With fixed flanges PP-H JIS

Model:

- Material: PP-H
- Double flow rate compared to predecessor
- One housing nut replaces four screws
- Handwheel with built-in locking mechanism
- Connecting dimension: JIS B2238/39 10K
- Flat sealing faces/serrated

Option:

- Individual configuration of the valve (see diagram)
- Self adjusting multifunctional module with integrated limit switches

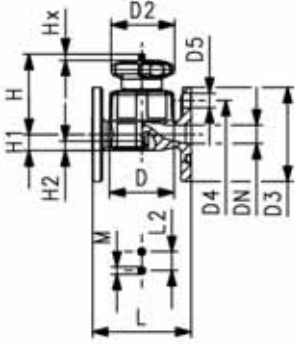

Inch	DN [mm]	PN	kv-value ($\Delta p=1$ bar) [l/min]	EPDM Code	PTFE/EPDM Code	kg
1/2	15	10	125	167 517 912	167 517 932	0.434
3/4	20	10	271	167 517 913	167 517 933	0.514
1	25	10	481	167 517 914	167 517 934	1.168
1 1/4	32	10	759	167 517 915	167 517 935	1.462
1 1/2	40	10	1263	167 517 916	167 517 936	2.449
2	50	10	1728	167 517 917	167 517 937	3.082

Inch	D [mm]	D2 [mm]	D3 [mm]	D4 [mm]	D5 [mm]	L [mm]	L2 [mm]	H [mm]	H1 [mm]	H2 [mm]	M	Lift = Hx [mm]
1/2	65	65	95	70	15	110	25	73	14	12	M6	7
3/4	80	65	100	75	15	120	25	81	18	12	M6	10
1	88	87	125	90	19	130	25	107	22	12	M6	13
1 1/4	101	87	135	100	19	180	45	115	26	15	M8	15
1 1/2	117	135	140	105	19	180	45	148	32	15	M8	19
2	144	135	155	120	19	210	45	166	39	15	M8	25

Diaphragm Valves 519

PROGEF Standard Diaphragm valve type 519 With butt fusion spigots metric



Model:

- Material: PP-H
- Double flow rate compared to predecessor
- One housing nut replaces four screws
- Handwheel with built-in locking mechanism
- Smallest possible dead space

Option:

- Individual configuration of the valve (see diagram)
- Self adjusting multifunctional module with integrated limit switches

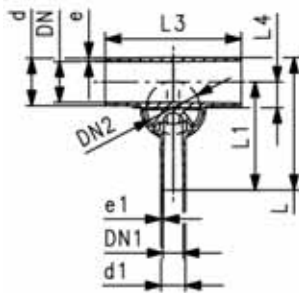
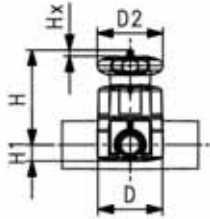

d [mm]	d1 [mm]	Valve Size d [mm]	DN [mm]	DN1 [mm]	DN2 [mm]	PN	kv-value ($\Delta p=1$ bar) [l/min]	EPDM Code	PTFE/EPDM Code	kg
20	20	20	15	15	15	10	57	167 519 101	167 519 301	0.321
25	20	25	20	15	20	10	89	167 519 103	167 519 303	0.397
25	25	25	20	20	20	10	118	167 519 104	167 519 304	0.399
32	20	25	25	15	20	10	80	167 519 107	167 519 307	0.424
32	25	25	25	20	20	10	105	167 519 108	167 519 308	0.426
32	32	32	25	25	25	10	231	167 519 109	167 519 309	0.980
40	20	32	32	15	25	10	85	167 519 112	167 519 312	1.008
50	20	25	40	15	20	10	86	167 519 118	167 519 318	0.485
50	25	32	40	20	25	10	160	167 519 119	167 519 319	1.054
50	32	32	40	25	25	10	206	167 519 120	167 519 320	1.056
63	20	25	50	15	20	10	84	167 519 125	167 519 325	0.524
63	25	32	50	20	25	10	150	167 519 126	167 519 326	1.097
63	32	32	50	25	25	10	184	167 519 127	167 519 327	1.100

d [mm]	D [mm]	D2 [mm]	L [mm]	L1 [mm]	L3 [mm]	L4 [mm]	H [mm]	Lift = Hx [mm]	e [mm]	e1 [mm]
20	65	65	117	96	162	12	75	7	1.9	1.9
25	80	65	133	108	162	16	80	10	2.3	1.9
25	80	65	133	108	162	16	80	10	2.3	2.3
32	80	65	142	120	162	19	84	10	2.9	1.9
32	80	65	142	120	162	19	84	10	2.9	2.3
32	88	87	145	120	160	19	107	13	2.9	2.9
40	88	87	149	128	180	23	115	13	3.7	1.9
50	80	65	160	134	180	27	97	10	4.6	1.9
50	88	87	160	134	180	28	120	13	4.6	2.3
50	88	87	160	134	180	28	120	13	4.6	2.9
63	80	65	177	144	180	33	104	10	5.8	1.9
63	88	87	177	144	180	35	127	13	5.8	2.3
63	88	87	177	144	180	35	127	13	5.8	2.9

Electrical feedback module I40/I41 With limit switches Ag Ni or AU



Model:

- Accessory to hand operated diaphragm valve 514 - 519
- No height increase
- Easy, fast and safe installation
- Self adjusting mechanism
- Including Plug 3P+E / Protection: IP65

d-d [mm]	DN-DN [mm]	Size	Ag Ni Code	AU Code	kg
10 - 25	10 - 20	1	198 151 335	198 151 336	0.120
32 - 40	25 - 32	2	198 151 337	198 151 338	0.101
50 - 63	40 - 50	3	198 151 339	198 151 340	0.120

Butterfly valves

PROGEF Standard

Butterfly valve type 567

Hand lever with ratchet settings



Model:

- Material: PP-H, DN350-DN600 material PP-R
- Connecting dimension: ISO 7005 PN 10, EN 1092 PN 10, DIN 2501 PN 10, ANSI/ASME B 16.5 Class 150, BS 1560: 1989, BS 4504, JIS B 2220
- Up to DN 300: Overall length according to EN558 (DN 50-200: line 25, DN250, 300 line 16), ISO 5752
- We recommend for the dimensions DN250 and DN300 only 6 bar maximum system pressure for the hand lever version

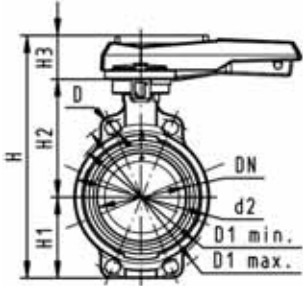

d [mm]	DN [mm]	Inch	PN	kv-value ($\Delta p=1$ bar) [l/min]	EPDM Code	FPM Code	PTFE Code	kg
63	50	2	10	1470	167 567 002	167 567 022	167 567 202	1.170
75	65	2 ½	10	2200	167 567 003	167 567 023	167 567 203	1.254
90	80	3	10	3000	167 567 004	167 567 024	167 567 204	1.384
110	100	4	10	6500	167 567 005	167 567 025	167 567 205	1.961
140	125	5	10	11500	167 567 006	167 567 026	167 567 206	2.367
160	150	6	10	16600	167 567 007	167 567 027	167 567 207	3.741
225	200	8	10	39600	167 567 008	167 567 028	167 567 208	5.545
280	250	10	8	55200	167 567 009	167 567 029	167 567 209	11.061
315	300	12	8	80000	167 567 010	167 567 030	167 567 210	16.548

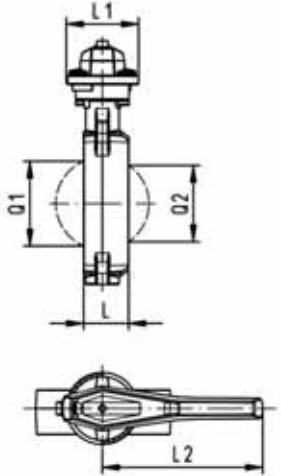

d [mm]	D [mm]	D1 min. [mm]	D1 max. [mm]	d2 [mm]	H [mm]	H1 [mm]	H2 [mm]	H3 [mm]	L [mm]	L1 [mm]	L2 [mm]	Q1 [mm]	Q2 [mm]
63	19	120.0	125.0	104	264	77	134	54	45	106	205	40	
75	19	139.7	145.0	115	277	83	140	54	46	106	205	54	35
90	19	150.0	160.0	131	289	89	146	54	49	106	205	67	50
110	19	175.0	190.5	161	325	104	167	55	56	106	255	88	74
140	23	210.0	215.9	187	352	117	181	55	64	106	255	113	97
160	24	241.3	241.3	215	373	130	189	55	72	106	255	139	123
225	23	290.0	295.0	267	435	158	210	67	73	140	408	178	169
280	25	353.0	362.0	329	554	205	264	85	113	149	408	210	207
315	25	400.0	432.0	379	598	228	285	85	113	149	408	256	253



PROGEF Standard Butterfly valve type 567 Reduction gear with handwheel

Model:

- Material: PP-H, DN350-DN600 material PP-R
- Connecting dimension: ISO 7005 PN 10, EN 1092 PN 10, DIN 2501 PN 10, ANSI/ASME B 16.5 Class 150, BS 1560: 1989, BS 4504, JIS B 2220
- Up to DN 300: Overall length according to EN558 (DN 50-200: line 25, DN250, 300 line 16), ISO 5752

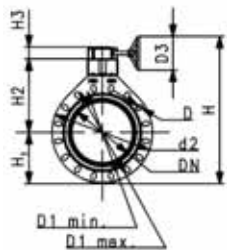
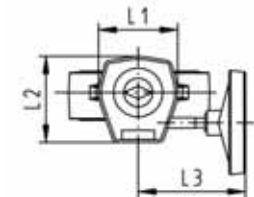
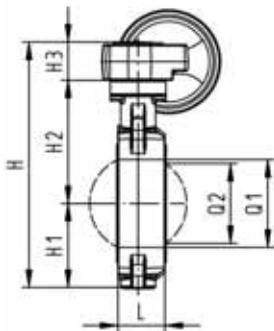
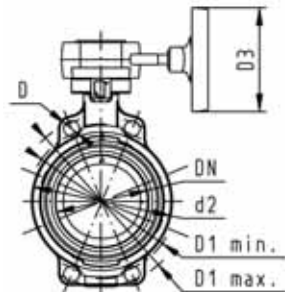

d [mm]	DN [mm]	Inch	PN	kv-value ($\Delta p=1$ bar) [l/min]	EPDM Code	FPM Code	PTFE Code	kg
63	50	2	10	1470	167 567 042	167 567 062	167 567 242	3.003
75	65	2 ½	10	2200	167 567 043	167 567 063	167 567 243	2.781
90	80	3	10	3000	167 567 044	167 567 064	167 567 244	3.301
110	100	4	10	6500	167 567 045	167 567 065	167 567 245	3.736
140	125	5	10	11500	167 567 046	167 567 066	167 567 246	2.770
160	150	6	10	16600	167 567 047	167 567 067	167 567 247	4.969
225	200	8	10	39600	167 567 048	167 567 068	167 567 248	8.538
280	250	10	8	51000	167 567 049	167 567 069	167 567 249	12.884
315	300	12	8	73000	167 567 050	167 567 070	167 567 250	16.442
355	350	14	6	90000	167 567 051	167 567 071		40.000
400	400	16	6	115000	167 567 052	167 567 072		50.000
450	450	18	5	155000	167 567 053	167 567 073		70.000
500	500	20	4	204000	167 567 054	167 567 074		90.000
630	600	24	4	265000	167 567 055	167 567 075		125.000

d [mm]	D [mm]	D1 min. [mm]	D1 max. [mm]	d2 [mm]	D3 [mm]	H1 [mm]	H2 [mm]	H3 [mm]	L [mm]	L1 [mm]	L2 [mm]	L3 [mm]	Q1 [mm]	Q2 [mm]
63	19	120	125	104	150	77	134	50	45	110	120	155	40	
75	19	140	145	115	150	83	140	50	46	110	120	155	54	35
90	19	150	160	131	150	89	146	50	49	110	120	155	67	50
110	19	175	191	160	150	104	167	50	56	110	120	155	88	74
140	23	210	216	187	150	117	181	50	64	110	120	155	113	97
160	24	241	241	215	150	130	189	50	72	110	120	155	139	123
225	23	290	295	267	150	158	210	50	73	110	120	155	178	169
280	25	353	362	329	200	205	264	55	113	130	140	200	210	207
315	25	400	432	379	200	228	285	55	113	130	140	200	256	253
355	29	445	477	535	200	268	410	69	129	180	168	218	325	305
400	29	510	540	595	200	300	435	69	169	180	195	218	353	350
450	32	565	578	635	250	320	520	81	179	220	195	240	393	390
500	32	620	635	700	350	350	550	94	190	220	226	260	444	440
630	35	725	750	813	350	420	610	94	209	220	260	260	530	527



Butterfly valve type 567 PP-H Bare shaft

Model:

- Material: PP-H, DN350-DN600 material PP-R
- Connecting dimension: ISO 7005 PN 10, EN 1092 PN 10, DIN 2501 PN 10, ANSI/ASME B 16.5 Class 150, BS 1560: 1989, BS 4504, JIS B 2220
- Up to DN 300: Overall length according to EN558 (DN 50-200: line 25, DN250, 300 line 16), ISO 5752
- Interface F07 for the dimensions DN50-200 according to DIN/ISO 5211
- Interface F10 for the dimensions DN250-300 according to DIN/ISO 5211
- Interface F12 for the Dimensions DN350-400 according to DIN/ISO 5211
- Interface F14 for the Dimensions DN450-600 according to DIN/ISO 5211

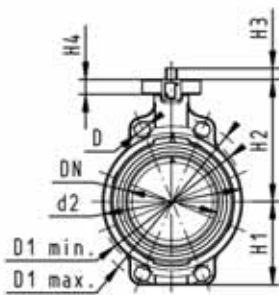

d [mm]	DN [mm]	Inch	PN	kv-value ($\Delta p=1$ bar) [l/min]	EPDM Code	FPM Code	PTFE Code	kg
63	50	2	10	1470	167 567 802	167 567 822	167 567 840	0.699
75	65	2 ½	10	2200	167 567 803	167 567 823	167 567 841	0.793
90	80	3	10	3000	167 567 804	167 567 824	167 567 842	0.913
110	100	4	10	6500	167 567 805	167 567 825	167 567 843	1.409
140	125	5	10	11500	167 567 806	167 567 826	167 567 844	1.831
160	150	6	10	16600	167 567 807	167 567 827	167 567 845	2.641
225	200	8	10	39600	167 567 808	167 567 828	167 567 846	4.110
280	250	10	8	51000	167 567 809	167 567 829	167 567 847	9.412
315	300	12	8	73000	167 567 810	167 567 830	167 567 848	13.054
355	350	14	6	90000	167 567 811	167 567 831		35.000
400	400	16	6	115000	167 567 812	167 567 832		45.000
450	450	18	5	155000	167 567 813	167 567 833		60.000
500	500	20	4	204000	167 567 814	167 567 834		75.000
630	600	24	4	265000	167 567 815	167 567 835		110.000

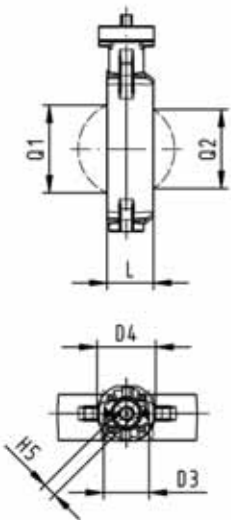

d [mm]	D [mm]	D1 min. [mm]	D1 max. [mm]	d2 [mm]	D3 [mm]	D4 [mm]	H1 [mm]	H2 [mm]	H3 [mm]	H4 [mm]	H5 [mm]	L [mm]	Q1 [mm]	Q2 [mm]
63	19	120	125	104	70	90	77	134	27	23	11	45	40	
75	19	140	145	115	70	90	83	140	27	23	11	46	54	35
90	19	150	160	131	70	90	89	146	27	23	11	49	67	50
110	19	175	191	161	70	90	104	167	16	23	14	56	88	74
140	23	210	216	187	70	90	117	181	16	23	14	64	113	97
160	24	241	241	215	70	90	130	189	19	23	17	72	139	123
225	23	290	295	267	70	90	158	210	19	23	17	73	178	169
280	25	353	362	329	102	125	205	264	40	23	22	113	210	207
315	25	400	432	379	102	125	228	285	40	23	22	113	256	253
355	29	445	477	535	125	180	268	410	31	100	27	129	325	305
400	29	510	540	595	125	180	300	435	31	100	27	169	353	350
450	32	565	578	635	140	220	320	520	35	120	36	179	393	390
500	32	620	635	700	140	220	350	550	35	120	36	190	444	440
630	35	725	750	813	140	220	420	610	35	120	36	209	530	527

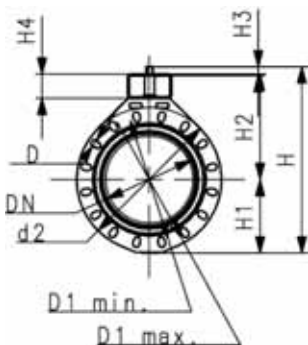



Integrated position indicator Automatic AU

Size	DN-DN [mm]	Code	kg
1	50 - 80	161 486 858	0.072
2	100 - 125	161 486 304	0.055
3	150 - 200	161 486 009	0.063



Integrated position indicator Automatic AG NI

Size	DN-DN [mm]	Code	kg
1	50 - 80	161 486 859	0.063
2	100 - 125	161 486 305	0.068
3	150 - 200	161 486 010	0.063



Integrated position indicator Electric Namur

Size	DN-DN [mm]	Code	kg
1	50 - 80	161 486 855	0.050
2	100 - 125	161 486 301	0.050
3	150 - 200	161 486 006	0.050



Integrated position indicator Electric PNP

Size	DN-DN [mm]	Code	kg
1	50 - 80	161 486 856	0.056
2	100 - 125	161 486 302	0.056
3	150 - 200	161 486 007	0.056



Integrated position indicator Electric NPN

Size	DN-DN [mm]	Code	kg
1	50 - 80	161 486 857	0.056
2	100 - 125	161 486 303	0.056
3	150 - 200	161 486 008	0.056



PROGEF Standard Lugstyle butterfly valve type 568 Hand lever with ratchet settings

Model:

- Material: PP-H
- Outer body in GGG-40.3 epoxy-coated
- Connecting dimension: ISO 7005 PN10, EN 1092 PN10, DIN 2501 PN10
- Overall length according to EN 558, ISO 5752

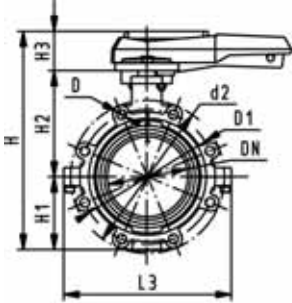

d [mm]	DN [mm]	Inch	PN	kv-value ($\Delta p=1$ bar) [l/min]	EPDM Code	FPM Code	PTFE Code	kg
63	50	2	10	1470	167 568 002	167 568 022	167 568 202	3.374
75	65	2 ½	10	2200	167 568 003	167 568 023	167 568 203	3.397
90	80	3	10	3000	167 568 004	167 568 024	167 568 204	4.817
110	100	4	10	6500	167 568 005	167 568 025	167 568 205	5.835
140	125	5	10	11500	167 568 006	167 568 026	167 568 206	7.665
160	150	6	10	16600	167 568 007	167 568 027	167 568 207	10.588
225	200	8	10	39600	167 568 008	167 568 028	167 568 208	18.188

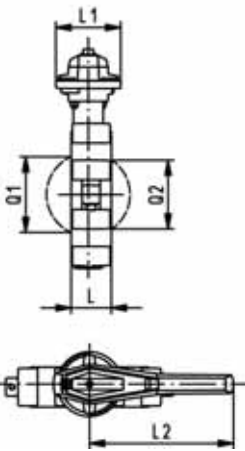

d [mm]	d2 [mm]	D	D1 [mm]	H [mm]	H1 [mm]	H2 [mm]	H3 [mm]	L [mm]	L1 [mm]	L2 [mm]	L3 [mm]	Q1 [mm]	Q2 [mm]
63	150	M16	125	265	77	134	54	45	106	205	150	40	
75	170	M16	145	277	83	140	54	46	106	205	160	54	35
90	184	M16	160	289	89	146	54	49	106	205	205	67	50
110	216	M16	180	326	104	167	55	56	106	255	244	88	74
140	246	M16	210	353	117	181	55	64	106	255	272	113	97
160	273	M20	240	374	130	189	55	72	106	255	297	139	123
225	334	M20	295	435	158	210	67	73	140	408	360	178	169



PROGEF Standard Lugstyle butterfly valve type 568 Reduction gear with handwheel

Model:

- Material: PP-H
- Outer body in GGG-40.3 epoxy-coated
- Connecting dimension: ISO 7005 PN10, EN 1092 PN10, DIN 2501 PN10
- Overall length according to EN 558, ISO 5752

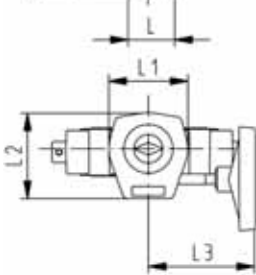
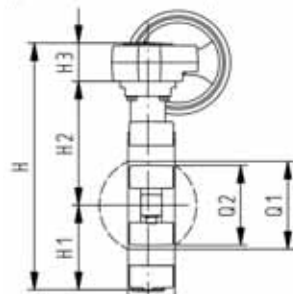
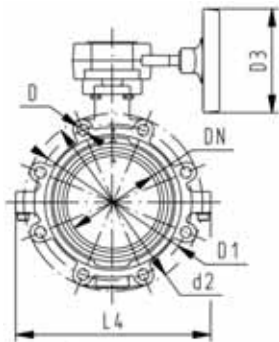

d [mm]	DN [mm]	Inch	PN	kv-value ($\Delta p=1$ bar) [l/min]	EPDM Code	FPM Code	PTFE Code	kg
63	50	2	10	1470	167 568 042	167 568 062	167 568 242	5.093
75	65	2 ½	10	2200	167 568 043	167 568 063	167 568 243	5.435
90	80	3	10	3000	167 568 044	167 568 064	167 568 244	6.440
110	100	4	10	6500	167 568 045	167 568 065	167 568 245	8.239
140	125	5	10	11500	167 568 046	167 568 066	167 568 246	10.544
160	150	6	10	16600	167 568 047	167 568 067	167 568 247	12.255
225	200	8	10	39600	167 568 048	167 568 068	167 568 248	16.107

d [mm]	d2 [mm]	D	D1 [mm]	D3 [mm]	H [mm]	H1 [mm]	H2 [mm]	H3 [mm]	L [mm]	L1 [mm]	L2 [mm]	L3 [mm]	L4 [mm]	Q1 [mm]
63	150	M16	125	150	279	77	134	50	45	110	120	155	150	40
75	170	M16	145	150	291	83	140	50	46	110	120	155	160	54
90	184	M16	160	150	303	89	146	50	49	110	120	155	205	67
110	216	M16	180	150	339	104	167	50	56	110	120	155	244	88
140	246	M16	210	150	366	117	181	50	64	110	120	155	272	113
160	273	M20	240	150	387	130	189	50	72	110	120	155	297	139
225	334	M20	295	150	436	158	210	50	73	110	120	155	360	178

d [mm]	Q2 [mm]
63	
75	35
90	50
110	74
140	97
160	123
225	169



PROGEF Standard Lugstyle butterfly valve type 568 Bare shaft

Model:

- Material: PP-H
- Outer body in GGG-40.3 epoxy-coated
- Connecting dimension: ISO 7005 PN10, EN 1092 PN10, DIN 2501 PN10
- Overall length according to EN 558, ISO 5752
- Interface F07 according to DIN/ISO 5211

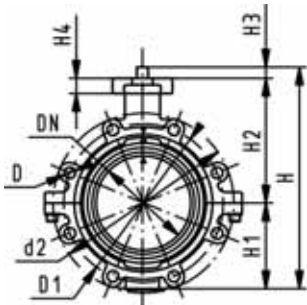

d [mm]	DN [mm]	Inch	PN	kv-value ($\Delta p=1$ bar) [l/min]	EPDM Code	FPM Code	PTFE Code	kg
63	50	2	10	1470	167 568 802	167 568 822	167 568 840	2.833
75	65	2 ½	10	2200	167 568 803	167 568 823	167 568 841	3.175
90	80	3	10	3000	167 568 804	167 568 824	167 568 842	4.180
110	100	4	10	6500	167 568 805	167 568 825	167 568 843	5.565
140	125	5	10	11500	167 568 806	167 568 826	167 568 844	7.395
160	150	6	10	16600	167 568 807	167 568 827	167 568 845	9.179
225	200	8	10	39600	167 568 808	167 568 828	167 568 846	13.847

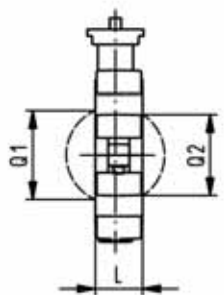

d [mm]	d2 [mm]	D	D1 [mm]	D3 [mm]	D4 [mm]	H [mm]	H1 [mm]	H2 [mm]	H3 [mm]	H4 [mm]	L [mm]	Q1 [mm]	Q2 [mm]
63	150	M16	125	70	90	222	77	134	27	23	45	40	
75	170	M16	145	70	90	235	83	140	27	23	46	54	35
90	184	M16	160	70	90	247	89	146	27	23	49	67	50
110	216	M16	180	70	90	287	104	167	16	23	56	88	74
140	246	M16	210	70	90	313	117	181	16	23	64	113	97
160	273	M20	240	70	90	335	130	189	19	23	72	139	123
225	334	M20	295	70	90	387	158	210	19	23	73	178	169

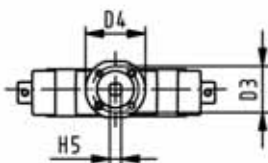



PROGEF Standard Lugstyle butterfly valve type 568 Hand lever with ratchet settings

Model:

- Material: PP-H
- Outer body in GGG-40.3 epoxy-coated
- Connecting dimension ANSI/ASME B 16.5 Class 150
- Overall length according to EN 558, ISO 5752

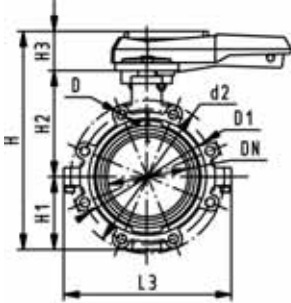

Inch	DN [mm]	PN	kv-value ($\Delta p=1$ bar) [l/min]	EPDM Code	FPM Code	PTFE Code	kg
2	50	10	1470	167 568 102	167 568 122	167 568 302	3.055
2 ½	65	10	2200	167 568 103	167 568 123	167 568 303	3.397
3	80	10	3000	167 568 104	167 568 124	167 568 304	3.773
4	100	10	6500	167 568 105	167 568 125	167 568 305	5.835
5	125	10	11500	167 568 106	167 568 126	167 568 306	7.665
6	150	10	16600	167 568 107	167 568 127	167 568 307	9.449
8	200	10	39600	167 568 108	167 568 128	167 568 308	14.654

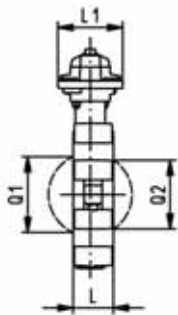

Inch	d2 [mm]	D	D1 [mm]	H [mm]	H1 [mm]	H2 [mm]	H3 [mm]	L [mm]	L1 [mm]	L2 [mm]	L3 [mm]	Q1 [mm]	Q2 [mm]
2	150	UNC 5/8	121	265	77	134	54	45	106	205	150	40	
2 ½	170	UNC 5/8	138	277	83	140	54	46	106	205	160	54	35
3	177	UNC 5/8	152	289	89	146	54	49	106	205	175	67	50
4	216	UNC 5/8	191	326	104	167	55	56	106	255	244	88	74
5	246	UNC 3/4	216	353	117	181	55	64	106	255	272	113	97
6	273	UNC 3/4	241	374	130	189	55	72	106	255	297	139	123
8	334	UNC 3/4	298	435	158	210	67	73	140	408	360	178	169

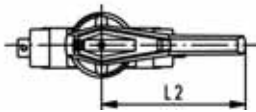



PROGEF Standard Lugstyle butterfly valve type 568 Reduction gear with handwheel

Model:

- Material: PP-H
- Outer body in GGG-40.3 epoxy-coated
- Connecting dimension ANSI/ASME B 16.5 Class 150
- Overall length according to EN 558, ISO 5752

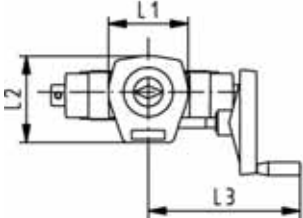
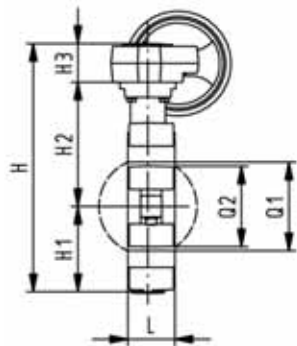
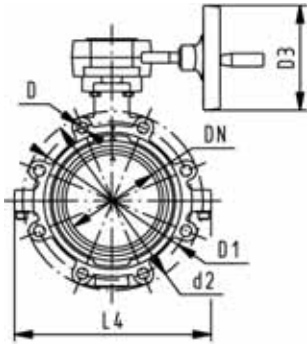

Inch	DN [mm]	PN	kv-value ($\Delta p=1$ bar) [l/min]	EPDM Code	FPM Code	PTFE Code	kg
2	50	10	1470	167 568 142	167 568 162	167 568 342	5.093
2 ½	65	10	2200	167 568 143	167 568 163	167 568 343	5.435
3	80	10	3000	167 568 144	167 568 164	167 568 344	5.955
4	100	10	6500	167 568 145	167 568 165	167 568 345	7.825
5	125	10	11500	167 568 146	167 568 166	167 568 346	9.655
6	150	10	16600	167 568 147	167 568 167	167 568 347	11.439
8	200	10	39600	167 568 148	167 568 168	167 568 348	16.107

Inch	d2 [mm]	D	D1 [mm]	D3 [mm]	H [mm]	H1 [mm]	H2 [mm]	H3 [mm]	L [mm]	L1 [mm]	L2 [mm]	L3 [mm]	L4 [mm]	Q1 [mm]
2	150	UNC 5/8	121	150	279	77	134	50	45	110	120	155	150	40
2 ½	170	UNC 5/8	138	150	291	83	140	50	46	110	120	155	160	54
3	177	UNC 5/8	152	150	303	89	146	50	49	110	120	155	175	67
4	216	UNC 5/8	191	150	339	104	167	50	56	110	120	155	244	88
5	246	UNC 3/4	216	150	366	117	181	50	64	110	120	155	272	113
6	273	UNC 3/4	241	150	387	130	189	50	72	110	120	155	297	139
8	334	UNC 3/4	298	150	436	158	210	50	73	110	120	155	360	178

Inch	Q2 [mm]
2	
2 ½	35
3	50
4	74
5	97
6	123
8	169



PROGEF Standard Lugstyle butterfly valve type 568 Bare shaft

Model:

- Material: PP-H
- Outer body in GGG-40.3 epoxy-coated
- Connecting dimension ANSI/ASME B 16.5 Class 150
- Overall length according to EN 558, ISO 5752
- Interface F07 according to DIN/ISO 5211

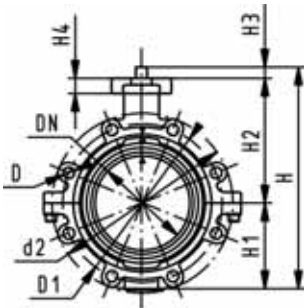

Inch	DN [mm]	PN	kv-value ($\Delta p=1$ bar) [l/min]	EPDM Code	FPM Code	PTFE Code	kg
2	50	10	1470	167 568 902	167 568 922	167 568 942	2.833
2 ½	65	10	2200	167 568 903	167 568 923	167 568 943	3.175
3	80	10	3000	167 568 904	167 568 924	167 568 944	3.551
4	100	10	6500	167 568 905	167 568 925	167 568 945	5.565
5	125	10	11500	167 568 906	167 568 926	167 568 946	7.395
6	150	10	16600	167 568 907	167 568 927	167 568 947	9.179
8	200	10	39600	167 568 908	167 568 928	167 568 948	13.847

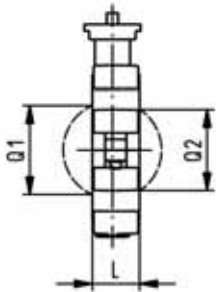

Inch	d2 [mm]	D	D1 [mm]	D3 [mm]	D4 [mm]	H [mm]	H1 [mm]	H2 [mm]	H3 [mm]	H4 [mm]	L [mm]	Q1 [mm]	Q2 [mm]
2	150	UNC 5/8	121	70	90	222	77	134	27	23	45	40	
2 ½	170	UNC 5/8	138	70	90	235	83	140	27	23	46	54	35
3	177	UNC 5/8	152	70	90	247	89	146	27	23	49	67	50
4	216	UNC 5/8	191	70	90	287	104	167	16	23	56	88	74
5	246	UNC 3/4	216	70	90	313	117	181	16	23	64	113	97
6	273	UNC 3/4	241	70	90	335	130	189	19	23	72	139	123
8	334	UNC 3/4	298	70	90	387	158	210	19	23	73	178	169

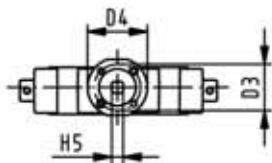

Cone check valves

PROGEF Standard Check valve type 561 With fusion sockets metric



Model:

- Material: PP-H
- Designed for easy installation and removal
- Vibration free even at high flow velocity
- Flow-optimized return cone, double guided
- For vertical installation
- Compact installation length, same as ball valve type 546
- Z-length, end connectors and union nuts **not** compatible with type 360

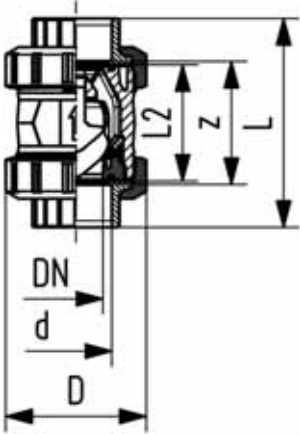

d [mm]	DN [mm]	PN	kv-value ($\Delta p=1$ bar) [l/min]	EPDM Code	FPM Code	kg	D [mm]	L [mm]	L2 [mm]	z [mm]
16	10	10	190	167 561 001	167 561 011	0.080	50	93	56	67
20	15	10	180	167 561 002	167 561 012	0.080	50	95	56	66
25	20	10	380	167 561 003	167 561 013	0.180	58	109	65	77
32	25	10	460	167 561 004	167 561 014	0.190	68	119	71	83
40	32	10	850	167 561 005	167 561 015	0.340	84	135	85	99
50	40	10	1080	167 561 006	167 561 016	0.480	97	147	89	105
63	50	10	1670	167 561 007	167 561 017	0.974	124	168	101	117
75	65	10	2950	167 561 008	167 561 018	2.310	166	233	136	167
90	80	10	3600	167 561 009	167 561 019	3.580	200	254	141	180
110	100	10	4150	167 561 010	167 561 020	5.930	238	301	164	215

PROGEF Standard Check valve type 561 With socket fusion spigots metric



Model:

- Material: PP-H
- Designed for easy installation and removal
- Vibration free even at high flow velocity
- Flow-optimized return cone, double guided
- For vertical installation
- Compact installation length, same as ball valve type 546
- Z-length, end connectors and union nuts **not** compatible with type 360

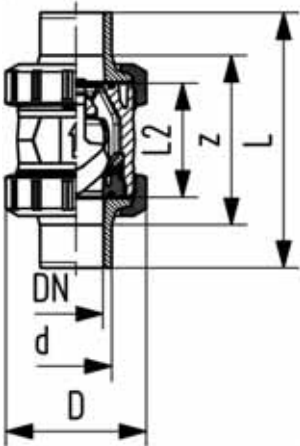

d [mm]	DN [mm]	PN	kv-value ($\Delta p=1$ bar) [l/min]	EPDM Code	FPM Code	kg	D [mm]	L [mm]	L2 [mm]
16	10	10	190	167 561 041	167 561 051	0.080	50	110	56
20	15	10	180	167 561 042	167 561 052	0.090	50	120	56
25	20	10	380	167 561 043	167 561 053	0.190	58	139	65
32	25	10	460	167 561 044	167 561 054	0.200	68	150	71
40	32	10	850	167 561 045	167 561 055	0.350	84	170	85
50	40	10	1080	167 561 046	167 561 056	0.510	97	190	89
63	50	10	1670	167 561 047	167 561 057	0.950	124	220	101
75	65	10	2950	167 561 048	167 561 058	2.370	166	280	136
90	80	10	3600	167 561 049	167 561 059	3.750	200	296	141
110	100	10	4150	167 561 050	167 561 060	5.980	238	336	164



PROGEF Standard Check valve type 561 With threaded sockets reinforced Rp

Model:

- Material: PP-H
- Designed for easy installation and removal
- Vibration free even at high flow velocity
- Flow-optimized return cone, double guided
- For vertical installation
- Compact installation length, same as ball valve type 546
- Z-length, end connectors and union nuts **not** compatible with type 360

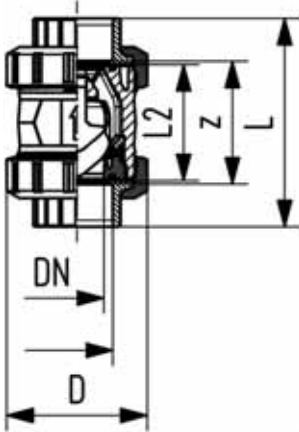

Rp [inch]	DN [mm]	PN	kv-value ($\Delta p=1$ bar) [l/min]	EPDM Code	FPM Code	kg	D [mm]	L [mm]	L2 [mm]	z [mm]
3/8	10	10	190	167 561 021	167 561 031	0.080	50	96	56	69
1/2	15	10	180	167 561 022	167 561 032	0.090	50	99	56	67
3/4	20	10	380	167 561 023	167 561 033	0.180	58	111	65	78
1	25	10	460	167 561 024	167 561 034	0.210	68	127	71	85
1 1/4	32	10	850	167 561 025	167 561 035	0.360	84	146	85	100
1 1/2	40	10	1080	167 561 026	167 561 036	0.510	97	157	89	106
2	50	10	1670	167 561 027	167 561 037	0.920	124	183	101	121



PROGEF Standard Check valve type 561 With fixed flanges metric

Model:

- Material: PP-H
- Designed for easy installation and removal
- Vibration free even at high flow velocity
- Flow-optimized return cone, double guided
- For vertical installation
- Compact installation length, same as ball valve type 546
- Z-length, end connectors and union nuts **not** compatible with type 360
- Installation length according to EN 558-1
- Connecting dimension: ISO 7005 PN10, EN 1092 PN10, DIN 2501 PN10

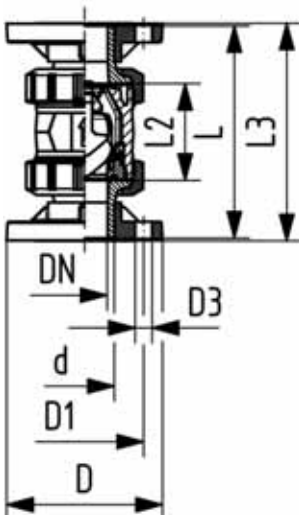

d [mm]	DN [mm]	PN	kv-value ($\Delta p=1$ bar) [l/min]	EPDM Code	FPM Code	kg
20	15	10	180	167 561 182	167 561 192	0.220
25	20	10	380	167 561 183	167 561 193	0.350
32	25	10	460	167 561 184	167 561 194	0.440
40	32	10	850	167 561 185	167 561 195	0.730
50	40	10	1080	167 561 186	167 561 196	0.970
63	50	10	1670	167 561 187	167 561 197	1.600

d [mm]	D [mm]	D1 [mm]	D3 [mm]	L [mm]	L2 [mm]	L3 [mm]
20	95	65	14	120	56	130
25	105	75	14	140	65	150
32	115	85	14	150	71	160
40	140	100	18	170	85	180
50	150	110	18	190	89	200
63	165	125	18	220	101	230



PROGEF Standard Check valve type 561 With backing flanges PP-st metric

Model:

- Material: PP-H
- Designed for easy installation and removal
- Vibration free even at high flow velocity
- Flow-optimized return cone, double guided
- For vertical installation
- Compact installation length, same as ball valve type 546
- Z-length, end connectors and union nuts **not** compatible with type 360
- Overall length according to EN 558
- Connecting dimension: ISO 7005, EN 1092, BS 4504, DIN 2501

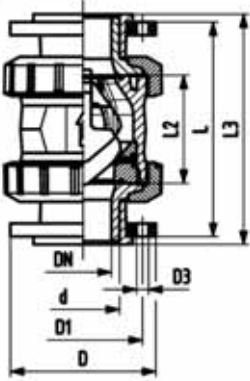

d [mm]	DN [mm]	PN	kv-value ($\Delta p=1$ bar) [l/min]	EPDM Code	FPM Code	kg
75	65	10	2950	167 561 428	167 561 438	4.720
90	80	10	3600	167 561 429	167 561 439	6.860
110	100	10	4150	167 561 430	167 561 440	9.300

d [mm]	D [mm]	D1 [mm]	D3 [mm]	H [mm]	H1 [mm]	L [mm]	L1 [mm]	L2 [mm]	L3 [mm]	L4 [mm]	L5 [mm]	L6 [mm]	M
75	166	145	18	149	85	280	270	136	290	70	64	206	M8
90	200	160	18	161	105	296	270	141	310	70	64	206	M8
110	238	180	18	178	123	336	320	164	350	120	64	256	M12



PROGEF Standard Check valve type 561 With butt fusion spigots SDR17,6 metric

Model:

- Material: PP-H
- Designed for easy installation and removal
- Vibration free even at high flow velocity
- Flow-optimized return cone, double guided
- For vertical installation
- Compact installation length, same as ball valve type 546
- Z-length, end connectors and union nuts **not** compatible with type 360

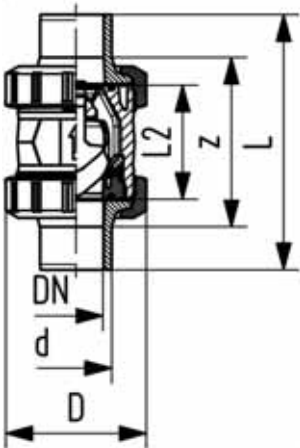

d [mm]	DN [mm]	PN	kv-value ($\Delta p=1$ bar) [l/min]	EPDM Code	FPM Code	kg	D [mm]	L [mm]	L2 [mm]	e [mm]
50	40	10	1080	167 561 066	167 561 076	0.510	97	191	89	2.9
63	50	10	1670	167 561 067	167 561 077	0.940	124	220	101	3.6
75	65	10	2950	167 561 068	167 561 078	2.360	166	266	136	4.7
90	80	10	3600	167 561 069	167 561 079	3.670	200	264	141	5.5
110	100	10	4150	167 561 070	167 561 080	5.820	238	301	164	6.8

PROGEF Standard Check valve type 561 With butt fusion spigots IR-Plus SDR11 metric



Model:

- Material: PP-H
- Designed for easy installation and removal
- Vibration free even at high flow velocity
- Flow-optimized return cone, double guided
- For vertical installation
- Compact installation length, same as ball valve type 546
- Z-length, end connectors and union nuts **not** compatible with type 360

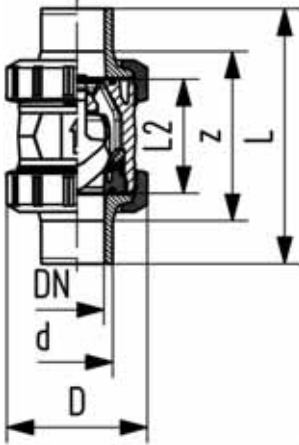

d [mm]	DN [mm]	PN	kv-value ($\Delta p=1$ bar) [l/min]	EPDM Code	FPM Code	kg	D [mm]	L [mm]	L2 [mm]	e [mm]
20	15	10	180	167 561 082	167 561 092	0.080	50	130	56	1.9
25	20	10	380	167 561 083	167 561 093	0.180	58	143	65	2.3
32	25	10	460	167 561 084	167 561 094	0.190	68	150	71	2.9
40	32	10	850	167 561 085	167 561 095	0.340	84	171	85	3.7
50	40	10	1080	167 561 086	167 561 096	0.490	97	191	89	4.6
63	50	10	1670	167 561 087	167 561 097	0.930	124	220	101	5.8
75	65	10	2950	167 561 088	167 561 098	2.360	166	266	136	6.8
90	80	10	3600	167 561 089	167 561 099	3.680	200	264	141	8.2
110	100	10	4150	167 561 090	167 561 100	5.830	238	301	164	10.0



PROGEF Standard Check valve type 562 With fusion sockets metric

Model:

- Material: PP-H
- Spring loaded, spring made of stainless steel (1.4310)
- Spring available in other materials, see spare parts
- Designed for easy installation and removal
- Vibration free even at high flow velocity
- Flow-optimized return cone, double guided
- For horizontal or vertical installation
- Compact installation length, same as ball valve type 546
- Z-length, end connectors and union nuts **not** compatible with type 360

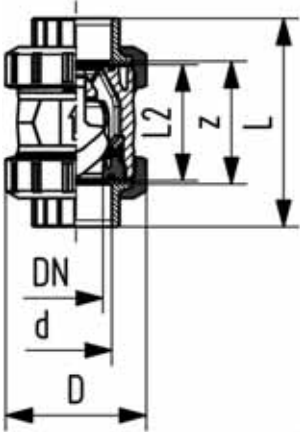

d [mm]	DN [mm]	PN	kv-value ($\Delta p=1$ bar) [l/min]	EPDM Code	FPM Code	kg	D [mm]	L [mm]	L2 [mm]	z [mm]
16	10	10	190	167 562 001	167 562 011	0.080	50	93	56	67
20	15	10	180	167 562 002	167 562 012	0.080	50	95	56	66
25	20	10	380	167 562 003	167 562 013	0.180	58	109	65	77
32	25	10	460	167 562 004	167 562 014	0.190	68	119	71	83
40	32	10	850	167 562 005	167 562 015	0.340	84	135	85	99
50	40	10	1080	167 562 006	167 562 016	0.480	97	147	89	105
63	50	10	1670	167 562 007	167 562 017	0.880	124	168	101	117
75	65	10	2950	167 562 008	167 562 018	2.310	166	233	136	167
90	80	10	3600	167 562 009	167 562 019	3.580	200	254	141	180
110	100	10	4150	167 562 010	167 562 020	5.930	238	301	164	215



PROGEF Standard Check valve type 562 With socket fusion spigots metric

Model:

- Material: PP-H
- Spring loaded, spring made of stainless steel (1.4310)
- Spring available in other materials, see spare parts
- Designed for easy installation and removal
- Vibration free even at high flow velocity
- Flow-optimized return cone, double guided
- For horizontal or vertical installation
- Compact installation length, same as ball valve type 546
- Z-length, end connectors and union nuts **not** compatible with type 360

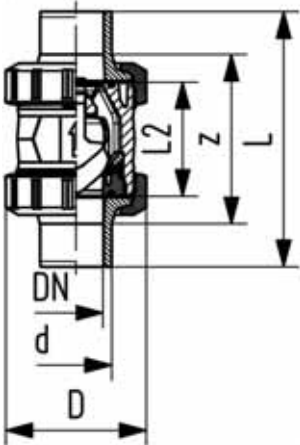

d [mm]	DN [mm]	PN	kv-value ($\Delta p=1$ bar) [l/min]	EPDM Code	FPM Code	kg	D [mm]	L [mm]	L2 [mm]
16	10	10	190	167 562 041	167 562 051	0.080	50	110	56
20	15	10	180	167 562 042	167 562 052	0.090	50	120	56
25	20	10	380	167 562 043	167 562 053	0.190	58	139	65
32	25	10	460	167 562 044	167 562 054	0.200	68	150	71
40	32	10	850	167 562 045	167 562 055	0.350	84	170	85
50	40	10	1080	167 562 046	167 562 056	0.510	97	190	89
63	50	10	1670	167 562 047	167 562 057	0.950	124	220	101
75	65	10	2950	167 562 048	167 562 058	2.370	166	280	136
90	80	10	3600	167 562 049	167 562 059	3.750	200	296	141
110	100	10	4150	167 562 050	167 562 060	5.980	238	336	164



PROGEF Standard Check valve type 562 With threaded sockets reinforced Rp

Model:

- Material: PP-H
- Spring loaded, spring made of stainless steel (1.4310)
- Spring available in other materials, see spare parts
- Designed for easy installation and removal
- Vibration free even at high flow velocity
- Flow-optimized return cone, double guided
- For horizontal or vertical installation
- Compact installation length, same as ball valve type 546
- Z-length, end connectors and union nuts **not** compatible with type 360

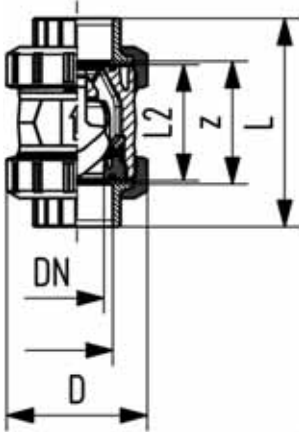

Rp [inch]	DN [mm]	PN	kv-value ($\Delta p=1$ bar) [l/min]	EPDM Code	FPM Code	kg	D [mm]	L [mm]	L2 [mm]	z [mm]
3/8	10	10	190	167 562 021	167 562 031	0.080	50	96	56	69
1/2	15	10	180	167 562 022	167 562 032	0.090	50	99	56	67
3/4	20	10	380	167 562 023	167 562 033	0.180	58	111	65	78
1	25	10	460	167 562 024	167 562 034	0.210	68	127	71	85
1 1/4	32	10	850	167 562 025	167 562 035	0.360	84	146	85	100
1 1/2	40	10	1080	167 562 026	167 562 036	0.510	97	157	89	106
2	50	10	1670	167 562 027	167 562 037	0.920	124	183	101	121



PROGEF Standard Check valve type 562 With fixed flanges metric

Model:

- Material: PP-H
- Spring loaded, spring made of stainless steel (1.4310)
- Spring available in other materials, see spare parts
- Designed for easy installation and removal
- Vibration free even at high flow velocity
- Flow-optimized return cone, double guided
- For horizontal or vertical installation
- Compact installation length, same as ball valve type 546
- Z-length, end connectors and union nuts **not** compatible with type 360
- Installation length according to EN 558-1
- Connecting dimension: ISO 7005 PN10, EN 1092 PN10, DIN 2501 PN10

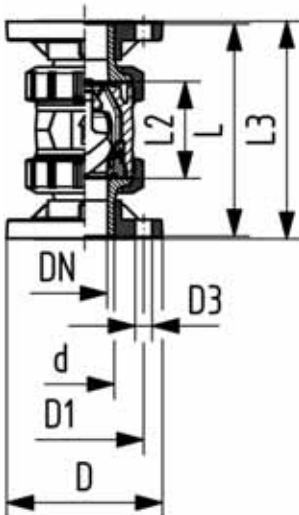

d [mm]	DN [mm]	PN	kv-value ($\Delta p=1$ bar) [l/min]	EPDM Code	FPM Code	kg
20	15	10	180	167 562 182	167 562 192	0.220
25	20	10	380	167 562 183	167 562 193	0.350
32	25	10	460	167 562 184	167 562 194	0.440
40	32	10	850	167 562 185	167 562 195	0.730
50	40	10	1080	167 562 186	167 562 196	0.970
63	50	10	1670	167 562 187	167 562 197	1.600

d [mm]	D [mm]	D1 [mm]	D3 [mm]	L [mm]	L2 [mm]	L3 [mm]
20	95	65	14	120	56	130
25	105	75	14	140	65	150
32	115	85	14	150	71	160
40	140	100	18	170	85	180
50	150	110	18	190	89	200
63	165	125	18	220	101	230



PROGEF Standard Check valve type 562 With backing flanges PP-st metric

Model:

- Material: PP-H
- Spring loaded, spring made of stainless steel (1.4310)
- Spring available in other materials, see spare parts
- Designed for easy installation and removal
- Vibration free even at high flow velocity
- Flow-optimized return cone, double guided
- For horizontal or vertical installation
- Compact installation length, same as ball valve type 546
- Z-length, end connectors and union nuts **not** compatible with type 360
- Overall length according to EN 558
- Connecting dimension: ISO 7005, EN 1092, BS 4504, DIN 2501

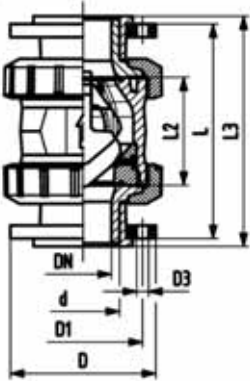

d [mm]	DN [mm]	PN	kv-value ($\Delta p=1$ bar) [l/min]	EPDM Code	FPM Code	kg
75	65	10	2950	167 562 428	167 562 438	4.720
90	80	10	3600	167 562 429	167 562 439	6.860
110	100	10	4150	167 562 430	167 562 440	9.300

d [mm]	D [mm]	D1 [mm]	D3 [mm]	H [mm]	H1 [mm]	L [mm]	L1 [mm]	L2 [mm]	L3 [mm]	L4 [mm]	L5 [mm]	L6 [mm]	M
75	166	145	18	149	85	280	270	136	290	70	64	206	M8
90	200	160	18	161	105	296	270	141	310	70	64	206	M8
110	238	180	18	178	123	336	320	164	350	120	64	256	M12



PROGEF Standard Check valve type 562 With butt fusion spigots SDR17,6 metric

Model:

- Material: PP-H
- Spring loaded, spring made of stainless steel (1.4310)
- Spring available in other materials, see spare parts
- Designed for easy installation and removal
- Vibration free even at high flow velocity
- Flow-optimized return cone, double guided
- For horizontal or vertical installation
- Compact installation length, same as ball valve type 546
- Z-length, end connectors and union nuts **not** compatible with type 360

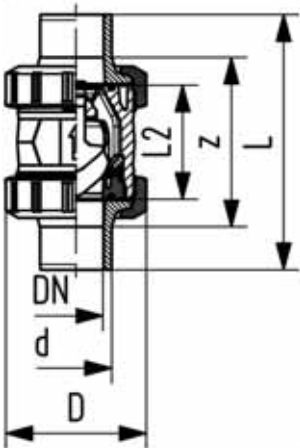

d [mm]	DN [mm]	PN	kv-value ($\Delta p=1$ bar) [l/min]	EPDM Code	FPM Code	kg	D [mm]	L [mm]	L2 [mm]	e [mm]
50	40	10	1080	167 562 066	167 562 076	0.510	97	191	89	2.9
63	50	10	1670	167 562 067	167 562 077	0.940	124	220	101	3.6
75	65	10	2950	167 562 068	167 562 078	2.360	166	266	136	4.7
90	80	10	3600	167 562 069	167 562 079	3.670	200	264	141	5.5
110	100	10	4150	167 562 070	167 562 080	5.820	238	301	164	6.8

PROGEF Standard Check valve type 562 With butt fusion spigots IR-Plus SDR11 metric



Model:

- Material: PP-H
- Spring loaded, spring made of stainless steel (1.4310)
- Spring available in other materials, see spare parts
- Designed for easy installation and removal
- Vibration free even at high flow velocity
- Flow-optimized return cone, double guided
- For horizontal or vertical installation
- Compact installation length, same as ball valve type 546
- Z-length, end connectors and union nuts **not** compatible with type 360

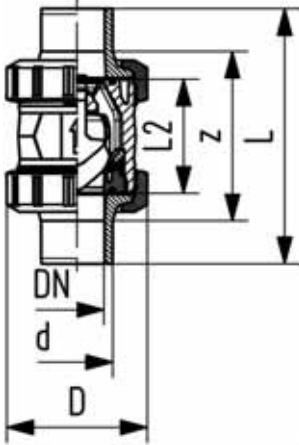

d [mm]	DN [mm]	PN	kv-value ($\Delta p=1$ bar) [l/min]	EPDM Code	FPM Code	kg	D [mm]	L [mm]	L2 [mm]	e [mm]
20	15	10	180	167 562 082	167 562 092	0.080	50	130	56	1.9
25	20	10	380	167 562 083	167 562 093	0.180	58	143	65	2.3
32	25	10	460	167 562 084	167 562 094	0.190	68	150	71	2.9
40	32	10	850	167 562 085	167 562 095	0.340	84	171	85	3.7
50	40	10	1080	167 562 086	167 562 096	0.490	97	191	89	4.6
63	50	10	1670	167 562 087	167 562 097	0.930	124	220	101	5.8
75	65	10	2950	167 562 088	167 562 098	2.360	166	266	136	6.8
90	80	10	3600	167 562 089	167 562 099	3.680	200	264	141	8.2
110	100	10	4150	167 562 090	167 562 100	5.830	238	301	164	10.0

Air release valve

PROGEF Standard Ventilating and bleed valve type 591 With fusion sockets metric



Model:

- Material: PP-H
- With protection cap up to DN50 made of PP-GF, DN65-100 made of POM
- Floater made of PP-H
- Designed for easy installation and removal
- Compact installation length

d [mm]	DN [mm]	PN	EPDM Code	FPM Code	kg	D [mm]	L [mm]	t [mm]
16	10	10	167 591 001	167 591 011	0.097	50	126	14
20	15	10	167 591 002	167 591 012	0.097	50	127	15
25	20	10	167 591 003	167 591 013	0.203	58	142	16
32	25	10	167 591 004	167 591 014	0.224	68	153	18
40	32	10	167 591 005	167 591 015	0.392	84	171	19
50	40	10	167 591 006	167 591 016	0.549	97	190	21
63	50	10	167 591 007	167 591 017	0.986	124	219	28
75	65	10	167 591 008	167 591 018	2.310	166	256	29
90	80	10	167 591 009	167 591 019	3.580	200	275	33
110	100	10	167 591 010	167 591 020	5.930	238	318	39

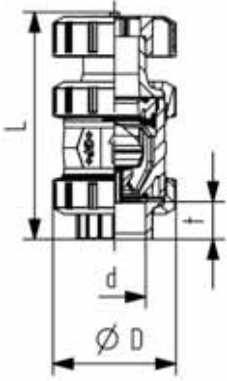

PROGEF Standard Ventilating and bleed valve type 591 With socket fusion spigots metric



Model:

- Material: PP-H
- With protection cap up to DN50 made of PP-GF, DN65-100 made of POM
- Floater made of PP-H
- Designed for easy installation and removal
- Compact installation length

d [mm]	DN [mm]	PN	EPDM Code	FPM Code	kg	D [mm]	L [mm]	t [mm]
16	10	10	167 591 041	167 591 051	0.097	50	135	13
20	15	10	167 591 042	167 591 052	0.107	50	140	14
25	20	10	167 591 043	167 591 053	0.213	58	157	16
32	25	10	167 591 044	167 591 054	0.234	68	168	18
40	32	10	167 591 045	167 591 055	0.402	84	189	20
50	40	10	167 591 046	167 591 056	0.579	97	211	23
63	50	10	167 591 047	167 591 057	1.056	124	245	27
75	65	10	167 591 048	167 591 058	2.370	166	280	48
90	80	10	167 591 049	167 591 059	3.750	200	296	49
110	100	10	167 591 050	167 591 060	5.980	238	336	54

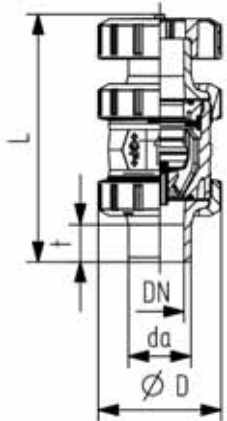

PROGEF Standard Ventilating valve type 595 With fusion sockets metric

Model:

- Material: PP-H
- With protection cap up to DN50 made of PP-GF, DN65-100 made of POM
- Spring loaded, spring made of NIMONIC 90, HALAR coated
- Spring available in other materials, see spare parts
- Designed for easy installation and removal
- Compact installation length

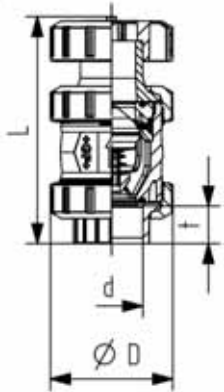

d [mm]	DN [mm]	PN	EPDM Code	FPM Code	kg	D [mm]	L [mm]	t [mm]
16	10	10	167 595 001	167 595 011	0.097	50	126	14
20	15	10	167 595 002	167 595 012	0.097	50	127	15
25	20	10	167 595 003	167 595 013	0.203	58	142	16
32	25	10	167 595 004	167 595 014	0.224	68	153	18
40	32	10	167 595 005	167 595 015	0.392	84	171	19
50	40	10	167 595 006	167 595 016	0.549	97	190	21
63	50	10	167 595 007	167 595 017	0.986	124	219	28
75	65	10	167 595 008	167 595 018	2.310	166	256	29
90	80	10	167 595 009	167 595 019	3.580	200	275	33
110	100	10	167 595 010	167 595 020	5.930	238	318	39

PROGEF Standard Ventilating valve type 595 With socket fusion spigots metric

Model:

- Material: PP-H
- With protection cap up to DN50 made of PP-GF, DN65-100 made of POM
- Spring loaded, spring made of NIMONIC 90, HALAR coated
- Spring available in other materials, see spare parts
- Designed for easy installation and removal
- Compact installation length

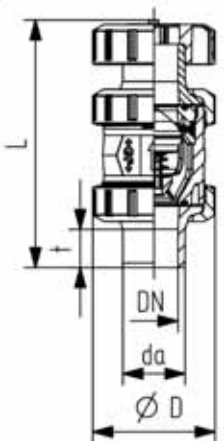

d [mm]	DN [mm]	PN	EPDM Code	FPM Code	kg	D [mm]	L [mm]	t [mm]
16	10	10	167 595 041	167 595 051	0.097	50	135	13
20	15	10	167 595 042	167 595 052	0.107	50	140	14
25	20	10	167 595 043	167 595 053	0.213	58	157	16
32	25	10	167 595 044	167 595 054	0.234	68	168	18
40	32	10	167 595 045	167 595 055	0.402	84	189	20
50	40	10	167 595 046	167 595 056	0.579	97	211	23
63	50	10	167 595 047	167 595 057	1.056	124	245	27
75	65	10	167 595 048	167 595 058	2.370	166	280	48
90	80	10	167 595 049	167 595 059	3.750	200	296	49
110	100	10	167 595 050	167 595 060	5.980	238	336	54

Wafer Check Valves 369

PROGEF Standard Wafer check valve type 369 Without spring

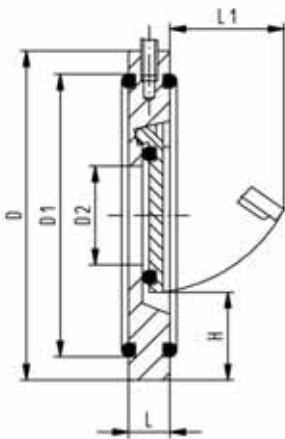

Model:

- Material: PP-H
- Supporting eyelets for simple fitting
- Suitable for vertical and horizontal mounting

Installation instruction:

- Installation between ISO/DIN (all dimensions) and ANSI flange adaptors (all except DN32 and DN125)
- It is necessary to use a special outlet flange adaptor PP or PE on the outgoing side of the wafer check valve
- Centering by body diameter
- Sealing with special flange gasket (except DN32, o-ring)
- A stabilizing zone of at least 5 times nominal diameter (DN) should be provided before and after the wafer check valve (10 times DN is recommended)
- No direct installation on pump flange or following bend allowed
- Wafer check valves without reset spring are not recommended for pulsating flows (production of noise)

d [mm]	DN [mm]	PN	EPDM Code	FPM Code	kg
40	32	6	167 369 002	167 369 022	0.084
50	40	10	167 369 003	167 369 023	0.110
63	50	10	167 369 004	167 369 024	0.159
75	65	10	167 369 005	167 369 025	0.232
90	80	10	167 369 006	167 369 026	0.264
110	100	10	167 369 007	167 369 027	0.405
140	125	10	167 369 009	167 369 029	0.594
160	150	6	167 369 010	167 369 030	0.805
225	200	6	167 369 011	167 369 031	1.400
280	250	6	167 369 012	167 369 032	2.400
315	300	6	167 369 013	167 369 033	3.520

d [mm]	D [mm]	D1 [mm]	D2 [mm]	H [mm]	L [mm]	L1 [mm]	Opening pressure vertical [mbar]	Opening pressure hor- izontal [mbar]	Minimum water col- umn for sealing [m]
40	85	59	18	25	15	22	10	1	3.0
50	95	72	22	28	16	27	10	1	3.0
63	109	86	32	29	18	40	10	1	3.0
75	129	105	40	31	20	55	10	1	3.0
90	144	119	54	32	20	67	10	1	3.0
110	164	146	70	31	23	67	10	1	3.0
140	195	173	92	35	23	94	10	1	3.0
160	220	197	105	42	26	100	10	1	3.0
225	275	255	154	38	35	152	18	1	3.0
280	330	312	192	41	40	180	18	1	3.0
315	380	363	227	41	45	215	18	1	3.0



PROGEF Standard Wafer check valve type 369 With V4A spring (stainless steel 316)

Model:

- Material: PP-H
- Supporting eyelets for simple fitting
- Suitable for vertical and horizontal mounting

Installation instruction:

- Installation between ISO/DIN (all dimensions) and ANSI flange adaptors (all except DN32 and DN125)
- It is necessary to use a special outlet flange adaptor PP or PE on the outgoing side of the wafer check valve
- Centering by body diameter
- Sealing with special flange gasket (except DN32, o-ring)
- A stabilizing zone of at least 5 times nominal diameter (DN) should be provided before and after the wafer check valve (10 times DN is recommended)
- No direct installation on pump flange or following bend allowed

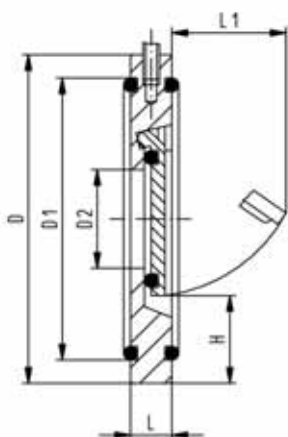

d [mm]	DN [mm]	PN	EPDM Code	FPM Code	kg
40	32	6	167 369 042	167 369 062	0.071
50	40	10	167 369 043	167 369 063	0.100
63	50	10	167 369 044	167 369 064	0.170
75	65	10	167 369 045	167 369 065	0.245
90	80	10	167 369 046	167 369 066	0.260
110	100	10	167 369 047	167 369 067	0.370
140	125	10	167 369 049	167 369 069	0.500
160	150	6	167 369 050	167 369 070	0.740
225	200	6	167 369 051	167 369 071	1.400
280	250	6	167 369 052	167 369 072	2.400
315	300	6	167 369 053	167 369 073	3.520

d [mm]	D [mm]	D1 [mm]	D2 [mm]	H [mm]	L [mm]	L1 [mm]	Opening pressure vertical [mbar]	Opening pressure hor- izontal [mbar]	Minimum water col- umn for sealing [m]
40	85	59	18	25	15	22	30	20	3.0
50	95	72	22	28	16	27	30	20	3.0
63	109	86	32	29	18	40	30	20	3.0
75	129	105	40	31	20	55	30	20	3.0
90	144	119	54	32	20	67	30	20	3.0
110	164	146	70	31	23	67	30	20	3.0
140	195	173	92	35	23	94	30	20	3.0
160	220	197	105	42	26	100	30	20	3.0
225	275	255	154	38	35	152	38	20	3.0
280	330	312	192	41	40	180	38	20	3.0
315	380	363	227	41	45	215	38	20	3.0

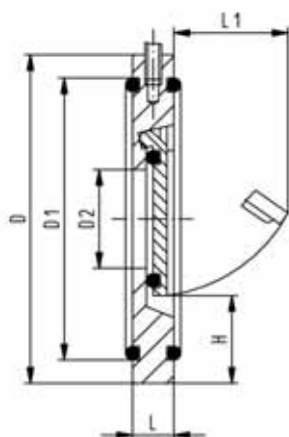

PROGEF Standard Wafer check valve type 369 With Hastelloy C spring

Model:

- Material: PP-H
- Supporting eyelets for simple fitting
- Suitable for vertical and horizontal mounting

Installation instruction:

- Installation between ISO/DIN (all dimensions) and ANSI flange adaptors (all except DN32 and DN125)
- It is necessary to use a special outlet flange adaptor PP or PE on the outgoing side of the wafer check valve
- Centering by body diameter
- Sealing with special flange gasket (except DN32, o-ring)
- A stabilizing zone of at least 5 times nominal diameter (DN) should be provided before and after the wafer check valve (10 times DN is recommended)
- No direct installation on pump flange or following bend allowed

d [mm]	DN [mm]	PN	EPDM Code	FPM Code	kg
40	32	6	167 369 082	167 369 102	0.090
50	40	10	167 369 083	167 369 103	0.097
63	50	10	167 369 084	167 369 104	0.170
75	65	10	167 369 085	167 369 105	0.220
90	80	10	167 369 086	167 369 106	0.264
110	100	10	167 369 087	167 369 107	0.370
140	125	10	167 369 089	167 369 109	0.500
160	150	6	167 369 090	167 369 110	0.760
225	200	6	167 369 091	167 369 111	1.400
280	250	6	167 369 092	167 369 112	2.400
315	300	6	167 369 093	167 369 113	3.520

d [mm]	D [mm]	D1 [mm]	D2 [mm]	H [mm]	L [mm]	L1 [mm]	Opening pressure vertical [mbar]	Opening pressure hor- izontal [mbar]	Minimum water col- umn for sealing [m]
40	85	59	18	25	15	22	30	20	3.0
50	95	72	22	28	16	27	30	20	3.0
63	109	86	32	29	18	40	30	20	3.0
75	129	105	40	31	20	55	30	20	3.0
90	144	119	54	32	20	67	30	20	3.0
110	164	146	70	31	23	67	30	20	3.0
140	195	173	92	35	23	94	30	20	3.0
160	220	197	105	42	26	100	30	20	3.0
225	275	255	154	38	35	152	38	20	3.0
280	330	312	192	41	40	180	38	20	3.0
315	380	363	227	41	45	215	38	20	3.0

Component Parts for Flange Assembly, Type 369 PP

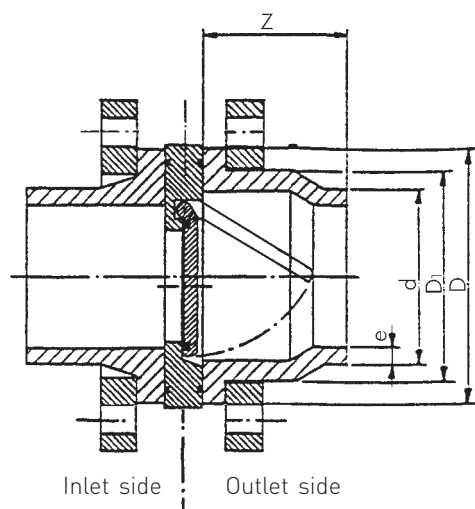

Warning: This outlet flange adaptor has to be installed on the outlet side!

Socket Fusion System PP/PE Inlet side

PP/PE
Flange adaptor
metric

d	DN	Inch	PP Code	PE Code				
40	32	1 ¹ / ₄	727 790 209	753 790 209				
50	40	1 ¹ / ₂	727 790 210	753 790 210				
63	50	2	727 790 211	753 790 211				
75	65	2 ¹ / ₂	727 790 212	753 790 212				
90	80	3	727 790 213	753 790 213				
110	100	4	727 790 214	753 790 214				

Backing flange metric
for socket fusion systems
Connecting dimension
DIN 2501 PN 10

d	DN	Inch	for flange adaptor metric PP-V black	for flange adaptor metric PP with steel ring				
40	32	1 ¹ / ₄	727 700 409	727 700 209				
50	40	1 ¹ / ₂	727 700 410	727 700 210				
63	50	2	727 700 411	727 700 211				
75	65	2 ¹ / ₂	727 700 412	727 700 212				
90	80	3	727 700 413	727 700 213				
110	100	4	727 700 414	727 700 214				

Outlet side

PP/PE
Outlet flange adaptor
with fusion socket
metric

d	DN	Inch	Jointing face flat PP Code	Jointing face flat PE Code	D	D ₁	Z	
40	32	1 ¹ / ₄	727 800 009	733 800 009	61	50	35	
50	40	1 ¹ / ₂	727 800 010	733 800 010	73	61	38	
63	50	2	727 800 011	733 800 011	90	76	41	
75	65	2 ¹ / ₂	727 800 012	733 800 012	106	90	49	
90	80	3	727 800 013	733 800 013	125	108	65	
110	100	4	727 800 014	733 800 014	150	130	62	

Backing flange metric
for socket fusion systems
Connecting dimension
DIN 2501 PN 10

d	DN	Inch	for outlet flange adaptor PP-V black	for outlet flange adaptor PP with steel ring				
40	32	1 ¹ / ₄	727 700 409	727 700 209				
50	40	1 ¹ / ₂	727 700 410	727 700 210				
63	50	2	727 700 411	727 700 211				
75	65	2 ¹ / ₂	727 700 412	727 700 212				
90	80	3	727 700 413	727 700 213				
110	100	4	727 700 414	727 700 214				

Component Parts for Flange Assembly, Type 369 PP

Butt Fusion System PP/PE Inlet side

	d	DN	Inch	PP Code		PE Code					
PP/PE Flange Adapter metric SDR 11	40	32	1 1/4	727 798 509		753 798 609					
	50	40	1 1/2	727 798 510		753 798 610					
	63	50	2	727 798 511		753 798 611					
	75	65	2 1/2	727 798 512		753 798 612					
	90	80	3	727 798 513		753 798 613					
	110	100	4	727 798 514		753 798 614					
	140	125	5	727 798 516		753 798 616					
	160	150	6	727 798 517		753 798 617					
	225	200	8	727 798 520		753 798 620					
	280	250	10	727 798 572		753 798 672					
	315	300	12	727 798 573		753 798 673					

	d	DN	Inch	PP Code		PE Code					
PP/PE Flange Adapter metric SDR 17,6	40	32	1 1/4	--		--					
	50	40	1 1/2	727 798 535		753 798 535					
	63	50	2	727 798 536		753 798 536					
	75	65	2 1/2	727 798 412		753 798 512					
	90	80	3	727 798 413		753 798 513					
				727 798 414		753 798 514					
	110	100	4								
	140	125	5	727 798 541		753 798 541					
	160	150	6	727 798 542		753 798 542					
	225	200	8	727 798 545		753 798 545					
	280	250	10	727 798 547		753 798 547					
	315	300	12	727 798 548		753 798 548					

	d	DN	Inch	for Flange Adapter						
				PP-V black	PP with steel ring					
Backing flange metric for butt fusion systems Connecting dimension DIN 2501 PN 10	40	32	1 1/4	727 700 409	727 700 209					
	50	40	1 1/2	727 700 410	727 700 210					
	63	50	2	727 700 411	727 700 211					
	75	65	2 1/2	727 700 412	727 700 212					
	90	80	3	727 700 513	727 700 313					
	110	100	4	727 700 514	727 700 314					
	140	125	5	727 700 516	727 700 316					
	160	150	6	727 700 517	727 700 317					
	225	200	8	727 700 520	727 700 320					
	280	250	10	727 700 522	727 700 322					
	315	300	12	727 700 523	727 700 323					

Strainers 305

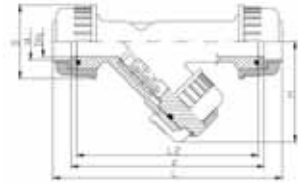

PROGEF Standard Line strainer type 305 With fusion sockets metric

Model:

- Material: PP-H
- For easy installation and removal
- Protects valves, pumps, etc. from becoming soiled
- Screen perforation 0.5 mm
- Overall length according to EN 558
- Easy dismantling for cleaning the screens

d [mm]	DN [mm]	PN	kv-value ($\Delta p=1$ bar) [l/min]	EPDM Code	FPM Code	kg	D [mm]	L [mm]	L2 [mm]	H [mm]	z [mm]
20	15	10	35	167 305 000	167 305 049	0.214	52	168	130	75	140
25	20	10	65	167 305 050	167 305 099	0.257	62	192	150	80	160
32	25	10	90	167 305 100	167 305 149	0.327	68	206	160	90	170
40	32	10	155	167 305 150	167 305 199	0.586	85	230	180	110	190
50	40	10	225	167 305 200	167 305 249	0.748	85	256	200	125	210
63	50	10	370	167 305 250	167 305 299	1.185	102	294	230	150	240

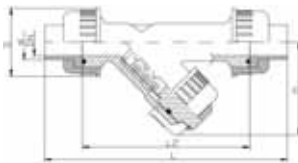

PROGEF Standard Line strainer type 305 With butt fusion spigots IR-Plus SDR11 metric

Model:

- Material: PP-H
- For easy installation and removal
- Protects valves, pumps, etc. from becoming soiled
- Screen perforation 0.5 mm
- Overall length according to EN 558
- Easy dismantling for cleaning the screens

d [mm]	DN [mm]	PN	kv-value ($\Delta p=1$ bar) [l/min]	EPDM Code	FPM Code	kg	D [mm]	L [mm]	L2 [mm]	H [mm]	e [mm]
20	15	10	35	167 305 300	167 305 349	0.219	52	238	130	75	1.9
25	20	10	65	167 305 350	167 305 399	0.268	62	264	150	80	2.3
32	25	10	90	167 305 400	167 305 449	0.354	68	280	160	90	3.0
40	32	10	155	167 305 450	167 305 499	0.660	85	306	180	110	3.7
50	40	10	225	167 305 500	167 305 549	0.816	85	332	200	125	4.6
63	50	10	370	167 305 550	167 305 599	1.295	102	368	230	150	5.8

Copiable

Configurator GF ball valve type 546 PROGEF Standard

Ball Valve

- A01 Ball Valve 546
- A02 Linear Ball Valve

Material

- B05 PP-H

Dimension

- C05 d 16 DN 10 3/8"
- C06 d 20 DN 15 1/2"
- C07 d 25 DN 20 3/4"
- C08 d 32 DN 25 1"
- C09 d 40 DN 32 1 1/4"
- C10 d 50 DN 40 1 1/2"
- C11 d 63 DN 50 2"
- C12 DN 65 2 1/2"
- C13 DN 80 3"
- C14 DN 100 4"
- C15 DN 150 6"

Version

- D01 Standard, PTFE ball seal
- D02 oilfree, PTFE ball seal (only with specific connecting parts)
- D03 silicon-free, PTFE ball seal (only with specific connecting parts)
- D04 silicon-free, PVDF ball seal for metric (only with specific connecting parts)

Seals

- E01 EPDM seals
- E02 FPM seals
- E03 FFPM/KALREZ® seals

Threaded inserts

- F01 without threaded inserts
- F02 with threaded inserts

Connecting parts

- G30 PP-H Fusion socket metric
- G32 PP-H Socket fusion spigot metric
- G33 PP-H Threaded socket Rp reinforced
- G34 PP-H Threaded socket NPT reinforced
- G35 PP-H Butt fusion spigot SDR 11 metric IR-PLUS®
- G36 PP-H Butt fusion spigot SDR 17.6 metric
with this valve end the maximum nominal pressure is reduced to PN 6
- G37 PP-H Butt fusion spigot long SDR11 metric
- G43 PE-100 Butt fusion spigot long SDR11 metric
- G44 PE-100 Butt fusion spigot long SDR17.6 metric
- G63 Fixed flange PP-H serrated metric
- G72 Backing flange PP-steel metric
- G73 Backing flange PP-steel inch ANSI
- G77 Backing flange PP JIS with connecting parts
- G78 Backing flange PP-GF JIS
- G83 PP-H Valve end blank
- G40 PE-100 Fusion socket metric
- G41 PE-100 Butt fusion spigot SDR11 metric
- G42 PE-100 Butt fusion spigot SDR17.6 metric
- G43 PE-100 Butt fusion spigot long SDR11 metric
- G11 PVC-C Cement socket metric
- G13 PVC-C Cement socket inch ASTM
- G14 PVC-C Cement spigot metric
- G15 PVC-C Threaded socket Rp
- G16 PVC-C Threaded socket Rp reinforced
- G17 PVC-C Threaded socket NPT

Multi-functional module

- I01 No multi-functional module
- I02 Empty module
- I03 Module with 2 end switches Ag, Ni
- I04 Module with 2 end switches Au
- I05 Module with 2 inductive switches Namur
- I06 Module with 2 inductive switches PNP
- I07 Module with 2 inductive switches NPN

Lever

- K01 Standard lever red
- K02 Standard lever black
- K11 Multi-functional lever red

Mounting plate

- L01 without mounting plate
- L02 with mounting plate

A01

B05

C

D

E

F

G

G

I

K

L

left

right

You will find a large selection of different versions in our range of products. New system elements also provide you with new opportunities for use. In order for us to supply exactly the ball valve you need for your application, we have created a selection menu for you. (Der maximal zulässige Betriebsdruck des Kugelhahns ist PN 10).

We supply what you put together.

Copiable GF ball valve type 546 with electric Actuator

It's so easy to actuate the type 546:

With the configurator, you have a choice of new electric actuators, the EA11 for standard applications and the EA21 with modular design and accessories, for practically any type of operation.

We supply what you put together.

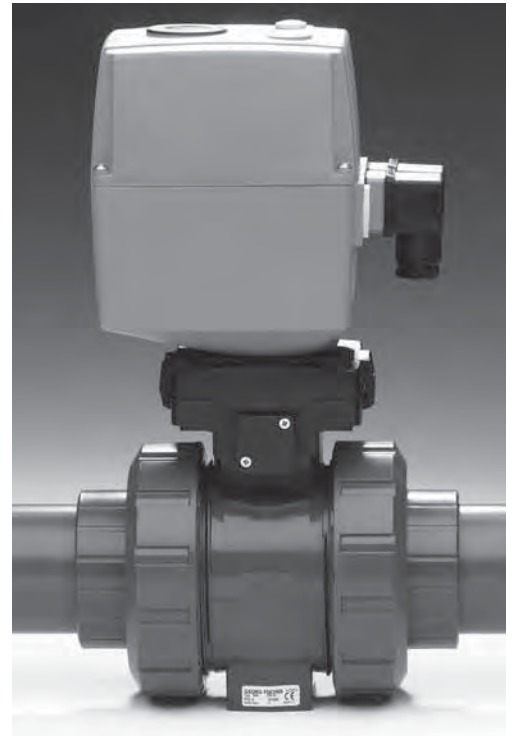

Electric Actuator EA11

- T01 EA11 24 V
- T02 EA11 100-230 V

Accessories EA11

- U01 No accessories
- U02 2 limit switches Ag, Ni
- U03 Heating element
- U04 Fail-safe return
- U05 2 limit switches Ag, Ni normally open

Electric Actuator EA21/31

- T03 EA21/31 24 V
- T04 EA21/31 100-230 V

Accessories EA21

- W01 No accessories
- W02 Heating element
- W03 Cycle time module
- W04 Cycle time monitoring
- W05 Cycles monitoring
- W06 Motor current monitoring
- W07 2 limit switches Ag, Ni
- W08 2 limit switches Gold
- W09 2 limit switches NPN
- W10 2 limit switches PNP
- W11 Positioner
- W12 Electric position indicator
- W14 Fail-safe return unit
- W15 Switch intermediate position
- W27 2 limit switches Ag, Ni normally open with connector
- W31 Positioner PE25 with galv. separation

T	U	T	W	W	W	W	W	W

Ball Valves Electric

PROGEF Standard

Ball valve type 107 100-230V

With manual emergency override

With fusion sockets metric



DN10/15 - 50

Model:

- Material: PP-H
- Built on with electric actuator EA11
- Voltage 100-230 V, 50-60 Hz
- Control range 90°<
- Control time 5 s/90°<
- For easy installation and removal
- Integrated stainless steel mounting inserts

Option:

- Individual configuration of the valve (see diagram)

d [mm]	DN [mm]	PN	kv-value ($\Delta p=1$ bar) [l/min]	EPDM Code	FPM Code	kg
16	10	10	70	199 107 502	199 107 512	2.100
20	15	10	185	199 107 503	199 107 513	2.100
25	20	10	350	199 107 504	199 107 514	2.200
32	25	10	700	199 107 505	199 107 515	2.300
40	32	10	1000	199 107 506	199 107 516	2.600
50	40	10	1600	199 107 507	199 107 517	3.000
63	50	10	3100	199 107 508	199 107 518	3.800

d [mm]	D [mm]	H [mm]	H1 [mm]	H2 [mm]	H3 [mm]	H5 [mm]	L [mm]	L1 [mm]	L2 [mm]	L4 [mm]	L5 [mm]	L6 [mm]	L7 [mm]	L8 [mm]	z [mm]
16	50	200	27	64	64	137	93	161	56	25	77	83	122	33	67
20	50	200	27	64	64	137	95	161	56	25	77	83	122	33	66
25	58	209	30	73	64	137	108	161	65	25	77	83	122	33	77
32	68	209	36	73	64	137	118	161	71	25	77	83	122	33	83
40	84	220	44	84	64	137	137	161	85	45	77	83	122	33	99
50	97	220	51	84	64	137	147	161	89	45	77	83	122	33	105
63	124	243	64	106	64	137	168	161	101	45	77	83	122	33	117

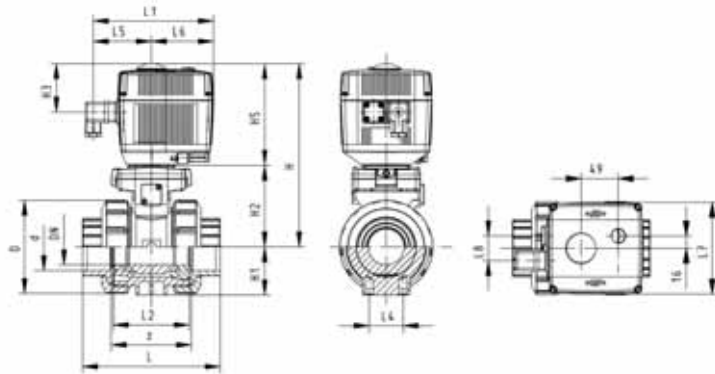



PROGEF Standard
Ball valve type 107 100-230V
With manual emergency override
With socket fusion spigots metric

Model:

- Material: PP-H
- Built on with electric actuator EA11
- Voltage 100-230 V, 50-60 Hz
- Control range 90°<
- Control time 5 s/90°<
- For easy installation and removal
- Integrated stainless steel mounting inserts

Option:

- Individual configuration of the valve (see diagram)

d [mm]	DN [mm]	PN	kv-value ($\Delta p=1$ bar) [l/min]	EPDM Code	FPM Code	kg
16	10	10	70	199 107 522	199 107 532	2.100
20	15	10	185	199 107 523	199 107 533	2.100
25	20	10	350	199 107 524	199 107 534	2.200
32	25	10	700	199 107 525	199 107 535	2.300
40	32	10	1000	199 107 526	199 107 536	2.600
50	40	10	1600	199 107 527	199 107 537	2.629
63	50	10	3100	199 107 528	199 107 538	3.800

d [mm]	D [mm]	H [mm]	H1 [mm]	H2 [mm]	H3 [mm]	H5 [mm]	L [mm]	L1 [mm]	L2 [mm]	L3 [mm]	L4 [mm]	L5 [mm]	L6 [mm]	L7 [mm]	L8 [mm]
16	50	200	27	64	64	137	110	161	56	130	25	77	83	122	33
20	50	200	27	64	64	137	120	161	56	130	25	77	83	122	33
25	58	209	30	73	64	137	139	161	65	150	25	77	83	122	33
32	68	209	36	73	64	137	150	161	71	160	25	77	83	122	33
40	84	220	44	84	64	137	170	161	85	180	45	77	83	122	33
50	97	220	51	84	64	137	190	161	89	200	45	77	83	122	33
63	124	243	64	106	64	137	220	161	101	230	45	77	83	122	33

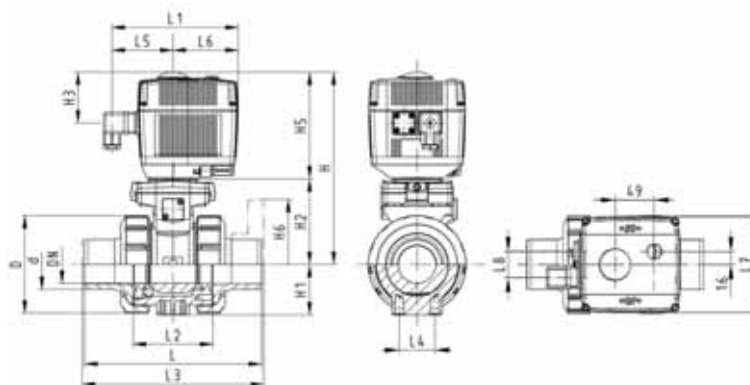



PROGEF Standard
Ball valve type 107 100-230V
With manual emergency override
With butt fusion spigots IR-Plus SDR11 metric

Model:

- Material: PP-H
- Built on with electric actuator EA11
- Voltage 100-230 V, 50-60 Hz
- Control range 90°<
- Control time 5 s/90°<
- For easy installation and removal
- Integrated stainless steel mounting inserts

Option:

- Individual configuration of the valve (see diagram)

d [mm]	DN [mm]	PN	kv-value ($\Delta p=1$ bar) [l/min]	EPDM Code	FPM Code	kg
20	15	10	185	800 046 107	800 046 110	0.000
25	20	10	350	800 046 108	800 046 112	0.000
32	25	10	700	800 027 956	800 046 113	0.000
40	32	10	1000	800 046 109	800 046 114	0.000
50	40	10	1600	800 021 699	800 046 115	0.000
63	50	10	3100	800 027 113	800 046 116	0.000

d [mm]	D [mm]	H [mm]	H1 [mm]	H2 [mm]	H3 [mm]	H5 [mm]	L [mm]	L1 [mm]	L2 [mm]	L3 [mm]	L4 [mm]	L5 [mm]	L6 [mm]	L7 [mm]	L8 [mm]
20	50	200	27	64	64	137	130	161	56	130	25	77	83	122	33
25	58	209	30	73	64	137	143	161	65	150	25	77	83	122	33
32	68	209	36	73	64	137	150	161	71	160	25	77	83	122	33
40	84	220	44	84	64	137	171	161	85	180	45	77	83	122	33
50	97	220	51	84	64	137	191	161	89	200	45	77	83	122	33
63	124	243	64	106	64	137	220	161	101	230	45	77	83	122	33

d [mm]	e [mm]
20	1.9
25	2.3
32	3.0
40	3.7
50	4.6
63	5.8

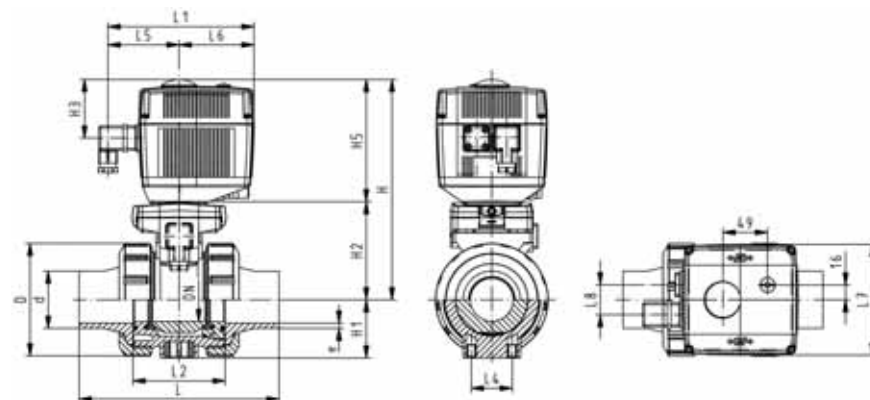



PROGEF Standard
Ball valve type 107 100-230V
With manual emergency override
With fixed flanges PP-H serrated metric

Model:

- Material: PP-H
- Built on with electric actuator EA11
- Voltage 100-230 V, 50-60 Hz
- Control range 90°<
- Control time 5 s/90°<
- For easy installation and removal
- Integrated stainless steel mounting inserts
- Overall length according to EN 558
- Connecting dimensions: ISO 7005 / EN 1092 / DIN 2501 PN10 / BS4504

Option:

- Individual configuration of the valve (see diagram)

d [mm]	DN [mm]	Inch	PN	kv-value ($\Delta p=1$ bar) [l/min]	EPDM Code	FPM Code	kg
20	15	½	10	185	199 107 583	199 107 593	2.300
25	20	¾	10	350	199 107 584	199 107 594	2.500
32	25	1	10	700	199 107 585	199 107 595	2.700
40	32	1 ¼	10	1000	199 107 586	199 107 596	3.200
50	40	1 ½	10	1600	199 107 587	199 107 597	3.700
63	50	2	10	3100	199 107 588	199 107 598	4.800

d [mm]	D [mm]	H [mm]	H1 [mm]	H2 [mm]	H3 [mm]	H5 [mm]	H6 [mm]	L [mm]	L1 [mm]	L2 [mm]	L3 [mm]	L4 [mm]	L5 [mm]	L6 [mm]	L7 [mm]
20	50	200	27	64	64	137	48	120	161	56	130	25	77	83	122
25	58	209	30	73	64	137	53	140	161	65	150	25	77	83	122
32	68	209	36	73	64	137	58	150	161	71	160	25	77	83	122
40	84	220	44	84	64	137	70	170	161	85	180	45	77	83	122
50	97	220	51	84	64	137	75	190	161	89	200	45	77	83	122
63	124	243	64	106	64	137	165	220	161	101	230	45	77	83	122

d [mm]	L8 [mm]
20	33
25	33
32	33
40	33
50	33
63	33

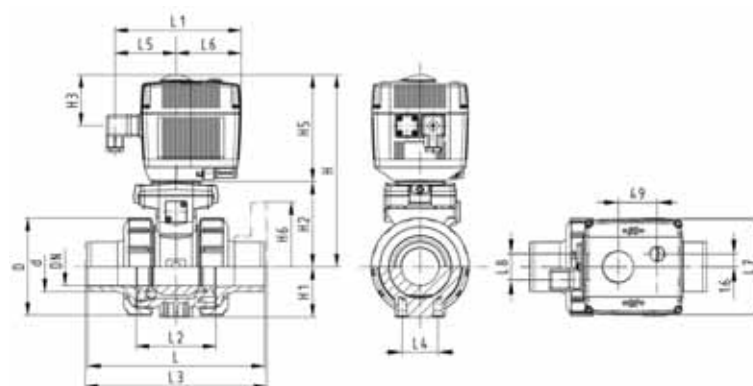



PROGEF Standard Ball valve type 107 24V With manual emergency override With fusion sockets metric

Model:

- Material: PP-H
- Built on with electric actuator EA11
- Voltage 24 V AC/DC
- Control range 90°<
- Control time 5 s/90°<
- For easy installation and removal
- Integrated stainless steel mounting inserts

Option:

- Individual configuration of the valve (see diagram)

d [mm]	DN [mm]	PN	kv-value ($\Delta p=1$ bar) [l/min]	EPDM Code	FPM Code	kg
16	10	10	70	199 107 542	199 107 552	2.100
20	15	10	185	199 107 543	199 107 553	2.100
25	20	10	350	199 107 544	199 107 554	2.200
32	25	10	700	199 107 545	199 107 555	2.241
40	32	10	1000	199 107 546	199 107 556	2.600
50	40	10	1600	199 107 547	199 107 557	3.000
63	50	10	3100	199 107 548	199 107 558	3.800

d [mm]	D [mm]	H [mm]	H1 [mm]	H2 [mm]	H3 [mm]	H5 [mm]	L [mm]	L1 [mm]	L2 [mm]	L4 [mm]	L5 [mm]	L6 [mm]	L7 [mm]	L8 [mm]	z [mm]
16	50	200	27	64	64	137	93	161	56	25	77	83	122	33	67
20	50	200	27	64	64	137	95	161	56	25	77	83	122	33	66
25	58	209	30	73	64	137	108	161	65	25	77	83	122	33	77
32	68	209	36	73	64	137	118	161	71	25	77	83	122	33	83
40	84	220	44	84	64	137	137	161	85	45	77	83	122	33	99
50	97	220	51	84	64	137	147	161	89	45	77	83	122	33	105
63	124	243	64	106	64	137	168	161	101	45	77	83	122	33	117

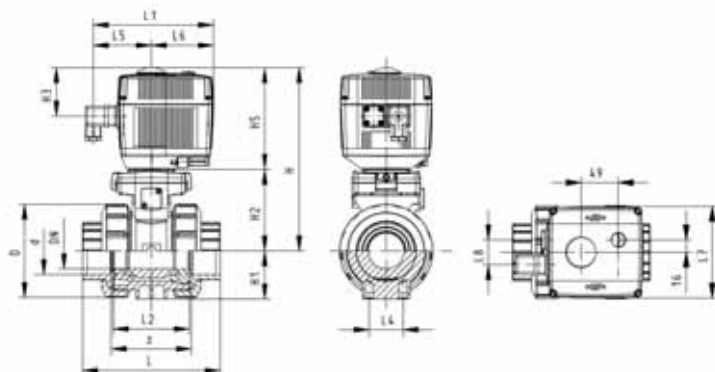



PROGEF Standard
Ball valve type 107 24V
With manual emergency override
With socket fusion spigots metric

Model:

- Material: PP-H
- Built on with electric actuator EA11
- Voltage 24 V AC/DC
- Control range 90°<
- Control time 5 s/90°<
- For easy installation and removal
- Integrated stainless steel mounting inserts

Option:

- Individual configuration of the valve (see diagram)

d [mm]	DN [mm]	PN	kv-value ($\Delta p=1$ bar) [l/min]	EPDM Code	FPM Code	kg
16	10	10	70	199 107 562	199 107 572	2.100
20	15	10	185	199 107 563	199 107 573	2.096
25	20	10	350	199 107 564	199 107 574	2.200
32	25	10	700	199 107 565	199 107 575	2.300
40	32	10	1000	199 107 566	199 107 576	2.600
50	40	10	1600	199 107 567	199 107 577	3.000
63	50	10	3100	199 107 568	199 107 578	3.800

d [mm]	D [mm]	H [mm]	H1 [mm]	H2 [mm]	H3 [mm]	H5 [mm]	L [mm]	L1 [mm]	L2 [mm]	L3 [mm]	L4 [mm]	L5 [mm]	L6 [mm]	L7 [mm]	L8 [mm]
16	50	200	27	64	64	137	110	161	56	130	25	77	83	122	33
20	50	200	27	64	64	137	120	161	56	130	25	77	83	122	33
25	58	209	30	73	64	137	139	161	65	150	25	77	83	122	33
32	68	209	36	73	64	137	156	161	71	160	25	77	83	122	33
40	84	220	44	84	64	137	170	161	85	180	45	77	83	122	33
50	97	220	51	84	64	137	190	161	89	200	45	77	83	122	33
63	124	243	64	106	64	137	220	161	101	230	45	77	83	122	33

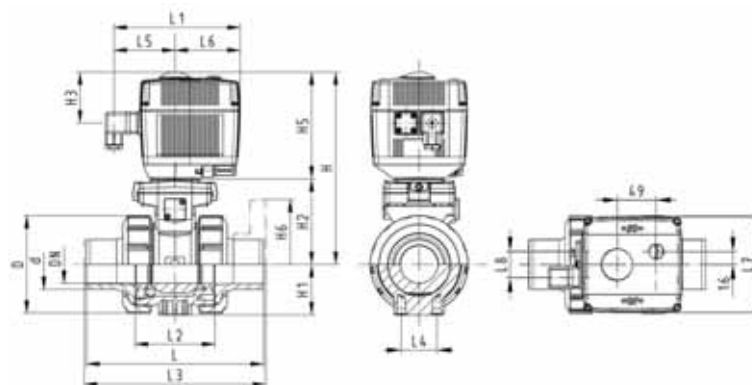



PROGEF Standard Ball valve type 107 24V With manual emergency override With butt fusion spigots IR-Plus SDR11 metric

Model:

- Material: PP-H
- Built on with electric actuator EA11
- Voltage 24 V AC/DC
- Control range 90°<
- Control time 5 s/90°<
- For easy installation and removal
- Integrated stainless steel mounting inserts

Option:

- Individual configuration of the valve (see diagram)

d [mm]	DN [mm]	PN	kv-value ($\Delta p=1$ bar) [l/min]	EPDM Code	FPM Code	kg
20	15	10	185	800 015 073	800 046 119	0.000
25	20	10	350	800 046 117	800 046 120	0.000
32	25	10	700	800 046 118	800 046 121	0.000
40	32	10	1000	800 021 702	800 046 122	0.000
50	40	10	1600	800 021 700	800 046 123	3.000
63	50	10	3100	800 021 701	800 046 124	3.910

d [mm]	D [mm]	H [mm]	H1 [mm]	H2 [mm]	H3 [mm]	H5 [mm]	L [mm]	L1 [mm]	L2 [mm]	L3 [mm]	L4 [mm]	L5 [mm]	L6 [mm]	L7 [mm]	L8 [mm]
20	50	200	27	64	64	137	130	161	56	130	25	77	83	122	33
25	58	209	30	73	64	137	143	161	65	150	25	77	83	122	33
32	68	209	36	73	64	137	150	161	71	160	25	77	83	122	33
40	84	220	44	84	64	137	171	161	85	180	45	77	83	122	33
50	97	220	51	84	64	137	191	161	89	200	45	77	83	122	33
63	124	243	64	106	64	137	220	161	101	230	45	77	83	122	33

d [mm]	e [mm]
20	1.9
25	2.3
32	3.0
40	3.7
50	4.6
63	5.8

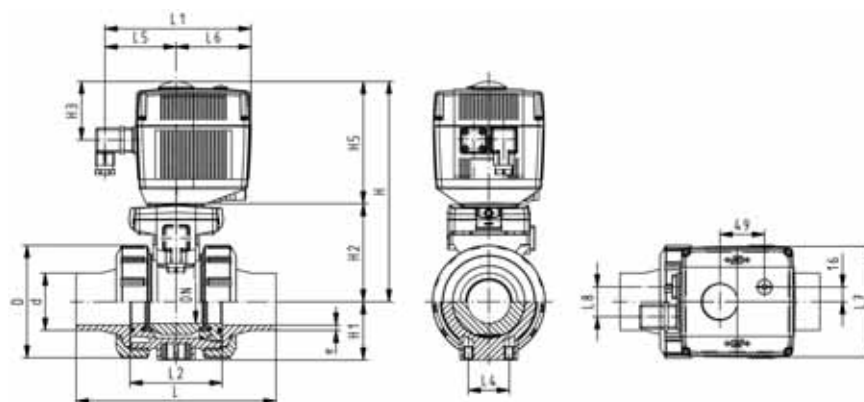



PROGEF Standard
Ball valve type 107 24V
With manual emergency override
With fixed flanges PP-H serrated metric

Model:

- Material: PP-H
- Built on with electric actuator EA11
- Voltage 24 V AC/DC
- Control range 90°<
- Control time 5 s/90°<
- For easy installation and removal
- Integrated stainless steel mounting inserts
- Overall length according to EN 558
- Connecting dimensions: ISO 7005 / EN 1092 / DIN 2501 PN10 / BS4504

Option:

- Individual configuration of the valve (see diagram)

d [mm]	DN [mm]	Inch	PN	kv-value ($\Delta p=1$ bar) [l/min]	EPDM Code	FPM Code	kg
20	15	½	10	185	199 107 783	199 107 793	2.300
25	20	¾	10	350	199 107 784	199 107 794	2.500
32	25	1	10	700	199 107 785	199 107 795	2.700
40	32	1 ¼	10	1000	199 107 786	199 107 796	3.200
50	40	1 ½	10	1600	199 107 787	199 107 797	3.700
63	50	2	10	3100	199 107 788	199 107 798	4.800

d [mm]	D [mm]	H [mm]	H1 [mm]	H2 [mm]	H3 [mm]	H5 [mm]	H6 [mm]	L [mm]	L1 [mm]	L2 [mm]	L3 [mm]	L4 [mm]	L5 [mm]	L6 [mm]	L7 [mm]
20	50	200	27	64	64	137	48	120	161	56	130	25	77	83	122
25	58	209	30	73	64	137	53	140	161	65	150	25	77	83	122
32	68	209	36	73	64	137	58	150	161	71	160	25	77	83	122
40	84	220	44	84	64	137	70	170	161	85	180	45	77	83	122
50	97	220	51	84	64	137	75	190	161	89	200	45	77	83	122
63	124	243	64	106	64	137	165	220	161	101	230	45	77	83	122

d [mm]	L8 [mm]
20	33
25	33
32	33
40	33
50	33
63	33

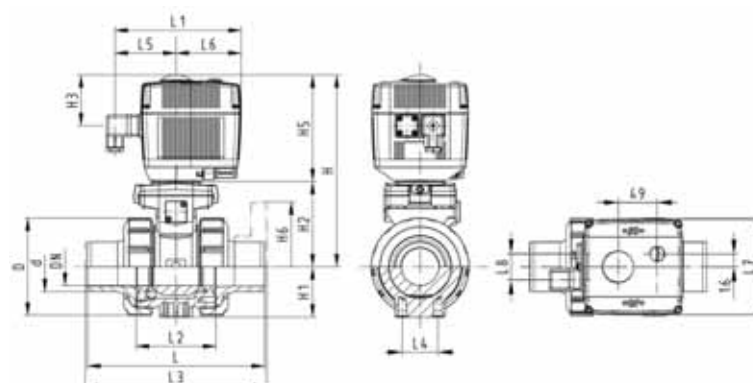



DN10/15 - 50



PROGEF Standard Ball valve type 131 100-230V With manual emergency override With fusion sockets metric

Model:

- Material: PP-H
- For easy installation and removal
- Integrated stainless steel mounting inserts
- Voltage 100-230 V, 50-60 Hz
- Control range 90°<
- Assignment of actuators: EA21 (DN10/15-50), EA31 (DN65-100)
- Control time: EA21: 5s/90°<, EA31: 15s/90°<

Option:

- Individual configuration of the valve (see diagram)

d [mm]	DN [mm]	PN	kv-value ($\Delta p=1$ bar) [l/min]	EPDM Code	FPM Code	kg
16	10	10	70	199 131 002	199 131 012	2.100
20	15	10	185	199 131 003	199 131 013	2.100
25	20	10	350	199 131 004	199 131 014	2.200
32	25	10	700	199 131 005	199 131 015	2.589
40	32	10	1000	199 131 006	199 131 016	2.600
50	40	10	1600	199 131 007	199 131 017	3.000
63	50	10	3100	199 131 008	199 131 018	3.482
75	65	10	5000	199 131 009	199 131 019	6.200
90	80	10	7000	199 131 010	199 131 020	8.000
110	100	10	11000	199 131 011	199 131 021	11.200

d [mm]	D [mm]	H [mm]	H1 [mm]	H2 [mm]	H3 [mm]	H5 [mm]	L [mm]	L1 [mm]	L2 [mm]	L4 [mm]	L5 [mm]	L7 [mm]	z [mm]
16	50	231	27	64	94	167	93	180	56	25	97	122	67
20	50	231	27	64	94	167	95	180	56	25	97	122	66
25	58	240	30	73	94	167	108	180	65	25	97	122	77
32	68	240	36	73	94	167	118	180	71	25	97	122	83
40	84	251	44	84	94	167	137	180	85	45	97	122	99
50	97	251	51	84	94	167	147	180	89	45	97	122	105
63	124	273	64	106	94	167	168	180	101	45	97	122	117
75	166	346	85	156	94	190	233	180	136	70	98	122	167
90	200	358	105	168	94	190	254	180	141	70	98	122	180
110	238	365	123	175	94	190	301	180	164	120	98	122	215

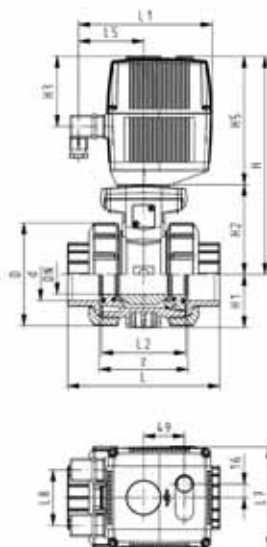

DN10/15-50

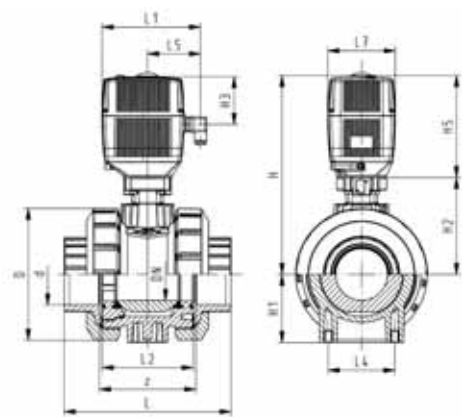

DN65-100

PROGEF Standard Ball valve type 131 100-230V With manual emergency override With socket fusion spigots metric

Model:

- Material: PP-H
- For easy installation and removal
- Integrated stainless steel mounting inserts
- Voltage 100-230 V, 50-60 Hz
- Control range 90°<
- Assignment of actuators: EA21 (DN10/15-50), EA31 (DN65-100)
- Control time: EA21: 5s/90°<, EA31: 15s/90°<

Option:

- Individual configuration of the valve (see diagram)



d [mm]	DN [mm]	PN	kv-value ($\Delta p=1$ bar) [l/min]	EPDM Code	FPM Code	kg
16	10	10	70	199 131 022	199 131 032	2.100
20	15	10	185	199 131 023	199 131 033	2.100
25	20	10	350	199 131 024	199 131 034	2.200
32	25	10	700	199 131 025	199 131 035	2.300
40	32	10	1000	199 131 026	199 131 036	2.600
50	40	10	1600	199 131 027	199 131 037	3.000
63	50	10	3100	199 131 028	199 131 038	3.800
75	65	10	5000	199 131 029	199 131 039	6.200
90	80	10	7000	199 131 030	199 131 040	8.000
110	100	10	11000	199 131 031	199 131 041	11.200

d [mm]	D [mm]	H [mm]	H1 [mm]	H2 [mm]	H3 [mm]	H5 [mm]	L [mm]	L1 [mm]	L2 [mm]	L3 [mm]	L4 [mm]	L5 [mm]	L7 [mm]
16	50	231	27	64	94	167	110	180	56	130	25	97	122
20	50	231	27	64	94	167	120	180	56	130	25	97	122
25	58	240	30	73	94	167	139	180	65	150	25	97	122
32	68	240	36	73	94	167	150	180	71	160	25	97	122
40	84	251	44	84	94	167	170	180	85	180	45	97	122
50	97	251	51	84	94	167	190	180	89	200	45	97	122
63	124	273	64	106	94	167	220	180	101	230	45	97	122
75	166	346	85	156	94	190	280	180	136	290	70	98	122
90	200	358	105	168	94	190	296	180	141	310	70	98	122
110	238	365	123	175	94	190	336	180	164	350	120	98	122

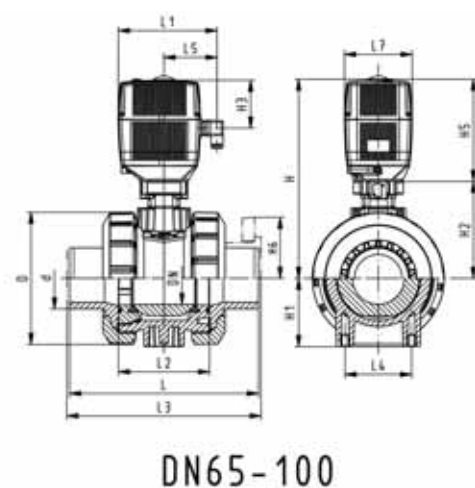
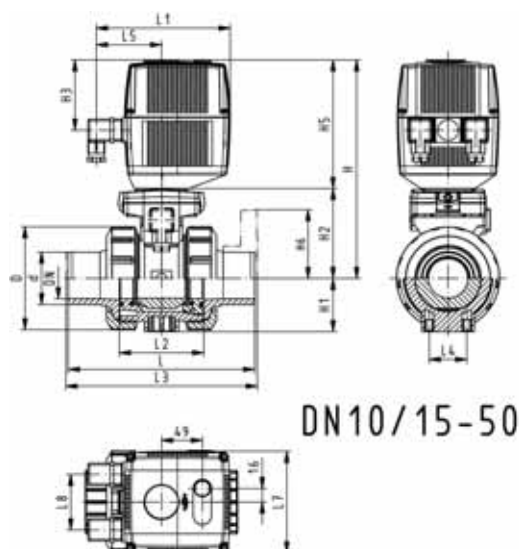



PROGEF Standard Ball valve type 131 100-230V With manual emergency override With fixed flanges PP-H serrated metric

Model:

- Material: PP-H
- For easy installation and removal
- Integrated stainless steel mounting inserts
- Voltage 100-230 V, 50-60 Hz
- Control range 90°<
- Built on with electric actuator EA21
- Control time 5 s/90°<
- Overall length according to EN 558
- Connecting dimensions: ISO 7005 / EN 1092 / DIN 2501 PN10 / BS4504

Option:

- Individual configuration of the valve (see diagram)

d [mm]	DN [mm]	Inch	PN	kv-value ($\Delta p=1$ bar) [l/min]	EPDM Code	FPM Code	kg
20	15	½	10	185	199 131 083	199 131 093	2.300
25	20	¾	10	350	199 131 084	199 131 094	2.500
32	25	1	10	700	199 131 085	199 131 095	2.700
40	32	1 ¼	10	1000	199 131 086	199 131 096	3.200
50	40	1 ½	10	1600	199 131 087	199 131 097	3.700
63	50	2	10	3100	199 131 088	199 131 098	4.800

d [mm]	D [mm]	H [mm]	H1 [mm]	H2 [mm]	H3 [mm]	H5 [mm]	H6 [mm]	L [mm]	L1 [mm]	L2 [mm]	L3 [mm]	L4 [mm]	L5 [mm]	L6 [mm]	L7 [mm]
20	50	231	27	64	94	167	48	120	180	56	130	25	97	83	122
25	58	240	30	73	94	167	53	140	180	65	150	25	97	83	122
32	68	240	36	73	94	167	58	150	180	71	160	25	97	83	122
40	84	251	44	84	94	167	70	170	180	85	180	45	97	83	122
50	97	251	51	84	94	167	75	190	180	89	200	45	97	83	122
63	124	273	64	106	94	167	165	220	180	101	230	45	97	83	122

d [mm]	L8 [mm]
20	66
25	66
32	66
40	66
50	66
63	66

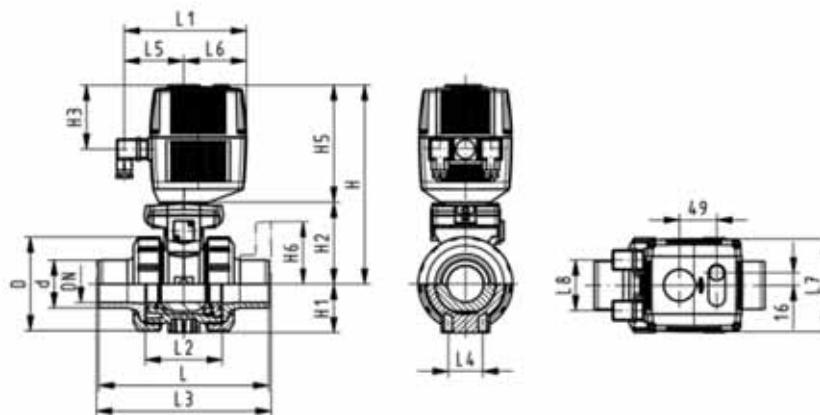



PROGEF Standard
Ball valve type 131 100-230V
With manual emergency override
With backing flanges PP-st metric

Model:

- Material: PP-H
- For easy installation and removal
- Integrated stainless steel mounting inserts
- Voltage 100-230 V, 50-60 Hz
- Control range 90°<
- Assignment of actuators: EA21 (DN10/15-50), EA31 (DN65-100)
- Control time: EA21: 5s/90°<, EA31: 15s/90°<
- Overall length according to EN 558
- Connecting dimension: ISO 7005, EN 1092, BS 4504, DIN 2501

Option:

- Individual configuration of the valve (see diagram)

d [mm]	DN [mm]	Inch	PN	kv-value ($\Delta p=1$ bar) [l/min]	EPDM Code	FPM Code	kg
75	65	2 ½	10	5000	199 131 129	199 131 139	10.500
90	80	3	10	7000	199 131 130	199 131 140	13.200
110	100	4	10	11000	199 131 131	199 131 141	18.400

d [mm]	D [mm]	H [mm]	H1 [mm]	H2 [mm]	H3 [mm]	H5 [mm]	H6 [mm]	L [mm]	L1 [mm]	L2 [mm]	L3 [mm]	L4 [mm]	L5 [mm]	L6 [mm]	L7 [mm]
75	166	346	85	156	94	190	93	280	180	136	290	70	98	83	122
90	200	358	105	168	94	190	100	296	180	141	310	70	98	83	122
110	238	365	123	175	94	190	110	336	180	164	350	120	98	83	122

d [mm]	L8 [mm]
75	66
90	66
110	66

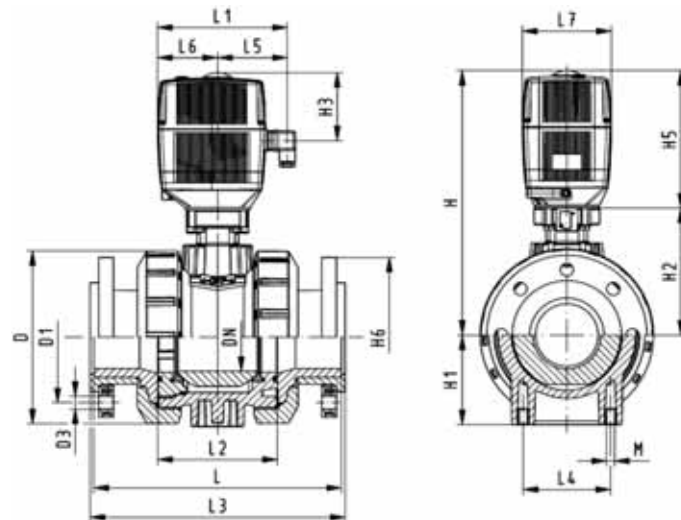



DN10/15 - 50



PROGEF Standard

Ball valve type 131 100-230V

With manual emergency override

With butt fusion spigots IR-Plus SDR11 metric

Model:

- Material: PP-H
- For easy installation and removal
- Integrated stainless steel mounting inserts
- Voltage 100-230 V, 50-60 Hz
- Control range 90°<
- Assignment of actuators: EA21 (DN10/15-50), EA31 (DN65-100)
- Control time: EA21: 5s/90°<, EA31: 15s/90°<

Option:

- Individual configuration of the valve (see diagram)

d [mm]	DN [mm]	PN	kv-value (Δp=1 bar) [l/min]	EPDM Code	FPM Code	kg
75	65	10	5000	199 131 329	199 131 339	6.200
90	80	10	7000	199 131 330	199 131 340	8.000
110	100	10	11000	199 131 331	199 131 341	11.200

d [mm]	D [mm]	H [mm]	H1 [mm]	H2 [mm]	H3 [mm]	H5 [mm]	L [mm]	L1 [mm]	L2 [mm]	L3 [mm]	L4 [mm]	L5 [mm]	L7 [mm]	e [mm]
75	166	346	85	156	94	190	266	180	136	290	70	98	122	8.2
90	200	358	105	168	94	190	264	180	141	310	70	98	122	9.9
110	238	365	123	175	94	190	301	180	164	350	120	98	122	12.0

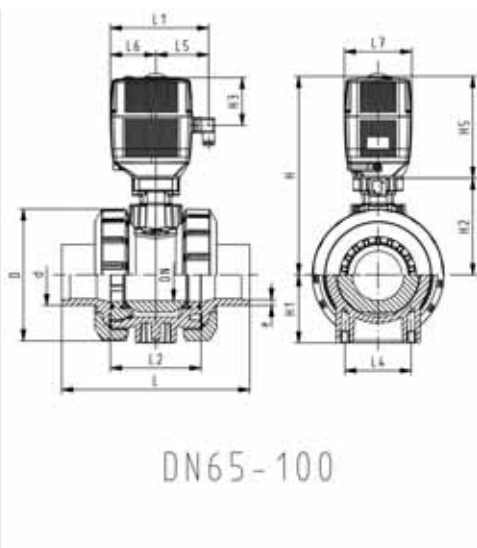
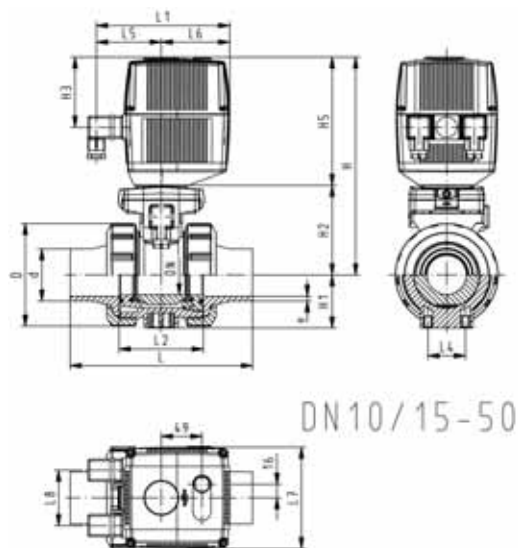

PROGEF Standard

Ball valve type 131 100-230V

With manual emergency override

With butt fusion spigots SDR17.6 metric



Model:

- Material: PP-H
- For easy installation and removal
- Integrated stainless steel mounting inserts
- Voltage 100-230 V, 50-60 Hz
- Control range 90°<
- Assignment of actuators: EA21 (DN10/15-50), EA31 (DN65-100)
- Control time: EA21: 5s/90°<, EA31: 15s/90°<

Option:

- Individual configuration of the valve (see diagram)

d [mm]	DN [mm]	PN	kv-value (Δp=1 bar) [l/min]	EPDM Code	FPM Code	kg
75	65	10	5000	199 131 729	199 131 739	6.200
90	80	10	7000	199 131 730	199 131 740	8.000
110	100	10	11000	199 131 731	199 131 741	11.200

d [mm]	D [mm]	H [mm]	H1 [mm]	H2 [mm]	H3 [mm]	H5 [mm]	L [mm]	L1 [mm]	L2 [mm]	L3 [mm]	L4 [mm]	L5 [mm]	L7 [mm]	e [mm]
75	166	346	85	156	94	190	266	180	136	290	70	98	122	4.6
90	200	358	105	168	94	190	264	180	141	310	70	98	122	5.5
110	238	365	123	175	94	190	301	180	164	350	120	98	122	6.7

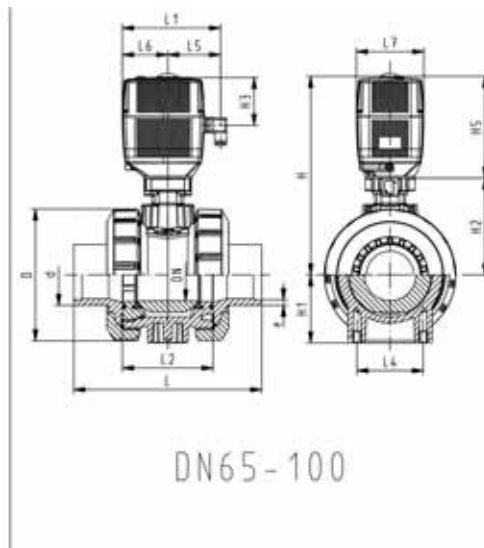
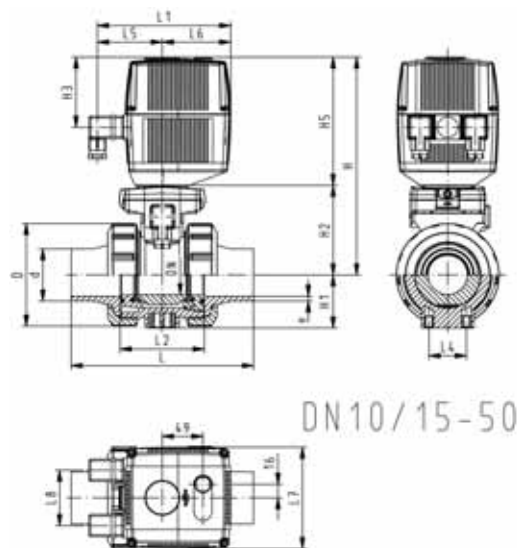



DN10/15 - 50



PROGEF Standard Ball valve type 131 24V With manual emergency override With fusion sockets metric

Model:

- Material: PP-H
- For easy installation and removal
- Integrated stainless steel mounting inserts
- Voltage 24 V AC/DC
- Control range 90°<
- Assignment of actuators: EA21 (DN10/15-50), EA31 (DN65-100)
- Control time: EA21: 5s/90°<, EA31: 15s/90°<

Option:

- Individual configuration of the valve (see diagram)

d [mm]	DN [mm]	PN	kv-value ($\Delta p=1$ bar) [l/min]	EPDM Code	FPM Code	kg
16	10	10	70	199 131 042	199 131 052	2.100
20	15	10	185	199 131 043	199 131 053	2.100
25	20	10	350	199 131 044	199 131 054	2.200
32	25	10	700	199 131 045	199 131 055	2.300
40	32	10	1000	199 131 046	199 131 056	2.600
50	40	10	1600	199 131 047	199 131 057	3.000
63	50	10	3100	199 131 048	199 131 058	3.460
75	65	10	5000	199 131 049	199 131 059	6.200
90	80	10	7000	199 131 050	199 131 060	8.000
110	100	10	11000	199 131 051	199 131 061	11.200

d [mm]	D [mm]	H [mm]	H1 [mm]	H2 [mm]	H3 [mm]	H5 [mm]	L [mm]	L1 [mm]	L2 [mm]	L4 [mm]	L5 [mm]	L7 [mm]	z [mm]
16	50	231	27	64	94	167	93	180	56	25	97	122	67
20	50	231	27	64	94	167	95	180	56	25	97	122	66
25	58	240	30	73	94	167	108	180	65	25	97	122	77
32	68	240	36	73	94	167	118	180	71	25	97	122	83
40	84	251	44	84	94	167	137	180	85	45	97	122	99
50	97	251	51	84	94	167	147	180	89	45	97	122	105
63	124	273	64	106	94	167	168	180	101	45	97	122	117
75	166	346	85	156	94	190	233	180	136	70	98	122	167
90	200	358	105	168	94	190	254	180	141	70	98	122	180
110	238	365	123	175	94	190	301	180	164	120	98	122	215

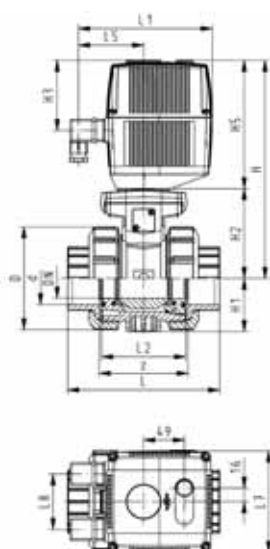

DN10/15-50

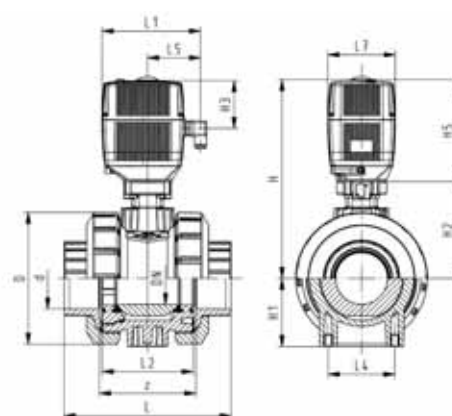

DN65-100

PROGEF Standard Ball valve type 131 24V With manual emergency override With socket fusion spigots metric



Model:

- Material: PP-H
- For easy installation and removal
- Integrated stainless steel mounting inserts
- Voltage 24 V AC/DC
- Control range 90°<
- Assignment of actuators: EA21 (DN10/15-50), EA31 (DN65-100)
- Control time: EA21: 5s/90°<, EA31: 15s/90°<

Option:

- Individual configuration of the valve (see diagram)

d [mm]	DN [mm]	PN	kv-value ($\Delta p=1$ bar) [l/min]	EPDM Code	FPM Code	kg
16	10	10	70	199 131 062	199 131 072	2.100
20	15	10	185	199 131 063	199 131 073	2.100
25	20	10	350	199 131 064	199 131 074	2.200
32	25	10	700	199 131 065	199 131 075	2.300
40	32	10	1000	199 131 066	199 131 076	2.600
50	40	10	1600	199 131 067	199 131 077	3.000
63	50	10	3100	199 131 068	199 131 078	3.800
75	65	10	5000	199 131 069	199 131 079	6.200
90	80	10	7000	199 131 070	199 131 080	8.000
110	100	10	11000	199 131 071	199 131 081	11.200

d [mm]	D [mm]	H [mm]	H1 [mm]	H2 [mm]	H3 [mm]	H5 [mm]	L [mm]	L1 [mm]	L2 [mm]	L3 [mm]	L4 [mm]	L5 [mm]	L7 [mm]
16	50	231	27	64	94	167	110	180	56	130	25	97	122
20	50	231	27	64	94	167	120	180	56	130	25	97	122
25	58	240	30	73	94	167	139	180	65	150	25	97	122
32	68	240	36	73	94	167	150	180	71	160	25	97	122
40	84	251	44	84	94	167	170	180	85	180	45	97	122
50	97	251	51	84	94	167	190	180	89	200	45	97	122
63	124	273	64	106	94	167	220	180	101	230	45	97	122
75	166	346	85	156	94	190	280	180	136	290	70	98	122
90	200	358	105	168	94	190	296	180	141	310	70	98	122
110	238	365	123	175	94	190	336	180	164	350	120	98	122

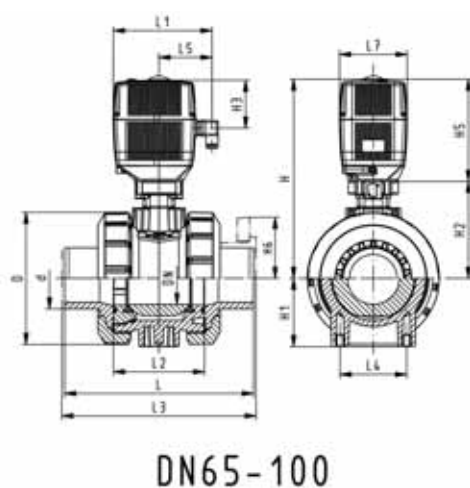
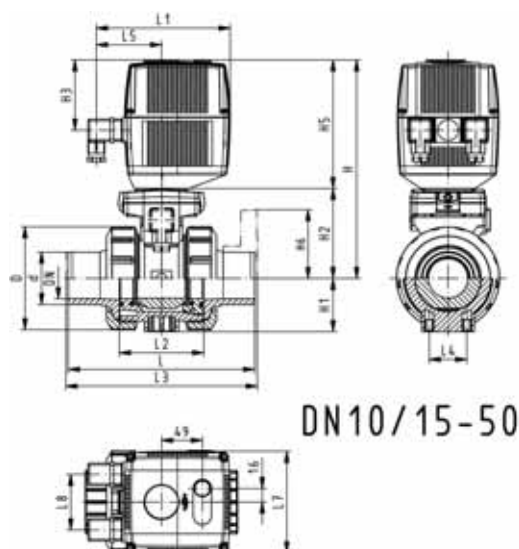



PROGEF Standard Ball valve type 131 24V With manual emergency override With fixed flanges PP-H serrated metric

Model:

- Material: PP-H
- For easy installation and removal
- Integrated stainless steel mounting inserts
- Voltage 24 V AC/DC
- Control range 90°<
- Built on with electric actuator EA21
- Control time 5 s/90°<
- Overall length according to EN 558
- Connecting dimensions: ISO 7005 / EN 1092 / DIN 2501 PN10 / BS4504

Option:

- Individual configuration of the valve (see diagram)

d [mm]	DN [mm]	Inch	PN	kv-value ($\Delta p=1$ bar) [l/min]	EPDM Code	FPM Code	kg
20	15	½	10	185	199 131 103	199 131 113	2.300
25	20	¾	10	350	199 131 104	199 131 114	2.500
32	25	1	10	700	199 131 105	199 131 115	2.700
40	32	1 ¼	10	1000	199 131 106	199 131 116	3.200
50	40	1 ½	10	1600	199 131 107	199 131 117	3.700
63	50	2	10	3100	199 131 108	199 131 118	4.800

d [mm]	D [mm]	H [mm]	H1 [mm]	H2 [mm]	H3 [mm]	H5 [mm]	H6 [mm]	L [mm]	L1 [mm]	L2 [mm]	L3 [mm]	L4 [mm]	L5 [mm]	L6 [mm]	L7 [mm]
20	50	231	27	64	94	167	48	120	180	56	130	25	97	83	122
25	58	240	30	73	94	167	53	140	180	65	150	25	97	83	122
32	68	240	36	73	94	167	58	150	180	71	160	25	97	83	122
40	84	251	44	84	94	167	70	170	180	85	180	45	97	83	122
50	97	251	51	84	94	167	75	190	180	89	200	45	97	83	122
63	124	273	64	106	94	167	165	220	180	101	230	45	97	83	122

d [mm]	L8 [mm]
20	66
25	66
32	66
40	66
50	66
63	66

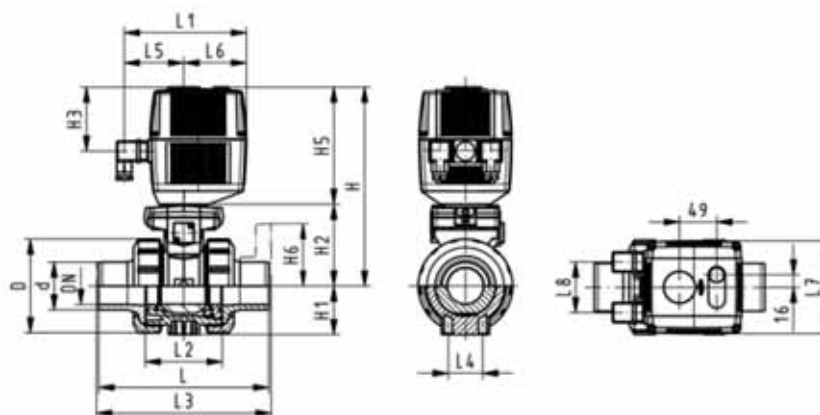



PROGEF Standard Ball valve type 131 24V With manual emergency override With backing flanges PP-st metric

Model:

- Material: PP-H
- For easy installation and removal
- Integrated stainless steel mounting inserts
- Voltage 24 V AC/DC
- Control range 90°<
- Assignment of actuators: EA21 (DN10/15-50), EA31 (DN65-100)
- Control time: EA21: 5s/90°<, EA31: 15s/90°<
- Overall length according to EN 558
- Connecting dimension: ISO 7005, EN 1092, BS 4504, DIN 2501

Option:

- Individual configuration of the valve (see diagram)

d [mm]	DN [mm]	Inch	PN	kv-value ($\Delta p=1$ bar) [l/min]	EPDM Code	FPM Code	kg
75	65	2 ½	10	5000	199 131 149	199 131 159	10.500
90	80	3	10	7000	199 131 150	199 131 160	13.200
110	100	4	10	11000	199 131 151	199 131 161	18.400

d [mm]	D [mm]	H [mm]	H1 [mm]	H2 [mm]	H3 [mm]	H5 [mm]	H6 [mm]	L [mm]	L1 [mm]	L2 [mm]	L3 [mm]	L4 [mm]	L5 [mm]	L6 [mm]	L7 [mm]
75	166	346	85	156	94	190	93	280	180	136	290	70	98	83	122
90	200	358	105	168	94	190	100	296	180	141	310	70	98	83	122
110	238	365	123	175	94	190	110	336	180	164	350	120	98	83	122

d [mm]	L8 [mm]
75	66
90	66
110	66

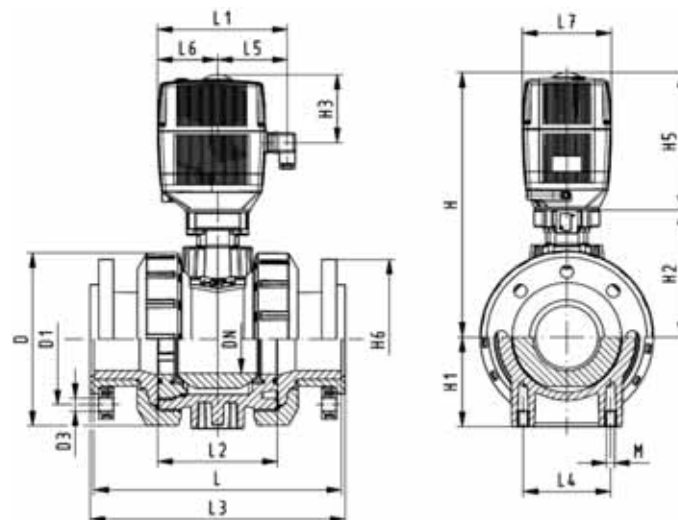



DN10/15 - 50

PROGEF Standard

Ball valve type 131 24V

With manual emergency override

With butt fusion spigots IR-Plus SDR11 metric

Model:

- Material: PP-H
- For easy installation and removal
- Integrated stainless steel mounting inserts
- Voltage 24 V AC/DC
- Control range 90°<
- Assignment of actuators: EA21 (DN10/15-50), EA31 (DN65-100)
- Control time: EA21: 5s/90°<, EA31: 15s/90°<

Option:

- Individual configuration of the valve (see diagram)



d [mm]	DN [mm]	PN	kv-value ($\Delta p=1$ bar) [l/min]	EPDM Code	FPM Code	kg
20	15	10	185	199 131 363	199 131 373	2.100
25	20	10	350	199 131 364	199 131 374	2.200
32	25	10	700	199 131 365	199 131 375	2.300
40	32	10	1000	199 131 366	199 131 376	2.600
50	40	10	1600	199 131 367	199 131 377	3.000
63	50	10	3100	199 131 368	199 131 378	3.800
75	65	10	5000	199 131 369	199 131 379	6.200
90	80	10	7000	199 131 370	199 131 380	8.000
110	100	10	11000	199 131 371	199 131 381	11.200

d [mm]	D [mm]	H [mm]	H1 [mm]	H2 [mm]	H3 [mm]	H5 [mm]	L [mm]	L1 [mm]	L2 [mm]	L3 [mm]	L4 [mm]	L5 [mm]	L7 [mm]	e [mm]
20	50	231	27	64	94	167	130	180	56	130	25	97	122	1.9
25	58	240	30	73	94	167	143	180	65	150	25	97	122	2.3
32	68	240	36	73	94	167	150	180	71	160	25	97	122	3.0
40	84	251	44	84	94	167	171	180	85	180	45	97	122	3.7
50	97	251	51	84	94	167	191	180	89	200	45	97	122	4.6
63	124	273	64	106	94	167	220	180	101	230	45	97	122	5.8
75	166	346	85	156	94	190	266	180	136	290	70	98	122	8.2
90	200	358	105	168	94	190	264	180	141	310	70	98	122	9.9
110	238	365	123	175	94	190	301	180	164	350	120	98	122	12.0

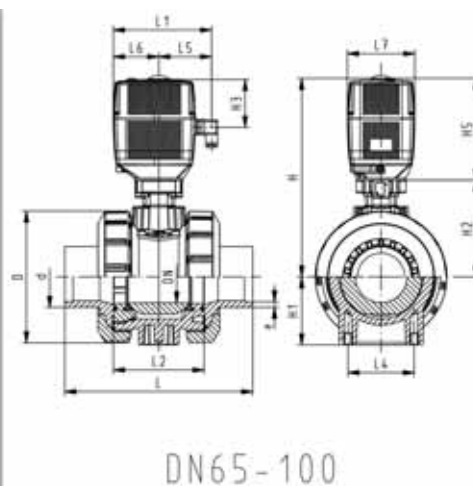
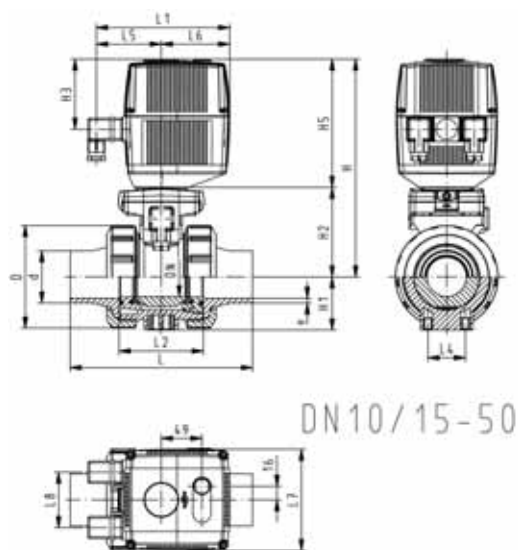

PROGEF Standard

Ball valve type 131 24V

With manual emergency override

With butt fusion spigots SDR17.6 metric



Model:

- Material: PP-H
- For easy installation and removal
- Integrated stainless steel mounting inserts
- Voltage 24 V AC/DC
- Control range 90°<
- Assignment of actuators: EA21 (DN10/15-50), EA31 (DN65-100)
- Control time: EA21: 5s/90°<, EA31: 15s/90°<

Option:

- Individual configuration of the valve (see diagram)

d [mm]	DN [mm]	PN	kv-value (Δp=1 bar) [l/min]	EPDM Code	FPM Code	kg
50	40	10	1600	199 131 767	199 131 777	6.200
63	50	10	3100	199 131 768	199 131 778	
75	65	10	5000	199 131 769	199 131 779	
90	80	10	7000	199 131 770	199 131 780	8.000
110	100	10	11000	199 131 771	199 131 781	11.200

d [mm]	D [mm]	H [mm]	H1 [mm]	H2 [mm]	H3 [mm]	H5 [mm]	L [mm]	L1 [mm]	L2 [mm]	L3 [mm]	L4 [mm]	L5 [mm]	L7 [mm]	e [mm]
50	97	251	51	84	94	167	191	180	89	200	45	97	122	2.9
63	124	273	64	106	94	167	220	180	101	230	45	97	122	3.6
75	166	346	85	156	94	190	266	180	136	290	70	98	122	4.6
90	200	358	105	168	94	190	264	180	141	310	70	98	122	5.5
110	238	365	123	175	94	190	301	180	164	350	120	98	122	6.7

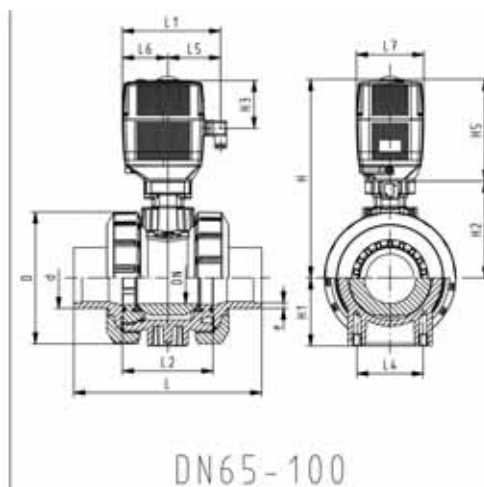
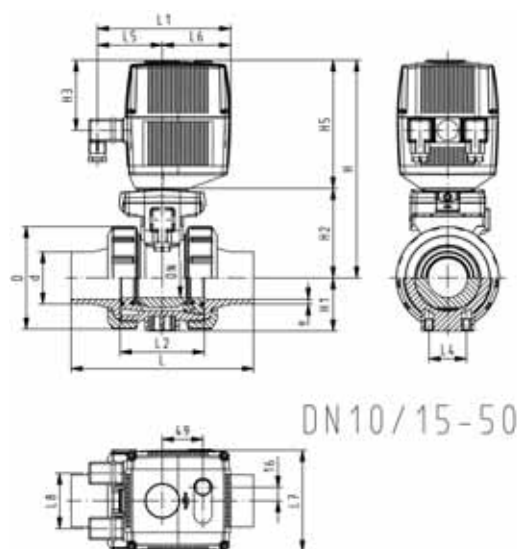



PROGEF Standard Ball valve type 131 100-230V With manual emergency override With backing flanges PP-st Inch ANSI

Model:

- Material: PP-H
- For easy installation and removal
- Voltage 100-230 V, 50-60 Hz
- Control range 90°<
- Integrated stainless steel mounting inserts
- Assignment of actuators: EA21 (DN10/15-50), EA31 (DN65-100)
- Control time: EA21: 5s/90°<, EA31: 15s/90°<
- Overall length according to EN 558
- Connecting dimension ANSI/ASME B 16.5 / ASTM D 4024

Option:

- Individual configuration of the valve (see diagram)

d [mm]	DN [mm]	Inch	PN	kv-value ($\Delta p=1$ bar) [l/min]	EPDM Code	FPM Code	kg
75	65	2 ½	10	5000	199 131 529	199 131 539	10.500
90	80	3	10	7000	199 131 530	199 131 540	13.200
110	100	4	10	11000	199 131 531	199 131 541	18.400

d [mm]	D [mm]	H [mm]	H1 [mm]	H2 [mm]	H3 [mm]	H5 [mm]	H6 [mm]	L [mm]	L1 [mm]	L2 [mm]	L3 [mm]	L4 [mm]	L5 [mm]	L6 [mm]	L7 [mm]
75	166	346	85	156	94	190	93	280	180	136	290	70	98	83	122
90	200	358	105	168	94	190	100	296	180	141	310	70	98	83	122
110	238	365	123	175	94	190	110	336	180	164	350	120	98	83	122

d [mm]	L8 [mm]
75	66
90	66
110	66

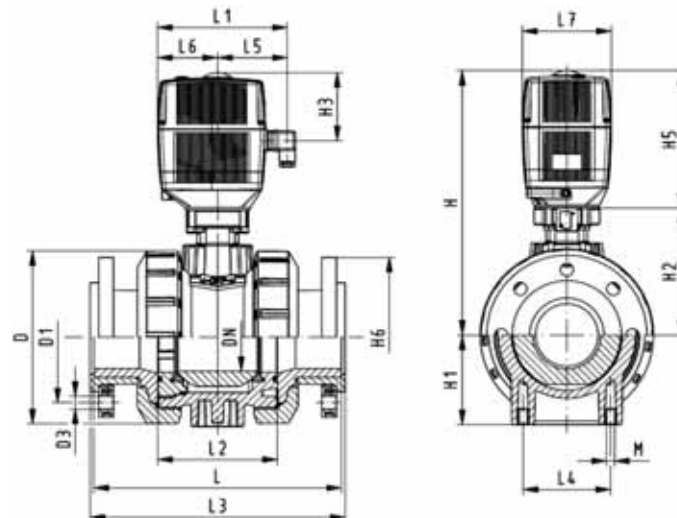



DN10/15 - 50

PROGEF Standard Ball valve type 131 100-230V With manual emergency override With threaded sockets reinforced NPT

Model:

- Material: PP-H
- For easy installation and removal
- Voltage 100-230 V, 50-60 Hz
- Control range 90°<
- Integrated stainless steel mounting inserts
- Built on with electric actuator EA21
- Control time 5 s/90°<

Option:

- Individual configuration of the valve (see diagram)

Inch	DN [mm]	PN	kv-value ($\Delta p=1$ bar) [l/min]	EPDM Code	FPM Code	kg
3/8	10	10	70	199 131 402	199 131 412	2.100
1/2	15	10	185	199 131 403	199 131 413	2.100
3/4	20	10	350	199 131 404	199 131 414	2.200
1	25	10	700	199 131 405	199 131 415	2.300
1 1/4	32	10	1000	199 131 406	199 131 416	2.600
1 1/2	40	10	1600	199 131 407	199 131 417	3.000
2	50	10	3100	199 131 408	199 131 418	4.285

Inch	D [mm]	H [mm]	H1 [mm]	H2 [mm]	H3 [mm]	H5 [mm]	L [mm]	L1 [mm]	L2 [mm]	L4 [mm]	L5 [mm]	L6 [mm]	L7 [mm]	z [mm]
3/8	50	231	27	64	94	167	96	180	56	25	97	83	122	71
1/2	50	231	27	64	94	167	99	180	56	25	97	83	122	64
3/4	58	240	30	73	94	167	111	180	65	25	97	83	122	76
1	68	240	36	73	94	167	127	180	71	25	97	83	122	83
1 1/4	84	251	44	84	94	167	146	180	85	45	97	83	122	100
1 1/2	97	251	51	84	94	167	157	180	89	45	97	83	122	111
2	124	273	64	106	94	167	183	180	101	45	97	83	122	134

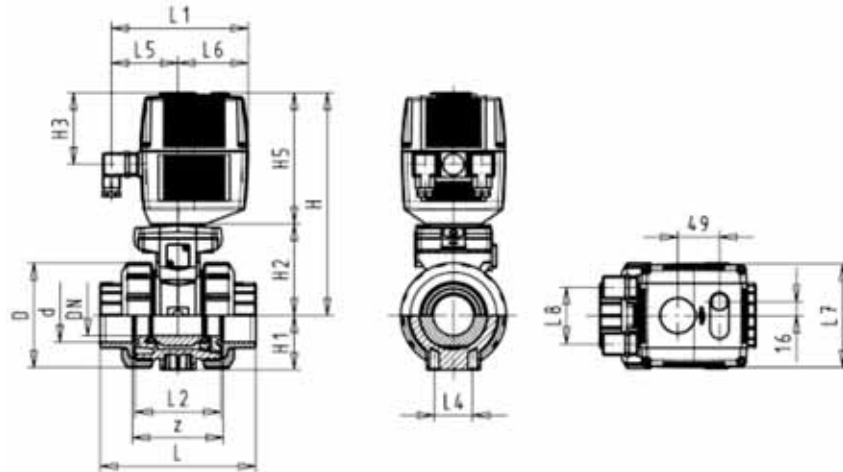



PROGEF Standard Ball valve type 131 24V With manual emergency override With backing flanges PP-st Inch ANSI

Model:

- Material: PP-H
- Voltage 24 V AC/DC
- Control range 90°<
- For easy installation and removal
- Integrated stainless steel mounting inserts
- Assignment of actuators: EA21 (DN10/15-50), EA31 (DN65-100)
- Control time: EA21: 5s/90°<, EA31: 15s/90°<
- Overall length according to EN 558
- Connecting dimension ANSI/ASME B 16.5 / ASTM D 4024

Option:

- Individual configuration of the valve (see diagram)

d [mm]	DN [mm]	Inch	PN	kv-value ($\Delta p=1$ bar) [l/min]	EPDM Code	FPM Code	kg
75	65	2 ½	10	5000	199 131 549	199 131 559	10.500
90	80	3	10	7000	199 131 550	199 131 560	13.200
110	100	4	10	11000	199 131 551	199 131 561	18.400

d [mm]	D [mm]	H [mm]	H1 [mm]	H2 [mm]	H3 [mm]	H5 [mm]	H6 [mm]	L [mm]	L1 [mm]	L2 [mm]	L3 [mm]	L4 [mm]	L5 [mm]	L6 [mm]	L7 [mm]
75	166	346	85	156	94	190	93	280	180	136	290	70	98	83	122
90	200	358	105	168	94	190	100	296	180	141	310	70	98	83	122
110	238	365	123	175	94	190	110	336	180	164	350	120	98	83	122

d [mm]	L8 [mm]
75	66
90	66
110	66

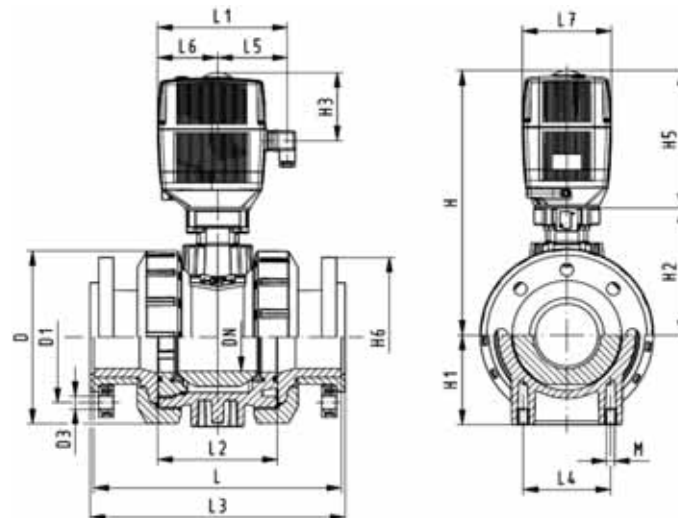



DN10/15 - 50

PROGEF Standard Ball valve type 131 24V With manual emergency override With threaded sockets verstärkt NPT

Model:

- Material: PP-H
- Voltage 24 V AC/DC
- Control range 90°<
- For easy installation and removal
- Integrated stainless steel mounting inserts
- Built on with electric actuator EA21
- Control time 5 s/90°<

Option:

- Individual configuration of the valve (see diagram)

Inch	DN [mm]	PN	kv-value ($\Delta p=1$ bar) [l/min]	EPDM Code	FPM Code	kg
3/8	10	10	70	199 131 422	199 131 432	2.100
1/2	15	10	185	199 131 423	199 131 433	2.100
3/4	20	10	350	199 131 424	199 131 434	2.200
1	25	10	700	199 131 425	199 131 435	2.300
1 1/4	32	10	1000	199 131 426	199 131 436	2.600
1 1/2	40	10	1600	199 131 427	199 131 437	3.000
2	50	10	3100	199 131 428	199 131 438	3.800

Inch	D [mm]	H [mm]	H1 [mm]	H2 [mm]	H3 [mm]	H5 [mm]	L [mm]	L1 [mm]	L2 [mm]	L4 [mm]	L5 [mm]	L6 [mm]	L7 [mm]	z [mm]
3/8	50	231	27	64	94	167	96	180	56	25	97	83	122	71
1/2	50	231	27	64	94	167	99	180	56	25	97	83	122	64
3/4	58	240	30	73	94	167	111	180	65	25	97	83	122	76
1	68	240	36	73	94	167	127	180	71	25	97	83	122	83
1 1/4	84	251	44	84	94	167	146	180	85	45	97	83	122	100
1 1/2	97	251	51	84	94	167	157	180	89	45	97	83	122	111
2	124	273	64	106	94	167	183	180	101	45	97	83	122	134

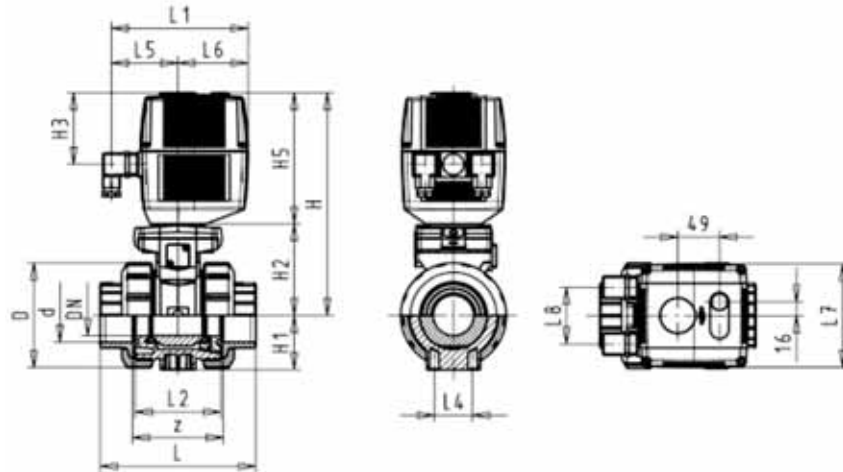



PROGEF Standard
3-Way ball valve type 186
Horizontal/L-port 100-230V
With manual emergency override
With fusion sockets metric

Model:

- Material: PP-H
- Built on with electric actuator EA21
- Voltage 100-230 V, 50-60 Hz
- Control range 90°<
- Basic position A-C opened, activated position B-C opened, see flow scheme
- Other positions possible by adjusting the limit switches
- Control time 5 s/90°<
- For easy installation and removal
- Integrated stainless steel mounting inserts

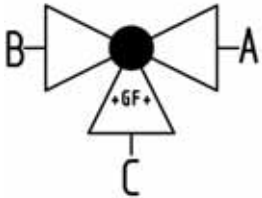

d [mm]	DN [mm]	PN	kv-value ($\Delta p=1$ bar) [l/min]	EPDM Code	FPM Code	kg
16	10	10	50	199 186 022	199 186 032	2.038
20	15	10	75	199 186 023	199 186 033	2.042
25	20	10	150	199 186 024	199 186 034	2.132
32	25	10	280	199 186 025	199 186 035	2.257
40	32	10	480	199 186 026	199 186 036	2.548
50	40	10	620	199 186 027	199 186 037	2.844
63	50	10	1230	199 186 028	199 186 038	3.751

d [mm]	D [mm]	H [mm]	H1 [mm]	H2 [mm]	H3 [mm]	H5 [mm]	H6 [mm]	L [mm]	L1 [mm]	L2 [mm]	L3 [mm]	L4 [mm]	L5 [mm]	L6 [mm]	L7 [mm]
16	50	231	28	64	94	167	8	110	180	72	36	25	97	83	122
20	50	231	28	64	94	167	8	112	180	72	36	25	97	83	122
25	58	240	32	73	94	167	8	129	180	85	43	25	97	83	122
32	68	240	36	73	94	167	8	146	180	98	49	25	97	83	122
40	84	251	45	84	94	167	9	170	180	118	59	45	97	83	122
50	97	251	51	84	94	167	9	193	180	135	68	45	97	83	122
63	124	273	65	106	94	167	9	244	180	176	88	45	97	83	122

d [mm]	L8 [mm]	M	z [mm]	z1 [mm]
16	33	6	82	41
20	33	6	82	41
25	33	6	97	49
32	33	6	110	55
40	33	8	132	66
50	33	8	151	76
63	33	8	188	94

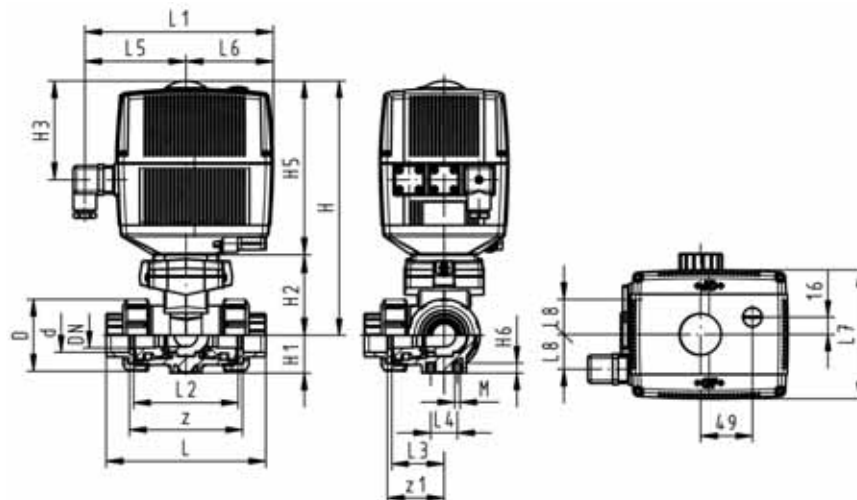



PROGEF Standard
3-Way ball valve type 186
Horizontal/L-port 100-230V
With manual emergency override
With threaded sockets reinforced Rp

Model:

- Material: PP-H
- Built on with electric actuator EA21
- Voltage 100-230 V, 50-60 Hz
- Control range 90°<
- Basic position A-C opened, activated position B-C opened, see flow scheme
- Other positions possible by adjusting the limit switches
- Control time 5 s/90°<
- For easy installation and removal
- Integrated stainless steel mounting inserts

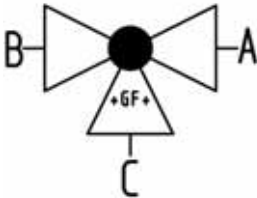

Rp [inch]	DN [mm]	PN	kv-value (Δp=1 bar) [l/min]	EPDM Code	FPM Code	kg
3/8	10	10	50	199 186 122	199 186 132	2.038
1/2	15	10	75	199 186 123	199 186 133	2.042
3/4	20	10	150	199 186 124	199 186 134	2.132
1	25	10	280	199 186 125	199 186 135	2.257
1 1/4	32	10	480	199 186 126	199 186 136	2.548
1 1/2	40	10	620	199 186 127	199 186 137	2.844
2	50	10	1230	199 186 128	199 186 138	3.751

Rp [inch]	D [mm]	H [mm]	H1 [mm]	H2 [mm]	H3 [mm]	H5 [mm]	H6 [mm]	L [mm]	L1 [mm]	L2 [mm]	L3 [mm]	L4 [mm]	L5 [mm]	L6 [mm]	L7 [mm]
3/8	50	231	28	64	94	167	8	112	180	72	36	25	97	83	122
1/2	50	231	28	64	94	167	8	114	180	72	36	25	97	83	122
3/4	58	240	32	73	94	167	8	131	180	85	43	25	97	83	122
1	68	240	36	73	94	167	8	154	180	98	49	25	97	83	122
1 1/4	84	251	45	84	94	167	9	180	180	118	59	45	97	83	122
1 1/2	97	251	51	84	94	167	9	203	180	135	68	45	97	83	122
2	124	273	65	106	94	167	9	258	180	176	88	45	97	83	122

Rp [inch]	L8 [mm]	M	z [mm]	z1 [mm]
3/8	33	6	86	43
1/2	33	6	84	42
3/4	33	6	99	50
1	33	6	112	56
1 1/4	33	8	132	66
1 1/2	33	8	153	77
2	33	8	196	98

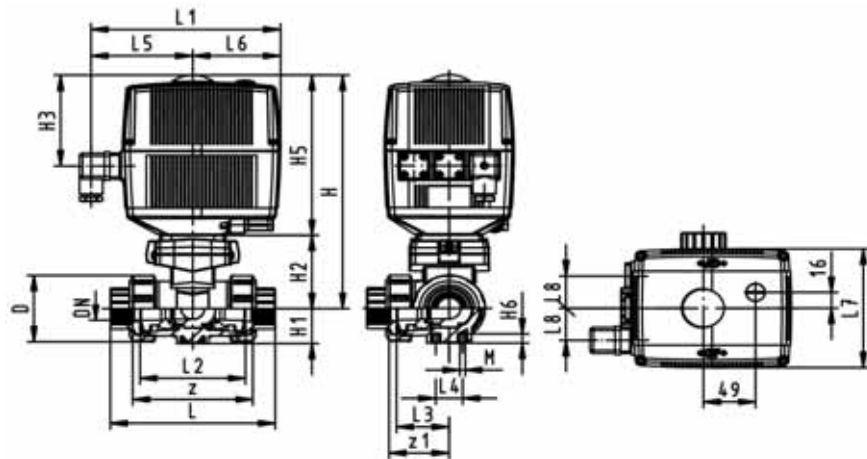



PROGEF Standard
3-Way ball valve type 186
Horizontal/L-port 100-230V
With manual emergency override
With socket fusion spigots metric

Model:

- Material: PP-H
- Built on with electric actuator EA21
- Voltage 100-230 V, 50-60 Hz
- Control range 90°<
- Basic position A-C opened, activated position B-C opened, see flow scheme
- Other positions possible by adjusting the limit switches
- Control time 5 s/90°<
- For easy installation and removal
- Integrated stainless steel mounting inserts

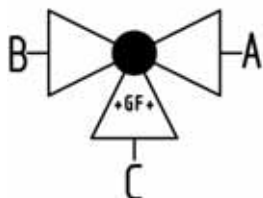

d [mm]	DN [mm]	PN	kv-value ($\Delta p=1$ bar) [l/min]	EPDM Code	FPM Code	kg
16	10	10	50	199 186 002	199 186 012	2.042
20	15	10	75	199 186 003	199 186 013	2.048
25	20	10	150	199 186 004	199 186 014	2.142
32	25	10	280	199 186 005	199 186 015	2.272
40	32	10	480	199 186 006	199 186 016	2.562
50	40	10	620	199 186 007	199 186 017	2.885
63	50	10	1230	199 186 008	199 186 018	3.833

d [mm]	D [mm]	H [mm]	H1 [mm]	H2 [mm]	H3 [mm]	H5 [mm]	H6 [mm]	L [mm]	L1 [mm]	L2 [mm]	L3 [mm]	L4 [mm]	L5 [mm]	L6 [mm]	L7 [mm]
16	50	231	28	64	94	167	8	126	180	72	36	25	97	83	122
20	50	231	28	64	94	167	8	136	180	72	36	25	97	83	122
25	58	240	32	73	94	167	8	159	180	85	43	25	97	83	122
32	68	240	36	73	94	167	8	178	180	98	49	25	97	83	122
40	84	251	45	84	94	167	9	204	180	118	59	45	97	83	122
50	97	251	51	84	94	167	9	237	180	135	68	45	97	83	122
63	124	273	65	106	94	167	9	296	180	176	88	45	97	83	122

d [mm]	L8 [mm]	M
16	33	6
20	33	6
25	33	6
32	33	6
40	33	8
50	33	8
63	33	8

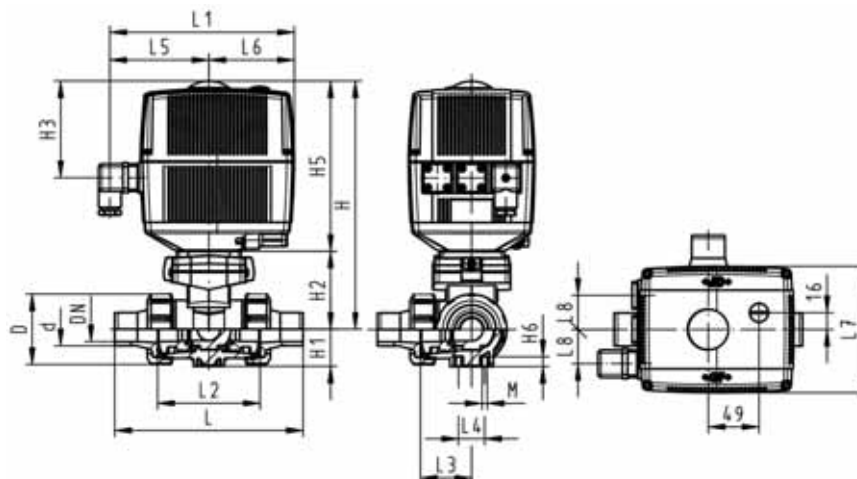



PROGEF Standard
3-Way ball valve type 186
Horizontal/L-port 100-230V
With manual emergency override
With butt fusion spigots
IR-Plus SDR11 metric

Model:

- Material: PP-H
- Built on with electric actuator EA21
- Voltage 100-230 V, 50-60 Hz
- Control range 90°(<)
- Basic position A-C opened, activated position B-C opened, see flow scheme
- Other positions possible by adjusting the limit switches
- Control time 5 s/90°(<)
- For easy installation and removal
- Integrated stainless steel mounting inserts

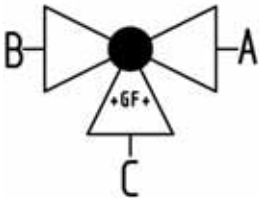

d [mm]	DN [mm]	PN	kv-value ($\Delta p=1$ bar) [l/min]	EPDM Code	FPM Code	kg
20	15	10	75	199 186 083	199 186 093	2.048
25	20	10	150	199 186 084	199 186 094	2.142
32	25	10	280	199 186 085	199 186 095	2.272
40	32	10	480	199 186 086	199 186 096	2.562
50	40	10	620	199 186 087	199 186 097	2.885
63	50	10	1230	199 186 088	199 186 098	3.833

d [mm]	D [mm]	H [mm]	H1 [mm]	H2 [mm]	H3 [mm]	H5 [mm]	H6 [mm]	L [mm]	L1 [mm]	L2 [mm]	L3 [mm]	L4 [mm]	L5 [mm]	L6 [mm]	L7 [mm]
20	50	231	28	64	94	167	8	146	180	72	36	25	97	83	122
25	58	240	32	73	94	167	8	163	180	85	43	25	97	83	122
32	68	240	36	73	94	167	8	178	180	98	49	25	97	83	122
40	84	251	45	84	94	167	9	204	180	118	59	45	97	83	122
50	97	251	51	84	94	167	9	237	180	135	68	45	97	83	122
63	124	273	65	106	94	167	9	296	180	176	88	45	97	83	122

d [mm]	L8 [mm]	M
20	33	6
25	33	6
32	33	6
40	33	8
50	33	8
63	33	8

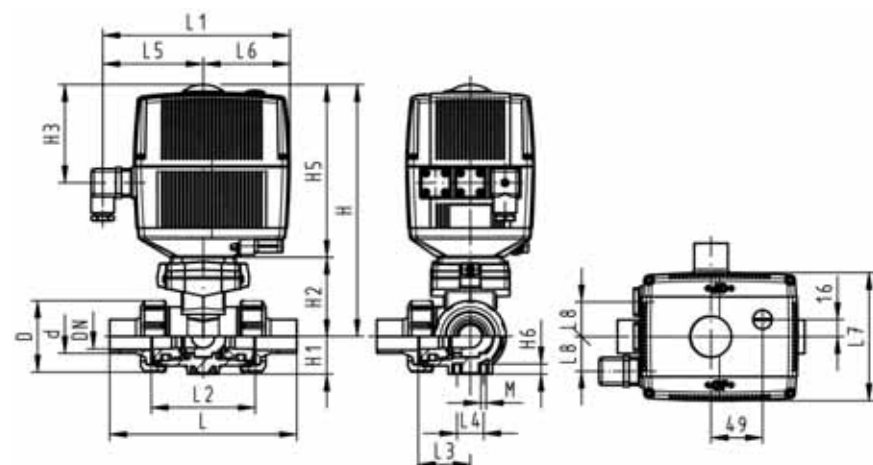



PROGEF Standard
3-Way ball valve type 186
Horizontal/L-port 24V
With manual emergency override
With fusion sockets metric

Model:

- Material: PP-H
- Built on with electric actuator EA21
- Voltage 24 V AC/DC
- Control range 90°<
- Basic position A-C opened, activated position B-C opened, see flow scheme
- Other positions possible by adjusting the limit switches
- Control time 5 s/90°<
- For easy installation and removal
- Integrated stainless steel mounting inserts

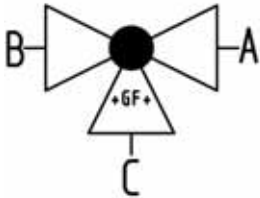

d [mm]	DN [mm]	PN	kv-value ($\Delta p=1$ bar) [l/min]	EPDM Code	FPM Code	kg
16	10	10	50	199 186 182	199 186 192	2.038
20	15	10	75	199 186 183	199 186 193	2.042
25	20	10	150	199 186 184	199 186 194	2.132
32	25	10	280	199 186 185	199 186 195	2.257
40	32	10	480	199 186 186	199 186 196	2.548
50	40	10	620	199 186 187	199 186 197	2.844
63	50	10	1230	199 186 188	199 186 198	3.751

d [mm]	D [mm]	H [mm]	H1 [mm]	H2 [mm]	H3 [mm]	H5 [mm]	H6 [mm]	L [mm]	L1 [mm]	L2 [mm]	L3 [mm]	L4 [mm]	L5 [mm]	L6 [mm]	L7 [mm]
16	50	231	28	64	94	167	8	110	180	72	36	25	97	83	122
20	50	231	28	64	94	167	8	112	180	72	36	25	97	83	122
25	58	240	32	73	94	167	8	129	180	85	43	25	97	83	122
32	68	240	36	73	94	167	8	146	180	98	49	25	97	83	122
40	84	251	45	84	94	167	9	170	180	118	59	45	97	83	122
50	97	251	51	84	94	167	9	193	180	135	68	45	97	83	122
63	124	273	65	106	94	167	9	244	180	176	88	45	97	83	122

d [mm]	L8 [mm]	M	z [mm]	z1 [mm]
16	33	6	82	41
20	33	6	82	41
25	33	6	97	49
32	33	6	110	55
40	33	8	132	66
50	33	8	151	76
63	33	8	188	94

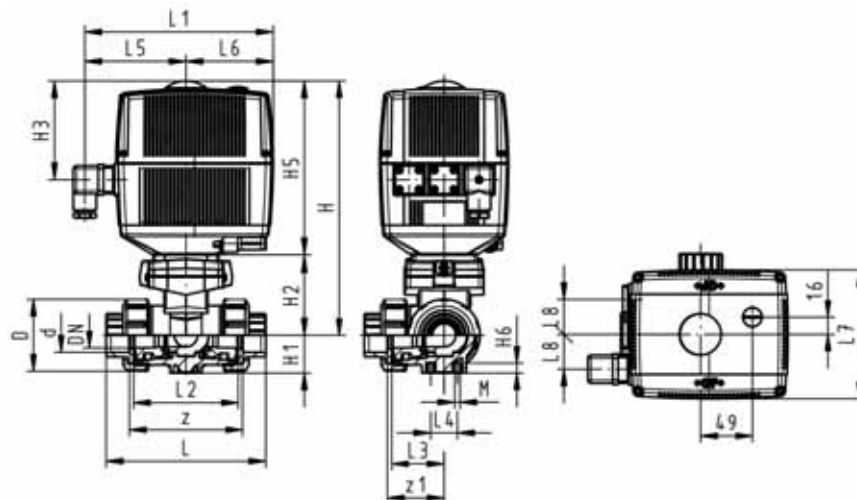



PROGEF Standard
3-Way ball valve type 186
Horizontal/L-port 24V
With manual emergency override
With threaded sockets reinforced Rp

Model:

- Material: PP-H
- Built on with electric actuator EA21
- Voltage 24 V AC/DC
- Control range 90°<
- Basic position A-C opened, activated position B-C opened, see flow scheme
- Other positions possible by adjusting the limit switches
- Control time 5 s/90°<
- For easy installation and removal
- Integrated stainless steel mounting inserts

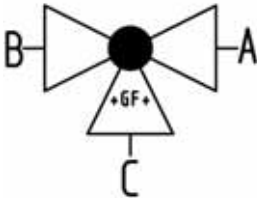

Rp [inch]	DN [mm]	PN	kv-value ($\Delta p=1$ bar) [l/min]	EPDM Code	FPM Code	kg
3/8	10	10	50	199 186 282	199 186 292	2.038
1/2	15	10	75	199 186 283	199 186 293	2.042
3/4	20	10	150	199 186 284	199 186 294	2.132
1	25	10	280	199 186 285	199 186 295	2.257
1 1/4	32	10	480	199 186 286	199 186 296	2.548
1 1/2	40	10	620	199 186 287	199 186 297	2.844
2	50	10	1230	199 186 288	199 186 298	3.751

Rp [inch]	D [mm]	H [mm]	H1 [mm]	H2 [mm]	H3 [mm]	H5 [mm]	H6 [mm]	L [mm]	L1 [mm]	L2 [mm]	L3 [mm]	L4 [mm]	L5 [mm]	L6 [mm]	L7 [mm]
3/8	50	231	28	64	94	167	8	112	180	72	36	25	97	83	122
1/2	50	231	28	64	94	167	8	114	180	72	36	25	97	83	122
3/4	58	240	32	73	94	167	8	131	180	85	43	25	97	83	122
1	68	240	36	73	94	167	8	154	180	98	49	25	97	83	122
1 1/4	84	251	45	84	94	167	9	180	180	118	59	45	97	83	122
1 1/2	97	251	51	84	94	167	9	203	180	135	68	45	97	83	122
2	124	273	65	106	94	167	9	258	180	176	88	45	97	83	122

Rp [inch]	L8 [mm]	M	z [mm]	z1 [mm]
3/8	33	6	86	43
1/2	33	6	84	42
3/4	33	6	99	50
1	33	6	112	56
1 1/4	33	8	132	66
1 1/2	33	8	153	77
2	33	8	196	98

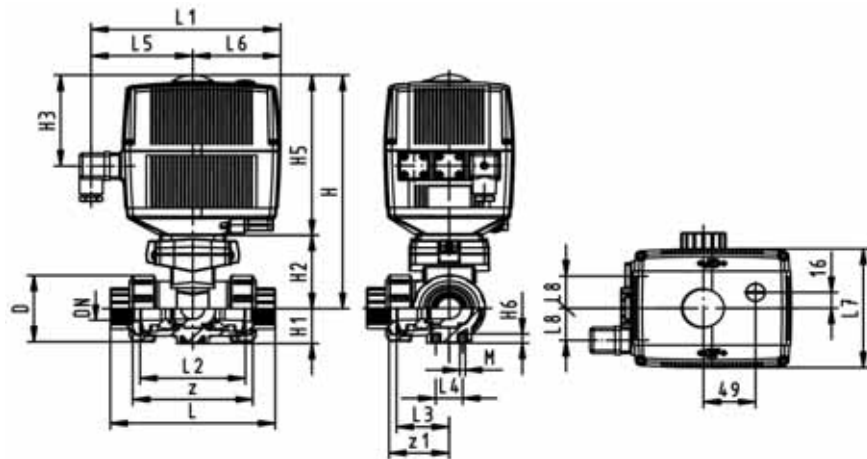



PROGEF Standard

3-Way ball valve type 186

Horizontal/L-port 24V

With manual emergency override

With socket fusion spigots metric

Model:

- Material: PP-H
- Built on with electric actuator EA21
- Voltage 24 V AC/DC
- Control range 90°<
- Basic position A-C opened, activated position B-C opened, see flow scheme
- Other positions possible by adjusting the limit switches
- Control time 5 s/90°<
- For easy installation and removal
- Integrated stainless steel mounting inserts

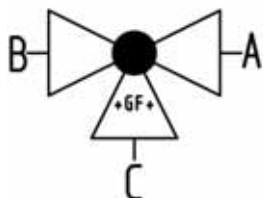

d [mm]	DN [mm]	PN	kv-value ($\Delta p=1$ bar) [l/min]	EPDM Code	FPM Code	kg
16	10	10	50	199 186 162	199 186 172	2.042
20	15	10	75	199 186 163	199 186 173	2.048
25	20	10	150	199 186 164	199 186 174	2.142
32	25	10	280	199 186 165	199 186 175	2.272
40	32	10	480	199 186 166	199 186 176	2.562
50	40	10	620	199 186 167	199 186 177	2.885
63	50	10	1230	199 186 168	199 186 178	3.833

d [mm]	D [mm]	H [mm]	H1 [mm]	H2 [mm]	H3 [mm]	H5 [mm]	H6 [mm]	L [mm]	L1 [mm]	L2 [mm]	L3 [mm]	L4 [mm]	L5 [mm]	L6 [mm]	L7 [mm]
16	50	231	28	64	94	167	8	126	180	72	36	25	97	83	122
20	50	231	28	64	94	167	8	136	180	72	36	25	97	83	122
25	58	240	32	73	94	167	8	159	180	85	43	25	97	83	122
32	68	240	36	73	94	167	8	178	180	98	49	25	97	83	122
40	84	251	45	84	94	167	9	204	180	118	59	45	97	83	122
50	97	251	51	84	94	167	9	237	180	135	68	45	97	83	122
63	124	273	65	106	94	167	9	296	180	176	88	45	97	83	122

d [mm]	L8 [mm]	M
16	33	6
20	33	6
25	33	6
32	33	6
40	33	8
50	33	8
63	33	8

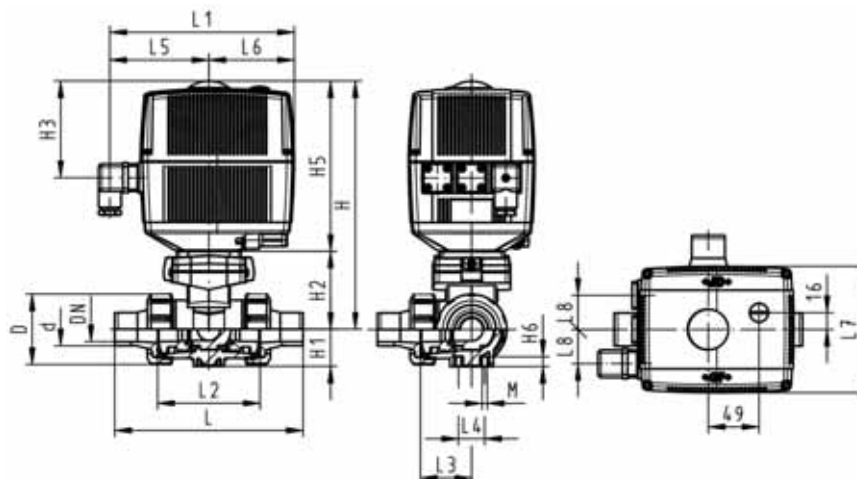



PROGEF Standard
3-Way ball valve type 186
Horizontal/L-port 24V
With manual emergency override
With butt fusion spigots
IR-Plus SDR11 metric

Model:

- Material: PP-H
- Built on with electric actuator EA21
- Voltage 24 V AC/DC
- Control range 90°<
- Basic position A-C opened, activated position B-C opened, see flow scheme
- Other positions possible by adjusting the limit switches
- Control time 5 s/90°<
- For easy installation and removal
- Integrated stainless steel mounting inserts

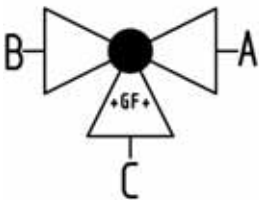

d [mm]	DN [mm]	PN	kv-value ($\Delta p=1$ bar) [l/min]	EPDM Code	FPM Code	kg
20	15	10	75	199 186 243	199 186 253	2.048
25	20	10	150	199 186 244	199 186 254	2.142
32	25	10	280	199 186 245	199 186 255	2.272
40	32	10	480	199 186 246	199 186 256	2.562
50	40	10	620	199 186 247	199 186 257	2.885
63	50	10	1230	199 186 248	199 186 258	3.833

d [mm]	D [mm]	H [mm]	H1 [mm]	H2 [mm]	H3 [mm]	H5 [mm]	H6 [mm]	L [mm]	L1 [mm]	L2 [mm]	L3 [mm]	L4 [mm]	L5 [mm]	L6 [mm]	L7 [mm]
20	50	231	28	64	94	167	8	146	180	72	36	25	97	83	122
25	58	240	32	73	94	167	8	163	180	85	43	25	97	83	122
32	68	240	36	73	94	167	8	178	180	98	49	25	97	83	122
40	84	251	45	84	94	167	9	204	180	118	59	45	97	83	122
50	97	251	51	84	94	167	9	237	180	135	68	45	97	83	122
63	124	273	65	106	94	167	9	296	180	176	88	45	97	83	122

d [mm]	L8 [mm]	M
20	33	6
25	33	6
32	33	6
40	33	8
50	33	8
63	33	8

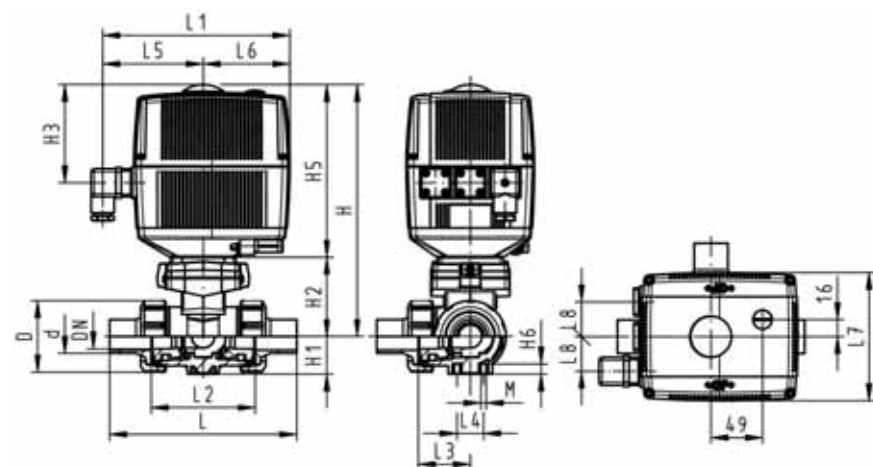



PROGEF Standard
3-Way ball valve type 186
Horizontal/T-port 100-230V
With manual emergency override
With fusion sockets metric

Model:

- Material: PP-H
- Built on with electric actuator EA21
- Voltage 100-230 V, 50-60 Hz
- Control range 90°<
- Basic position A-B-C opened, activated position B-C opened, see flow scheme
- Other positions possible by adjusting the limit switches
- Control time 5 s/90°<
- For easy installation and removal
- Integrated stainless steel mounting inserts

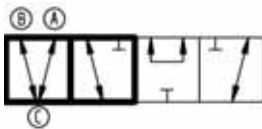
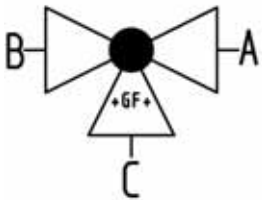

d [mm]	DN [mm]	PN	kv-value ($\Delta p=1$ bar) [l/min]	EPDM Code	FPM Code	kg
16	10	10	140	199 186 062	199 186 072	2.038
20	15	10	200	199 186 063	199 186 073	2.481
25	20	10	470	199 186 064	199 186 074	2.131
32	25	10	793	199 186 065	199 186 075	2.252
40	32	10	1290	199 186 066	199 186 076	2.541
50	40	10	1910	199 186 067	199 186 077	2.830
63	50	10	3100	199 186 068	199 186 078	3.722

d [mm]	D [mm]	H [mm]	H1 [mm]	H2 [mm]	H3 [mm]	H5 [mm]	H6 [mm]	L [mm]	L1 [mm]	L2 [mm]	L3 [mm]	L4 [mm]	L5 [mm]	L6 [mm]	L7 [mm]
16	50	231	28	64	94	167	8	110	180	72	36	25	97	83	122
20	50	231	28	64	94	167	8	112	180	72	36	25	97	83	122
25	58	240	32	73	94	167	8	129	180	85	43	25	97	83	122
32	68	240	36	73	94	167	8	146	180	98	49	25	97	83	122
40	84	251	45	84	94	167	9	170	180	118	59	45	97	83	122
50	97	251	51	84	94	167	9	193	180	135	68	45	97	83	122
63	124	273	65	106	94	167	9	244	180	176	88	45	97	83	122

d [mm]	L8 [mm]	M	z [mm]	z1 [mm]
16	33	6	82	41
20	33	6	82	41
25	33	6	97	49
32	33	6	110	55
40	33	8	132	66
50	33	8	151	76
63	33	8	188	94

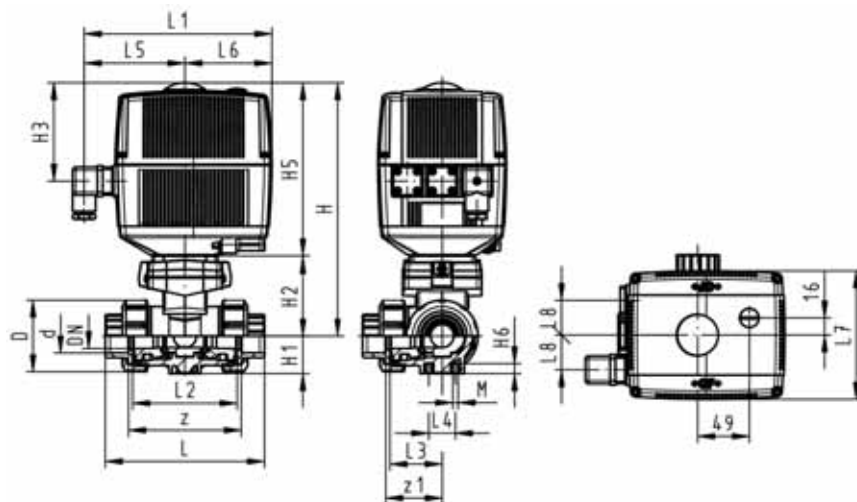



PROGEF Standard
3-Way ball valve type 186
Horizontal/T-port 100-230V
With manual emergency override
With threaded sockets reinforced Rp

Model:

- Material: PP-H
- Built on with electric actuator EA21
- Voltage 100-230 V, 50-60 Hz
- Control range 90°<
- Basic position A-B-C opened, activated position B-C opened, see flow scheme
- Other positions possible by adjusting the limit switches
- Control time 5 s/90°<
- For easy installation and removal
- Integrated stainless steel mounting inserts

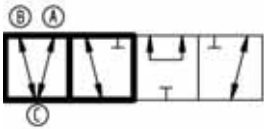
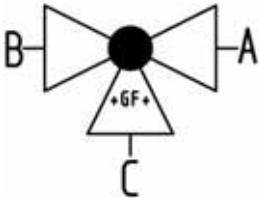

Rp [inch]	DN [mm]	PN	kv-value ($\Delta p=1$ bar) [l/min]	EPDM Code	FPM Code	kg
3/8	10	10	140	199 186 142	199 186 152	2.038
1/2	15	10	200	199 186 143	199 186 153	2.042
3/4	20	10	470	199 186 144	199 186 154	2.131
1	25	10	793	199 186 145	199 186 155	2.252
1 1/4	32	10	1290	199 186 146	199 186 156	2.541
1 1/2	40	10	1910	199 186 147	199 186 157	2.830
2	50	10	3100	199 186 148	199 186 158	3.722

Rp [inch]	D [mm]	H [mm]	H1 [mm]	H2 [mm]	H3 [mm]	H5 [mm]	H6 [mm]	L [mm]	L1 [mm]	L2 [mm]	L3 [mm]	L4 [mm]	L5 [mm]	L6 [mm]	L7 [mm]
3/8	50	231	28	64	94	167	8	112	180	72	36	25	97	83	122
1/2	50	231	28	64	94	167	8	114	180	72	36	25	97	83	122
3/4	58	240	32	73	94	167	8	131	180	85	43	25	97	83	122
1	68	240	36	73	94	167	8	154	180	98	49	25	97	83	122
1 1/4	84	251	45	84	94	167	9	180	180	118	59	45	97	83	122
1 1/2	97	251	51	84	94	167	9	203	180	135	68	45	97	83	122
2	124	273	65	106	94	167	9	258	180	176	88	45	97	83	122

Rp [inch]	L8 [mm]	M	z [mm]	z1 [mm]
3/8	33	6	86	43
1/2	33	6	84	42
3/4	33	6	99	50
1	33	6	112	56
1 1/4	33	8	132	66
1 1/2	33	8	153	77
2	33	8	196	98

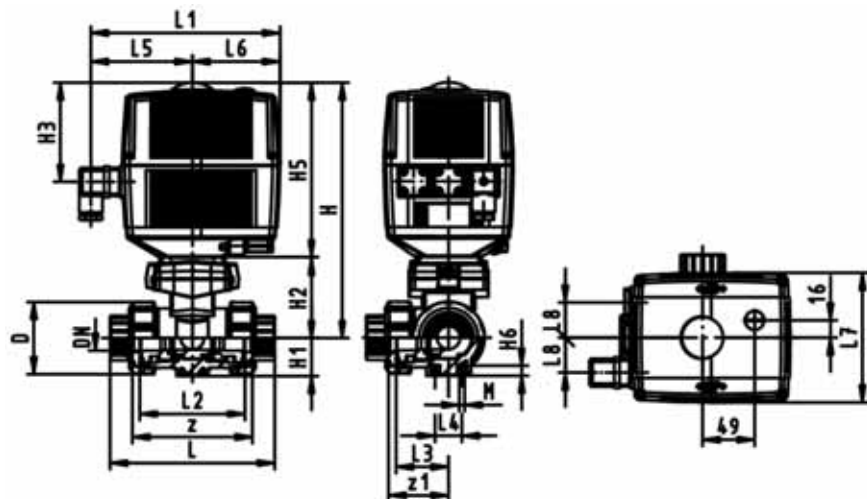



PROGEF Standard
3-Way ball valve type 186
Horizontal/T-port 100-230V
With manual emergency override
With socket fusion spigots metric

Model:

- Material: PP-H
- Built on with electric actuator EA21
- Voltage 100-230 V, 50-60 Hz
- Control range 90°<
- Basic position A-B-C opened, activated position B-C opened, see flow scheme
- Other positions possible by adjusting the limit switches
- Control time 5 s/90°<
- For easy installation and removal
- Integrated stainless steel mounting inserts

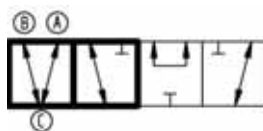
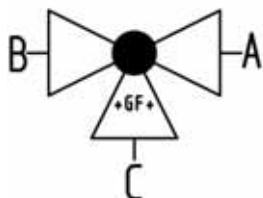

d [mm]	DN [mm]	PN	kv-value ($\Delta p=1$ bar) [l/min]	EPDM Code	FPM Code	kg
16	10	10	140	199 186 042	199 186 052	2.042
20	15	10	200	199 186 043	199 186 053	2.048
25	20	10	470	199 186 044	199 186 054	2.141
32	25	10	793	199 186 045	199 186 055	2.268
40	32	10	1290	199 186 046	199 186 056	2.555
50	40	10	1910	199 186 047	199 186 057	2.872
63	50	10	3100	199 186 048	199 186 058	3.804

d [mm]	D [mm]	H [mm]	H1 [mm]	H2 [mm]	H3 [mm]	H5 [mm]	H6 [mm]	L [mm]	L1 [mm]	L2 [mm]	L3 [mm]	L4 [mm]	L5 [mm]	L6 [mm]	L7 [mm]
16	50	231	28	64	94	167	8	126	180	72	36	25	97	83	122
20	50	231	28	64	94	167	8	136	180	72	36	25	97	83	122
25	58	240	32	73	94	167	8	159	180	85	43	25	97	83	122
32	68	240	36	73	94	167	8	178	180	98	49	25	97	83	122
40	84	251	45	84	94	167	9	204	180	118	59	45	97	83	122
50	97	251	51	84	94	167	9	237	180	135	68	45	97	83	122
63	124	273	65	106	94	167	9	296	180	176	88	45	97	83	122

d [mm]	L8 [mm]	M
16	33	6
20	33	6
25	33	6
32	33	6
40	33	8
50	33	8
63	33	8

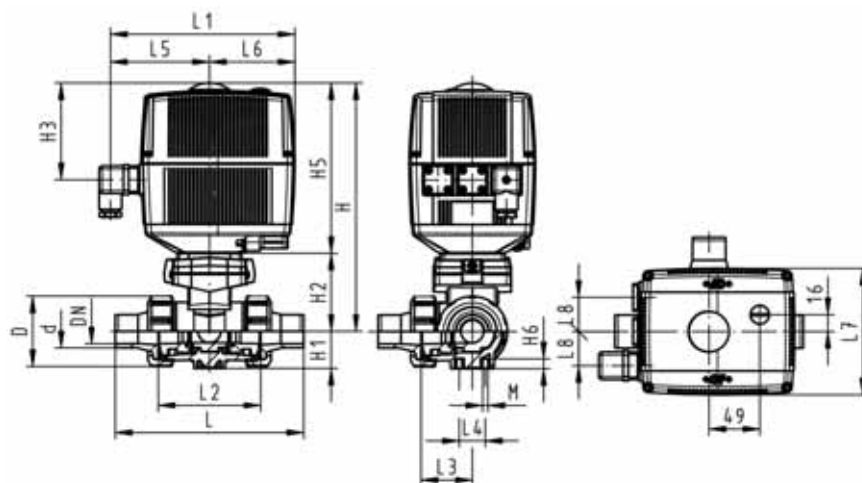



PROGEF Standard
3-Way ball valve type 186
Horizontal/T-port 100-230V
With manual emergency override
With butt fusion spigots
IR-Plus SDR11 metric

Model:

- Material: PP-H
- Built on with electric actuator EA21
- Voltage 100-230 V, 50-60 Hz
- Control range 90°<
- Basic position A-B-C opened, activated position B-C opened, see flow scheme
- Other positions possible by adjusting the limit switches
- Control time 5 s/90°<
- For easy installation and removal
- Integrated stainless steel mounting inserts

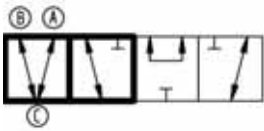
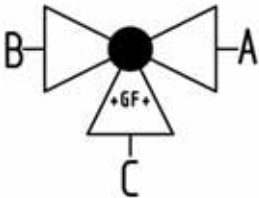

d [mm]	DN [mm]	PN	kv-value ($\Delta p=1$ bar) [l/min]	EPDM Code	FPM Code	kg
20	15	10	200	199 186 103	199 186 113	2.048
25	20	10	470	199 186 104	199 186 114	2.141
32	25	10	793	199 186 105	199 186 115	2.268
40	32	10	1290	199 186 106	199 186 116	2.555
50	40	10	1910	199 186 107	199 186 117	2.872
63	50	10	3100	199 186 108	199 186 118	3.804

d [mm]	D [mm]	H [mm]	H1 [mm]	H2 [mm]	H3 [mm]	H5 [mm]	H6 [mm]	L [mm]	L1 [mm]	L2 [mm]	L3 [mm]	L4 [mm]	L5 [mm]	L6 [mm]	L7 [mm]
20	50	231	28	64	94	167	8	146	180	72	36	25	97	83	122
25	58	240	32	73	94	167	8	163	180	85	43	25	97	83	122
32	68	240	36	73	94	167	8	178	180	98	49	25	97	83	122
40	84	251	45	84	94	167	9	204	180	118	59	45	97	83	122
50	97	251	51	84	94	167	9	237	180	135	68	45	97	83	122
63	124	273	65	106	94	167	9	296	180	176	88	45	97	83	122

d [mm]	L8 [mm]	M
20	33	6
25	33	6
32	33	6
40	33	8
50	33	8
63	33	8

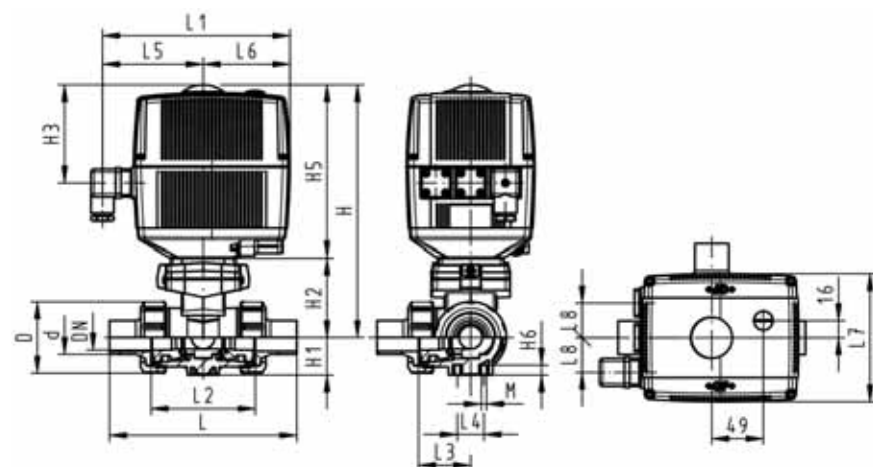



PROGEF Standard

3-Way ball valve type 186

Horizontal/T-port 24V

With manual emergency override

With fusion sockets metric

Model:

- Material: PP-H
- Built on with electric actuator EA21
- Voltage 24 V AC/DC
- Control range 90°<
- Basic position A-B-C opened, activated position B-C opened, see flow scheme
- Other positions possible by adjusting the limit switches
- Control time 5 s/90°<
- For easy installation and removal
- Integrated stainless steel mounting inserts

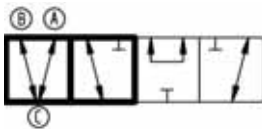
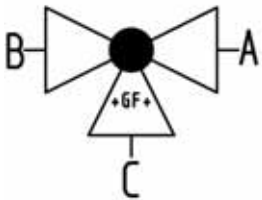

d [mm]	DN [mm]	PN	kv-value ($\Delta p=1$ bar) [l/min]	EPDM Code	FPM Code	kg
16	10	10	140	199 186 222	199 186 232	2.038
20	15	10	200	199 186 223	199 186 233	2.042
25	20	10	470	199 186 224	199 186 234	2.131
32	25	10	793	199 186 225	199 186 235	2.252
40	32	10	1290	199 186 226	199 186 236	2.541
50	40	10	1910	199 186 227	199 186 237	2.830
63	50	10	3100	199 186 228	199 186 238	3.722

d [mm]	D [mm]	H [mm]	H1 [mm]	H2 [mm]	H3 [mm]	H5 [mm]	H6 [mm]	L [mm]	L1 [mm]	L2 [mm]	L3 [mm]	L4 [mm]	L5 [mm]	L6 [mm]	L7 [mm]
16	50	231	28	64	94	167	8	110	180	72	36	25	97	83	122
20	50	231	28	64	94	167	8	112	180	72	36	25	97	83	122
25	58	240	32	73	94	167	8	129	180	85	43	25	97	83	122
32	68	240	36	73	94	167	8	146	180	98	49	25	97	83	122
40	84	251	45	84	94	167	9	170	180	118	59	45	97	83	122
50	97	251	51	84	94	167	9	193	180	135	68	45	97	83	122
63	124	273	65	106	94	167	9	244	180	176	88	45	97	83	122

d [mm]	L8 [mm]	M	z [mm]	z1 [mm]
16	33	6	82	41
20	33	6	82	41
25	33	6	97	49
32	33	6	110	55
40	33	8	132	66
50	33	8	151	76
63	33	8	188	94

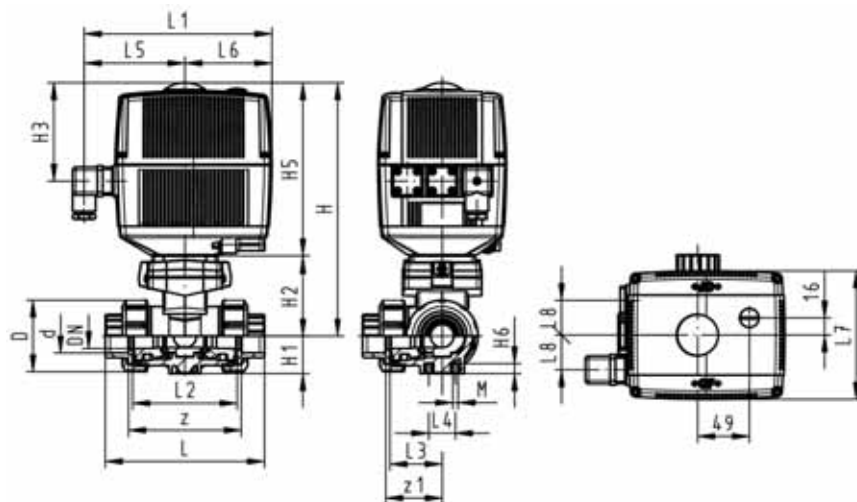



PROGEF Standard
3-Way ball valve type 186
Horizontal/T-port 24V
With manual emergency override
With threaded sockets reinforced Rp

Model:

- Material: PP-H
- Built on with electric actuator EA21
- Voltage 24 V AC/DC
- Control range 90°<
- Basic position A-B-C opened, activated position B-C opened, see flow scheme
- Other positions possible by adjusting the limit switches
- Control time 5 s/90°<
- For easy installation and removal
- Integrated stainless steel mounting inserts

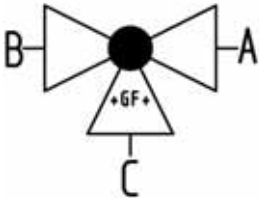

Rp [inch]	DN [mm]	PN	kv-value (Δp=1 bar) [l/min]	EPDM Code	FPM Code	kg
3/8	10	10	140	199 186 302	199 186 312	2.038
1/2	15	10	200	199 186 303	199 186 313	2.042
3/4	20	10	470	199 186 304	199 186 314	2.131
1	25	10	793	199 186 305	199 186 315	2.252
1 1/4	32	10	1290	199 186 306	199 186 316	2.541
1 1/2	40	10	1910	199 186 307	199 186 317	2.830
2	50	10	3100	199 186 308	199 186 318	3.722

Rp [inch]	D [mm]	H [mm]	H1 [mm]	H2 [mm]	H3 [mm]	H5 [mm]	H6 [mm]	L [mm]	L1 [mm]	L2 [mm]	L3 [mm]	L4 [mm]	L5 [mm]	L6 [mm]	L7 [mm]
3/8	50	231	28	64	94	167	8	112	180	72	36	25	97	83	122
1/2	50	231	28	64	94	167	8	114	180	72	36	25	97	83	122
3/4	58	240	32	73	94	167	8	131	180	85	43	25	97	83	122
1	68	240	36	73	94	167	8	154	180	98	49	25	97	83	122
1 1/4	84	251	45	84	94	167	9	180	180	118	59	45	97	83	122
1 1/2	97	251	51	84	94	167	9	203	180	135	68	45	97	83	122
2	124	273	65	106	94	167	9	258	180	176	88	45	97	83	122

Rp [inch]	L8 [mm]	M	z [mm]	z1 [mm]
3/8	33	6	86	43
1/2	33	6	84	42
3/4	33	6	99	50
1	33	6	112	56
1 1/4	33	8	132	66
1 1/2	33	8	153	77
2	33	8	196	98

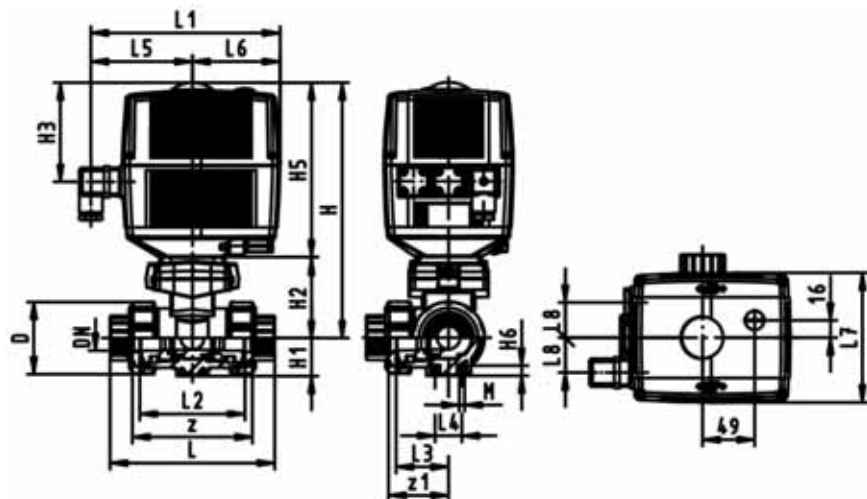



PROGEF Standard

3-Way ball valve type 186

Horizontal/T-port 24V

With manual emergency override

With socket fusion spigots metric

Model:

- Material: PP-H
- Built on with electric actuator EA21
- Voltage 24 V AC/DC
- Control range 90°<
- Basic position A-B-C opened, activated position B-C opened, see flow scheme
- Other positions possible by adjusting the limit switches
- Control time 5 s/90°<
- For easy installation and removal
- Integrated stainless steel mounting inserts

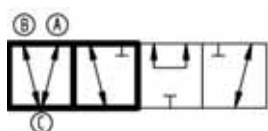
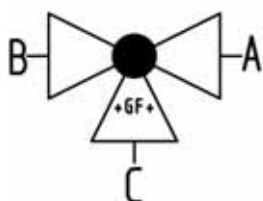

d [mm]	DN [mm]	PN	kv-value ($\Delta p=1$ bar) [l/min]	EPDM Code	FPM Code	kg
16	10	10	140	199 186 202	199 186 212	2.042
20	15	10	200	199 186 203	199 186 213	2.048
25	20	10	470	199 186 204	199 186 214	2.141
32	25	10	793	199 186 205	199 186 215	2.268
40	32	10	1290	199 186 206	199 186 216	2.555
50	40	10	1910	199 186 207	199 186 217	2.872
63	50	10	3100	199 186 208	199 186 218	3.804

d [mm]	D [mm]	H [mm]	H1 [mm]	H2 [mm]	H3 [mm]	H5 [mm]	H6 [mm]	L [mm]	L1 [mm]	L2 [mm]	L3 [mm]	L4 [mm]	L5 [mm]	L6 [mm]	L7 [mm]
16	50	231	28	64	94	167	8	126	180	72	36	25	97	83	122
20	50	231	28	64	94	167	8	136	180	72	36	25	97	83	122
25	58	240	32	73	94	167	8	159	180	85	43	25	97	83	122
32	68	240	36	73	94	167	8	178	180	98	49	25	97	83	122
40	84	251	45	84	94	167	9	204	180	118	59	45	97	83	122
50	97	251	51	84	94	167	9	237	180	135	68	45	97	83	122
63	124	273	65	106	94	167	9	296	180	176	88	45	97	83	122

d [mm]	L8 [mm]	M
16	33	6
20	33	6
25	33	6
32	33	6
40	33	8
50	33	8
63	33	8

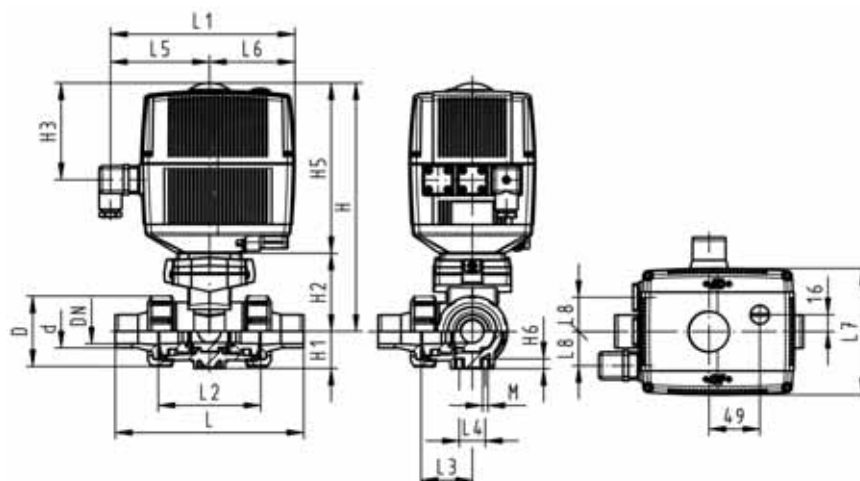



PROGEF Standard
3-Way ball valve type 186
Horizontal/T-port 24V
With manual emergency override
With butt fusion spigots
IR-Plus SDR11 metric

Model:

- Material: PP-H
- Built on with electric actuator EA21
- Voltage 24 V AC/DC
- Control range 90°<
- Basic position A-B-C opened, activated position B-C opened, see flow scheme
- Other positions possible by adjusting the limit switches
- Control time 5 s/90°<
- For easy installation and removal
- Integrated stainless steel mounting inserts

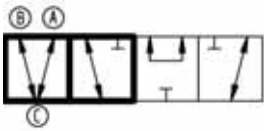
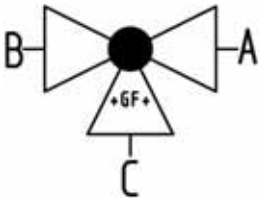

d [mm]	DN [mm]	PN	kv-value ($\Delta p=1$ bar) [l/min]	EPDM Code	FPM Code	kg
20	15	10	200	199 186 263	199 186 273	2.048
25	20	10	470	199 186 264	199 186 274	2.141
32	25	10	793	199 186 265	199 186 275	2.268
40	32	10	1290	199 186 266	199 186 276	2.555
50	40	10	1910	199 186 267	199 186 277	2.872
63	50	10	3100	199 186 268	199 186 278	3.804

d [mm]	D [mm]	H [mm]	H1 [mm]	H2 [mm]	H3 [mm]	H5 [mm]	H6 [mm]	L [mm]	L1 [mm]	L2 [mm]	L3 [mm]	L4 [mm]	L5 [mm]	L6 [mm]	L7 [mm]
20	50	231	28	64	94	167	8	146	180	72	36	25	97	83	122
25	58	240	32	73	94	167	8	163	180	85	43	25	97	83	122
32	68	240	36	73	94	167	8	178	180	98	49	25	97	83	122
40	84	251	45	84	94	167	9	204	180	118	59	45	97	83	122
50	97	251	51	84	94	167	9	237	180	135	68	45	97	83	122
63	124	273	65	106	94	167	9	296	180	176	88	45	97	83	122

d [mm]	L8 [mm]	M
20	33	6
25	33	6
32	33	6
40	33	8
50	33	8
63	33	8

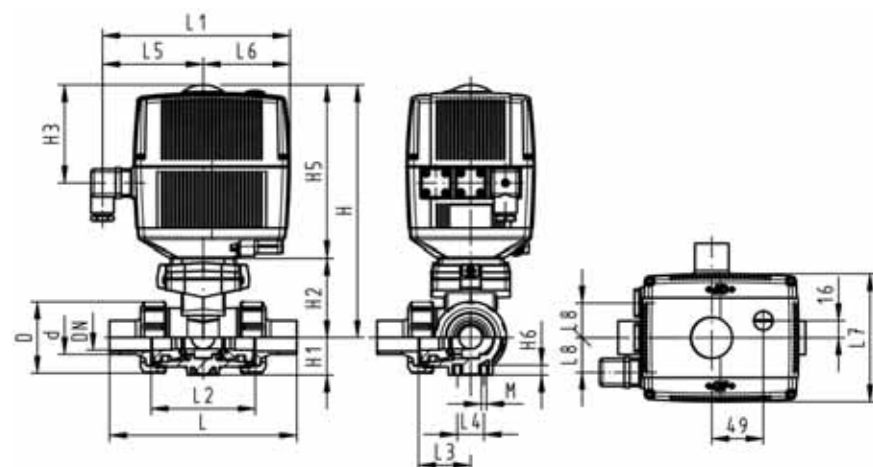

Copiable

Configurator GF ball valve type 546 PROGEF Standard

Ball Valve

- A01 Ball Valve 546
- A02 Linear Ball Valve

Material

- B05 PP-H

Dimension

- C05 d 16 DN 10 3/8"
- C06 d 20 DN 15 1/2"
- C07 d 25 DN 20 3/4"
- C08 d 32 DN 25 1"
- C09 d 40 DN 32 1 1/4"
- C10 d 50 DN 40 1 1/2"
- C11 d 63 DN 50 2"
- C12 DN 65 2 1/2"
- C13 DN 80 3"
- C14 DN 100 4"
- C15 DN 150 6"

Version

- D01 Standard, PTFE ball seal
- D02 oilfree, PTFE ball seal (only with specific connecting parts)
- D03 silicon-free, PTFE ball seal (only with specific connecting parts)
- D04 silicon-free, PVDF ball seal for metric (only with specific connecting parts)

Seals

- E01 EPDM seals
- E02 FPM seals
- E03 FFPM/KALREZ® seals

Threaded inserts

- F01 without threaded inserts
- F02 with threaded inserts

Connecting parts

- G30 PP-H Fusion socket metric
- G32 PP-H Socket fusion spigot metric
- G33 PP-H Threaded socket Rp reinforced
- G34 PP-H Threaded socket NPT reinforced
- G35 PP-H Butt fusion spigot SDR 11 metric IR-PLUS®
- G36 PP-H Butt fusion spigot SDR 17.6 metric
with this valve end the maximum nominal pressure is reduced to PN 6
- G37 PP-H Butt fusion spigot long SDR11 metric
- G43 PE-100 Butt fusion spigot long SDR11 metric
- G44 PE-100 Butt fusion spigot long SDR17.6 metric
- G63 Fixed flange PP-H serrated metric
- G72 Backing flange PP-steel metric
- G73 Backing flange PP-steel inch ANSI
- G77 Backing flange PP JIS with connecting parts
- G78 Backing flange PP-GF JIS
- G83 PP-H Valve end blank
- G40 PE-100 Fusion socket metric
- G41 PE-100 Butt fusion spigot SDR11 metric
- G42 PE-100 Butt fusion spigot SDR17.6 metric
- G43 PE-100 Butt fusion spigot long SDR11 metric
- G11 PVC-C Cement socket metric
- G13 PVC-C Cement socket inch ASTM
- G14 PVC-C Cement spigot metric
- G15 PVC-C Threaded socket Rp
- G16 PVC-C Threaded socket Rp reinforced
- G17 PVC-C Threaded socket NPT

Multi-functional module

- I01 No multi-functional module
- I02 Empty module
- I03 Module with 2 end switches Ag, Ni
- I04 Module with 2 end switches Au
- I05 Module with 2 inductive switches Namur
- I06 Module with 2 inductive switches PNP
- I07 Module with 2 inductive switches NPN

Lever

- K01 Standard lever red
- K02 Standard lever black
- K11 Multi-functional lever red

Mounting plate

- L01 without mounting plate
- L02 with mounting plate

A01 B05 C D E F G G I K L

left right

You will find a large selection of different versions in our range of products. New system elements also provide you with new opportunities for use. In order for us to supply exactly the ball valve you need for your application, we have created a selection menu for you. (Der maximal zulässige Betriebsdruck des Kugelhahns ist PN 10).

We supply what you put together.

Copiable GF ball valve type 546 with pneumatic actuator

It's so easy to configure the type 546:

With the configurator, you have a choice of new pneumatic actuators PA11 and PA21 in 2 optimized sizes including a large range of accessories.

We supply what you put together.

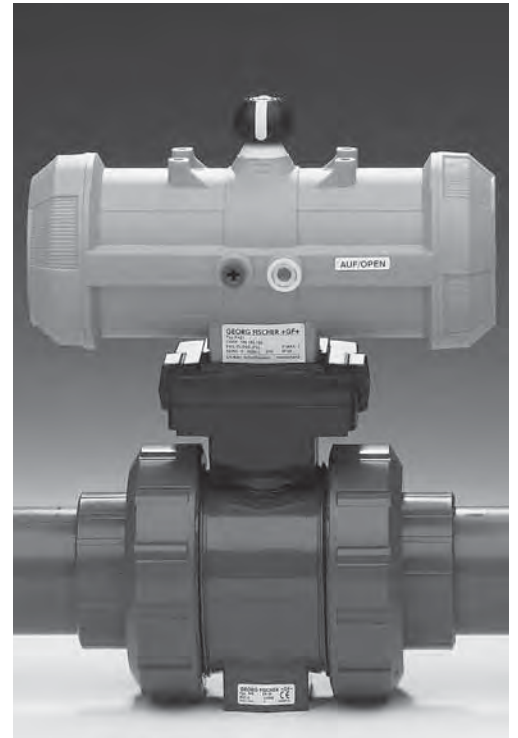

Pneumatic actuators PA11/PA21

- P01 Fail safe to close PA11/PA21
- P02 Fail safe to open PA11/21
- P03 Double acting PA11/21
- P30 Fail safe to close PA30/90
- P31 Fail safe to open PA30/90
- P32 Double acting PA30/90

Manual override

- Q01 without manual override
- Q02 with manual override

Stroke limiter

- R01 without stroke limiter
- R02 with stroke limiter

P	Q	R	
----------	----------	----------	--

Ball Valves Pneumatic

PROGEF Standard

Ball valve type 231 FC (Fail safe to close)

With manual override

With fusion sockets metric



DN10/15 - 50

Model:

- Material: PP-H
- Built on with pneumatic actuator PA11 (DN10/15-25), PA21 (DN32-50)
- Control time $90^\circ <$ 1-2 s
- For easy installation and removal
- Integrated stainless steel mounting inserts

Option:

- Individual configuration of the valve (see diagram)

d [mm]	DN [mm]	PN	kv-value ($\Delta p=1$ bar) [l/min]	EPDM Code	FPM Code	kg
16	10	10	70	199 231 002	199 231 012	1.500
20	15	10	185	199 231 003	199 231 013	1.500
25	20	10	350	199 231 004	199 231 014	1.600
32	25	10	700	199 231 005	199 231 015	1.700
40	32	10	1000	199 231 006	199 231 016	2.800
50	40	10	1600	199 231 007	199 231 017	3.100
63	50	10	3100	199 231 008	199 231 018	2.985

d [mm]	D [mm]	H [mm]	H1 [mm]	H2 [mm]	H3 [mm]	H4 [mm]	H5 [mm]	L [mm]	L1 [mm]	L2 [mm]	L4 [mm]	L5 [mm]	L6 [mm]	L7 [mm]	z [mm]
16	50	230	27	62	168	40	77	93	194	56	25	261	76	48	67
20	50	230	27	62	168	40	77	95	194	56	25	261	76	48	66
25	58	239	30	71	168	40	77	108	194	65	25	261	76	48	77
32	68	239	36	71	168	40	77	118	194	71	25	261	76	48	83
40	84	271	44	84	187	51	99	137	224	85	45	305	95	59	99
50	97	271	51	84	187	51	99	147	224	89	45	305	95	59	105
63	124	293	64	106	187	51	99	168	224	101	45	305	95	59	117

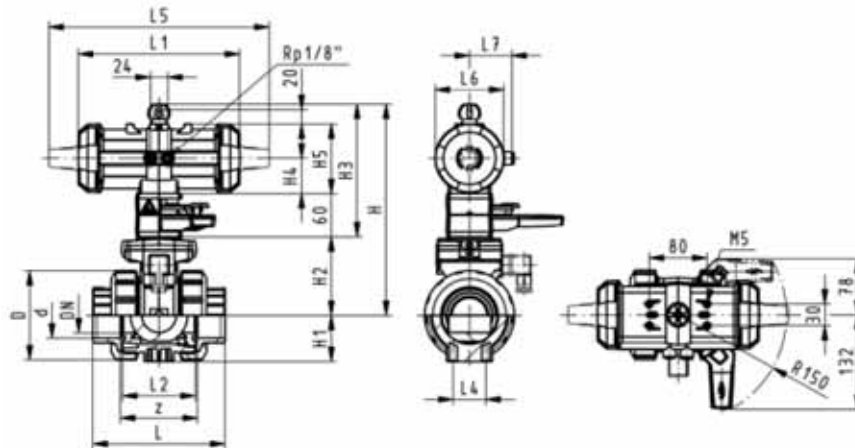



PROGEF Standard Ball valve type 231 FC (Fail safe to close) With manual override With socket fusion spigots metric

Model:

- Material: PP-H
- Built on with pneumatic actuator PA11 (DN10/15-25), PA21 (DN32-50)
- Control time 90°< 1-2 s
- For easy installation and removal
- Integrated stainless steel mounting inserts

Option:

- Individual configuration of the valve (see diagram)

d [mm]	DN [mm]	PN	kv-value ($\Delta p=1$ bar) [l/min]	EPDM Code	FPM Code	kg
16	10	10	70	199 231 022	199 231 032	1.500
20	15	10	185	199 231 023	199 231 033	1.500
25	20	10	350	199 231 024	199 231 034	1.600
32	25	10	700	199 231 025	199 231 035	1.700
40	32	10	1000	199 231 026	199 231 036	2.800
50	40	10	1600	199 231 027	199 231 037	3.100
63	50	10	3100	199 231 028	199 231 038	3.051

d [mm]	D [mm]	H [mm]	H1 [mm]	H2 [mm]	H3 [mm]	H4 [mm]	H5 [mm]	L [mm]	L1 [mm]	L2 [mm]	L3 [mm]	L4 [mm]	L5 [mm]	L6 [mm]	L7 [mm]
16	50	159	27	62	168	40	77	110	194	56		25	261	76	48
20	50	159	27	62	168	40	77	120	194	56	130	25	261	76	48
25	58	168	30	71	168	40	77	139	194	65	150	25	261	76	48
32	68	168	36	71	168	40	77	150	194	71	160	25	261	76	48
40	84	202	44	84	187	51	99	170	224	85	180	45	305	95	59
50	97	202	51	84	187	51	99	190	224	89	200	45	305	95	59
63	124	225	64	106	187	51	99	220	224	101	230	45	305	95	59

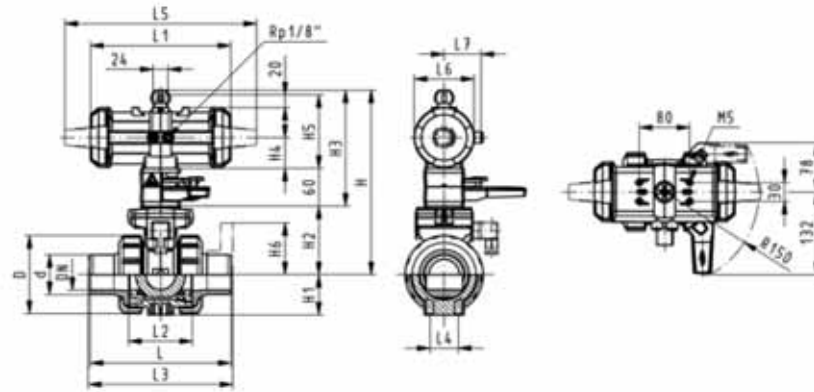



PROGEF Standard
Ball valve type 231 FC (Fail safe to close)
With manual override
With butt fusion spigots IR-Plus SDR11 metric

Model:

- Material: PP-H
- Built on with pneumatic actuator PA11 (DN10/15-25), PA21 (DN32-50)
- Control time 90°< 1-2 s
- For easy installation and removal
- Integrated stainless steel mounting inserts

Option:

- Individual configuration of the valve (see diagram)

d [mm]	DN [mm]	PN	kv-value ($\Delta p=1$ bar) [l/min]	EPDM Code	FPM Code	kg
20	15	10	185	199 231 623	199 231 633	1.500
25	20	10	350	199 231 624	199 231 634	1.600
32	25	10	700	199 231 625	199 231 635	1.387
40	32	10	1000	199 231 626	199 231 636	2.800
50	40	10	1600	199 231 627	199 231 637	3.100
63	50	10	3100	199 231 628	199 231 638	4.000

d [mm]	D [mm]	H [mm]	H1 [mm]	H2 [mm]	H3 [mm]	H4 [mm]	H5 [mm]	L [mm]	L1 [mm]	L2 [mm]	L3 [mm]	L4 [mm]	L5 [mm]	L6 [mm]	L7 [mm]
20	50	159	27	62	168	40	77	130	194	56		25	261	76	48
25	50	159	27	62	168	40	77	143	194	56	130	25	261	76	48
32	58	168	30	71	168	40	77	150	194	65	150	25	261	76	48
40	68	168	36	71	168	40	77	171	194	71	160	25	261	76	48
50	84	202	44	84	187	51	99	191	224	85	180	45	305	95	59
63	97	202	51	84	187	51	99	220	224	89	200	45	305	95	59

d [mm]	e [mm]
20	1.9
25	2.3
32	3.0
40	3.7
50	4.6
63	5.8

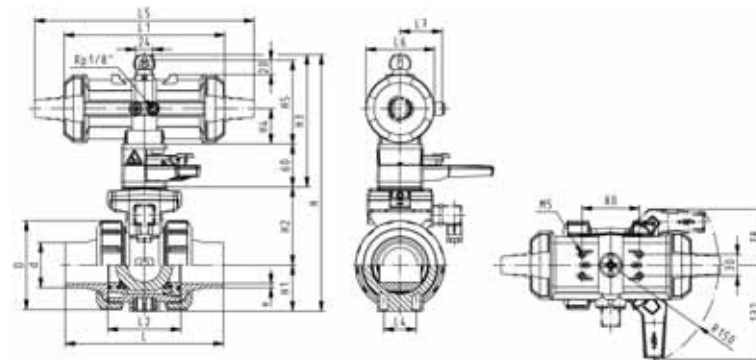



PROGEF Standard Ball valve type 231 FC (Fail safe to close) With manual override With fixed flanges PP-H serrated metric

Model:

- Material: PP-H
- Built on with pneumatic actuator PA11 (DN10/15-25), PA21 (DN32-50)
- Control time 90°<) 1-2 s
- For easy installation and removal
- Integrated stainless steel mounting inserts
- Overall length according to EN 558
- Connecting dimensions: ISO 7005 / EN 1092 / DIN 2501 PN10 / BS4504

Option:

- Individual configuration of the valve (see diagram)

d [mm]	DN [mm]	Inch	PN	kv-value ($\Delta p=1$ bar) [l/min]	EPDM Code	FPM Code	kg
20	15	½	10	185	199 231 243	199 231 253	1.700
25	20	¾	10	350	199 231 244	199 231 254	1.900
32	25	1	10	700	199 231 245	199 231 255	2.100
40	32	1 ¼	10	1000	199 231 246	199 231 256	3.400
50	40	1 ½	10	1600	199 231 247	199 231 257	3.900
63	50	2	10	3100	199 231 248	199 231 258	4.900

d [mm]	D [mm]	H [mm]	H1 [mm]	H2 [mm]	H3 [mm]	H4 [mm]	H5 [mm]	H6 [mm]	L [mm]	L1 [mm]	L2 [mm]	L3 [mm]	L4 [mm]	L5 [mm]	L6 [mm]
20	50	230	27	62	168	40	77	48	120	194	56	130	25	261	76
25	58	239	30	71	168	40	77	53	139	194	65	150	25	261	76
32	68	239	36	71	168	40	77	58	150	194	71	160	25	261	76
40	84	271	44	84	187	51	99	70	170	224	85	180	45	305	95
50	97	271	51	84	187	51	99	75	190	224	89	200	45	305	95
63	124	293	64	106	187	51	99	83	220	224	101	230	45	305	95

d [mm]	L7 [mm]
20	48
25	48
32	48
40	59
50	59
63	59

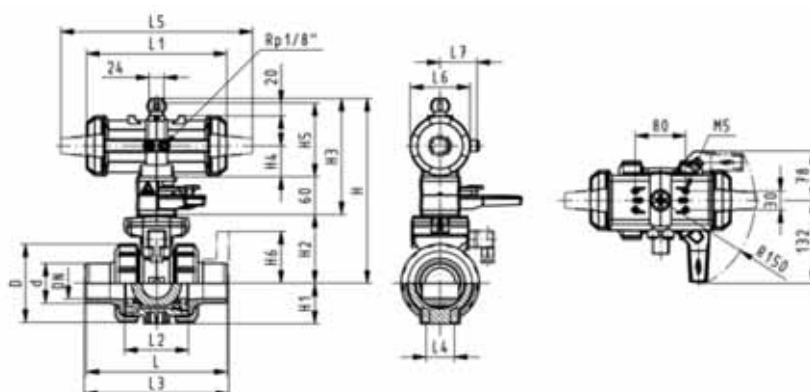



PROGEF Standard Ball valve type 231 FO (Fail safe to open) With manual override With fusion sockets metric

Model:

- Material: PP-H
- Built on with pneumatic actuator PA11 (DN10/15-25), PA21 (DN32-50)
- Control time 90°< 1-2 s
- For easy installation and removal
- Integrated stainless steel mounting inserts

Option:

- Individual configuration of the valve (see diagram)

d [mm]	DN [mm]	PN	kv-value ($\Delta p=1$ bar) [l/min]	EPDM Code	FPM Code	kg
16	10	10	70	199 231 042	199 231 052	1.500
20	15	10	185	199 231 043	199 231 053	1.500
25	20	10	350	199 231 044	199 231 054	1.600
32	25	10	700	199 231 045	199 231 055	1.700
40	32	10	1000	199 231 046	199 231 056	2.800
50	40	10	1600	199 231 047	199 231 057	3.100
63	50	10	3100	199 231 048	199 231 058	4.000

d [mm]	D [mm]	H [mm]	H1 [mm]	H2 [mm]	H3 [mm]	H4 [mm]	H5 [mm]	L [mm]	L1 [mm]	L2 [mm]	L4 [mm]	L5 [mm]	L6 [mm]	L7 [mm]	z [mm]
16	50	230	27	62	168	40	77	93	194	56	25	261	76	48	67
20	50	230	27	62	168	40	77	95	194	56	25	261	76	48	66
25	58	239	30	71	168	40	77	108	194	65	25	261	76	48	77
32	68	239	36	71	168	40	77	118	194	71	25	261	76	48	83
40	84	271	44	84	187	51	99	137	224	85	45	305	95	59	99
50	97	271	51	84	187	51	99	147	224	89	45	305	95	59	105
63	124	293	64	106	187	51	99	168	224	101	45	305	95	59	117

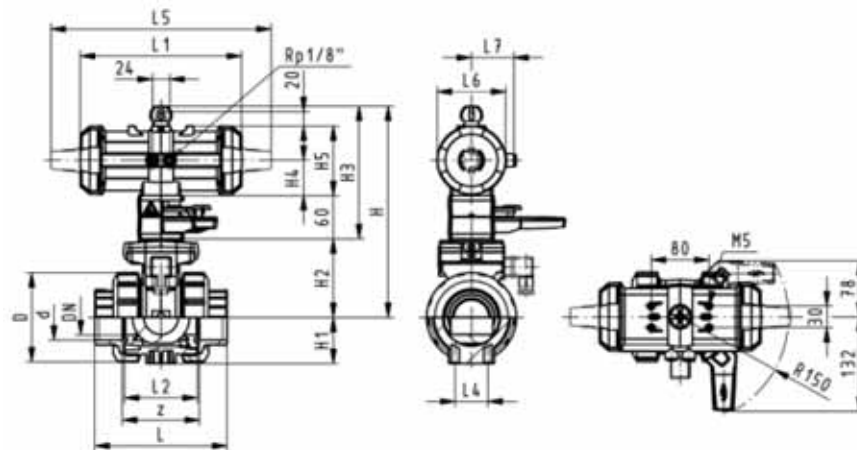



PROGEF Standard Ball valve type 231 FO (Fail safe to open) With manual override With socket fusion spigots metric

Model:

- Material: PP-H
- Built on with pneumatic actuator PA11 (DN10/15-25), PA21 (DN32-50)
- Control time 90°< 1-2 s
- For easy installation and removal
- Integrated stainless steel mounting inserts

Option:

- Individual configuration of the valve (see diagram)

d [mm]	DN [mm]	PN	kv-value ($\Delta p=1$ bar) [l/min]	EPDM Code	FPM Code	kg
16	10	10	70	199 231 062	199 231 072	1.500
20	15	10	185	199 231 063	199 231 073	1.500
25	20	10	350	199 231 064	199 231 074	1.600
32	25	10	700	199 231 065	199 231 075	1.700
40	32	10	1000	199 231 066	199 231 076	2.800
50	40	10	1600	199 231 067	199 231 077	3.100
63	50	10	3100	199 231 068	199 231 078	4.000

d [mm]	D [mm]	H [mm]	H1 [mm]	H2 [mm]	H3 [mm]	H4 [mm]	H5 [mm]	L [mm]	L1 [mm]	L2 [mm]	L3 [mm]	L4 [mm]	L5 [mm]	L6 [mm]	L7 [mm]
16	50	159	27	62	168	40	77	110	194	56	130	25	261	76	48
20	50	159	27	62	168	40	77	120	194	56	130	25	261	76	48
25	58	168	30	71	168	40	77	139	194	65	150	25	261	76	48
32	68	168	36	71	168	40	77	150	194	71	160	25	261	76	48
40	84	202	44	84	187	51	99	170	224	85	180	45	305	95	59
50	97	202	51	84	187	51	99	190	224	89	200	45	305	95	59
63	124	225	64	106	187	51	99	220	224	101	230	45	305	95	59

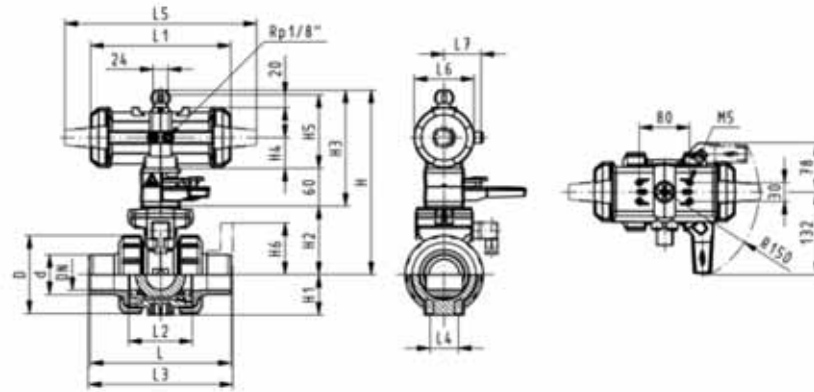



PROGEF Standard

Ball valve type 231 FO (Fail safe to open)

With manual override

With butt fusion spigots IR-Plus SDR11 metric

Model:

- Material: PP-H
- Built on with pneumatic actuator PA11 (DN10/15-25), PA21 (DN32-50)
- Control time 90°< 1-2 s
- For easy installation and removal
- Integrated stainless steel mounting inserts

Option:

- Individual configuration of the valve (see diagram)

d [mm]	DN [mm]	PN	kv-value ($\Delta p=1$ bar) [l/min]	EPDM Code	FPM Code	kg
20	15	10	185	199 231 643	199 231 653	1.500
25	20	10	350	199 231 644	199 231 654	1.600
32	25	10	700	199 231 645	199 231 655	1.700
40	32	10	1000	199 231 646	199 231 656	2.800
50	40	10	1600	199 231 647	199 231 657	3.100
63	50	10	3100	199 231 648	199 231 658	4.000

d [mm]	D [mm]	H [mm]	H1 [mm]	H2 [mm]	H3 [mm]	H4 [mm]	H5 [mm]	L [mm]	L1 [mm]	L2 [mm]	L3 [mm]	L4 [mm]	L5 [mm]	L6 [mm]	L7 [mm]
20	50	159	27	62	168	40	77	130	194	56	130	25	261	76	48
25	58	168	30	71	168	40	77	143	194	65	150	25	261	76	48
32	68	168	36	71	168	40	77	150	194	71	160	25	261	76	48
40	84	202	44	84	187	51	99	171	224	85	180	45	305	95	59
50	97	202	51	84	187	51	99	191	224	89	200	45	305	95	59
63	124	225	64	106	187	51	99	220	224	101	230	45	305	95	59

d [mm]	e [mm]
20	1.9
25	2.3
32	3.0
40	3.7
50	4.6
63	5.8

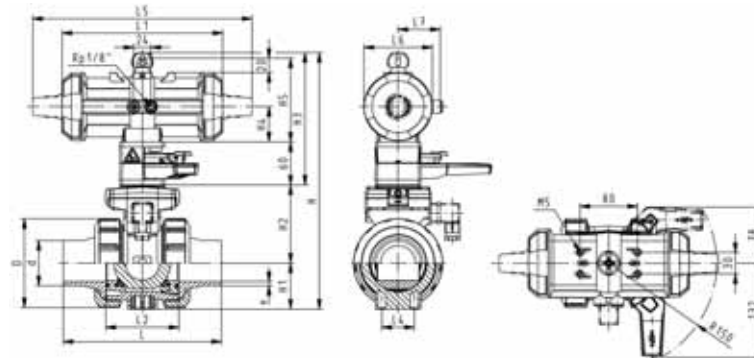



PROGEF Standard Ball valve type 231 FO (Fail safe to open) With manual override With fixed flanges PP-H serrated metric

Model:

- Material: PP-H
- Built on with pneumatic actuator PA11 (DN10/15-25), PA21 (DN32-50)
- Control time 90°< 1-2 s
- For easy installation and removal
- Integrated stainless steel mounting inserts
- Overall length according to EN 558
- Connecting dimensions: ISO 7005 / EN 1092 / DIN 2501 PN10 / BS4504

Option:

- Individual configuration of the valve (see diagram)

d [mm]	DN [mm]	Inch	PN	kv-value ($\Delta p=1$ bar) [l/min]	EPDM Code	FPM Code	kg
20	15	½	10	185	199 231 263	199 231 273	1.700
25	20	¾	10	350	199 231 264	199 231 274	1.900
32	25	1	10	700	199 231 265	199 231 275	2.100
40	32	1 ¼	10	1000	199 231 266	199 231 276	3.400
50	40	1 ½	10	1600	199 231 267	199 231 277	3.900
63	50	2	10	3100	199 231 268	199 231 278	4.900

d [mm]	D [mm]	H [mm]	H1 [mm]	H2 [mm]	H3 [mm]	H4 [mm]	H5 [mm]	H6 [mm]	L [mm]	L1 [mm]	L2 [mm]	L3 [mm]	L4 [mm]	L5 [mm]	L6 [mm]
20	58	230	27	62	168	40	77	48	120	194	56	130	25	261	76
25	58	239	30	71	168	40	77	53	139	194	65	150	25	261	76
32	68	239	36	71	168	40	77	58	150	194	71	160	25	261	76
40	84	271	44	84	187	51	99	70	170	224	85	180	45	305	95
50	97	271	51	84	187	51	99	75	190	224	89	200	45	305	95
63	124	293	64	106	187	51	99	83	220	224	101	230	45	305	95

d [mm]	L7 [mm]
20	48
25	48
32	48
40	59
50	59
63	59

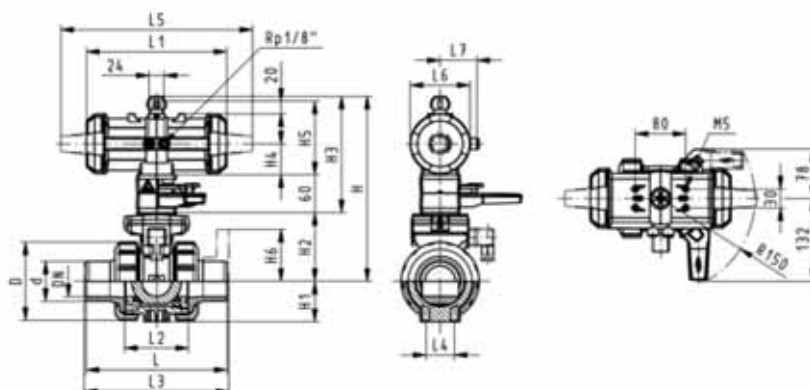



PROGEF Standard Ball valve type 231 DA (Double acting) With manual override With fusion sockets metric

Model:

- Material: PP-H
- Built on with pneumatic actuator PA11 (DN10/15-25), PA21 (DN32-50)
- Control time $90^\circ <$ 1-2 s
- For easy installation and removal
- Integrated stainless steel mounting inserts

Option:

- Individual configuration of the valve (see diagram)

d [mm]	DN [mm]	PN	kv-value ($\Delta p=1$ bar) [l/min]	EPDM Code	FPM Code	kg
16	10	10	70	199 231 082	199 231 092	1.500
20	15	10	185	199 231 083	199 231 093	1.500
25	20	10	350	199 231 084	199 231 094	1.600
32	25	10	700	199 231 085	199 231 095	1.700
40	32	10	1000	199 231 086	199 231 096	2.800
50	40	10	1600	199 231 087	199 231 097	3.100
63	50	10	3100	199 231 088	199 231 098	4.000

d [mm]	D [mm]	H [mm]	H1 [mm]	H2 [mm]	H3 [mm]	H4 [mm]	H5 [mm]	L [mm]	L1 [mm]	L2 [mm]	L4 [mm]	L5 [mm]	L6 [mm]	L7 [mm]	z [mm]
16	50	159	27	62	168	40	77	93	194	56	25	261	76	48	67
20	50	159	27	62	168	40	77	95	194	56	25	261	76	48	66
25	58	168	30	71	168	40	77	108	194	65	25	261	76	48	77
32	68	168	36	71	168	40	77	118	194	71	25	261	76	48	83
40	84	202	44	84	187	51	99	137	224	85	45	305	95	59	99
50	97	202	51	84	187	51	99	147	224	89	45	305	95	59	105
63	124	225	64	106	187	51	99	168	224	101	45	305	95	59	117

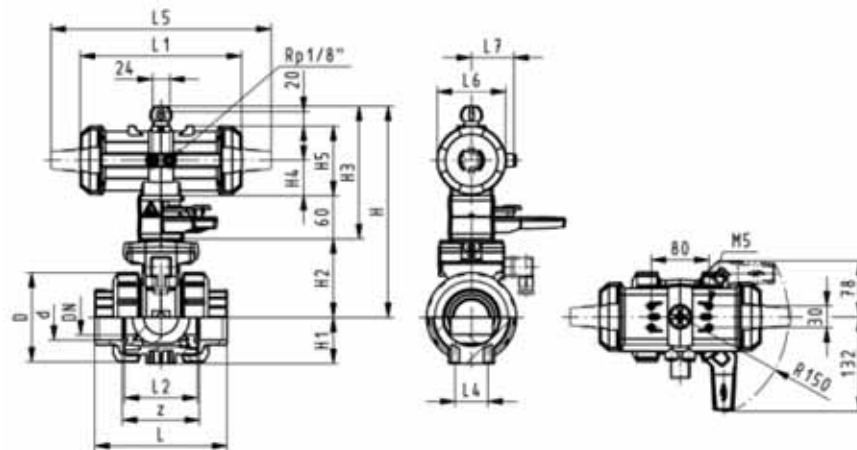



**PROGEF Standard
Ball valve type 231 DA (Double acting)
With manual override
With socket fusion spigots metric**

Model:

- Material: PP-H
- Built on with pneumatic actuator PA11 (DN10/15-25), PA21 (DN32-50)
- Control time 90°<) 1-2 s
- For easy installation and removal
- Integrated stainless steel mounting inserts

Option:

- Individual configuration of the valve (see diagram)

d [mm]	DN [mm]	PN	kv-value ($\Delta p=1$ bar) [l/min]	EPDM Code	FPM Code	kg
16	10	10	70	199 231 102	199 231 112	1.500
20	15	10	185	199 231 103	199 231 113	1.500
25	20	10	350	199 231 104	199 231 114	1.600
32	25	10	700	199 231 105	199 231 115	1.700
40	32	10	1000	199 231 106	199 231 116	2.800
50	40	10	1600	199 231 107	199 231 117	3.100
63	50	10	3100	199 231 108	199 231 118	4.000

d [mm]	D [mm]	H [mm]	H1 [mm]	H2 [mm]	H3 [mm]	H4 [mm]	H5 [mm]	L [mm]	L1 [mm]	L2 [mm]	L3 [mm]	L4 [mm]	L5 [mm]	L6 [mm]	L7 [mm]
16	50	159	27	62	168	40	77	110	194	56		25	261	76	48
20	50	159	27	62	168	40	77	120	194	56	130	25	261	76	48
25	58	168	30	71	168	40	77	139	194	65	150	25	261	76	48
32	68	168	36	71	168	40	77	150	194	71	160	25	261	76	48
40	84	202	44	84	187	51	99	170	224	85	180	45	305	95	59
50	97	202	51	84	187	51	99	190	224	89	200	45	305	95	59
63	124	225	64	106	187	51	99	220	224	101	230	45	305	95	59

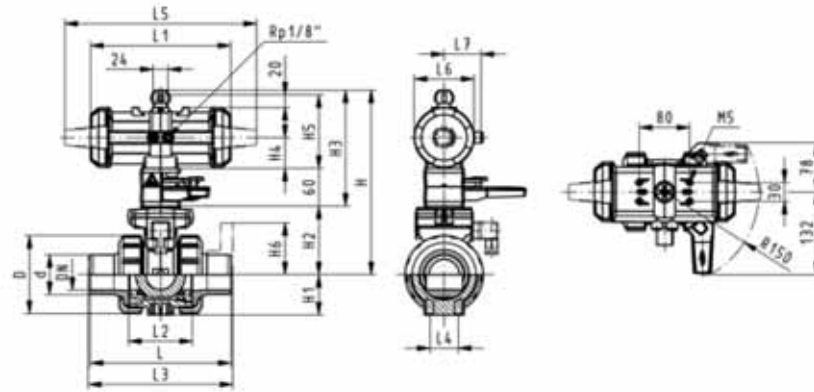



PROGEF Standard
Ball valve type 231 DA (Double acting)
With manual override
With butt fusion spigots IR-Plus SDR11 metric

Model:

- Material: PP-H
- Built on with pneumatic actuator PA11 (DN10/15-25), PA21 (DN32-50)
- Control time 90°< 1-2 s
- For easy installation and removal
- Integrated stainless steel mounting inserts

Option:

- Individual configuration of the valve (see diagram)

d [mm]	DN [mm]	PN	kv-value ($\Delta p=1$ bar) [l/min]	EPDM Code	FPM Code	kg
20	15	10	185	199 231 663	199 231 673	1.500
25	20	10	350	199 231 664	199 231 674	1.600
32	25	10	700	199 231 665	199 231 675	1.700
40	32	10	1000	199 231 666	199 231 676	2.800
50	40	10	1600	199 231 667	199 231 677	3.100
63	50	10	3100	199 231 668	199 231 678	4.000

d [mm]	D [mm]	H [mm]	H1 [mm]	H2 [mm]	H3 [mm]	H4 [mm]	H5 [mm]	L [mm]	L1 [mm]	L2 [mm]	L3 [mm]	L4 [mm]	L5 [mm]	L6 [mm]	L7 [mm]
20	50	159	27	62	168	40	77	130	194	56	130	25	261	76	48
25	58	168	30	71	168	40	77	143	194	65	150	25	261	76	48
32	68	168	36	71	168	40	77	150	194	71	160	25	261	76	48
40	84	202	44	84	187	51	99	171	224	85	180	45	305	95	59
50	97	202	51	84	187	51	99	191	224	89	200	45	305	95	59
63	124	225	64	106	187	51	99	220	224	101	230	45	305	95	59

d [mm]	e [mm]
20	1.9
25	2.3
32	3.0
40	3.7
50	4.6
63	5.8

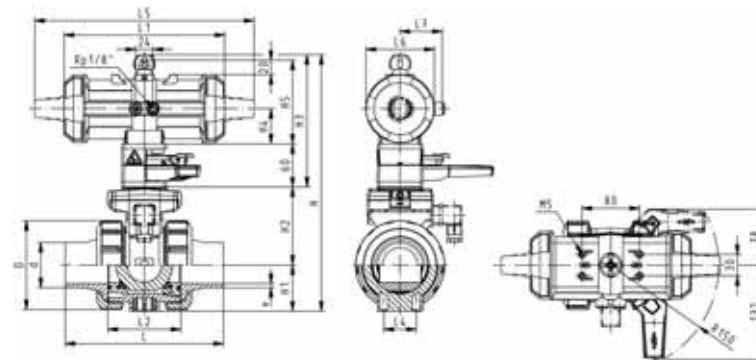



PROGEF Standard Ball valve type 231 DA (Double acting) With manual override With fixed flanges PP-H serrated metric

Model:

- Material: PP-H
- Built on with pneumatic actuator PA11 (DN10/15-25), PA21 (DN32-50)
- Control time 90°< 1-2 s
- For easy installation and removal
- Integrated stainless steel mounting inserts
- Overall length according to EN 558
- Connecting dimensions: ISO 7005 / EN 1092 / DIN 2501 PN10 / BS4504

Option:

- Individual configuration of the valve (see diagram)

d [mm]	DN [mm]	Inch	PN	kv-value ($\Delta p=1$ bar) [l/min]	EPDM Code	FPM Code	kg
20	15	½	10	185	199 231 283	199 231 293	1.700
25	20	¾	10	350	199 231 284	199 231 294	1.900
32	25	1	10	700	199 231 285	199 231 295	2.100
40	32	1 ¼	10	1000	199 231 286	199 231 296	3.400
50	40	1 ½	10	1600	199 231 287	199 231 297	3.900
63	50	2	10	3100	199 231 288	199 231 298	4.900

d [mm]	D [mm]	H [mm]	H1 [mm]	H2 [mm]	H3 [mm]	H4 [mm]	H5 [mm]	H6 [mm]	L [mm]	L1 [mm]	L2 [mm]	L3 [mm]	L4 [mm]	L5 [mm]	L6 [mm]
20	50	230	27	62	168	40	77	48	120	194	56	130	25	261	76
25	58	239	30	71	168	40	77	53	139	194	65	150	25	261	76
32	68	239	36	71	168	40	77	58	150	194	71	160	25	261	76
40	84	271	44	84	187	51	99	70	170	224	85	180	45	305	95
50	97	271	51	84	187	51	99	75	190	224	89	200	45	305	95
63	124	293	64	106	187	51	99	83	220	224	101	230	45	305	95

d [mm]	L7 [mm]
20	48
25	48
32	48
40	59
50	59
63	59

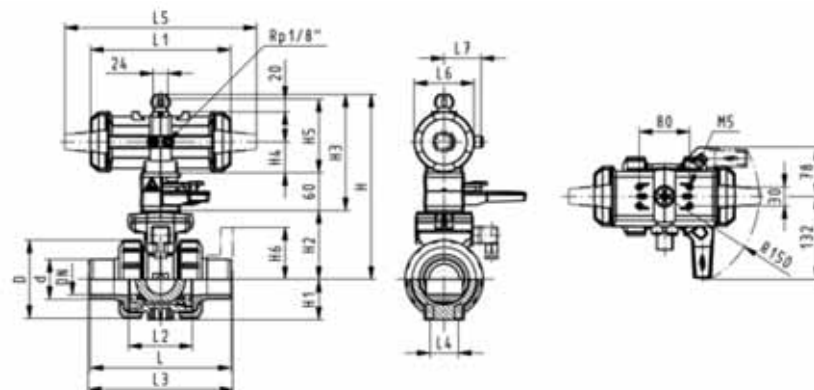



DN10/15 - 50



PROGEF Standard Ball valve type 231 FC (Fail safe to close) Without manual override With fusion sockets metric

Model:

- Material: PP-H
- For easy installation and removal
- Integrated stainless steel mounting inserts
- Control time 90° < 1-2 s
- Assignment of actuators: PA11 (DN10/15-25), PA21 (DN32-50), PA30 (DN65), PA40 (DN80), PA40 (DN100)

Option:

- Individual configuration of the valve (see diagram)

d [mm]	DN [mm]	PN	kv-value ($\Delta p=1$ bar) [l/min]	EPDM Code	FPM Code	kg
16	10	10	70	199 231 122	199 231 132	1.200
20	15	10	185	199 231 123	199 231 133	0.996
25	20	10	350	199 231 124	199 231 134	1.300
32	25	10	700	199 231 125	199 231 135	1.129
40	32	10	1000	199 231 126	199 231 136	2.500
50	40	10	1600	199 231 127	199 231 137	2.800
63	50	10	3100	199 231 128	199 231 138	3.700
75	65	10	5000	199 231 129	199 231 139	5.142
90	80	10	7000	199 231 130	199 231 140	8.057
110	100	10	11000	199 231 131	199 231 141	12.600

d [mm]	D [mm]	H [mm]	H1 [mm]	H2 [mm]	H5 [mm]	L [mm]	L1 [mm]	L2 [mm]	L4 [mm]	L5 [mm]	L6 [mm]	L7 [mm]	z [mm]
16	50	159	27	62	77	93	194	56	25	261	76	48	67
20	50	159	27	62	77	95	194	56	25	261	76	48	66
25	58	168	30	71	77	108	194	65	25	261	76	48	77
32	68	168	36	71	77	118	194	71	25	261	76	48	83
40	84	202	44	84	99	137	224	85	45	305	95	59	99
50	97	202	51	84	99	147	224	89	45	305	95	59	105
63	124	225	64	106	99	168	224	101	45	305	95	59	117
75	166	262	85	156	70	233		136	70	276	65		167
90	200	281	105	168	78	254		141	70	341	72		180
110	238	292	123	175	86	301		164	120	369	80		215

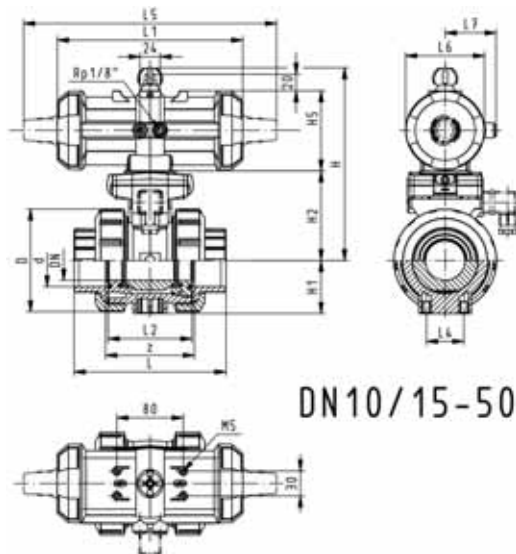

DN10/15-50

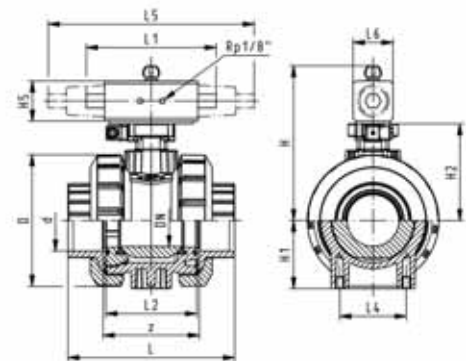

DN65-100



DN10/15 - 50



PROGEF Standard Ball valve type 231 FC (Fail safe to close) Without manual override With socket fusion spigots metric

Model:

- Material: PP-H
- For easy installation and removal
- Integrated stainless steel mounting inserts
- Control time $90^\circ <$ 1-2 s
- Assignment of actuators: PA11 (DN10/15-25), PA21 (DN32-50), PA30 (DN65), PA40 (DN80), PA40 (DN100)

Option:

- Individual configuration of the valve (see diagram)

d [mm]	DN [mm]	PN	kv-value ($\Delta p=1$ bar) [l/min]	EPDM Code	FPM Code	kg
16	10	10	70	199 231 142	199 231 152	1.200
20	15	10	185	199 231 143	199 231 153	1.004
25	20	10	350	199 231 144	199 231 154	1.300
32	25	10	700	199 231 145	199 231 155	0.001
40	32	10	1000	199 231 146	199 231 156	2.035
50	40	10	1600	199 231 147	199 231 157	2.228
63	50	10	3100	199 231 148	199 231 158	3.700
75	65	10	5000	199 231 149	199 231 159	6.600
90	80	10	7000	199 231 150	199 231 160	8.400
110	100	10	11000	199 231 151	199 231 161	12.600

d [mm]	D [mm]	H [mm]	H1 [mm]	H2 [mm]	H5 [mm]	L [mm]	L1 [mm]	L2 [mm]	L3 [mm]	L4 [mm]	L5 [mm]	L6 [mm]	L7 [mm]
16	50	159	27	62	77	110	194	56	130	25	261	76	48
20	50	159	27	62	77	120	194	56	130	25	261	76	48
25	58	168	30	71	77	139	194	65	150	25	261	76	48
32	68	168	36	71	77	150	194	71	160	25	261	76	48
40	84	202	44	84	99	170	224	85	180	45	305	95	59
50	97	202	51	84	99	190	224	89	200	45	305	95	59
63	124	225	64	106	99	220	224	101	230	45	305	95	59
75	166	262	85	156	70	280		136	290	70	276	65	
90	200	281	105	168	78	296		141	310	70	341	72	
110	238	292	123	175	86	336		164	350	120	369	80	

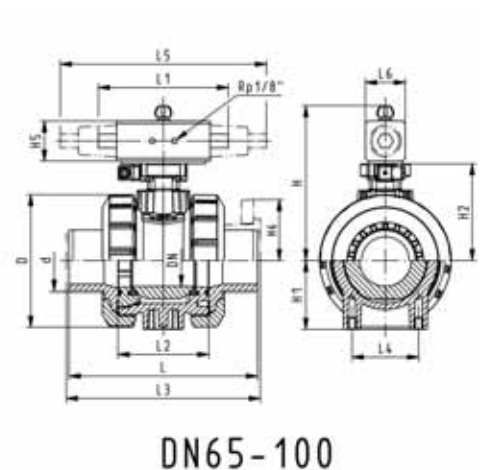
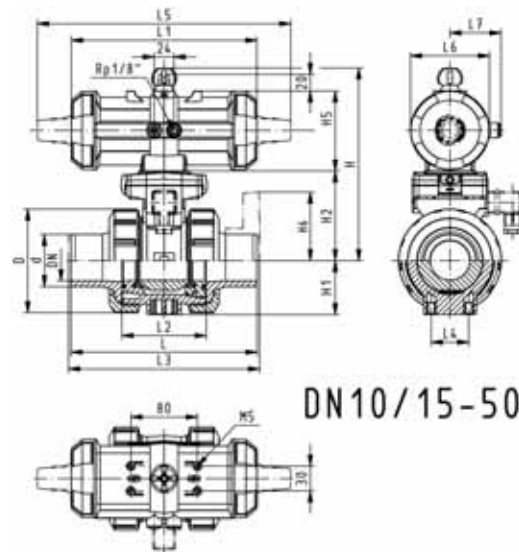



DN10/15 - 50

PROGEF Standard Ball valve type 231 FC (Fail safe to close) Without manual override With fixed flanges PP-H serrated metric

Model:

- Material: PP-H
- For easy installation and removal
- Integrated stainless steel mounting inserts
- Control time $90^\circ <$ 1-2 s
- Built on with pneumatic actuator PA11 (DN10/15-25), PA21 (DN32-50)
- Overall length according to EN 558
- Connecting dimensions: ISO 7005 / EN 1092 / DIN 2501 PN10 / BS4504

Option:

- Individual configuration of the valve (see diagram)

d [mm]	DN [mm]	Inch	PN	kv-value ($\Delta p=1$ bar) [l/min]	EPDM Code	FPM Code	kg
20	15	½	10	185	199 231 423	199 231 433	1.400
25	20	¾	10	350	199 231 424	199 231 434	1.600
32	25	1	10	700	199 231 425	199 231 435	1.377
40	32	1 ¼	10	1000	199 231 426	199 231 436	3.100
50	40	1 ½	10	1600	199 231 427	199 231 437	3.600
63	50	2	10	3100	199 231 428	199 231 438	4.700

d [mm]	D [mm]	H [mm]	H1 [mm]	H2 [mm]	H4 [mm]	H5 [mm]	H6 [mm]	L [mm]	L1 [mm]	L2 [mm]	L3 [mm]	L4 [mm]	L5 [mm]	L6 [mm]	L7 [mm]
20	50	159	27	62	40	77	48	120	194	56	130	25	261	76	48
25	58	168	30	71	40	77	53	140	194	65	150	25	261	76	48
32	68	168	36	71	40	77	58	150	194	71	160	25	261	76	48
40	84	202	44	84	51	99	70	170	224	85	180	45	305	95	59
50	97	202	51	84	51	99	75	190	224	89	200	45	305	95	59
63	124	225	64	106	51	99	83	220	224	101	230	45	305	95	59

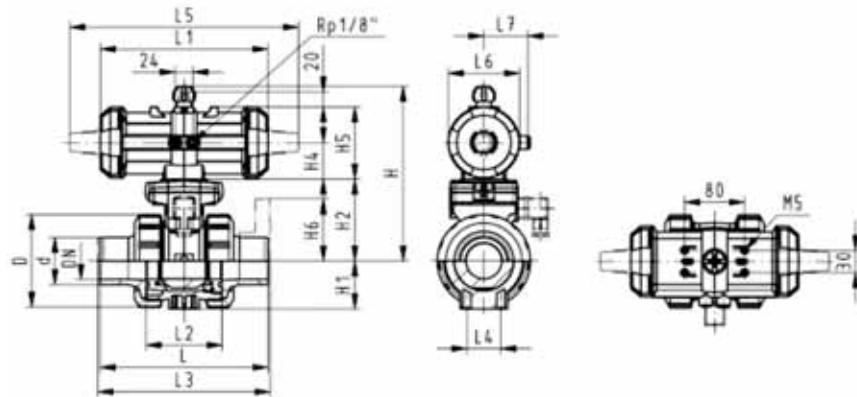



**PROGEF Standard
Ball valve type 231 FC (Fail safe to close)
Without manual override
With backing flanges PP-st metric**

Model:

- Material: PP-H
- For easy installation and removal
- Integrated stainless steel mounting inserts
- Control time 90°<) 1-2 s
- Assignment of actuators: PA11 (DN10/15-25), PA21 (DN32-50), PA30 (DN65), PA40 (DN80), PA40 (DN100)
- Overall length according to EN 558
- Connecting dimension: ISO 7005, EN 1092, BS 4504, DIN 2501

Option:

- Individual configuration of the valve (see diagram)

d [mm]	DN [mm]	Inch	PN	kv-value ($\Delta p=1$ bar) [l/min]	EPDM Code	FPM Code	kg
75	65	2 ½	10	5000	199 231 329	199 231 339	5.228
90	80	3	10	7000	199 231 330	199 231 340	13.600
110	100	4	10	11000	199 231 331	199 231 341	19.800

d [mm]	D [mm]	H [mm]	H1 [mm]	H2 [mm]	H5 [mm]	H6 [mm]	L [mm]	L2 [mm]	L3 [mm]	L4 [mm]	L5 [mm]	L6 [mm]
75	166	262	85	156	70	93	280	136	290	70	276	65
90	200	281	105	168	78	100	296	141	310	70	341	72
110	238	292	123	175	86	110	336	164	350	120	369	80

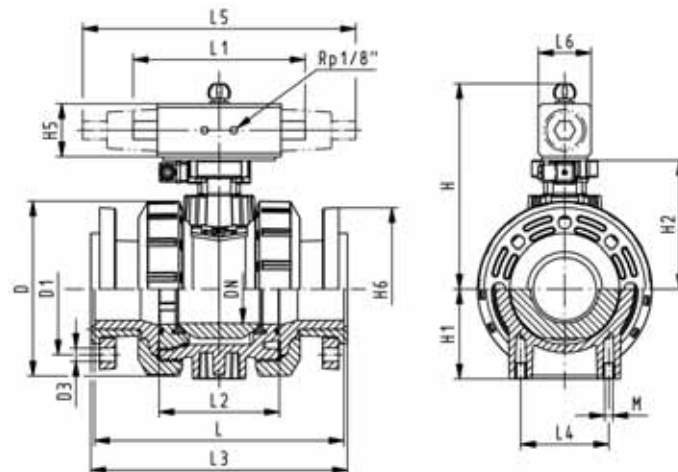



DN10/15 - 50



PROGEF Standard

Ball valve type 231 FC (Fail safe to close)

Without manual override

With butt fusion spigots IR-Plus SDR11 metric

Model:

- Material: PP-H
- For easy installation and removal
- Integrated stainless steel mounting inserts
- Control time 90°< 1-2 s
- Assignment of actuators: PA11 (DN10/15-25), PA21 (DN32-50), PA30 (DN65), PA40 (DN80), PA40 (DN100)

Option:

- Individual configuration of the valve (see diagram)

d [mm]	DN [mm]	PN	kv-value ($\Delta p=1$ bar) [l/min]	EPDM Code	FPM Code	kg
20	15	10	185	199 231 833	199 231 843	1.000
25	20	10	350	199 231 834	199 231 844	1.300
32	25	10	700	199 231 835	199 231 845	1.400
40	32	10	1000	199 231 836	199 231 846	2.500
50	40	10	1600	199 231 837	199 231 847	2.800
63	50	10	3100	199 231 838	199 231 848	2.789
75	65	10	5000	199 231 839	199 231 849	6.600
90	80	10	7000	199 231 840	199 231 850	8.400
110	100	10	11000	199 231 841	199 231 851	12.600

d [mm]	D [mm]	H [mm]	H1 [mm]	H2 [mm]	H5 [mm]	L [mm]	L1 [mm]	L2 [mm]	L3 [mm]	L4 [mm]	L5 [mm]	L6 [mm]	e [mm]
20	50	159	27	62	77	130	194.0	56	130	25	261	76	1.9
25	58	168	30	71	77	143	194.0	65	150	25	261	76	2.3
32	68	168	36	71	77	150	194.0	71	160	25	261	76	3.0
40	84	202	44	84	99	171	224.0	85	180	45	305	95	3.7
50	97	202	51	84	99	191	224.0	89	200	45	305	95	4.6
63	142	225	64	106	99	220	224.0	101	230	45	305	95	5.8
75	166	262	85	156	70	266	270.0	136	290	70	276	65	8.2
90	200	281	105	168	78	264	270.0	141	310	70	341	72	9.9
110	238	292	123	175	86	301	320.0	164	350	120	369	80	12.0

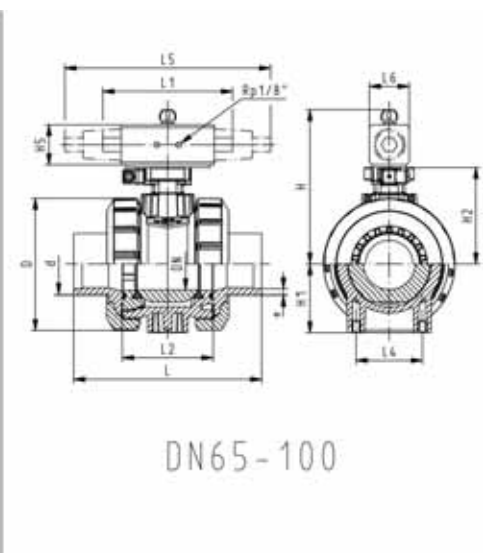
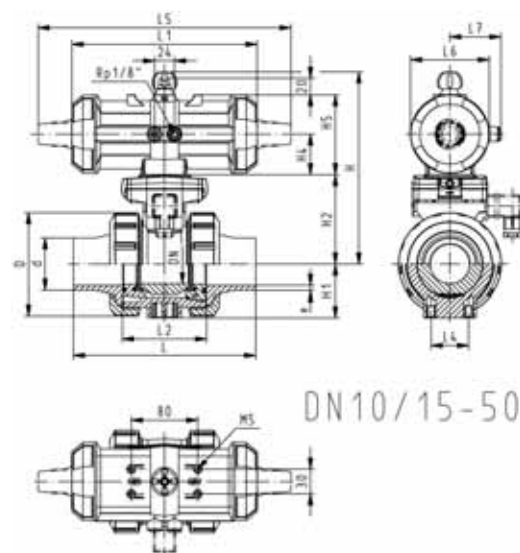



DN10/15 - 50



PROGEF Standard Ball valve type 231 FC (Fail safe to close) Without manual override With butt fusion spigots SDR17.6 metric

Model:

- Material: PP-H
- For easy installation and removal
- Integrated stainless steel mounting inserts
- Control time $90^\circ <$ 1-2 s
- Assignment of actuators: PA11 (DN10/15-25), PA21 (DN32-50), PA30 (DN65), PA40 (DN80), PA40 (DN100)

Option:

- Individual configuration of the valve (see diagram)

d [mm]	DN [mm]	PN	kv-value ($\Delta p=1$ bar) [l/min]	EPDM Code	FPM Code	kg
50	40	10	1600	199 231 937	199 231 947	
63	50	10	3100	199 231 938	199 231 948	
75	65	10	5000	199 231 939	199 231 949	6.600
90	80	10	7000	199 231 940	199 231 950	8.400
110	100	10	11000	199 231 941	199 231 951	12.600

d [mm]	D [mm]	H [mm]	H1 [mm]	H2 [mm]	H5 [mm]	L [mm]	L2 [mm]	L3 [mm]	L4 [mm]	L5 [mm]	L6 [mm]	e [mm]
50	97	202	51	84	99	191	89	200	45	305	95	2.9
63	142	225	64	106	99	220	101	230	45	305	95	3.6
75	166	262	85	156	70	266	136	290	70	276	65	4.6
90	200	281	105	168	78	264	141	310	70	341	72	5.5
110	238	292	123	175	86	301	164	350	120	369	80	6.7

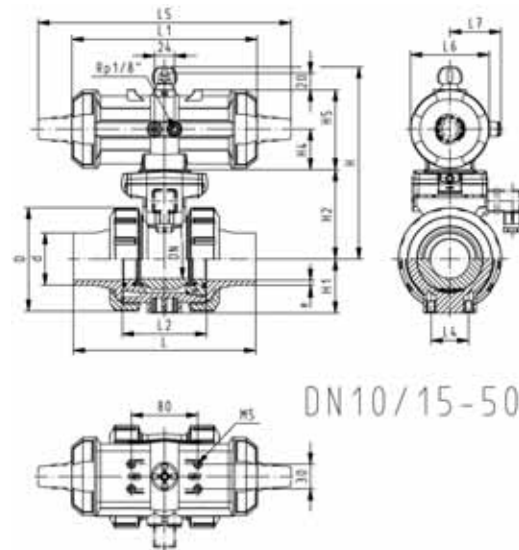

DN10/15-50

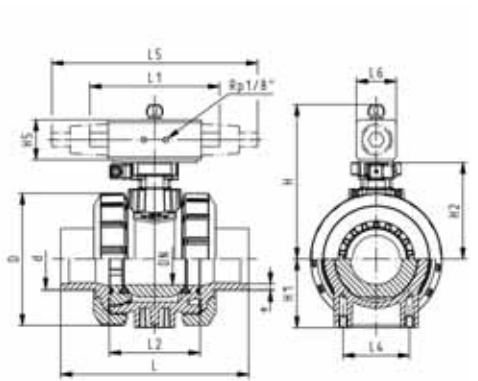

DN65-100



DN10/15 - 50



PROGEF Standard Ball valve type 231 FO (Fail safe to open) Without manual override With fusion sockets metric

Model:

- Material: PP-H
- For easy installation and removal
- Integrated stainless steel mounting inserts
- Control time $90^\circ <$ 1-2 s
- Assignment of actuators: PA11 (DN10/15-25), PA21 (DN32-50), PA30 (DN65), PA40 (DN80), PA40 (DN100)

Option:

- Individual configuration of the valve (see diagram)

d [mm]	DN [mm]	PN	kv-value ($\Delta p=1$ bar) [l/min]	EPDM Code	FPM Code	kg
16	10	10	70	199 231 162	199 231 172	1.200
20	15	10	185	199 231 163	199 231 173	1.200
25	20	10	350	199 231 164	199 231 174	1.300
32	25	10	700	199 231 165	199 231 175	1.400
40	32	10	1000	199 231 166	199 231 176	2.500
50	40	10	1600	199 231 167	199 231 177	2.800
63	50	10	3100	199 231 168	199 231 178	3.700
75	65	10	5000	199 231 169	199 231 179	6.600
90	80	10	7000	199 231 170	199 231 180	8.400
110	100	10	11000	199 231 171	199 231 181	12.600

d [mm]	D [mm]	H [mm]	H1 [mm]	H2 [mm]	H5 [mm]	L [mm]	L1 [mm]	L2 [mm]	L4 [mm]	L5 [mm]	L6 [mm]	L7 [mm]	z [mm]
16	50	159	27	62	77	93	194	56	25	261	76	48	66
20	50	159	27	62	77	95	194	56	25	261	76	48	67
25	58	168	30	71	77	108	194	65	25	261	76	48	77
32	68	168	36	71	77	118	194	71	25	261	76	48	83
40	84	202	44	84	99	137	224	85	45	305	95	59	99
50	97	202	51	84	99	147	224	89	45	305	95	59	105
63	124	225	64	106	99	168	224	101	45	305	95	59	117
75	166	262	85	156	70	233		136	70	276	65		167
90	200	281	105	168	78	254		141	70	341	72		180
110	238	292	123	175	86	301		164	120	369	80		215

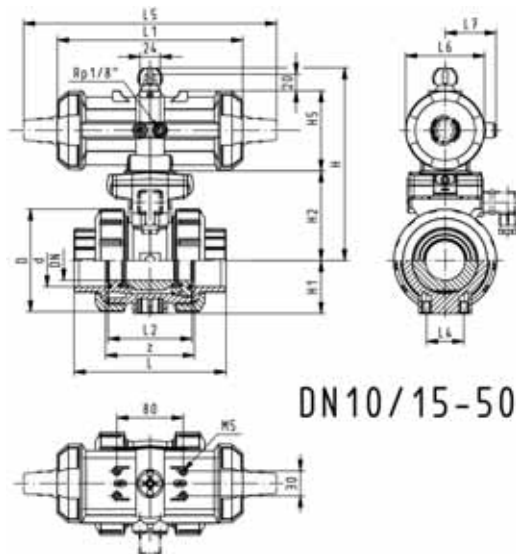

DN10/15-50

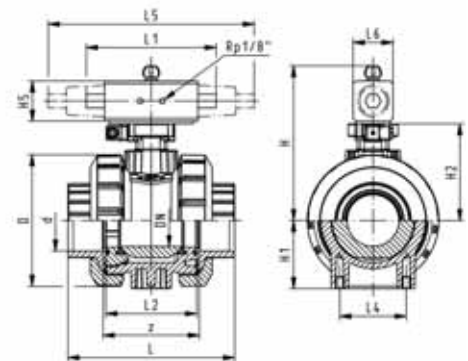

DN65-100



DN10/15 - 50



PROGEF Standard Ball valve type 231 FO (Fail safe to open) Without manual override With socket fusion spigots metric

Model:

- Material: PP-H
- For easy installation and removal
- Integrated stainless steel mounting inserts
- Control time $90^\circ <$ 1-2 s
- Assignment of actuators: PA11 (DN10/15-25), PA21 (DN32-50), PA30 (DN65), PA40 (DN80), PA40 (DN100)

Option:

- Individual configuration of the valve (see diagram)

d [mm]	DN [mm]	PN	kv-value ($\Delta p=1$ bar) [l/min]	EPDM Code	FPM Code	kg
16	10	10	70	199 231 182	199 231 192	1.200
20	15	10	185	199 231 183	199 231 193	1.200
25	20	10	350	199 231 184	199 231 194	1.300
32	25	10	700	199 231 185	199 231 195	1.400
40	32	10	1000	199 231 186	199 231 196	2.500
50	40	10	1600	199 231 187	199 231 197	2.800
63	50	10	3100	199 231 188	199 231 198	3.700
75	65	10	5000	199 231 189	199 231 199	6.600
90	80	10	7000	199 231 190	199 231 200	8.400
110	100	10	11000	199 231 191	199 231 201	12.600

d [mm]	D [mm]	H [mm]	H1 [mm]	H2 [mm]	H5 [mm]	L [mm]	L1 [mm]	L2 [mm]	L3 [mm]	L4 [mm]	L5 [mm]	L6 [mm]	L7 [mm]
16	50	159	27	62	77	110	194	56	130	25	261	76	48
20	50	159	27	62	77	120	194	56	130	25	261	76	48
25	58	168	30	71	77	139	194	65	150	25	261	76	48
32	68	168	36	71	77	150	194	71	160	25	261	76	48
40	84	202	44	84	99	170	224	85	180	45	305	95	59
50	97	202	51	84	99	190	224	89	200	45	305	95	59
63	124	225	64	106	99	220	224	101	230	45	305	95	59
75	166	262	85	156	70	280		136	290	70	276	65	
90	200	281	105	168	78	296		141	310	70	341	72	
110	238	292	123	175	86	336		164	350	120	369	80	

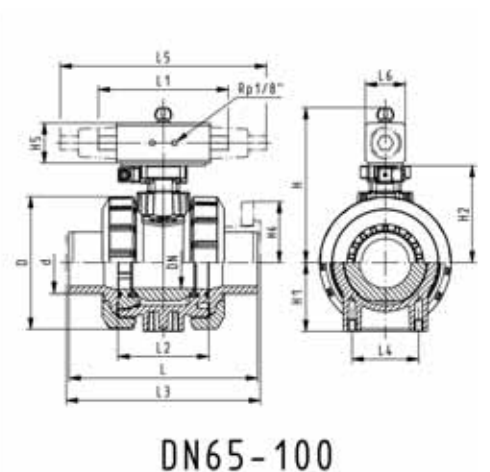
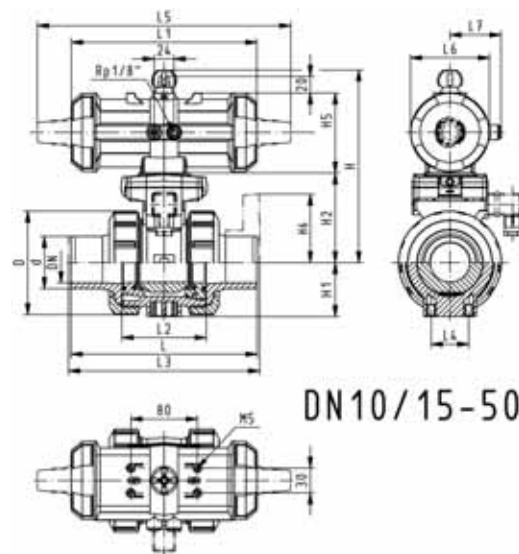



DN10/15 - 50

PROGEF Standard Ball valve type 231 FO (Fail safe to open) Without manual override With fixed flanges PP-H serrated metric

Model:

- Material: PP-H
- For easy installation and removal
- Integrated stainless steel mounting inserts
- Control time $90^\circ <$ 1-2 s
- Built on with pneumatic actuator PA11 (DN10/15-25), PA21 (DN32-50)
- Overall length according to EN 558
- Connecting dimensions: ISO 7005 / EN 1092 / DIN 2501 PN10 / BS4504

Option:

- Individual configuration of the valve (see diagram)

d [mm]	DN [mm]	Inch	PN	kv-value ($\Delta p=1$ bar) [l/min]	EPDM Code	FPM Code	kg
20	15	½	10	185	199 231 443	199 231 453	1.400
25	20	¾	10	350	199 231 444	199 231 454	1.600
32	25	1	10	700	199 231 445	199 231 455	1.800
40	32	1 ¼	10	1000	199 231 446	199 231 456	0.001
50	40	1 ½	10	1600	199 231 447	199 231 457	3.600
63	50	2	10	3100	199 231 448	199 231 458	4.700

d [mm]	D [mm]	H [mm]	H1 [mm]	H2 [mm]	H4 [mm]	H5 [mm]	H6 [mm]	L [mm]	L1 [mm]	L2 [mm]	L3 [mm]	L4 [mm]	L5 [mm]	L6 [mm]	L7 [mm]
20	50	159	27	62	40	77	48	120	194	56	130	25	261	76	48
25	58	168	30	71	40	77	53	140	194	65	150	25	261	76	48
32	68	168	36	71	40	77	58	150	194	71	160	25	261	76	48
40	84	202	44	84	51	99	70	170	224	85	180	45	305	95	59
50	97	202	51	84	51	99	75	190	224	89	200	45	305	95	59
63	124	225	64	106	51	99	83	220	224	101	230	45	305	95	59

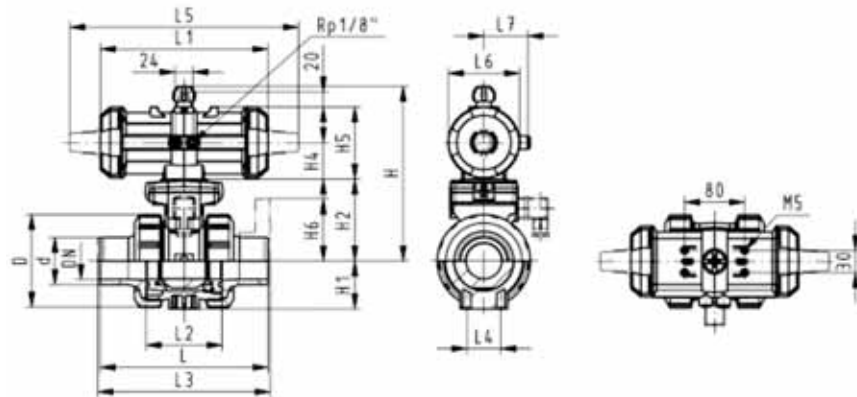



**PROGEF Standard
Ball valve type 231 FO (Fail safe to open)
Without manual override
With backing flanges PP-st metric**

Model:

- Material: PP-H
- For easy installation and removal
- Integrated stainless steel mounting inserts
- Control time 90°<) 1-2 s
- Assignment of actuators: PA11 (DN10/15-25), PA21 (DN32-50), PA30 (DN65), PA40 (DN80), PA40 (DN100)
- Overall length according to EN 558
- Connecting dimension: ISO 7005, EN 1092, BS 4504, DIN 2501

Option:

- Individual configuration of the valve (see diagram)

d [mm]	DN [mm]	Inch	PN	kv-value ($\Delta p=1$ bar) [l/min]	EPDM Code	FPM Code	kg
75	65	2 1/2	10	5000	199 231 349	199 231 359	10.900
90	80	3	10	7000	199 231 350	199 231 360	13.600
110	100	4	10	11000	199 231 351	199 231 361	19.800

d [mm]	D [mm]	H [mm]	H1 [mm]	H2 [mm]	H5 [mm]	H6 [mm]	L [mm]	L2 [mm]	L3 [mm]	L4 [mm]	L5 [mm]	L6 [mm]
75	166	262	85	156	70	93	280	136	290	70	276	65
90	200	281	105	168	78	100	296	141	310	70	341	72
110	238	292	123	175	86	110	336	164	350	120	369	80

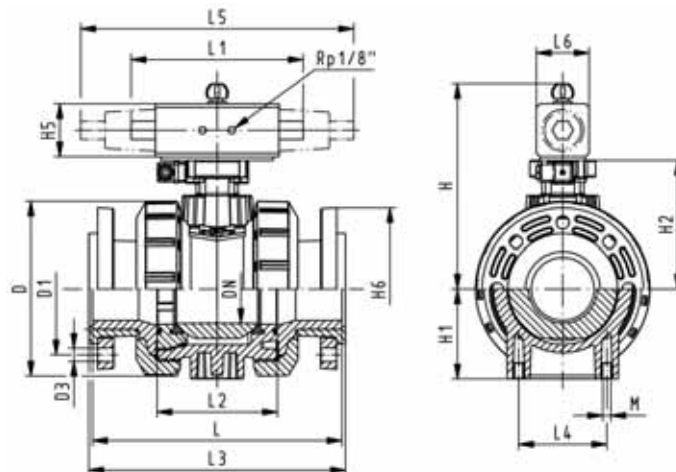



DN10/15 - 50



PROGEF Standard Ball valve type 231 FO (Fail safe to open) Without manual override With butt fusion spigots IR-Plus SDR11 metric

Model:

- Material: PP-H
- For easy installation and removal
- Integrated stainless steel mounting inserts
- Control time $90^\circ <$ 1-2 s
- Assignment of actuators: PA11 (DN10/15-25), PA21 (DN32-50), PA30 (DN65), PA40 (DN80), PA40 (DN100)

Option:

- Individual configuration of the valve (see diagram)

d [mm]	DN [mm]	PN	kv-value ($\Delta p=1$ bar) [l/min]	EPDM Code	FPM Code	kg
20	15	10	185	199 231 853	199 231 863	1.200
25	20	10	350	199 231 854	199 231 864	1.300
32	25	10	700	199 231 855	199 231 865	1.400
40	32	10	1000	199 231 856	199 231 866	2.032
50	40	10	1600	199 231 857	199 231 867	2.800
63	50	10	3100	199 231 858	199 231 868	2.791
75	65	10	5000	199 231 859	199 231 869	6.600
90	80	10	7000	199 231 860	199 231 870	8.400
110	100	10	11000	199 231 861	199 231 871	12.600

d [mm]	D [mm]	H [mm]	H1 [mm]	H2 [mm]	H5 [mm]	L [mm]	L1 [mm]	L2 [mm]	L3 [mm]	L4 [mm]	L5 [mm]	L6 [mm]	e [mm]
20	50	159	27	62	77	120	194	56	130	25	261	76	1.9
25	58	168	30	71	77	139	194	65	150	25	261	76	2.3
32	68	168	36	71	77	150	194	71	160	25	261	76	3.0
40	84	202	44	84	99	170	224	85	180	45	305	95	3.7
50	97	202	51	84	99	190	224	89	200	45	305	95	4.6
63	124	225	64	106	99	220	224	101	230	45	305	95	5.8
75	166	262	85	156	70	266	218	136	290	70	276	65	8.2
90	200	281	105	168	78	264	259	141	310	70	341	72	9.9
110	238	292	123	175	86	301	287	164	350	120	369	80	12.0

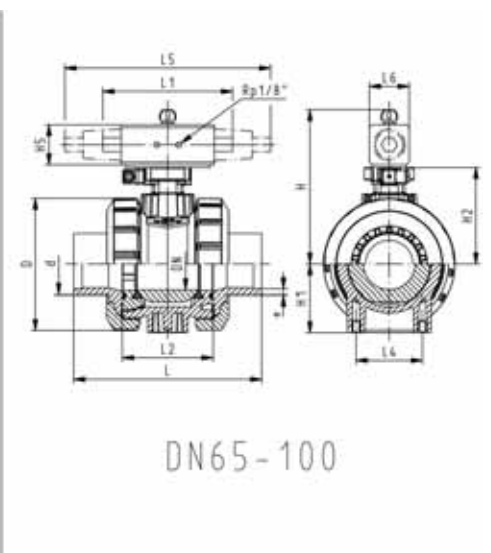
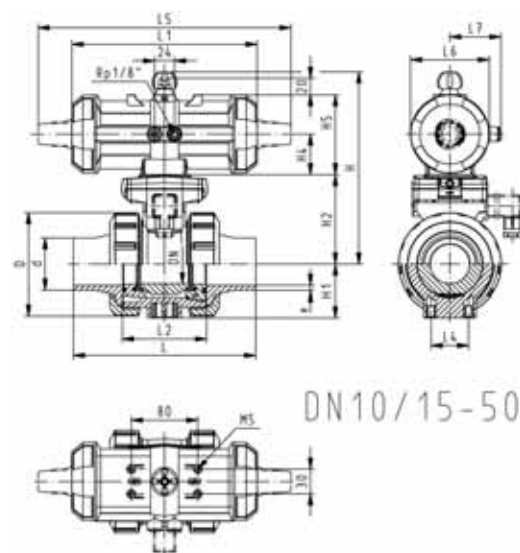



DN10/15 - 50



PROGEF Standard Ball valve type 231 DA (Double acting) Without manual override With fusion sockets metric

Model:

- Material: PP-H
- For easy installation and removal
- Integrated stainless steel mounting inserts
- Control time $90^\circ <$ 1-2 s
- Assignment of actuators: PA11 (DN10/15-25), PA21 (DN32-50), PA35 (DN65), PA40 (DN80), PA45 (DN100)

Option:

- Individual configuration of the valve (see diagram)

d [mm]	DN [mm]	PN	kv-value ($\Delta p=1$ bar) [l/min]	EPDM Code	FPM Code	kg
16	10	10	70	199 231 202	199 231 212	1.200
20	15	10	185	199 231 203	199 231 213	0.774
25	20	10	350	199 231 204	199 231 214	1.300
32	25	10	700	199 231 205	199 231 215	0.919
40	32	10	1000	199 231 206	199 231 216	2.500
50	40	10	1600	199 231 207	199 231 217	1.701
63	50	10	3100	199 231 208	199 231 218	3.700
75	65	10	5000	199 231 209	199 231 219	5.400
90	80	10	7000	199 231 210	199 231 220	7.700
110	100	10	11000	199 231 211	199 231 221	10.800

d [mm]	D [mm]	H [mm]	H1 [mm]	H2 [mm]	H5 [mm]	L [mm]	L1 [mm]	L2 [mm]	L4 [mm]	L5 [mm]	L6 [mm]	L7 [mm]	z [mm]
16	50	159	27	62	77	93	194	56	25	261	76	48	66
20	50	159	27	62	77	95	194	56	25	261	76	48	67
25	58	168	30	71	77	108	194	65	25	261	76	48	77
32	68	168	36	71	77	118	194	71	25	261	76	48	83
40	84	202	44	84	99	137	224	85	45	305	95	59	99
50	97	202	51	84	99	147	224	89	45	305	95	59	105
63	124	225	64	106	99	168	224	101	45	305	95	59	117
75	166	257	85	156	66	233	144	136	70		60		167
90	200	274	105	168	70	254	152	141	70		65		180
110	238	273	123	175	78	301	169	164	120		72		215

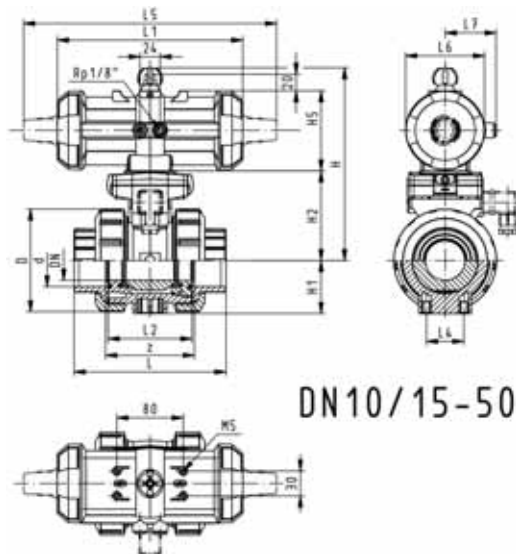

DN10/15-50

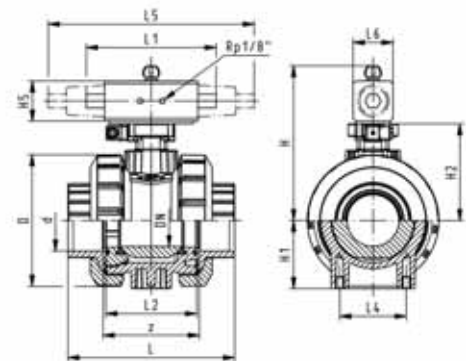

DN65-100



DN10/15 - 50



PROGEF Standard Ball valve type 231 DA (Double acting) Without manual override With socket fusion spigots metric

Model:

- Material: PP-H
- For easy installation and removal
- Integrated stainless steel mounting inserts
- Control time $90^\circ <$ 1-2 s
- Assignment of actuators: PA11 (DN10/15-25), PA21 (DN32-50), PA35 (DN65), PA40 (DN80), PA45 (DN100)

Option:

- Individual configuration of the valve (see diagram)

d [mm]	DN [mm]	PN	kv-value ($\Delta p=1$ bar) [l/min]	EPDM Code	FPM Code	kg
16	10	10	70	199 231 222	199 231 232	1.200
20	15	10	185	199 231 223	199 231 233	1.200
25	20	10	350	199 231 224	199 231 234	1.300
32	25	10	700	199 231 225	199 231 235	0.929
40	32	10	1000	199 231 226	199 231 236	2.500
50	40	10	1600	199 231 227	199 231 237	2.800
63	50	10	3100	199 231 228	199 231 238	3.700
75	65	10	5000	199 231 229	199 231 239	5.500
90	80	10	7000	199 231 230	199 231 240	7.800
110	100	10	11000	199 231 231	199 231 241	10.900

d [mm]	D [mm]	H [mm]	H1 [mm]	H2 [mm]	H5 [mm]	L [mm]	L1 [mm]	L2 [mm]	L3 [mm]	L4 [mm]	L5 [mm]	L6 [mm]	L7 [mm]
16	50	159	27	62	77	110	194	56	130	25	261	76	48
20	50	159	27	62	77	120	194	56	130	25	261	76	48
25	58	168	30	71	77	139	194	65	150	25	261	76	48
32	68	168	36	71	77	150	194	71	160	25	261	76	48
40	84	202	44	84	99	170	224	85	180	45	305	95	59
50	97	202	51	84	99	190	224	89	200	45	305	95	59
63	124	225	64	106	99	220	224	101	230	45	305	95	59
75	166	257	85	156	66	280	144	136	290	70		60	
90	200	274	105	168	70	296	152	141	310	70		65	
110	238	273	123	175	78	336	169	164	350	120		72	

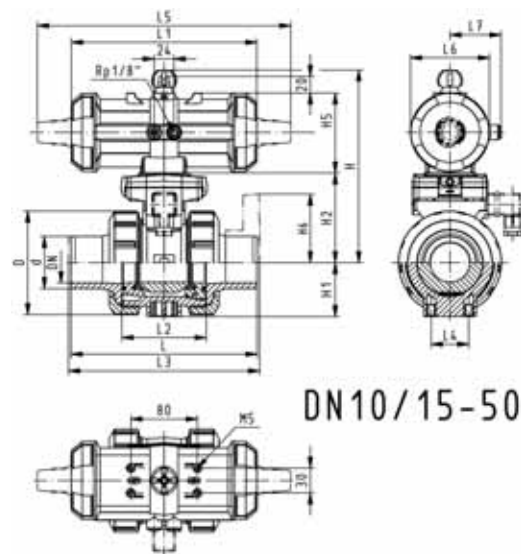

DN10/15-50

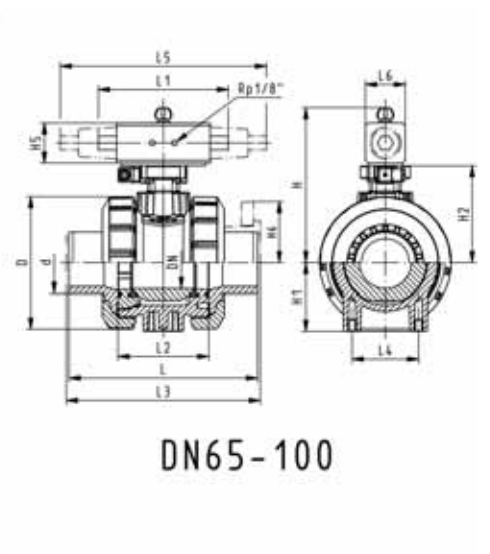

DN65-100



DN10/15 - 50

PROGEF Standard Ball valve type 231 DA (Double acting) Without manual override With fixed flanges PP-H serrated metric

Model:

- Material: PP-H
- For easy installation and removal
- Integrated stainless steel mounting inserts
- Control time $90^\circ <$ 1-2 s
- Built on with pneumatic actuator PA11 (DN10/15-25), PA21 (DN32-50)
- Overall length according to EN 558
- Connecting dimensions: ISO 7005 / EN 1092 / DIN 2501 PN10 / BS4504

Option:

- Individual configuration of the valve (see diagram)

d [mm]	DN [mm]	Inch	PN	kv-value ($\Delta p=1$ bar) [l/min]	EPDM Code	FPM Code	kg
20	15	½	10	185	199 231 463	199 231 473	1.400
25	20	¾	10	350	199 231 464	199 231 474	1.600
32	25	1	10	700	199 231 465	199 231 475	1.160
40	32	1 ¼	10	1000	199 231 466	199 231 476	3.100
50	40	1 ½	10	1600	199 231 467	199 231 477	3.600
63	50	2	10	3100	199 231 468	199 231 478	2.869

d [mm]	D [mm]	H [mm]	H1 [mm]	H2 [mm]	H4 [mm]	H5 [mm]	H6 [mm]	L [mm]	L1 [mm]	L2 [mm]	L3 [mm]	L4 [mm]	L5 [mm]	L6 [mm]	L7 [mm]
20	50	159	27	62	40	77	48	120	194	56	130	25	261	76	48
25	58	168	30	71	40	77	53	140	194	65	150	25	261	76	48
32	68	168	36	71	40	77	58	150	194	71	160	25	261	76	48
40	84	202	44	84	51	99	70	170	224	85	180	45	305	95	59
50	97	202	51	84	51	99	75	190	224	89	200	45	305	95	59
63	124	225	64	106	51	99	83	220	224	101	230	45	305	95	59

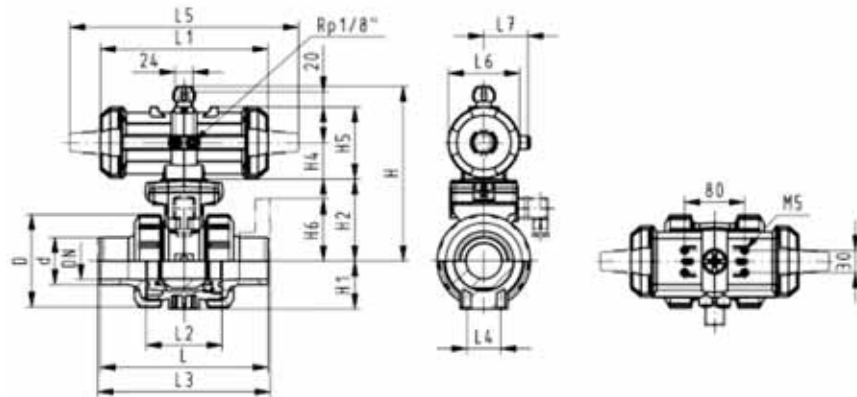



PROGEF Standard Ball valve type 231 DA (Double acting) Without manual override With backing flanges PP-st metric

Model:

- Material: PP-H
- For easy installation and removal
- Integrated stainless steel mounting inserts
- Control time $90^\circ <$ 1-2 s
- Assignment of actuators: PA11 (DN10/15-25), PA21 (DN32-50), PA35 (DN65), PA40 (DN80), PA45 (DN100)
- Overall length according to EN 558
- Connecting dimension: ISO 7005, EN 1092, BS 4504, DIN 2501

Option:

- Individual configuration of the valve (see diagram)

d [mm]	DN [mm]	Inch	PN	kv-value ($\Delta p=1$ bar) [l/min]	EPDM Code	FPM Code	kg
75	65	2 1/2	10	5000	199 231 369	199 231 379	9.700
90	80	3	10	7000	199 231 370	199 231 380	13.000
110	100	4	10	11000	199 231 371	199 231 381	18.000

d [mm]	D [mm]	H [mm]	H1 [mm]	H2 [mm]	H5 [mm]	H6 [mm]	L [mm]	L1 [mm]	L2 [mm]	L3 [mm]	L4 [mm]	L6 [mm]
75	166	257	85	156	66	93	280	144	136	290	70	60
90	200	274	105	168	70	100	296	152	141	310	70	65
110	238	273	123	175	78	110	336	169	164	350	120	72

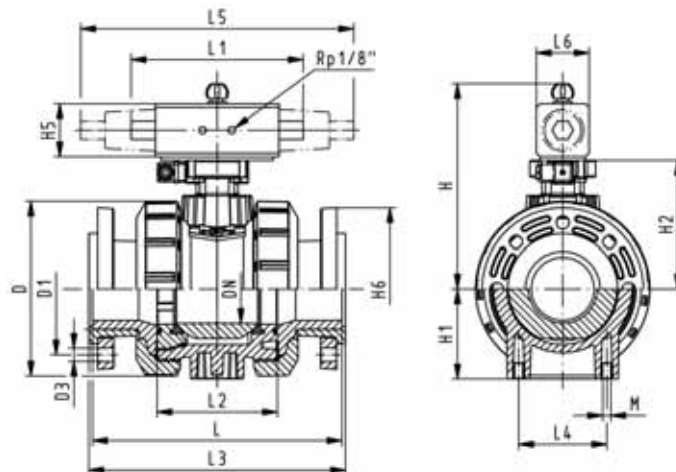



DN10/15 - 50



PROGEF Standard Ball valve type 231 DA (Double acting) Without manual override With butt fusion spigots IR-Plus SDR11 metric

Model:

- Material: PP-H
- For easy installation and removal
- Integrated stainless steel mounting inserts
- Control time $90^\circ <$ 1-2 s
- Assignment of actuators: PA11 (DN10/15-25), PA21 (DN32-50), PA35 (DN65), PA40 (DN80), PA45 (DN100)

Option:

- Individual configuration of the valve (see diagram)

d [mm]	DN [mm]	PN	kv-value ($\Delta p=1$ bar) [l/min]	EPDM Code	FPM Code	kg
20	15	10	185	199 231 873	199 231 883	1.200
25	20	10	350	199 231 874	199 231 884	1.300
32	25	10	700	199 231 875	199 231 885	1.400
40	32	10	1000	199 231 876	199 231 886	2.500
50	40	10	1600	199 231 877	199 231 887	2.800
63	50	10	3100	199 231 878	199 231 888	3.700
75	65	10	5000	199 231 879	199 231 889	5.500
90	80	10	7000	199 231 880	199 231 890	7.800
110	100	10	11000	199 231 881	199 231 891	10.900

d [mm]	D [mm]	H [mm]	H1 [mm]	H2 [mm]	H5 [mm]	L [mm]	L1 [mm]	L2 [mm]	L3 [mm]	L4 [mm]	L6 [mm]	e [mm]
20	50	159	27	62	77	130	194	56	130	25	76	1.9
25	58	168	30	71	77	143	194	65	150	25	76	2.3
32	68	168	36	71	77	150	194	71	160	25	76	3.0
40	84	202	44	84	99	171	224	85	180	45	95	3.7
50	97	202	51	84	99	191	224	89	200	45	95	4.6
63	124	225	64	106	99	220	224	101	230	45	95	5.8
75	166	257	85	156	66	266	144	136	290	70	60	8.2
90	200	274	105	168	70	264	152	141	310	70	65	9.9
110	238	273	123	175	78	301	169	164	350	120	72	12.0

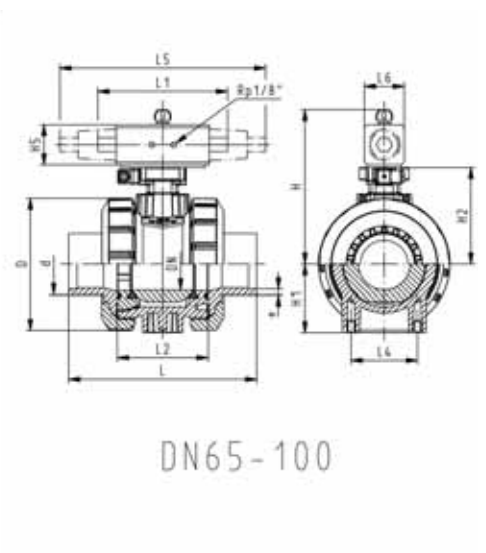
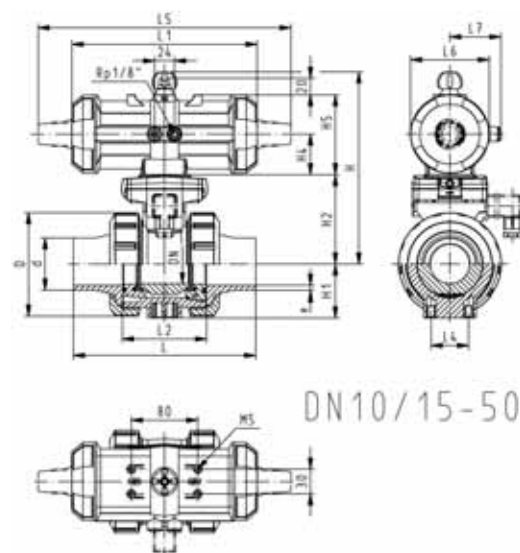



DN10/15 - 50



PROGEF Standard Ball valve type 231 DA (Double acting) Without manual override With butt fusion spigots SDR17.6 metric

Model:

- Material: PP-H
- For easy installation and removal
- Integrated stainless steel mounting inserts
- Control time 90° < 1-2 s
- Assignment of actuators: PA11 (DN10/15-25), PA21 (DN32-50), PA35 (DN65), PA40 (DN80), PA45 (DN100)

Option:

- Individual configuration of the valve (see diagram)

d [mm]	DN [mm]	PN	kv-value ($\Delta p=1$ bar) [l/min]	EPDM Code	FPM Code	kg
50	40	10	1600	199 231 977	199 231 987	5.500
63	50	10	3100	199 231 978	199 231 988	
75	65	10	5000	199 231 979	199 231 989	
90	80	10	7000	199 231 980	199 231 990	
110	100	10	11000	199 231 981	199 231 991	

d [mm]	D [mm]	H [mm]	H1 [mm]	H2 [mm]	H5 [mm]	L [mm]	L1 [mm]	L2 [mm]	L3 [mm]	L4 [mm]	L6 [mm]	e [mm]
50	97	202	51	84	99	191	224	89	200	45	95	2.9
63	124	225	64	106	99	220	224	101	230	45	95	3.6
75	166	257	85	156	66	266	144	136	290	70	60	4.6
90	200	274	105	168	70	264	152	141	310	70	65	5.5
110	238	273	123	175	78	301	169	164	350	120	72	6.7

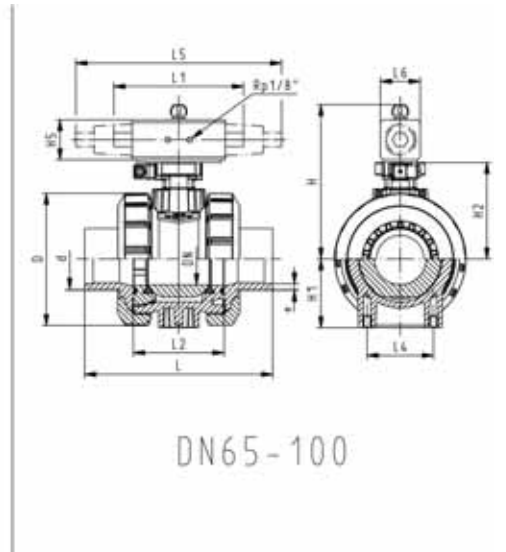
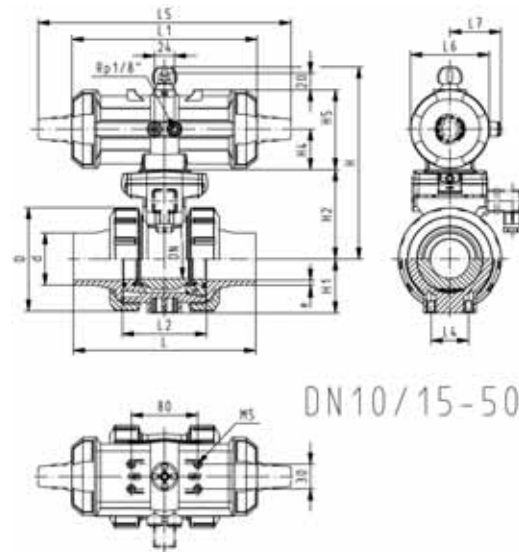



PROGEF Standard 3-Way ball valve type 286 Horizontal/L-port Without manual override With fusion sockets metric

Model:

- Material: PP-H
- Built on with pneumatic actuator PA11 (DN10/15-25), PA21 (DN32-50)
- Actuator fails safe to the basic position
- Basic position B-C opened, activated position A-C opened, see flow scheme
- Control time $90^\circ <$ 1-3 s
- For easy installation and removal
- Integrated stainless steel mounting inserts

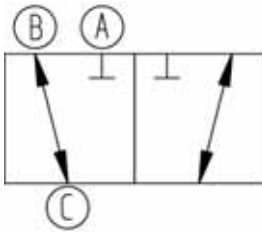
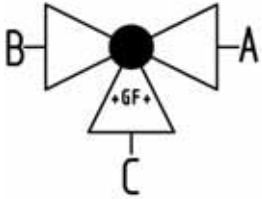

d [mm]	DN [mm]	PN	kv-value ($\Delta p=1$ bar) [l/min]	EPDM Code	FPM Code	kg
16	10	10	50	199 286 022	199 286 032	1.031
20	15	10	75	199 286 023	199 286 033	1.035
25	20	10	150	199 286 024	199 286 034	1.125
32	25	10	280	199 286 025	199 286 035	1.250
40	32	10	480	199 286 026	199 286 036	2.217
50	40	10	620	199 286 027	199 286 037	2.513
63	50	10	1230	199 286 028	199 286 038	3.500

d [mm]	D [mm]	H [mm]	H1 [mm]	H2 [mm]	H3 [mm]	H4 [mm]	H5 [mm]	H6 [mm]	L [mm]	L1 [mm]	L2 [mm]	L3 [mm]	L4 [mm]	L5 [mm]	L6 [mm]
16	50	159	28	62	97	40	77	8	110	194	72	36	25	261	76
20	50	159	28	62	97	40	77	8	112	194	72	36	25	261	76
25	58	168	32	71	97	40	77	8	129	194	85	43	25	261	76
32	68	168	36	71	97	40	77	8	146	194	98	49	25	261	76
40	84	203	45	84	119	51	99	9	170	224	118	59	45	305	95
50	97	203	51	84	119	51	99	9	193	224	135	68	45	305	95
63	124	225	65	106	119	51	99	9	244	224	176	88	45	305	95

d [mm]	L7 [mm]	M	z [mm]	z1 [mm]
16	48	6	82	41
20	48	6	82	41
25	48	6	97	49
32	48	6	110	55
40	59	8	132	66
50	59	8	151	76
63	59	8	188	94

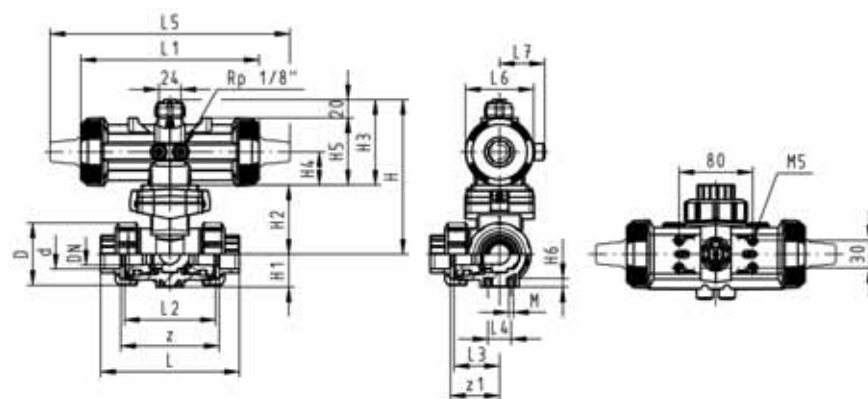



PROGEF Standard 3-Way ball valve type 286 Horizontal/L-port Without manual override With threaded sockets reinforced Rp

Model:

- Material: PP-H
- Built on with pneumatic actuator PA11 (DN10/15-25), PA21 (DN32-50)
- Actuator fails safe to the basic position
- Basic position B-C opened, activated position A-C opened, see flow scheme
- Control time $90^\circ <$) 1-3 s
- For easy installation and removal
- Integrated stainless steel mounting inserts

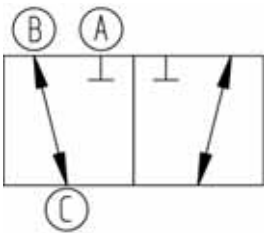
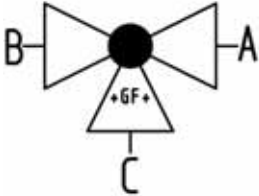

Rp [inch]	DN [mm]	PN	kv-value ($\Delta p=1$ bar) [l/min]	EPDM Code	FPM Code	kg
3/8	10	10	50	199 286 122	199 286 132	1.031
1/2	15	10	75	199 286 123	199 286 133	1.035
3/4	20	10	150	199 286 124	199 286 134	1.125
1	25	10	280	199 286 125	199 286 135	1.250
1 1/4	32	10	480	199 286 126	199 286 136	2.217
1 1/2	40	10	620	199 286 127	199 286 137	2.513
2	50	10	1230	199 286 128	199 286 138	3.420

Rp [inch]	D [mm]	H [mm]	H1 [mm]	H2 [mm]	H3 [mm]	H4 [mm]	H5 [mm]	H6 [mm]	L [mm]	L1 [mm]	L2 [mm]	L3 [mm]	L4 [mm]	L5 [mm]	L6 [mm]
3/8	50	159	28	62	97	40	77	8	112	194	72	36	25	261	76
1/2	50	159	28	62	97	40	77	8	114	194	72	36	25	261	76
3/4	58	168	32	71	97	40	77	8	131	194	85	43	25	261	76
1	68	168	36	71	97	40	77	8	154	194	98	49	25	261	76
1 1/4	84	203	45	84	119	51	99	9	180	224	118	59	45	305	95
1 1/2	97	203	51	84	119	51	99	9	203	224	135	68	45	305	95
2	124	225	65	106	119	51	99	9	258	224	176	88	45	305	95

Rp [inch]	L7 [mm]	M	z [mm]	z1 [mm]
3/8	48	6	86	43
1/2	48	6	84	42
3/4	48	6	99	50
1	48	6	112	56
1 1/4	59	8	132	66
1 1/2	59	8	153	77
2	59	8	196	98

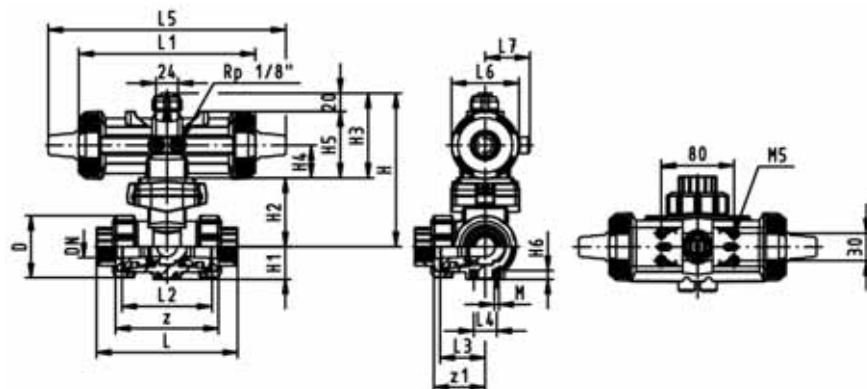



PROGEF Standard 3-Way ball valve type 286 Horizontal/L-port Without manual override With socket fusion spigots metric

Model:

- Material: PP-H
- Built on with pneumatic actuator PA11 (DN10/15-25), PA21 (DN32-50)
- Actuator fails safe to the basic position
- Basic position B-C opened, activated position A-C opened, see flow scheme
- Control time 90°<) 1-3 s
- For easy installation and removal
- Integrated stainless steel mounting inserts

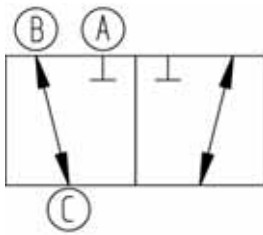
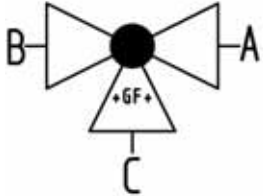

d [mm]	DN [mm]	PN	kv-value ($\Delta p=1$ bar) [l/min]	EPDM Code	FPM Code	kg
16	10	10	50	199 286 002	199 286 012	1.035
20	15	10	75	199 286 003	199 286 013	1.041
25	20	10	150	199 286 004	199 286 014	1.135
32	25	10	280	199 286 005	199 286 015	1.265
40	32	10	480	199 286 006	199 286 016	2.231
50	40	10	620	199 286 007	199 286 017	2.554
63	50	10	1230	199 286 008	199 286 018	3.502

d [mm]	D [mm]	H [mm]	H1 [mm]	H2 [mm]	H3 [mm]	H4 [mm]	H5 [mm]	H6 [mm]	L [mm]	L1 [mm]	L2 [mm]	L3 [mm]	L4 [mm]	L5 [mm]	L6 [mm]
16	50	159	28	62	97	40	77	8	126	194	72	36	25	261	76
20	50	159	28	62	97	40	77	8	136	194	72	36	25	261	76
25	58	168	32	71	97	40	77	8	159	194	85	43	25	261	76
32	68	168	36	71	97	40	77	8	178	194	98	49	25	261	76
40	84	203	45	84	119	51	99	9	204	224	118	59	45	305	95
50	97	203	51	84	119	51	99	9	237	224	135	68	45	305	95
63	124	225	65	106	119	51	99	9	296	224	176	88	45	305	95

d [mm]	L7 [mm]	M
16	48	6
20	48	6
25	48	6
32	48	6
40	59	8
50	59	8
63	59	8

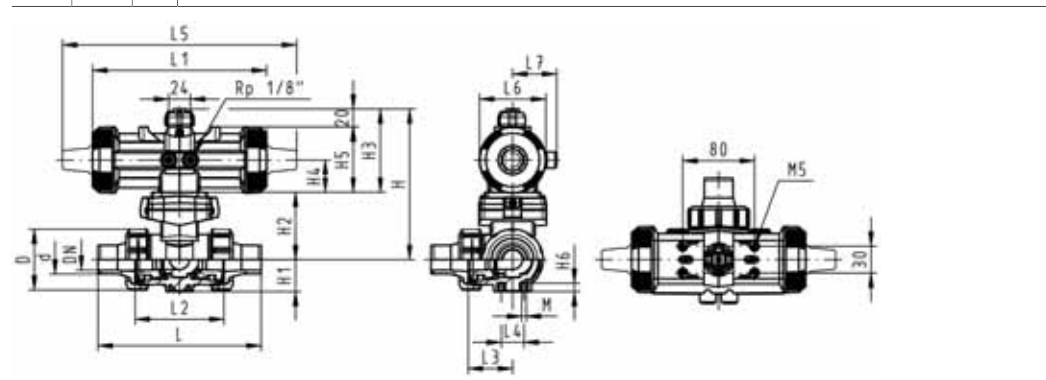



**PROGEF Standard
3-Way ball valve type 286
Horizontal/L-port
Without manual override
With butt fusion spigots
IR-Plus SDR11 metric**

Model:

- Material: PP-H
- Built on with pneumatic actuator PA11 (DN10/15-25), PA21 (DN32-50)
- Actuator fails safe to the basic position
- Basic position B-C opened, activated position A-C opened, see flow scheme
- Control time $90^\circ <$ 1-3 s
- For easy installation and removal
- Integrated stainless steel mounting inserts

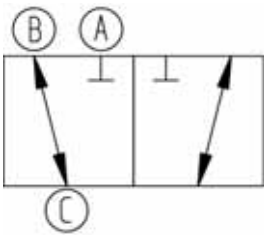
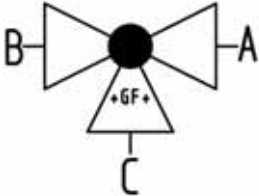

d [mm]	DN [mm]	PN	kv-value ($\Delta p=1$ bar) [l/min]	EPDM Code	FPM Code	kg
20	15	10	75	199 286 083	199 286 093	1.050
25	20	10	150	199 286 084	199 286 094	1.138
32	25	10	280	199 286 085	199 286 095	1.265
40	32	10	480	199 286 086	199 286 096	2.231
50	40	10	620	199 286 087	199 286 097	2.554
63	50	10	1230	199 286 088	199 286 098	3.568

d [mm]	D [mm]	H [mm]	H1 [mm]	H2 [mm]	H3 [mm]	H4 [mm]	H5 [mm]	H6 [mm]	L [mm]	L1 [mm]	L2 [mm]	L3 [mm]	L4 [mm]	L5 [mm]	L6 [mm]
20	50	159	28	62	97	40	77	8	146	194	72	36	25	261	76
25	58	168	32	71	97	40	77	8	163	194	85	43	25	261	76
32	68	168	36	71	97	40	77	8	178	194	98	49	25	261	76
40	84	203	45	84	119	51	99	9	204	224	118	59	45	305	95
50	97	203	51	84	119	51	99	9	237	224	135	68	45	305	95
63	124	225	65	106	119	51	99	9	296	224	176	88	45	305	95

d [mm]	L7 [mm]	M
20	48	6
25	48	6
32	48	6
40	59	8
50	59	8
63	59	8

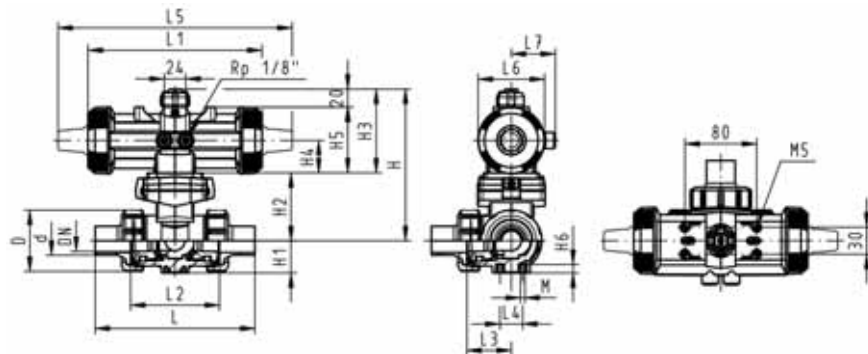



PROGEF Standard

3-Way ball valve type 286

Horizontal/L-port DA (Double acting)

Without manual override

With fusion sockets metric

Model:

- Material: PP-H
- Built on with pneumatic actuator PA11 (DN10/15-25), PA21 (DN32-50)
- Basic position A-C opened, activated position B-C opened, see flow scheme
- Control time $90^\circ <$ 1-3 s
- For easy installation and removal
- Integrated stainless steel mounting inserts

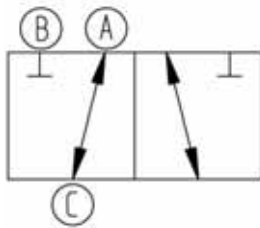
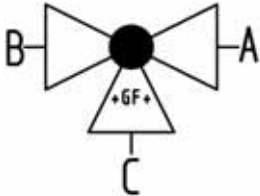

d [mm]	DN [mm]	PN	kv-value ($\Delta p=1$ bar) [l/min]	EPDM Code	FPM Code	kg
16	10	10	50	199 286 182	199 286 192	0.841
20	15	10	75	199 286 183	199 286 193	0.845
25	20	10	150	199 286 184	199 286 194	0.935
32	25	10	280	199 286 185	199 286 195	1.060
40	32	10	480	199 286 186	199 286 196	1.793
50	40	10	620	199 286 187	199 286 197	2.089
63	50	10	1230	199 286 188	199 286 198	2.996

d [mm]	D [mm]	H [mm]	H1 [mm]	H2 [mm]	H3 [mm]	H4 [mm]	H5 [mm]	H6 [mm]	L [mm]	L1 [mm]	L2 [mm]	L3 [mm]	L4 [mm]	L5 [mm]	L6 [mm]
16	50	159	28	62	97	40	77	8	110	194	72	36	25	261	76
20	50	159	28	62	97	40	77	8	112	194	72	36	25	261	76
25	58	168	32	71	97	40	77	8	129	194	85	43	25	261	76
32	68	168	36	71	97	40	77	8	146	194	98	49	25	261	76
40	84	203	45	84	119	51	99	9	170	224	118	59	45	305	95
50	97	203	51	84	119	51	99	9	193	224	135	68	45	305	95
63	124	225	65	106	119	51	99	9	244	224	176	88	45	305	95

d [mm]	L7 [mm]	M	z [mm]	z1 [mm]
16	48	6	82	41
20	48	6	82	41
25	48	6	97	49
32	48	6	110	55
40	59	8	132	66
50	59	8	151	76
63	59	8	188	94

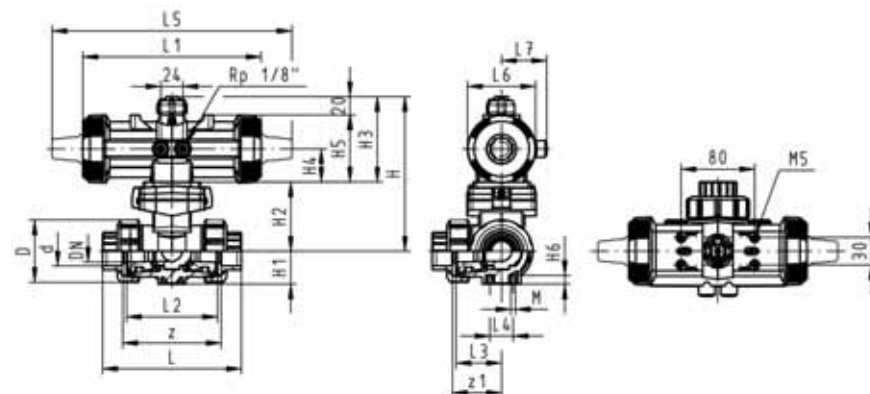



PROGEF Standard
3-Way ball valve type 286
Horizontal/L-port DA (Double acting)
Without manual override
With threaded sockets reinforced Rp

Model:

- Material: PP-H
- Built on with pneumatic actuator PA11 (DN10/15-25), PA21 (DN32-50)
- Basic position A-C opened, activated position B-C opened, see flow scheme
- Control time $90^\circ <$) 1-3 s
- For easy installation and removal
- Integrated stainless steel mounting inserts

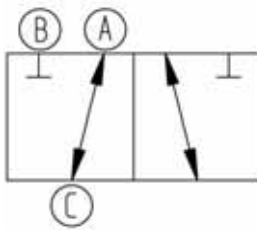
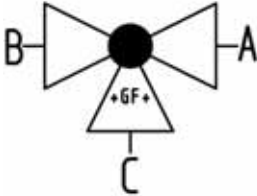

Rp [inch]	DN [mm]	PN	kv-value ($\Delta p=1$ bar) [l/min]	EPDM Code	FPM Code	kg
3/8	10	10	50	199 286 282	199 286 292	0.841
1/2	15	10	75	199 286 283	199 286 293	0.845
3/4	20	10	150	199 286 284	199 286 294	0.935
1	25	10	280	199 286 285	199 286 295	1.060
1 1/4	32	10	480	199 286 286	199 286 296	1.793
1 1/2	40	10	620	199 286 287	199 286 297	2.156
2	50	10	1230	199 286 288	199 286 298	2.996

Rp [inch]	D [mm]	H [mm]	H1 [mm]	H2 [mm]	H3 [mm]	H4 [mm]	H5 [mm]	H6 [mm]	L [mm]	L1 [mm]	L2 [mm]	L3 [mm]	L4 [mm]	L5 [mm]	L6 [mm]
3/8	50	159	28	62	97	40	77	8	112	194	72	36	25	261	76
1/2	50	159	28	62	97	40	77	8	114	194	72	36	25	261	76
3/4	58	168	32	71	97	40	77	8	131	194	85	43	25	261	76
1	68	168	36	71	97	40	77	8	154	194	98	49	25	261	76
1 1/4	84	203	45	84	119	51	99	9	180	224	118	59	45	305	95
1 1/2	97	203	51	84	119	51	99	9	203	224	135	68	45	305	95
2	124	225	65	106	119	51	99	9	258	224	176	88	45	305	95

Rp [inch]	L7 [mm]	M	z [mm]	z1 [mm]
3/8	48	6	86	43
1/2	48	6	84	42
3/4	48	6	99	50
1	48	6	112	56
1 1/4	59	8	132	66
1 1/2	59	8	153	77
2	59	8	196	98

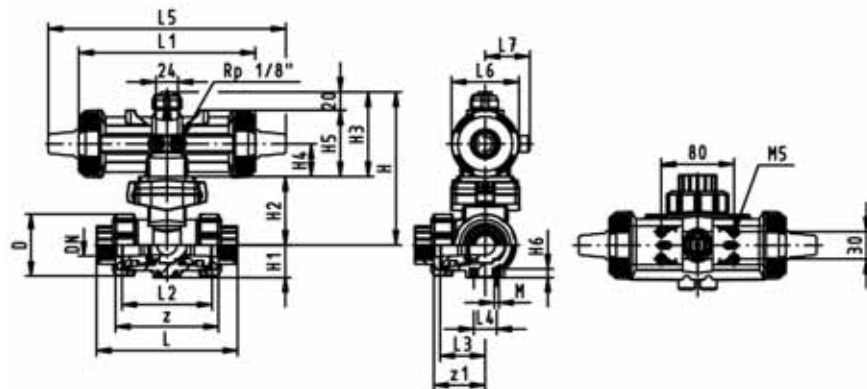



PROGEF Standard
3-Way ball valve type 286
Horizontal/L-port DA (Double acting)
Without manual override
With socket fusion spigots metric

Model:

- Material: PP-H
- Built on with pneumatic actuator PA11 (DN10/15-25), PA21 (DN32-50)
- Basic position A-C opened, activated position B-C opened, see flow scheme
- Control time $90^\circ <$ 1-3 s
- For easy installation and removal
- Integrated stainless steel mounting inserts

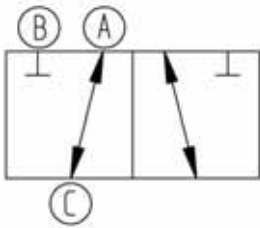
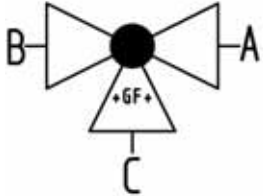

d [mm]	DN [mm]	PN	kv-value ($\Delta p=1$ bar) [l/min]	EPDM Code	FPM Code	kg
16	10	10	50	199 286 162	199 286 172	0.845
20	15	10	75	199 286 163	199 286 173	0.851
25	20	10	150	199 286 164	199 286 174	0.945
32	25	10	280	199 286 165	199 286 175	1.075
40	32	10	480	199 286 166	199 286 176	1.807
50	40	10	620	199 286 167	199 286 177	2.130
63	50	10	1230	199 286 168	199 286 178	3.078

d [mm]	D [mm]	H [mm]	H1 [mm]	H2 [mm]	H3 [mm]	H4 [mm]	H5 [mm]	H6 [mm]	L [mm]	L1 [mm]	L2 [mm]	L3 [mm]	L4 [mm]	L5 [mm]	L6 [mm]
16	50	159	28	62	97	40	77	8	126	194	72	36	25	261	76
20	50	159	28	62	97	40	77	8	136	194	72	36	25	261	76
25	58	168	32	71	97	40	77	8	159	194	85	43	25	261	76
32	68	168	36	71	97	40	77	8	178	194	98	49	25	261	76
40	84	203	45	84	119	51	99	9	204	224	118	59	45	305	95
50	97	203	51	84	119	51	99	9	237	224	135	68	45	305	95
63	124	225	65	106	119	51	99	9	296	224	176	88	45	305	95

d [mm]	L7 [mm]	M
16	48	6
20	48	6
25	48	6
32	48	6
40	59	8
50	59	8
63	59	8

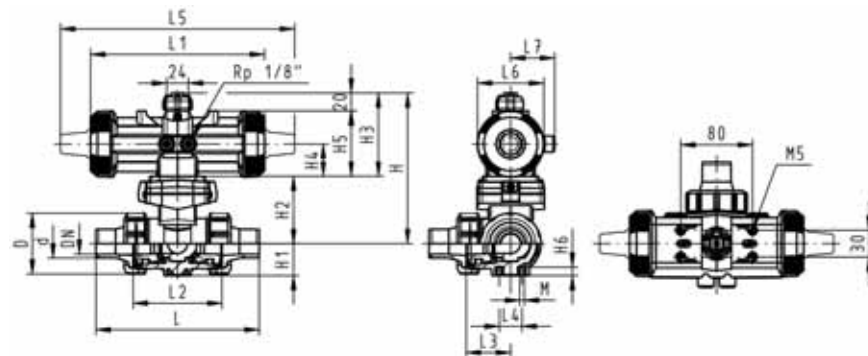



PROGEF Standard
3-Way ball valve type 286
Horizontal/L-port DA (Double acting)
Without manual override
With butt fusion spigots
IR-Plus SDR11 metric

Model:

- Material: PP-H
- Built on with pneumatic actuator PA11 (DN10/15-25), PA21 (DN32-50)
- Basic position A-C opened, activated position B-C opened, see flow scheme
- Control time 90°<) 1-3 s
- For easy installation and removal
- Integrated stainless steel mounting inserts

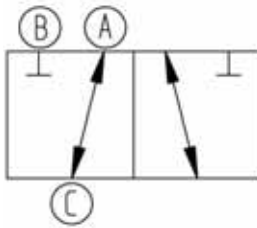
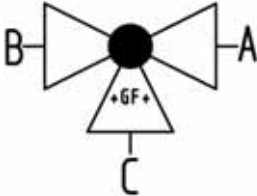

d [mm]	DN [mm]	PN	kv-value ($\Delta p=1$ bar) [l/min]	EPDM Code	FPM Code	kg
20	15	10	75	199 286 243	199 286 253	0.851
25	20	10	150	199 286 244	199 286 254	0.945
32	25	10	280	199 286 245	199 286 255	1.075
40	32	10	480	199 286 246	199 286 256	1.807
50	40	10	620	199 286 247	199 286 257	2.130
63	50	10	1230	199 286 248	199 286 258	3.082

d [mm]	D [mm]	H [mm]	H1 [mm]	H2 [mm]	H3 [mm]	H4 [mm]	H5 [mm]	H6 [mm]	L [mm]	L1 [mm]	L2 [mm]	L3 [mm]	L4 [mm]	L5 [mm]	L6 [mm]
20	50	159	28	62	97	40	77	8	146	194	72	36	25	261	76
25	58	168	32	71	97	40	77	8	163	194	85	43	25	261	76
32	68	168	36	71	97	40	77	8	178	194	98	49	25	261	76
40	84	203	45	84	119	51	99	9	204	224	118	59	45	305	95
50	97	203	51	84	119	51	99	9	237	224	135	68	45	305	95
63	124	225	65	106	119	51	99	9	296	224	176	88	45	305	95

d [mm]	L7 [mm]	M
20	48	6
25	48	6
32	48	6
40	59	8
50	59	8
63	59	8

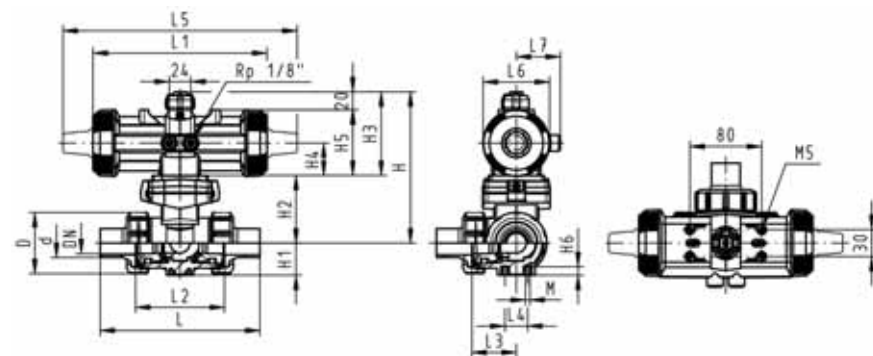



PROGEF Standard 3-Way ball valve type 286 Horizontal/T-port Without manual override With fusion sockets metric

Model:

- Material: PP-H
- Built on with pneumatic actuator PA11 (DN10/15-25), PA21 (DN32-50)
- Actuator fails safe to the basic position
- Basic position B-C opened, activated position A-B-C opened, see flow scheme
- Control time 90°<) 1-3 s
- For easy installation and removal
- Integrated stainless steel mounting inserts

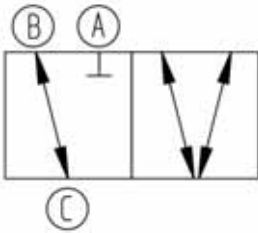
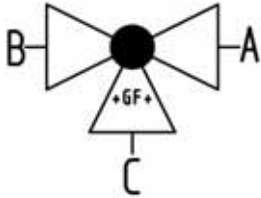

d [mm]	DN [mm]	PN	kv-value ($\Delta p=1$ bar) [l/min]	EPDM Code	FPM Code	kg
16	10	10	140	199 286 062	199 286 072	1.031
20	15	10	200	199 286 063	199 286 073	1.035
25	20	10	470	199 286 064	199 286 074	1.124
32	25	10	793	199 286 065	199 286 075	1.266
40	32	10	1290	199 286 066	199 286 076	2.210
50	40	10	1910	199 286 067	199 286 077	2.499
63	50	10	3100	199 286 068	199 286 078	3.391

d [mm]	D [mm]	H [mm]	H1 [mm]	H2 [mm]	H3 [mm]	H4 [mm]	H5 [mm]	H6 [mm]	L [mm]	L1 [mm]	L2 [mm]	L3 [mm]	L4 [mm]	L5 [mm]	L6 [mm]
16	50	159	28	62	97	40	77	8	110	194	72	36	25	261	76
20	50	159	28	62	97	40	77	8	112	194	72	36	25	261	76
25	58	168	32	71	97	40	77	8	129	194	85	43	25	261	76
32	68	168	36	71	97	40	77	8	146	194	98	49	25	261	76
40	84	203	45	84	119	51	99	9	170	224	118	59	45	305	95
50	97	203	51	84	119	51	99	9	193	224	135	68	45	305	95
63	124	225	65	106	119	51	99	9	244	224	176	88	45	305	95

d [mm]	L7 [mm]	M	z [mm]	z1 [mm]
16	48	6	82	41
20	48	6	82	41
25	48	6	97	49
32	48	6	110	55
40	59	8	132	66
50	59	8	151	76
63	59	8	188	94

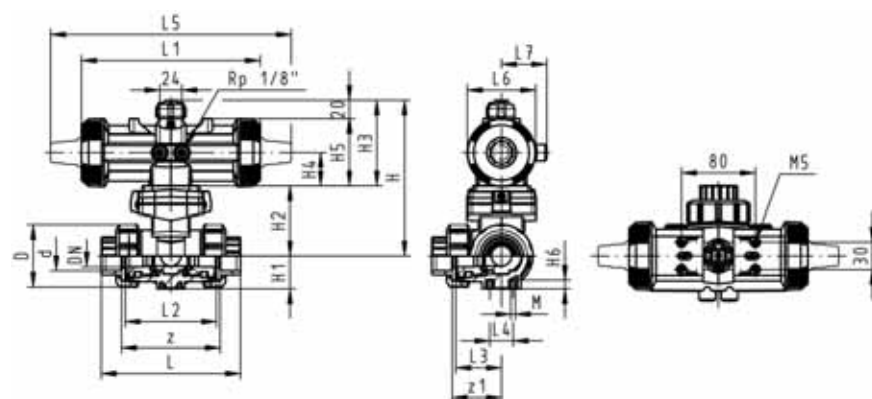



PROGEF Standard 3-Way ball valve type 286 Horizontal/T-port Without manual override With threaded sockets reinforced Rp

Model:

- Material: PP-H
- Built on with pneumatic actuator PA11 (DN10/15-25), PA21 (DN32-50)
- Actuator fails safe to the basic position
- Basic position B-C opened, activated position A-B-C opened, see flow scheme
- Control time $90^\circ <$) 1-3 s
- For easy installation and removal
- Integrated stainless steel mounting inserts

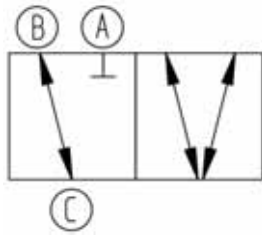
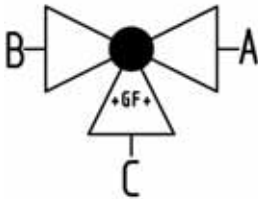

Rp [inch]	DN [mm]	PN	kv-value ($\Delta p=1$ bar) [l/min]	EPDM Code	FPM Code	kg
3/8	10	10	140	199 286 142	199 286 152	1.031
1/2	15	10	200	199 286 143	199 286 153	1.035
3/4	20	10	470	199 286 144	199 286 154	1.124
1	25	10	793	199 286 145	199 286 155	1.245
1 1/4	32	10	1290	199 286 146	199 286 156	2.210
1 1/2	40	10	1910	199 286 147	199 286 157	2.499
2	50	10	3100	199 286 148	199 286 158	3.391

Rp [inch]	D [mm]	H [mm]	H1 [mm]	H2 [mm]	H3 [mm]	H4 [mm]	H5 [mm]	H6 [mm]	L [mm]	L1 [mm]	L2 [mm]	L3 [mm]	L4 [mm]	L5 [mm]	L6 [mm]
3/8	50	159	28	62	97	40	77	8	112	194	72	36	25	261	76
1/2	50	159	28	62	97	40	77	8	114	194	72	36	25	261	76
3/4	58	168	32	71	97	40	77	8	131	194	85	43	25	261	76
1	68	168	36	71	97	40	77	8	154	194	98	49	25	261	76
1 1/4	84	203	45	84	119	51	99	9	180	224	118	59	45	305	95
1 1/2	97	203	51	84	119	51	99	9	203	224	135	68	45	305	95
2	124	225	65	106	119	51	99	9	258	224	176	88	45	305	95

Rp [inch]	L7 [mm]	M	z [mm]	z1 [mm]
3/8	48	6	86	43
1/2	48	6	84	42
3/4	48	6	99	50
1	48	6	112	56
1 1/4	59	8	132	66
1 1/2	59	8	153	77
2	59	8	196	98

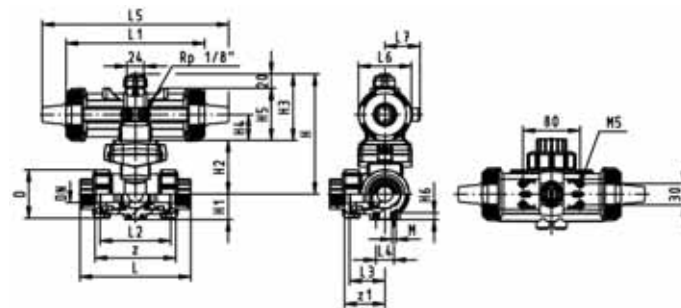



PROGEF Standard 3-Way ball valve type 286 Horizontal/T-port Without manual override With socket fusion spigots metric

Model:

- Material: PP-H
- Built on with pneumatic actuator PA11 (DN10/15-25), PA21 (DN32-50)
- Actuator fails safe to the basic position
- Basic position B-C opened, activated position A-B-C opened, see flow scheme
- Control time $90^\circ <$ 1-3 s
- For easy installation and removal
- Integrated stainless steel mounting inserts

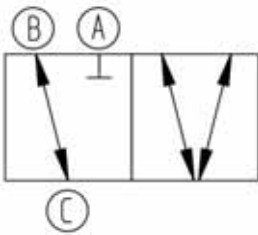
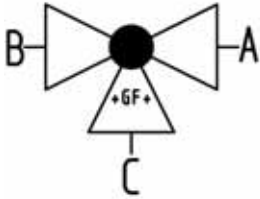

d [mm]	DN [mm]	PN	kv-value ($\Delta p=1$ bar) [l/min]	EPDM Code	FPM Code	kg
16	10	10	140	199 286 042	199 286 052	1.035
20	15	10	200	199 286 043	199 286 053	1.041
25	20	10	470	199 286 044	199 286 054	1.134
32	25	10	793	199 286 045	199 286 055	1.261
40	32	10	1290	199 286 046	199 286 056	2.224
50	40	10	1910	199 286 047	199 286 057	2.541
63	50	10	3100	199 286 048	199 286 058	3.473

d [mm]	D [mm]	H [mm]	H1 [mm]	H2 [mm]	H3 [mm]	H4 [mm]	H5 [mm]	H6 [mm]	L [mm]	L1 [mm]	L2 [mm]	L3 [mm]	L4 [mm]	L5 [mm]	L6 [mm]
16	50	159	28	62	97	40	77	8	126	194	72	36	25	261	76
20	50	159	28	62	97	40	77	8	136	194	72	36	25	261	76
25	58	168	32	71	97	40	77	8	159	194	85	43	25	261	76
32	68	168	36	71	97	40	77	8	178	194	98	49	25	261	76
40	84	203	45	84	119	51	99	9	204	224	118	59	45	305	95
50	97	203	51	84	119	51	99	9	237	224	135	68	45	305	95
63	124	225	65	106	119	51	99	9	296	224	176	88	45	305	95

d [mm]	L7 [mm]	M
16	48	6
20	48	6
25	48	6
32	48	6
40	59	8
50	59	8
63	59	8

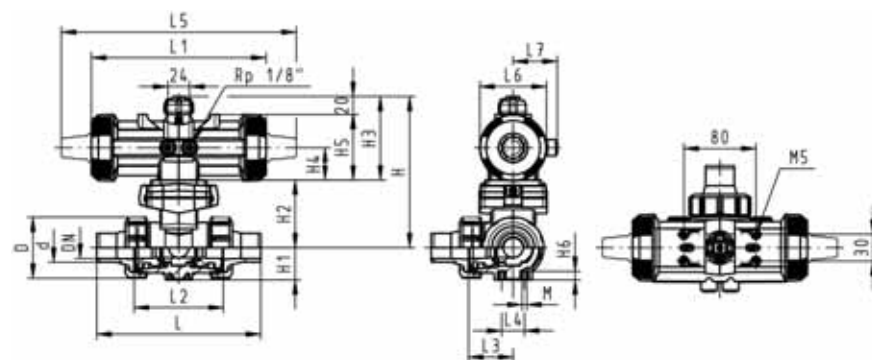



PROGEF Standard 3-Way ball valve type 286 Horizontal/T-port DA (Double acting) Without manual override With fusion sockets metric

Model:

- Material: PP-H
- Built on with pneumatic actuator PA11 (DN10/15-25), PA21 (DN32-50)
- Basic position A-B-C opened, activated position B-C opened, see flow scheme
- Control time $90^\circ <$ 1-3 s
- For easy installation and removal
- Integrated stainless steel mounting inserts

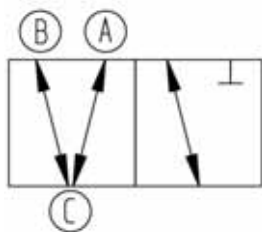
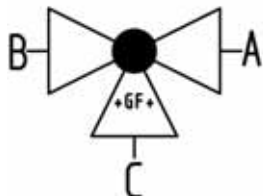

d [mm]	DN [mm]	PN	kv-value ($\Delta p=1$ bar) [l/min]	EPDM Code	FPM Code	kg
16	10	10	140	199 286 222	199 286 232	0.840
20	15	10	200	199 286 223	199 286 233	0.844
25	20	10	470	199 286 224	199 286 234	0.934
32	25	10	793	199 286 225	199 286 235	1.055
40	32	10	1290	199 286 226	199 286 236	1.786
50	40	10	1910	199 286 227	199 286 237	2.075
63	50	10	3100	199 286 228	199 286 238	2.967

d [mm]	D [mm]	H [mm]	H1 [mm]	H2 [mm]	H3 [mm]	H4 [mm]	H5 [mm]	H6 [mm]	L [mm]	L1 [mm]	L2 [mm]	L3 [mm]	L4 [mm]	L5 [mm]	L6 [mm]
16	50	159	28	62	97	40	77	8	110	194	72	36	25	261	76
20	50	159	28	62	97	40	77	8	112	194	72	36	25	261	76
25	58	168	32	71	97	40	77	8	129	194	85	43	25	261	76
32	68	168	36	71	97	40	77	8	146	194	98	49	25	261	76
40	84	203	45	84	119	51	99	9	170	224	118	59	45	305	95
50	97	203	51	84	119	51	99	9	193	224	135	68	45	305	95
63	124	225	65	106	119	51	99	9	244	224	176	88	45	305	95

d [mm]	L7 [mm]	M	z [mm]	z1 [mm]
16	48	6	82	41
20	48	6	82	41
25	48	6	97	49
32	48	6	110	55
40	59	8	132	66
50	59	8	151	76
63	59	8	188	94

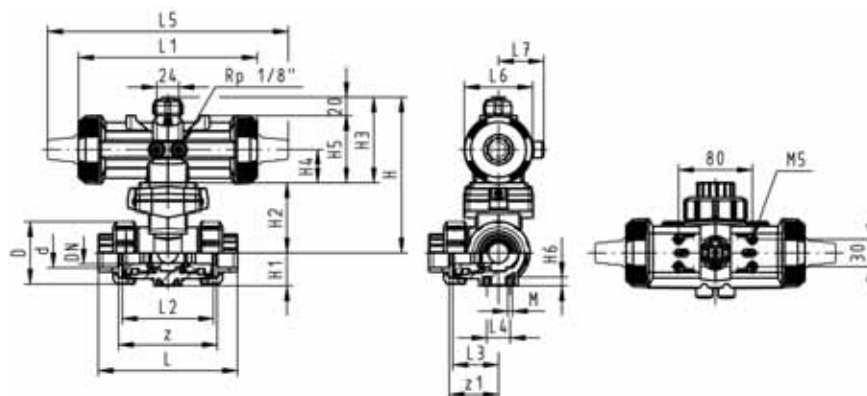



PROGEF Standard
3-Way ball valve type 286
Horizontal/T-port DA (Double acting)
Without manual override
With threaded sockets reinforced Rp

Model:

- Material: PP-H
- Built on with pneumatic actuator PA11 (DN10/15-25), PA21 (DN32-50)
- Basic position A-B-C opened, activated position B-C opened, see flow scheme
- Control time $90^\circ <$) 1-3 s
- For easy installation and removal
- Integrated stainless steel mounting inserts

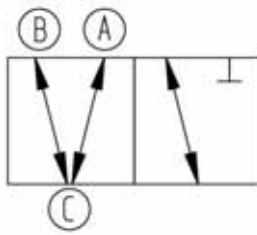
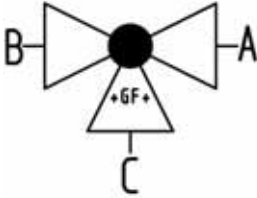

Rp [inch]	DN [mm]	PN	kv-value ($\Delta p=1$ bar) [l/min]	EPDM Code	FPM Code	kg
3/8	10	10	140	199 286 302	199 286 312	0.840
1/2	15	10	200	199 286 303	199 286 313	0.844
3/4	20	10	470	199 286 304	199 286 314	0.934
1	25	10	793	199 286 305	199 286 315	1.055
1 1/4	32	10	1290	199 286 306	199 286 316	1.786
1 1/2	40	10	1910	199 286 307	199 286 317	2.075
2	50	10	3100	199 286 308	199 286 318	2.967

Rp [inch]	D [mm]	H [mm]	H1 [mm]	H2 [mm]	H3 [mm]	H4 [mm]	H5 [mm]	H6 [mm]	L [mm]	L1 [mm]	L2 [mm]	L3 [mm]	L4 [mm]	L5 [mm]	L6 [mm]
3/8	50	159	28	62	97	40	77	8	112	194	72	36	25	261	76
1/2	50	159	28	62	97	40	77	8	114	194	72	36	25	261	76
3/4	58	168	32	71	97	40	77	8	131	194	85	43	25	261	76
1	68	168	36	71	97	40	77	8	154	194	98	49	25	261	76
1 1/4	84	203	45	84	119	51	99	9	180	224	118	59	45	305	95
1 1/2	97	203	51	84	119	51	99	9	203	224	135	68	45	305	95
2	124	225	65	106	119	51	99	9	258	224	176	88	45	305	95

Rp [inch]	L7 [mm]	M	z [mm]	z1 [mm]
3/8	48	6	86	43
1/2	48	6	84	42
3/4	48	6	99	50
1	48	6	112	56
1 1/4	59	8	132	66
1 1/2	59	8	153	77
2	59	8	196	98

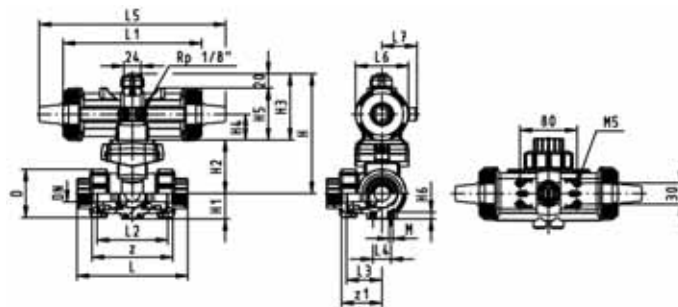



PROGEF Standard
3-Way ball valve type 286
Horizontal/T-port DA (Double acting)
Without manual override
With socket fusion spigots metric

Model:

- Material: PP-H
- Built on with pneumatic actuator PA11 (DN10/15-25), PA21 (DN32-50)
- Basic position A-B-C opened, activated position B-C opened, see flow scheme
- Control time 90°< 1-3 s
- For easy installation and removal
- Integrated stainless steel mounting inserts

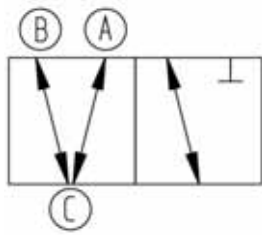
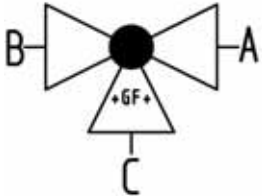

d [mm]	DN [mm]	PN	kv-value ($\Delta p=1$ bar) [l/min]	EPDM Code	FPM Code	kg
16	10	10	140	199 286 202	199 286 212	0.844
20	15	10	200	199 286 203	199 286 213	0.850
25	20	10	470	199 286 204	199 286 214	0.943
32	25	10	793	199 286 205	199 286 215	1.071
40	32	10	1290	199 286 206	199 286 216	1.800
50	40	10	1910	199 286 207	199 286 217	2.117
63	50	10	3100	199 286 208	199 286 218	3.049

d [mm]	D [mm]	H [mm]	H1 [mm]	H2 [mm]	H3 [mm]	H4 [mm]	H5 [mm]	H6 [mm]	L [mm]	L1 [mm]	L2 [mm]	L3 [mm]	L4 [mm]	L5 [mm]	L6 [mm]
16	50	159	28	62	97	40	77	8	126	194	72	36	25	261	76
20	50	159	28	62	97	40	77	8	136	194	72	36	25	261	76
25	58	168	32	71	97	40	77	8	159	194	85	43	25	261	76
32	68	168	36	71	97	40	77	8	178	194	98	49	25	261	76
40	84	203	45	84	119	51	99	9	204	224	118	59	45	305	95
50	97	203	51	84	119	51	99	9	237	224	135	68	45	305	95
63	124	225	65	106	119	51	99	9	296	224	176	88	45	305	95

d [mm]	L7 [mm]	M
16	48	6
20	48	6
25	48	6
32	48	6
40	59	8
50	59	8
63	59	8

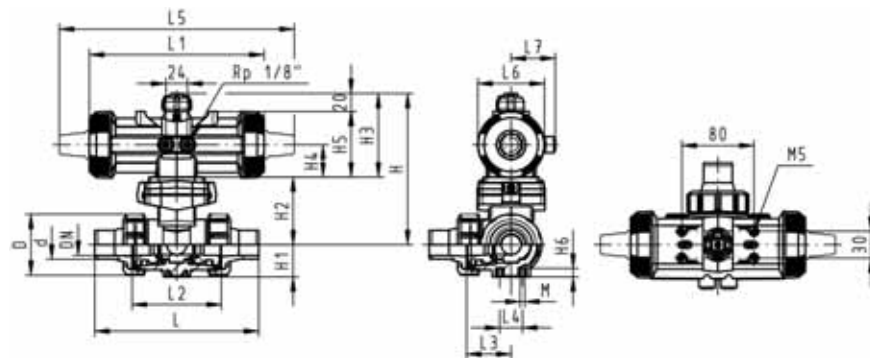



PROGEF Standard
3-Way ball valve type 286
Horizontal/T-port DA (Double acting)
Without manual override
With butt fusion spigots
IR-Plus SDR11 metric

Model:

- Material: PP-H
- Built on with pneumatic actuator PA11 (DN10/15-25), PA21 (DN32-50)
- Basic position A-B-C opened, activated position B-C opened, see flow scheme
- Control time $90^\circ <$) 1-3 s
- For easy installation and removal
- Integrated stainless steel mounting inserts

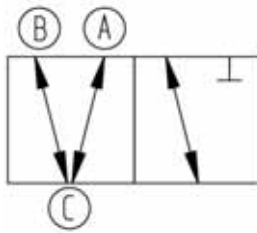
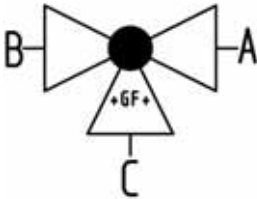

d [mm]	DN [mm]	PN	kv-value ($\Delta p=1$ bar) [l/min]	EPDM Code	FPM Code	kg
20	15	10	200	199 286 263	199 286 273	0.850
25	20	10	470	199 286 264	199 286 274	0.943
32	25	10	793	199 286 265	199 286 275	1.071
40	32	10	1290	199 286 266	199 286 276	1.800
50	40	10	1910	199 286 267	199 286 277	2.117
63	50	10	3100	199 286 268	199 286 278	3.049

d [mm]	D [mm]	H [mm]	H1 [mm]	H2 [mm]	H3 [mm]	H4 [mm]	H5 [mm]	H6 [mm]	L [mm]	L1 [mm]	L2 [mm]	L3 [mm]	L4 [mm]	L5 [mm]	L6 [mm]
20	50	159	28	62	97	40	77	8	146	194	72	36	25	261	76
25	58	168	32	71	97	40	77	8	163	194	85	43	25	261	76
32	68	168	36	71	97	40	77	8	178	194	98	49	25	261	76
40	84	203	45	84	119	51	99	9	204	224	118	59	45	305	95
50	97	203	51	84	119	51	99	9	237	224	135	68	45	305	95
63	124	225	65	106	119	51	99	9	296	224	176	88	45	305	95

d [mm]	L7 [mm]	M
20	48	6
25	48	6
32	48	6
40	59	8
50	59	8
63	59	8

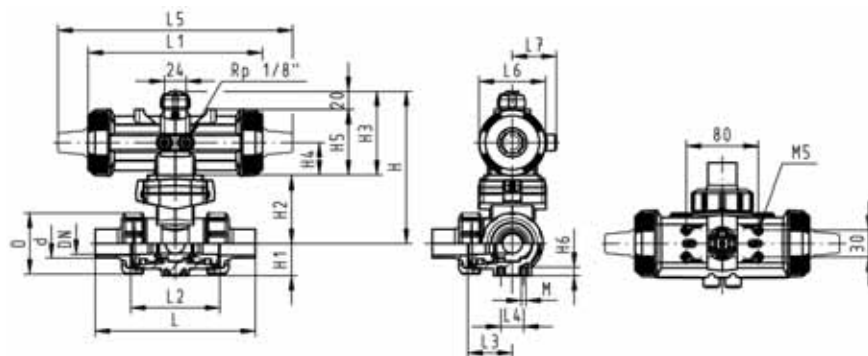

Diaphragm valves pneumatic

New generation

PROGEF Standard

Diaphragm valve DIASTAR Six

FC (Fail safe to close)

Unions with fusion sockets metric

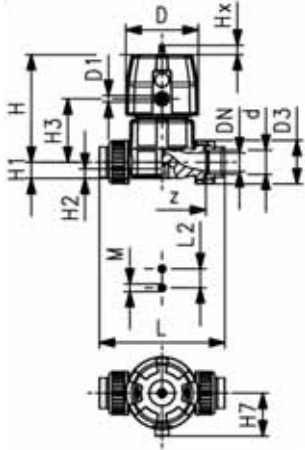

Model:

- Material: PP-H
- Double flow rate compared to predecessor
- One housing nut replaces four screws
- Rotating air connection at 90° intervals
- For easy installation and removal
- Short overall length

Option:

- Individual configuration of the valve (see diagram)

d [mm]	DN [mm]	PN	kv-value ($\Delta p=1$ bar) [l/min]	EPDM Code	kg
20	15	6	125	167 614 012	0.529
25	20	6	271	167 614 013	0.974
32	25	6	481	167 614 014	1.180
40	32	6	759	167 614 015	1.949
50	40	6	960	167 614 016	2.450
63	50	6	1181	167 614 017	3.153

d [mm]	D [mm]	D1_G [inch]	L [mm]	L2 [mm]	H [mm]	H1 [mm]	H2 [mm]	H3 [mm]	H7 [mm]	M	z [mm]	Lift = Hx [mm]
20	68	1/8	128	25	101	14	12	60	43	M6	100	7
25	96	1/8	150	25	132	18	12	73	57	M6	118	10
32	96	1/8	162	25	143	22	12	84	57	M6	126	13
40	120	1/8	184	45	173	26	15	99	69	M8	144	14
50	120	1/8	210	45	193	32	15	119	69	M8	164	16
63	120	1/8	248	45	205	39	15	132	69	M8	194	16

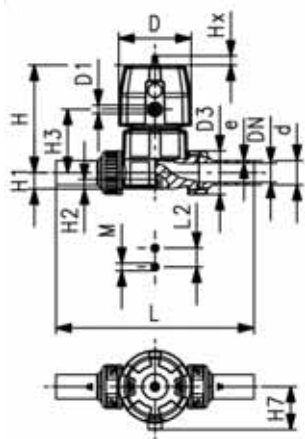

PROGEF Standard

Diaphragm valve DIASTAR Six

FC (Fail safe to close)

Unions with butt fusion spigots SDR11 metric

Model:

- Material: PP-H
- Double flow rate compared to predecessor
- One housing nut replaces four screws
- Rotating air connection at 90° intervals
- For easy installation and removal
- Short overall length

Option:

- Individual configuration of the valve (see diagram)

d [mm]	DN [mm]	PN	kv-value ($\Delta p=1$ bar) [l/min]	EPDM Code	kg
20	15	6	125	167 614 112	0.537
25	20	6	271	167 614 113	0.871
32	25	6	481	167 614 114	1.589
40	32	6	759	167 614 115	1.805
50	40	6	960	167 614 116	2.279
63	50	6	1181	167 614 117	3.421

table continued next page

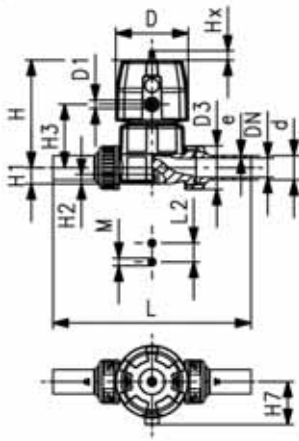

d [mm]	D [mm]	D1_G [inch]	L [mm]	L2 [mm]	H [mm]	H1 [mm]	H2 [mm]	H3 [mm]	H7 [mm]	M	Lift = Hx [mm]	e [mm]
20	68	1/8	196	25	101	14	12	60	43	M6	7	1.9
25	96	1/8	221	25	132	18	12	73	57	M6	10	2.3
32	96	1/8	234	25	143	22	12	84	57	M6	13	2.9
40	120	1/8	260	45	173	26	15	99	69	M8	14	3.7
50	120	1/8	284	45	193	32	15	119	69	M8	16	4.6
63	120	1/8	321	45	205	39	15	132	69	M8	16	5.8



PROGEF Standard Diaphragm valve DIASTAR Six FC (Fail safe to close) With socket fusion spigots metric

Model:

- Material: PP-H
- Double flow rate compared to predecessor
- One housing nut replaces four screws
- Rotating air connection at 90° intervals
- Overall length EN 558

Option:

- Individual configuration of the valve (see diagram)

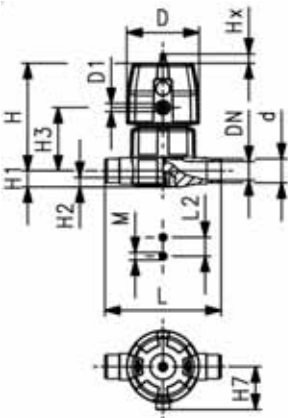

d [mm]	DN [mm]	PN	kv-value ($\Delta p=1$ bar) [l/min]	EPDM Code	kg
20	15	6	125	167 615 012	0.466
25	20	6	271	167 615 013	0.903
32	25	6	481	167 615 014	1.054
40	32	6	759	167 615 015	1.747
50	40	6	960	167 615 016	2.207
63	50	6	1181	167 615 017	2.981

d [mm]	D [mm]	D1_G [inch]	L [mm]	L2 [mm]	H [mm]	H1 [mm]	H2 [mm]	H3 [mm]	H7 [mm]	M	Lift = Hx [mm]	e [mm]
20	68	1/8	124	25	101	14	12	60	43	M6	7	1.9
25	96	1/8	144	25	132	18	12	73	57	M6	10	2.3
32	96	1/8	154	25	143	22	12	84	57	M6	13	2.9
40	120	1/8	174	45	173	26	15	99	69	M8	14	3.7
50	120	1/8	194	45	193	32	15	119	69	M8	16	4.6
63	120	1/8	224	45	205	39	15	132	69	M8	16	5.8



PROGEF Standard Diaphragm valve DIASTAR Six FC (Fail safe to close) With butt fusion spigots SDR11 metric

Model:

- Material: PP-H
- Double flow rate compared to predecessor
- One housing nut replaces four screws
- Rotating air connection at 90° intervals

Option:

- Individual configuration of the valve (see diagram)

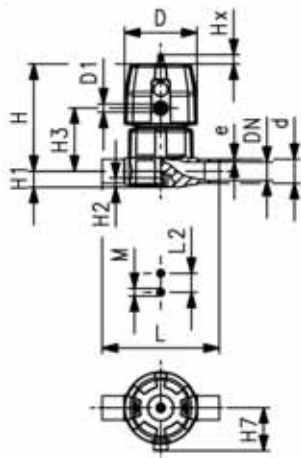

d [mm]	DN [mm]	PN	kv-value ($\Delta p=1$ bar) [l/min]	EPDM Code	kg
20	15	6	125	167 615 112	0.465
25	20	6	271	167 615 113	0.899
32	25	6	481	167 615 114	1.062
40	32	6	759	167 615 115	1.743
50	40	6	960	167 615 116	2.202
63	50	6	1181	167 615 117	2.978

d [mm]	D [mm]	D1_G [inch]	L [mm]	L2 [mm]	H [mm]	H1 [mm]	H2 [mm]	H3 [mm]	H7 [mm]	M	Lift = Hx [mm]	e [mm]
20	68	1/8	124	25	101	14	12	60	43	M6	7	1.9
25	96	1/8	144	25	132	18	12	73	57	M6	10	2.3
32	96	1/8	154	25	143	22	12	84	57	M6	13	2.9
40	120	1/8	174	45	173	26	15	99	69	M8	14	3.7
50	120	1/8	194	45	193	32	15	119	69	M8	16	4.6
63	120	1/8	224	45	205	39	15	132	69	M8	16	5.8



PROGEF Standard Diaphragm valve DIASTAR Six FC (Fail safe to close) With backing flanges PP-V metric/BS

Model:

- Material: PP-H
- Double flow rate compared to predecessor
- One housing nut replaces four screws
- Rotating air connection at 90° intervals
- Flat sealing faces/serrated
- Overall length EN 558
- Connecting dimension: ISO 7005 PN 10, EN 1092 PN 10, DIN 2501 PN 10, BS 4504 PN 10

Option:

- Individual configuration of the valve (see diagram)

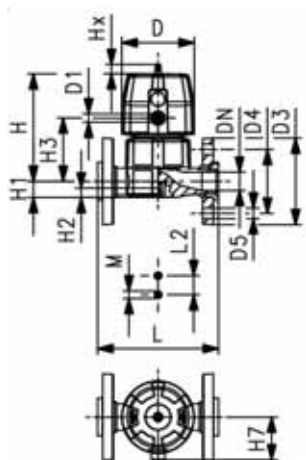

d [mm]	DN [mm]	PN	kv-value ($\Delta p=1$ bar) [l/min]	EPDM Code	kg
20	15	6	125	167 617 112	0.648
25	20	6	271	167 617 113	1.148
32	25	6	481	167 617 114	1.410
40	32	6	759	167 617 115	2.279
50	40	6	960	167 617 116	2.751
63	50	6	1181	167 617 117	3.921

d [mm]	D [mm]	D1_G [inch]	D3 [mm]	D4 [mm]	D5 [mm]	L [mm]	L2 [mm]	H [mm]	H1 [mm]	H2 [mm]	H3 [mm]	H7 [mm]	M	Lift = Hx [mm]
20	68	1/8	95	65	14	130	25	101	14	12	60	43	M6	7
25	96	1/8	105	75	14	150	25	132	18	12	73	57	M6	10
32	96	1/8	115	85	14	160	25	143	22	12	84	69	M6	13

table continued next page

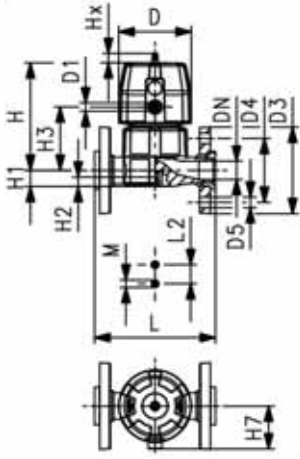

d [mm]	D [mm]	D1_G [inch]	D3 [mm]	D4 [mm]	D5 [mm]	L [mm]	L2 [mm]	H [mm]	H1 [mm]	H2 [mm]	H3 [mm]	H7 [mm]	M	Lift = Hx [mm]
40	120	1/8	140	100	18	180	45	173	26	15	99	69	M8	14
50	120	1/8	150	110	18	200	45	193	32	15	119	69	M8	16
63	120	1/8	165	125	18	230	45	205	39	15	132	69	M8	16



PROGEF Standard Diaphragm valve DIASTAR Six FC (Fail safe to close) With backing flanges PP-V Inch ANSI

Model:

- Material: PP-H
- Double flow rate compared to predecessor
- One housing nut replaces four screws
- Rotating air connection at 90° intervals
- Flat sealing faces/serrated
- Connecting dimension: ANSI/ASME B 16.5 class 150, ASTM D 4024, BS 1560, BS EN 1759

Option:

- Individual configuration of the valve (see diagram)

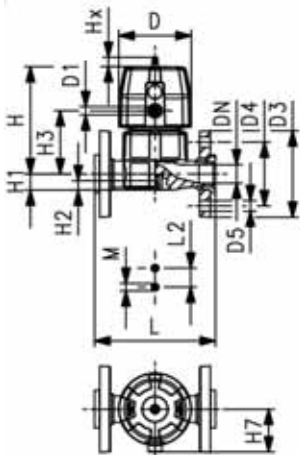

Inch	DN [mm]	PN	kv-value (Δp=1 bar) [l/min]	EPDM Code	kg
1/2	15	6	125	167 617 712	0.648
3/4	20	6	271	167 617 713	1.148
1	25	6	481	167 617 714	1.410
1 1/4	32	6	759	167 617 715	2.279
1 1/2	40	6	960	167 617 716	2.751
2	50	6	1181	167 617 717	3.921

Inch	D [mm]	D1_G [inch]	D3 [mm]	D4 [mm]	D5 [mm]	L [mm]	L2 [mm]	H [mm]	H1 [mm]	H2 [mm]	H3 [mm]	H7 [mm]	M	Lift = Hx [mm]
1/2	68	1/8	95	60	16	130	25	101	14	12	60	43	M6	7
3/4	96	1/8	105	70	16	150	25	132	18	12	73	57	M6	10
1	96	1/8	115	79	16	160	25	143	22	12	84	69	M6	13
1 1/4	120	1/8	140	89	16	180	45	173	26	15	99	69	M8	14
1 1/2	120	1/8	150	98	16	200	45	193	32	15	119	69	M8	16
2	120	1/8	165	121	19	230	45	205	39	15	132	69	M8	16



PROGEF Standard Diaphragm valve DIASTAR Six FC (Fail safe to close) With fixed flanges PP-H JIS

Model:

- Material: PP-H
- Double flow rate compared to predecessor
- One housing nut replaces four screws
- Rotating air connection at 90° intervals
- Flat sealing faces/serrated
- Connecting dimension: JIS B2238/39 10K

Option:

- Individual configuration of the valve (see diagram)

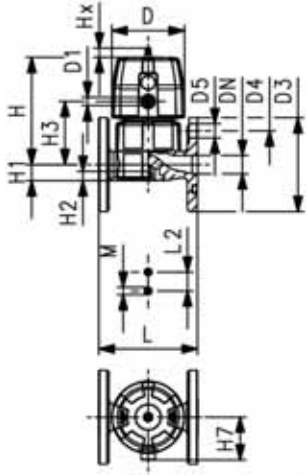

Inch	DN [mm]	PN	kv-value ($\Delta p=1$ bar) [l/min]	EPDM Code	kg
½	15	6	125	167 617 912	0.593
¾	20	6	271	167 617 913	1.023
1	25	6	481	167 617 914	1.263
1 ¼	32	6	759	167 617 915	2.082
1 ½	40	6	960	167 617 916	2.570
2	50	6	1181	167 617 917	3.432

Inch	D [mm]	D1_G [inch]	D3 [mm]	D4 [mm]	D5 [mm]	L [mm]	L2 [mm]	H [mm]	H1 [mm]	H2 [mm]	H3 [mm]	H7 [mm]	M	Lift = Hx [mm]
½	68	¾	95	70	15	110	25	101	14	12	60	43	M6	7
¾	96	¾	100	75	15	120	25	132	18	12	73	57	M6	10
1	96	¾	125	90	19	130	25	143	22	12	84	69	M6	13
1 ¼	120	¾	135	100	19	180	45	173	26	15	99	69	M8	14
1 ½	120	¾	140	105	19	180	45	193	32	15	119	69	M8	16
2	120	¾	155	120	19	210	45	205	39	15	132	69	M8	16



PROGEF Standard Diaphragm valve DIASTAR Ten FC (Fail safe to close) Unions with fusion sockets metric

Model:

- Material: PP-H
- Double flow rate compared to predecessor
- One housing nut replaces four screws
- Rotating air connection at 90° intervals
- For easy installation and removal
- Short overall length

Option:

- Individual configuration of the valve (see diagram)
- Comprehensive range of accessories available

* PN: PTFE

Working Pressure: **one side**

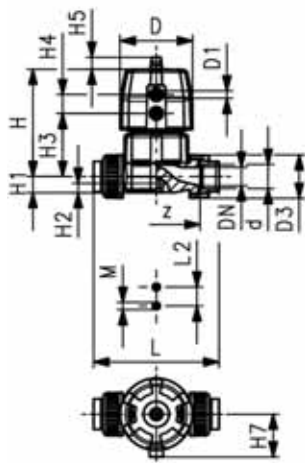

d [mm]	DN [mm]	PN* [bar]	kv-value ($\Delta p=1$ bar) [l/min]	EPDM Code	PTFE/EPDM Code	kg
20	15	10/10*	125	167 624 012	167 624 032	0.526
25	20	10/10*	271	167 624 013	167 624 033	1.071
32	25	10/10*	481	167 624 014	167 624 034	1.286
40	32	10/10*	759	167 624 015	167 624 035	2.152
50	40	10/10*	1263	167 624 016	167 624 036	3.623
63	50	10/6*	1728	167 624 017	167 624 037	5.032

d [mm]	D [mm]	D1_G [inch]	L [mm]	L2 [mm]	H [mm]	H1 [mm]	H2 [mm]	H3 [mm]	H4 [mm]	H5 [mm]	H7 [mm]	M	z [mm]	Lift = Hx [mm]
20	68	1/8	128	25	101	14	12	60	24	16	43	M6	100	7
25	96	1/8	150	25	132	18	12	73	25	16	57	M6	118	10
32	96	1/8	162	25	143	22	12	84	25	16	57	M6	126	13
40	120	1/8	184	45	173	26	15	99	26	26	69	M8	144	15
50	150	1/4	210	45	214	32	15	119	36	26	88	M8	164	19
63	150	1/4	248	45	226	39	15	132	36	26	88	M8	194	23



PROGEF Standard Diaphragm valve DIASTAR Ten FC (Fail safe to close) Unions with butt fusion spigots SDR11 metric

Model:

- Material: PP-H
- Double flow rate compared to predecessor
- One housing nut replaces four screws
- Rotating air connection at 90° intervals
- For easy installation and removal
- Short overall length

Option:

- Individual configuration of the valve (see diagram)
- Comprehensive range of accessories available

* PN: PTFE

Working Pressure: **one side**

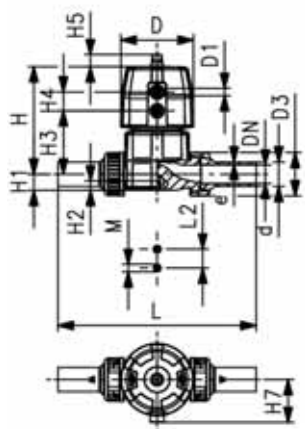

d [mm]	DN [mm]	PN* [bar]	kv-value ($\Delta p=1$ bar) [l/min]	EPDM Code	PTFE/EPDM Code	kg
20	15	10/10*	125	167 624 112	167 624 132	0.533
25	20	10/10*	271	167 624 113	167 624 133	0.971
32	25	10/10*	481	167 624 114	167 624 134	1.698
40	32	10/10*	759	167 624 115	167 624 135	2.682
50	40	10/10*	1263	167 624 116	167 624 136	4.378
63	50	10/6*	1728	167 624 117	167 624 137	4.076

table continued next page

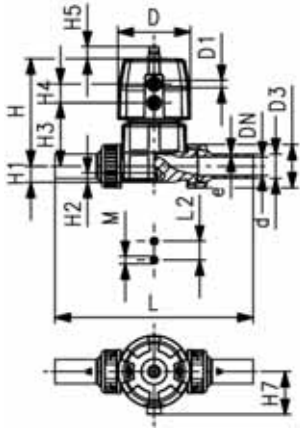

d [mm]	D [mm]	D1_G [inch]	L [mm]	L2 [mm]	H [mm]	H1 [mm]	H2 [mm]	H3 [mm]	H4 [mm]	H5 [mm]	H7 [mm]	M	Lift = Hx [mm]	e [mm]
20	68	1/8	196	25	101	14	12	60	24	16	43	M6	7	1.9
25	96	1/8	221	25	132	18	12	73	25	16	57	M6	10	2.3
32	96	1/8	234	25	143	22	12	84	25	16	57	M6	13	2.9
40	120	1/8	260	45	173	26	15	99	26	26	69	M8	15	3.7
50	150	1/4	284	45	214	32	15	119	36	26	88	M8	19	4.6
63	150	1/4	321	45	226	39	15	132	36	26	88	M8	23	5.8



PROGEF Standard Diaphragm valve DIASTAR Ten FC (Fail safe to close) With socket fusion spigots metric

Model:

- Material: PP-H
- Double flow rate compared to predecessor
- One housing nut replaces four screws
- Rotating air connection at 90° intervals
- Overall length EN 558

Option:

- Individual configuration of the valve (see diagram)
- Comprehensive range of accessories available

* PN: PTFE

Working Pressure: **one side**

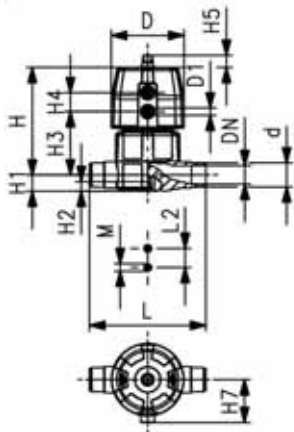

d [mm]	DN [mm]	PN* [bar]	kv-value (Δp=1 bar) [l/min]	EPDM Code	PTFE/EPDM Code	kg
20	15	10/10*	125	167 625 012	167 625 032	0.502
25	20	10/10*	271	167 625 013	167 625 033	0.990
32	25	10/10*	481	167 625 014	167 625 034	1.156
40	32	10/10*	759	167 625 015	167 625 035	1.917
50	40	10/10*	1263	167 625 016	167 625 036	3.375
63	50	10/6*	1728	167 625 017	167 625 037	4.054

d [mm]	D [mm]	D1_G [inch]	L [mm]	L2 [mm]	H [mm]	H1 [mm]	H2 [mm]	H3 [mm]	H4 [mm]	H5 [mm]	H7 [mm]	M	Lift = Hx [mm]	e [mm]
20	68	1/8	124	25	101	14	12	60	24	16	43	M6	7	1.9
25	96	1/8	144	25	132	18	12	73	25	16	57	M6	10	2.3
32	96	1/8	154	25	143	22	12	84	25	16	57	M6	13	2.9
40	120	1/8	174	45	173	26	15	99	26	26	69	M8	15	3.7
50	150	1/4	194	45	214	32	15	119	36	26	88	M8	19	4.6
63	150	1/4	224	45	226	39	15	132	36	26	88	M8	23	5.8



PROGEF Standard Diaphragm valve DIASTAR Ten FC (Fail safe to close) With butt fusion spigots SDR11 metric

Model:

- Material: PP-H
- Double flow rate compared to predecessor
- One housing nut replaces four screws
- Rotating air connection at 90° intervals

Option:

- Individual configuration of the valve (see diagram)
- Comprehensive range of accessories available

* PN: PTFE

Working Pressure: **one side**

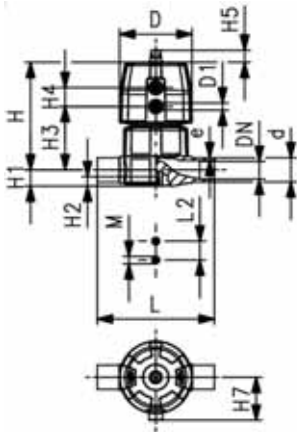

d [mm]	DN [mm]	PN* [bar]	kv-value ($\Delta p=1$ bar) [l/min]	EPDM Code	PTFE/EPDM Code	kg
20	15	10/10*	125	167 625 112	167 625 132	0.501
25	20	10/10*	271	167 625 113	167 625 133	0.986
32	25	10/10*	481	167 625 114	167 625 134	1.154
40	32	10/10*	759	167 625 115	167 625 135	1.913
50	40	10/10*	1263	167 625 116	167 625 136	3.370
63	50	10/6*	1728	167 625 117	167 625 137	3.927

d [mm]	D [mm]	D1_G [inch]	L [mm]	L2 [mm]	H [mm]	H1 [mm]	H2 [mm]	H3 [mm]	H4 [mm]	H5 [mm]	H7 [mm]	M	Lift = Hx [mm]
20	68	1/8	124	25	101	14	12	60	24	16	43	M6	7
25	96	1/8	144	25	132	18	12	73	25	16	57	M6	10
32	96	1/8	154	25	143	22	12	84	25	16	57	M6	13
40	120	1/8	174	45	173	26	15	99	26	26	69	M8	15
50	150	1/4	194	45	214	32	15	119	36	26	88	M8	19
63	150	1/4	224	45	226	39	15	132	36	26	88	M8	23



PROGEF Standard Diaphragm valve DIASTAR Ten FC (Fail safe to close) With backing flanges PP-V metric/BS

Model:

- Material: PP-H
- Double flow rate compared to predecessor
- One housing nut replaces four screws
- Rotating air connection at 90° intervals
- Flat sealing faces/serrated
- Overall length EN 558
- Connecting dimension: ISO 7005 PN 10, EN 1092 PN 10, DIN 2501 PN 10, BS 4504 PN 10

Option:

- Individual configuration of the valve (see diagram)
- Comprehensive range of accessories available

* PN: PTFE

Working Pressure: **one side**

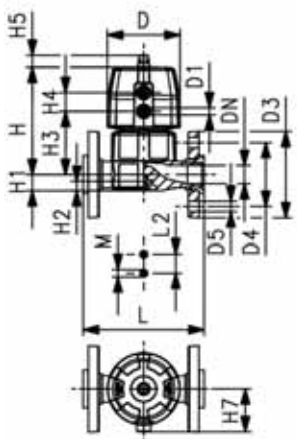

d [mm]	DN [mm]	PN* [bar]	kv-value ($\Delta p=1$ bar) [l/min]	EPDM Code	PTFE/EPDM Code	kg
20	15	10/10*	125	167 627 112	167 627 132	0.684
25	20	10/10*	271	167 627 113	167 627 133	1.234
32	25	10/10*	481	167 627 114	167 627 134	1.526
40	32	10/10*	759	167 627 115	167 627 135	2.562
50	40	10/10*	1263	167 627 116	167 627 136	3.919
63	50	10/6*	1728	167 627 117	167 627 137	4.952

table continued next page

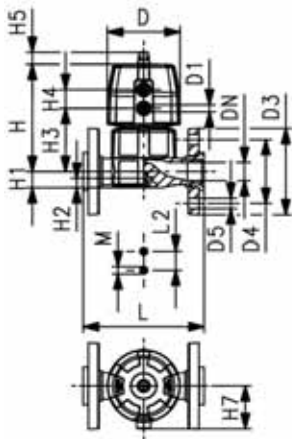

d	D	D1_G	D3	D4	D5	L	L2	H	H1	H2	H3	H4	H5	H7	M
[mm]	[mm]	[inch]	[mm]	[mm]	[mm]	[mm]	[mm]	[mm]	[mm]	[mm]	[mm]	[mm]	[mm]	[mm]	
20	68	1/8	95	65	14	130	25	101	14	12	60	24	16	43	M6
25	96	1/8	105	75	14	150	25	132	18	12	73	25	16	57	M6
32	96	1/8	115	85	14	160	25	143	22	12	84	25	16	69	M6
40	120	1/8	140	100	18	180	45	173	26	15	99	26	26	69	M8
50	150	1/4	150	110	18	200	45	193	32	15	119	36	26	88	M8
63	150	1/4	165	125	18	230	45	205	39	15	132	36	26	88	M8

d	Lift = Hx
[mm]	[mm]
20	7
25	10
32	13
40	15
50	19
63	23



PROGEF Standard Diaphragm valve DIASTAR Ten FC (Fail safe to close) With backing flanges PP-V Inch ANSI

Model:

- Material: PP-H
- Double flow rate compared to predecessor
- One housing nut replaces four screws
- Rotating air connection at 90° intervals
- Flat sealing faces/serrated
- Connecting dimension: ANSI/ASME B 16.5 class 150, ASTM D 4024, BS 1560, BS EN 1759

Option:

- Individual configuration of the valve (see diagram)
- Comprehensive range of accessories available

* PN: PTFE

Working Pressure: **one side**

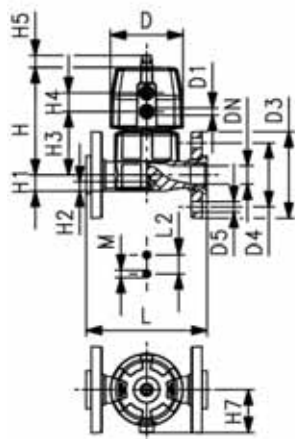

Inch	DN	PN*	kv-value (Δp=1 bar)	EPDM Code	PTFE/EPDM Code	kg
	[mm]	[bar]	[l/min]			
1/2	15	10/10*	125	167 627 712	167 627 732	0.684
3/4	20	10/10*	271	167 627 713	167 627 733	1.234
1	25	10/10*	481	167 627 714	167 627 734	1.502
1 1/4	32	10/10*	759	167 627 715	167 627 735	2.449
1 1/2	40	10/10*	1263	167 627 716	167 627 736	3.919
2	50	10/6*	1728	167 627 717	167 627 737	4.870

Inch	D	D1_G	D3	D4	D5	L	L2	H	H1	H2	H3	H4	H5	H7	M
	[mm]	[inch]	[mm]	[mm]	[mm]	[mm]	[mm]	[mm]	[mm]	[mm]	[mm]	[mm]	[mm]	[mm]	
1/2	68	1/8	95	60	16	130	25	101	14	12	60	24	16	43	M6
3/4	96	1/8	105	70	16	150	25	132	18	12	73	25	16	57	M6
1	96	1/8	115	79	16	160	25	143	22	12	84	25	16	69	M6
1 1/4	120	1/8	140	89	16	180	45	173	26	15	99	26	26	69	M8
1 1/2	150	1/4	150	98	16	200	45	193	32	15	119	36	26	88	M8
2	150	1/4	165	121	19	230	45	205	39	15	132	36	26	88	M8

Inch	Lift = Hx
	[mm]
1/2	7
3/4	10
1	13
1 1/4	15
1 1/2	19
2	23



PROGEF Standard Diaphragm valve type DIASTAR Series 025 FC (Fail safe to close) With fixed flanges PP metric

Model:

- Material: PP-H
- Connecting dimensions: ISO 7005 / EN 1092 / DIN 2501 PN10 / BS4504
- With position indicator / Working pressure: **one side**

* With backing flanges PP-V

** Connecting dimensions DN80 and DN150 metric and Inch ANSI B16.5

d [mm]	DN [mm]	Inch	PN	kv-value ($\Delta p=1$ bar) [l/min]	EPDM Code	PTFE/EPDM Code	kg
* 75	65	2 ½	10	992	199 025 267	199 025 297	14.715
** 90	80	3	10	1700	199 025 268	199 025 298	16.162
110	100	4	6	2700	199 025 269	199 025 299	24.700
** 160	150	6	6	6033	199 025 270	-	35.000

d [mm]	D [mm]	D1_G [inch]	D2 [mm]	D3[M] [mm]	D4 [mm]	L [mm]	L2 [mm]	L3 [mm]	H [mm]	H1 [mm]	H2 [mm]	H3 [mm]	H4 [mm]	H5 [mm]
* 75	280	¼	185	8	145	290	70		344	148	24	46	100	129
** 90	280	¼	200	12	160	310	120		348	150	24	46	100	129
110	335	¼	225	12	180	350	120		395	176	24	46	100	129
** 160	335	¼	285	12	240	480	100	200	455	237	24	46	100	129

d [mm]	H6 [mm]	H7 [mm]	H9 [mm]	H10 [mm]
* 75	195	298	46	15
** 90	195	302	57	15
110	195	349	69	20
** 160	195	409	108	20

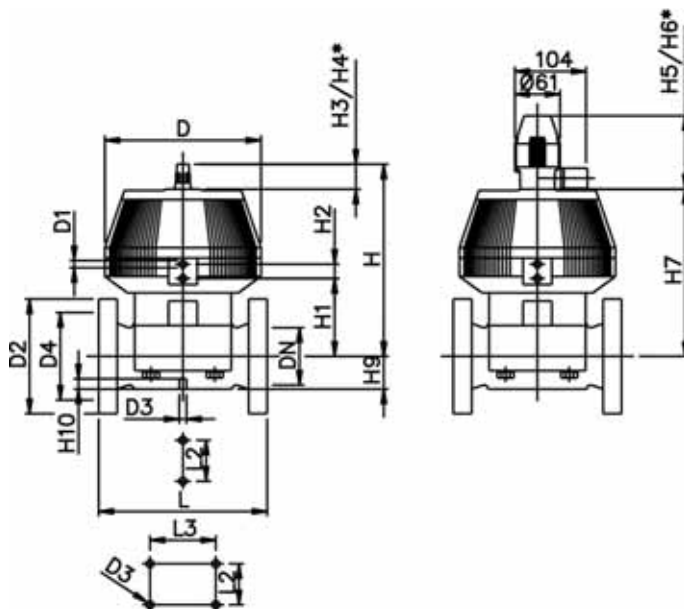



PROGEF Standard Diaphragm valve DIASTAR Ten FC (Fail safe to close) With fixed flanges PP-H JIS

Model:

- Material: PP-H
- Double flow rate compared to predecessor
- One housing nut replaces four screws
- Rotating air connection at 90° intervals
- Connecting dimension: JIS B2238/39 10K
- Flat sealing faces/serrated

Option:

- Individual configuration of the valve (see diagram)
- Comprehensive range of accessories available

* PN: PTFE

Working Pressure: **one side**

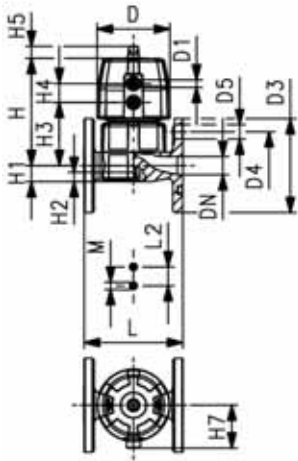

Inch	DN [mm]	PN* [bar]	kv-value ($\Delta p=1$ bar) [l/min]	EPDM Code	PTFE/EPDM Code	kg
1/2	15	10/10*	125	167 627 912	167 627 932	0.628
3/4	20	10/10*	271	167 627 913	167 627 933	1.108
1	25	10/10*	481	167 627 914	167 627 934	1.354
1 1/4	32	10/10*	759	167 627 915	167 627 935	2.251
1 1/2	40	10/10*	1263	167 627 916	167 627 936	3.737
2	50	10/6*	1728	167 627 917	167 627 937	4.380

Inch	D [mm]	D1_G [inch]	D3 [mm]	D4 [mm]	D5 [mm]	L [mm]	L2 [mm]	H [mm]	H1 [mm]	H2 [mm]	H3 [mm]	H4 [mm]	H5 [mm]	H7 [mm]	M
1/2	68	1/8	95	70	15	110	25	101	14	12	60	24	16	43	M6
3/4	96	1/8	100	75	15	120	25	132	18	12	73	25	16	57	M6
1	96	1/8	125	90	19	130	25	143	22	12	84	25	16	69	M6
1 1/4	120	1/8	135	100	19	180	45	173	26	15	99	26	26	69	M8
1 1/2	150	1/4	140	105	19	180	45	193	32	15	119	36	26	88	M8
2	150	1/4	155	120	19	210	45	205	39	15	132	36	26	88	M8

Inch	Lift = Hx [mm]
1/2	7
3/4	10
1	13
1 1/4	15
1 1/2	19
2	23



PROGEF Standard Diaphragm valve DIASTAR Ten FO (Fail safe to open) Unions with fusion sockets metric

Model:

- Material: PP-H
- Double flow rate compared to predecessor
- One housing nut replaces four screws
- Rotating air connection at 90° intervals
- For easy installation and removal
- Short overall length

Option:

- Individual configuration of the valve (see diagram)
- Comprehensive range of accessories available

* PN: PTFE

Working Pressure: **one side**

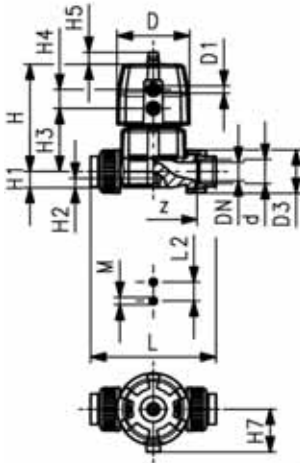

d [mm]	DN [mm]	PN* [bar]	kv-value ($\Delta p=1$ bar) [l/min]	EPDM Code	PTFE/EPDM Code	kg
20	15	10/10*	125	167 644 012	167 644 032	0.515
25	20	10/10*	271	167 644 013	167 644 033	0.919
32	25	10/10*	481	167 644 014	167 644 034	1.079
40	32	10/10*	759	167 644 015	167 644 035	1.726
50	40	10/10*	1263	167 644 016	167 644 036	3.533
63	50	10/10*	1728	167 644 017	167 644 037	4.266

d [mm]	D [mm]	D1_G [inch]	L [mm]	L2 [mm]	H [mm]	H1 [mm]	H2 [mm]	H3 [mm]	H4 [mm]	H5 [mm]	H7 [mm]	M	z [mm]	Lift = Hx [mm]
20	68	1/8	128	25	101	14	12	60	24	16	43	M6	100	7
25	96	1/8	152	25	132	18	12	73	25	16	57	M6	118	10
32	96	1/8	166	25	143	22	12	84	25	16	57	M6	126	13
40	120	1/8	192	45	173	26	15	99	26	26	69	M8	144	15
50	150	1/4	222	45	214	32	15	119	36	26	88	M8	164	19
63	150	1/4	266	45	226	39	15	132	36	26	88	M8	194	23



PROGEF Standard Diaphragm valve DIASTAR Ten FO (Fail safe to open) Unions with butt fusion spigots SDR11 metric

Model:

- Material: PP-H
- Double flow rate compared to predecessor
- One housing nut replaces four screws
- Rotating air connection at 90° intervals
- For easy installation and removal
- Short overall length

Option:

- Individual configuration of the valve (see diagram)
- Comprehensive range of accessories available

* PN: PTFE

Working Pressure: **one side**

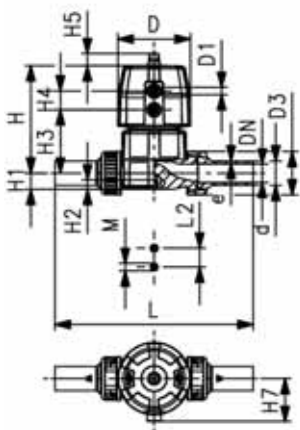

d [mm]	DN [mm]	PN* [bar]	kv-value ($\Delta p=1$ bar) [l/min]	EPDM Code	PTFE/EPDM Code	kg
20	15	10/10*	125	167 644 112	167 644 132	0.510
25	20	10/10*	271	167 644 113	167 644 133	0.931
32	25	10/10*	481	167 644 114	167 644 134	1.482
40	32	10/10*	759	167 644 115	167 644 135	1.647
50	40	10/10*	1263	167 644 116	167 644 136	3.541
63	50	10/10*	1728	167 644 117	167 644 137	3.426

table continued next page

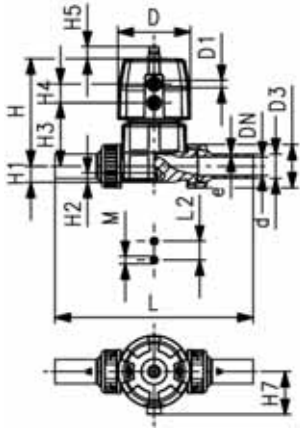

d [mm]	D [mm]	D1_G [inch]	L [mm]	L2 [mm]	H [mm]	H1 [mm]	H2 [mm]	H3 [mm]	H4 [mm]	H5 [mm]	H7 [mm]	M	Lift = Hx [mm]	e [mm]
20	68	1/8	196	25	101	14	12	60	24	16	43	M6	7	1.9
25	96	1/8	221	25	132	18	12	73	25	16	57	M6	10	2.3
32	96	1/8	234	25	143	22	12	84	25	16	57	M6	13	2.9
40	120	1/8	260	45	173	26	15	99	26	26	69	M8	15	3.7
50	150	1/4	284	45	214	32	15	119	36	26	69	M8	19	4.6
63	150	1/4	321	45	226	39	15	132	36	26	69	M8	23	5.8



PROGEF Standard Diaphragm valve DIASTAR Ten FO (Fail safe to open) With socket fusion spigots metric

Model:

- Material: PP-H
- Double flow rate compared to predecessor
- One housing nut replaces four screws
- Rotating air connection at 90° intervals
- Overall length EN 558

Option:

- Individual configuration of the valve (see diagram)
- Comprehensive range of accessories available

* PN: PTFE

Working Pressure: **one side**

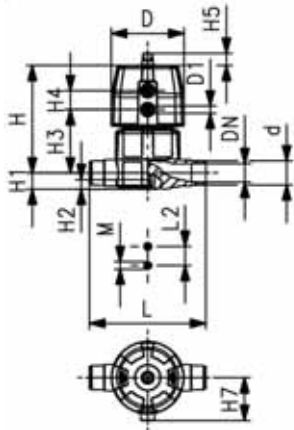

d [mm]	DN [mm]	PN* [bar]	kv-value ($\Delta p=1$ bar) [l/min]	EPDM Code	PTFE/EPDM Code	kg
20	15	10/10*	125	167 645 012	167 645 032	0.452
25	20	10/10*	271	167 645 013	167 645 033	0.816
32	25	10/10*	481	167 645 014	167 645 034	0.976
40	32	10/10*	759	167 645 015	167 645 035	1.557
50	40	10/10*	1263	167 645 016	167 645 036	3.285
63	50	10/10*	1728	167 645 017	167 645 037	3.840

d [mm]	D [mm]	D1_G [inch]	L [mm]	L2 [mm]	H [mm]	H1 [mm]	H2 [mm]	H3 [mm]	H4 [mm]	H5 [mm]	H7 [mm]	M	Lift = Hx [mm]	e [mm]
20	68	1/8	124	25	101	14	12	60	24	16	43	M6	7	1.9
25	96	1/8	144	25	132	18	12	73	25	16	57	M6	10	2.3
32	96	1/8	154	25	143	22	12	84	25	16	57	M6	13	2.9
40	120	1/8	174	45	173	26	15	99	26	26	69	M8	15	3.7
50	150	1/4	194	45	214	32	15	119	36	26	88	M8	19	4.6
63	150	1/4	224	45	226	39	15	132	36	26	88	M8	23	5.8



PROGEF Standard Diaphragm valve DIASTAR Ten FO (Fail safe to open) With butt fusion spigots SDR11 metric

Model:

- Material: PP-H
- Double flow rate compared to predecessor
- One housing nut replaces four screws
- Rotating air connection at 90° intervals

Option:

- Individual configuration of the valve (see diagram)
- Comprehensive range of accessories available

* PN: PTFE

Working Pressure: **one side**

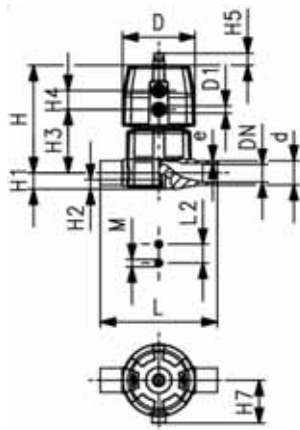

d [mm]	DN [mm]	PN* [bar]	kv-value ($\Delta p=1$ bar) [l/min]	EPDM Code	PTFE/EPDM Code	kg
20	15	10/10*	125	167 645 112	167 645 132	0.451
25	20	10/10*	271	167 645 113	167 645 133	0.812
32	25	10/10*	481	167 645 114	167 645 134	0.974
40	32	10/10*	759	167 645 115	167 645 135	1.553
50	40	10/10*	1263	167 645 116	167 645 136	3.280
63	50	10/10*	1728	167 645 117	167 645 137	3.837

d [mm]	D [mm]	D1_G [inch]	L [mm]	L2 [mm]	H [mm]	H1 [mm]	H2 [mm]	H3 [mm]	H4 [mm]	H5 [mm]	H7 [mm]	M	Lift = Hx [mm]	e [mm]
20	68	1/8	124	25	101	14	12	60	24	16	43	M6	7	1.9
25	96	1/8	144	25	132	18	12	73	25	16	57	M6	10	2.3
32	96	1/8	154	25	143	22	12	84	25	16	57	M6	13	2.9
40	120	1/8	174	45	173	26	15	99	26	26	69	M8	15	3.7
50	150	1/4	194	45	214	32	15	119	36	26	88	M8	19	4.6
63	150	1/4	224	45	226	39	15	132	36	26	88	M8	23	5.8



PROGEF Standard Diaphragm valve DIASTAR Ten FO (Fail safe to open) With backing flanges PP-V metric/BS

Model:

- Material: PP-H
- Double flow rate compared to predecessor
- One housing nut replaces four screws
- Rotating air connection at 90° intervals
- Flat sealing faces/serrated
- Overall length EN 558
- Connecting dimension: ISO 7005 PN 10, EN 1092 PN 10, DIN 2501 PN 10, BS 4504 PN 10

Option:

- Individual configuration of the valve (see diagram)
- Comprehensive range of accessories available

* PN: PTFE

Working Pressure: **one side**

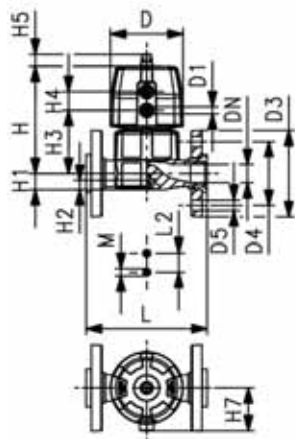

d [mm]	DN [mm]	PN* [bar]	kv-value ($\Delta p=1$ bar) [l/min]	EPDM Code	PTFE/EPDM Code	kg
20	15	10/10*	125	167 647 112	167 647 132	0.634
25	20	10/10*	271	167 647 113	167 647 133	1.060
32	25	10/10*	481	167 647 114	167 647 134	1.322
40	32	10/10*	759	167 647 115	167 647 135	2.089
50	40	10/10*	1263	167 647 116	167 647 136	3.829
63	50	10/10*	1728	167 647 117	167 647 137	4.780

d [mm]	D [mm]	D1_G [inch]	D3 [mm]	D4 [mm]	D5 [mm]	L [mm]	L2 [mm]	H [mm]	H1 [mm]	H2 [mm]	H3 [mm]	H4 [mm]	H5 [mm]	H7 [mm]	M
20	68	1/8	95	65	14	130	25	101	14	12	60	24	16	57	M6
25	96	1/8	105	75	14	150	25	132	18	12	73	25	16	57	M6
32	96	1/8	115	85	14	160	25	143	22	12	84	25	16	69	M6
40	120	1/8	140	100	18	180	45	173	26	15	99	26	26	88	M8
50	150	1/4	150	110	18	200	45	214	32	15	119	36	26	103	M8
63	150	1/4	165	125	18	230	45	226	39	15	132	36	26	103	M8

d [mm]	Lift = Hx [mm]
20	7
25	10
32	13
40	15
50	19
63	23



PROGEF Standard Diaphragm valve DIASTAR Ten FO (Fail safe to open) With backing flanges PP-V Inch ANSI

Model:

- Material: PP-H
- Double flow rate compared to predecessor
- One housing nut replaces four screws
- Rotating air connection at 90° intervals
- Flat sealing faces/serrated
- Connecting dimension: ANSI/ASME B 16.5 class 150, ASTM D 4024, BS 1560, BS EN 1759

Option:

- Individual configuration of the valve (see diagram)
- Comprehensive range of accessories available

* PN: PTFE

Working Pressure: **one side**

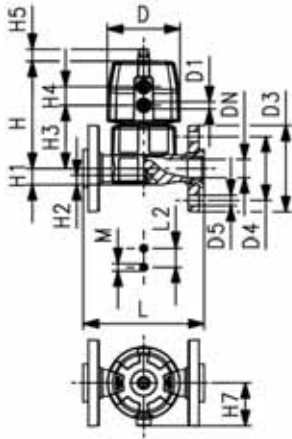

Inch	DN [mm]	PN* [bar]	kv-value ($\Delta p=1$ bar) [l/min]	EPDM Code	PTFE/EPDM Code	kg
1/2	15	10/10*	125	167 647 712	167 647 732	0.634
3/4	20	10/10*	271	167 647 713	167 647 733	1.060
1	25	10/10*	481	167 647 714	167 647 734	1.322
1 1/4	32	10/10*	759	167 647 715	167 647 735	2.089
1 1/2	40	10/10*	1263	167 647 716	167 647 736	3.829
2	50	10/10*	1728	167 647 717	167 647 737	4.780

Inch	D [mm]	D1_G [inch]	D3 [mm]	D4 [mm]	D5 [mm]	L [mm]	L2 [mm]	H [mm]	H1 [mm]	H2 [mm]	H3 [mm]	H4 [mm]	H5 [mm]	H7 [mm]	M
1/2	68	1/8	95	60	16	130	25	101	14	12	60	24	16	57	M6
3/4	96	1/8	105	70	16	150	25	132	18	12	73	25	16	57	M6
1	96	1/8	115	79	16	160	25	143	22	12	84	25	16	69	M6
1 1/4	120	1/8	140	89	16	180	45	173	26	15	99	26	26	88	M8
1 1/2	150	1/4	150	98	16	200	45	214	32	15	119	36	26	103	M8
2	150	1/4	165	121	19	230	45	226	39	15	132	36	26	103	M8

Inch	Lift = Hx [mm]
1/2	7
3/4	10
1	13
1 1/4	15
1 1/2	19
2	23



PROGEF Standard Diaphragm valve DIASTAR Ten FO (Fail safe to open) With fixed flanges PP-H JIS

Model:

- Material: PP-H
- Double flow rate compared to predecessor
- One housing nut replaces four screws
- Rotating air connection at 90° intervals
- Flat sealing faces/serrated
- Connecting dimension: JIS B2238/39 10K

Option:

- Individual configuration of the valve (see diagram)
- Comprehensive range of accessories available

* PN: PTFE

Working Pressure: **one side**

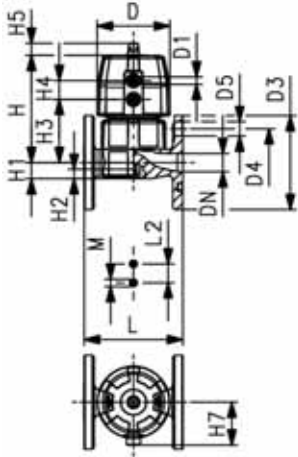

Inch	DN [mm]	PN* [bar]	kv-value ($\Delta p=1$ bar) [l/min]	EPDM Code	PTFE/EPDM Code	kg
1/2	15	10/10*	125	167 647 912	167 647 932	0.578
3/4	20	10/10*	271	167 647 913	167 647 933	0.934
1	25	10/10*	481	167 647 914	167 647 934	1.174
1 1/4	32	10/10*	759	167 647 915	167 647 935	1.891
1 1/2	40	10/10*	1263	167 647 916	167 647 936	3.647
2	50	10/10*	1728	167 647 917	167 647 937	4.290

Inch	D [mm]	D1_G [inch]	D3 [mm]	D4 [mm]	D5 [mm]	L [mm]	L2 [mm]	H [mm]	H1 [mm]	H2 [mm]	H3 [mm]	H4 [mm]	H5 [mm]	H7 [mm]	M
1/2	68	1/8	95	70	15	110	25	101	14	12	60	24	16	57	M6
3/4	96	1/8	100	75	15	120	25	132	18	12	73	25	16	57	M6
1	96	1/8	125	90	19	130	25	143	22	12	84	25	16	69	M6
1 1/4	120	1/8	135	100	19	180	45	173	26	15	99	26	26	88	M8
1 1/2	150	1/4	140	105	19	180	45	214	32	15	119	36	26	103	M8
2	150	1/4	155	120	19	210	45	226	39	15	132	36	26	103	M8

Inch	Lift = Hx [mm]
1/2	7
3/4	10
1	13
1 1/4	15
1 1/2	19
2	23



PROGEF Standard Diaphragm valve type DIASTAR Series 025 FO (Fail safe to open) With fixed flanges PP metric

Model:

- Material: PP-H
- Connecting dimensions: ISO 7005 / EN 1092 / DIN 2501 PN10 / BS4504
- With position indicator / Working pressure: **one side**

* With backing flanges PP-V

** Connecting dimensions DN80 and DN150 metric and Inch ANSI B16.5

d [mm]	DN [mm]	Inch	PN	kv-value ($\Delta p=1$ bar) [l/min]	EPDM Code	PTFE/EPDM Code	kg
* 75	65	2 ½	10	992	199 025 277	199 025 307	13.600
** 90	80	3	10	1700	199 025 278	199 025 308	17.400
110	100	4	6	2700	199 025 279	199 025 309	24.700
** 160	150	6	6	6033	199 025 280	199 025 310	35.000

d [mm]	D [mm]	D1_G [inch]	D2 [mm]	D3[M] [mm]	D4 [mm]	L [mm]	L2 [mm]	L3 [mm]	H [mm]	H1 [mm]	H2 [mm]	H3 [mm]	H4 [mm]	H5 [mm]
* 75	280	¼	185	8	145	290	70		344	148	24	46	100	129
** 90	280	¼	200	12	160	310	120		348	150	24	46	100	129
110	335	¼	225	12	180	350	120		395	176	24	46	100	129
** 160	335	¼	285	12	240	480	100	200	455	237	24	46	100	129

d [mm]	H6 [mm]	H7 [mm]	H9 [mm]	H10 [mm]
* 75	195	298	46	15
** 90	195	302	57	15
110	195	349	69	20
** 160	195	409	108	20

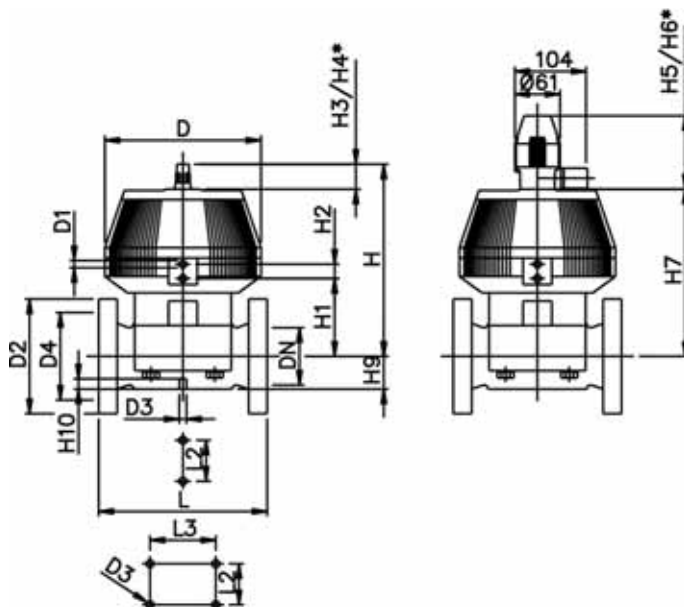



PROGEF Standard Diaphragm valve DIASTAR Ten DA (Double acting) Unions with fusion sockets metric

Model:

- Material: PP-H
- Double flow rate compared to predecessor
- One housing nut replaces four screws
- Rotating air connection at 90° intervals
- For easy installation and removal
- Short overall length

Option:

- Individual configuration of the valve (see diagram)
- Comprehensive range of accessories available

* PN: PTFE

Working Pressure: **one side**

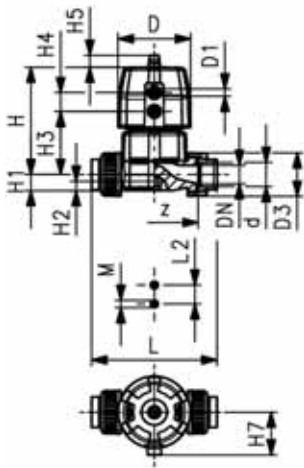

d [mm]	DN [mm]	PN* [bar]	kv-value ($\Delta p=1$ bar) [l/min]	EPDM Code	PTFE/EPDM Code	kg
20	15	10/10*	125	167 654 012	167 654 032	0.499
25	20	10/10*	271	167 654 013	167 654 033	0.883
32	25	10/10*	481	167 654 014	167 654 034	1.077
40	32	10/10*	759	167 654 015	167 654 035	1.666
50	40	10/10*	1263	167 654 016	167 654 036	2.783
63	50	10/10*	1728	167 654 017	167 654 037	3.516

d [mm]	D [mm]	D1_G [inch]	L [mm]	L2 [mm]	H [mm]	H1 [mm]	H2 [mm]	H3 [mm]	H4 [mm]	H5 [mm]	H7 [mm]	M	z [mm]	Lift = Hx [mm]
20	68	1/8	128	25	101	14	12	60	24	16	43	M6	100	7
25	96	1/8	152	25	132	18	12	73	25	16	57	M6	118	10
32	96	1/8	166	25	143	22	12	84	25	16	57	M6	126	13
40	120	1/8	192	45	173	26	15	99	26	26	69	M8	144	15
50	150	1/4	222	45	214	32	15	119	36	26	88	M8	164	19
63	150	1/4	266	45	226	39	15	132	36	26	88	M8	194	23



PROGEF Standard Diaphragm valve DIASTAR Ten DA (Double acting) Unions with butt fusion spigots SDR11 metric

Model:

- Material: PP-H
- Double flow rate compared to predecessor
- One housing nut replaces four screws
- Rotating air connection at 90° intervals
- For easy installation and removal
- Short overall length

Option:

- Individual configuration of the valve (see diagram)
- Comprehensive range of accessories available

* PN: PTFE

Working Pressure: **one side**

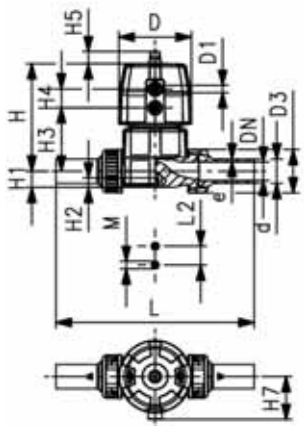

d [mm]	DN [mm]	PN* [bar]	kv-value ($\Delta p=1$ bar) [l/min]	EPDM Code	PTFE/EPDM Code	kg
20	15	10/10*	125	167 654 112	167 654 132	0.507
25	20	10/10*	271	167 654 113	167 654 133	0.895
32	25	10/10*	481	167 654 114	167 654 134	1.097
40	32	10/10*	759	167 654 115	167 654 135	1.698
50	40	10/10*	1263	167 654 116	167 654 136	2.791
63	50	10/10*	1728	167 654 117	167 654 137	3.530

table continued next page

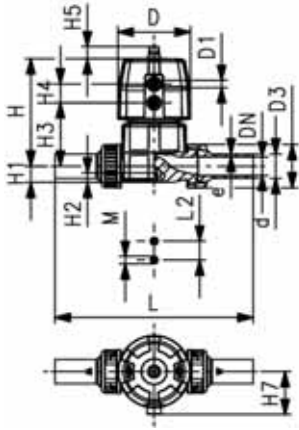

d [mm]	D [mm]	D1_G [inch]	L [mm]	L2 [mm]	H [mm]	H1 [mm]	H2 [mm]	H3 [mm]	H4 [mm]	H5 [mm]	H7 [mm]	M	Lift = Hx [mm]	e [mm]
20	68	1/8	196	25	101	14	12	60	24	16	43	M6	7	1.9
25	96	1/8	221	25	132	18	12	73	25	16	57	M6	10	2.3
32	96	1/8	234	25	143	22	12	84	25	16	57	M6	13	2.9
40	120	1/8	260	45	173	26	15	99	26	26	69	M8	15	3.7
50	150	1/4	284	45	214	32	15	119	36	26	69	M8	19	4.6
63	150	1/4	321	45	226	39	15	132	36	26	69	M8	23	5.8



PROGEF Standard Diaphragm valve DIASTAR Ten DA (Double acting) With socket fusion spigots metric

Model:

- Material: PP-H
- Double flow rate compared to predecessor
- One housing nut replaces four screws
- Rotating air connection at 90° intervals
- Overall length EN 558

Option:

- Individual configuration of the valve (see diagram)
- Comprehensive range of accessories available

* PN: PTFE

Working Pressure: **one side**

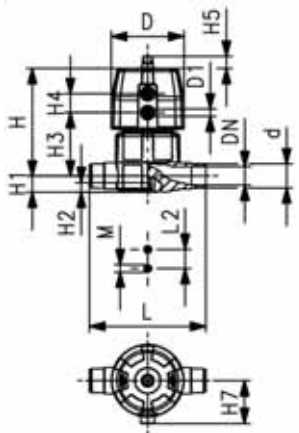

d [mm]	DN [mm]	PN* [bar]	kv-value ($\Delta p=1$ bar) [l/min]	EPDM Code	PTFE/EPDM Code	kg
20	15	10/10*	125	167 655 012	167 655 032	0.436
25	20	10/10*	271	167 655 013	167 655 033	0.780
32	25	10/10*	481	167 655 014	167 655 034	0.946
40	32	10/10*	759	167 655 015	167 655 035	1.497
50	40	10/10*	1263	167 655 016	167 655 036	2.535
63	50	10/10*	1728	167 655 017	167 655 037	3.090

d [mm]	D [mm]	D1_G [inch]	L [mm]	L2 [mm]	H [mm]	H1 [mm]	H2 [mm]	H3 [mm]	H4 [mm]	H5 [mm]	H7 [mm]	M	Lift = Hx [mm]
20	68	1/8	124	25	101	14	12	60	24	16	43	M6	7
25	96	1/8	144	25	132	18	12	73	25	16	57	M6	10
32	96	1/8	154	25	143	22	12	84	25	16	57	M6	13
40	120	1/8	174	45	173	26	15	99	26	26	69	M8	15
50	150	1/4	194	45	214	32	15	119	36	26	88	M8	19
63	150	1/4	224	45	226	39	15	132	36	26	88	M8	23



PROGEF Standard Diaphragm valve DIASTAR Ten DA (Double acting) With butt fusion spigots SDR11 metric

Model:

- Material: PP-H
- Double flow rate compared to predecessor
- One housing nut replaces four screws
- Rotating air connection at 90° intervals

Option:

- Individual configuration of the valve (see diagram)
- Comprehensive range of accessories available

* PN: PTFE

Working Pressure: **one side**

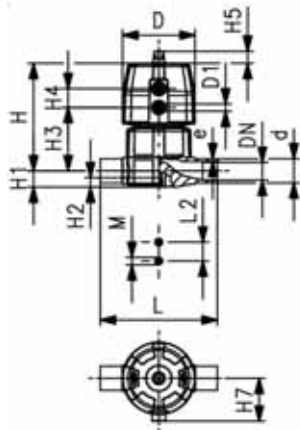

d [mm]	DN [mm]	PN* [bar]	kv-value ($\Delta p=1$ bar) [l/min]	EPDM Code	PTFE/EPDM Code	kg
20	15	10/10*	125	167 655 112	167 655 132	0.435
25	20	10/10*	271	167 655 113	167 655 133	0.776
32	25	10/10*	481	167 655 114	167 655 134	0.944
40	32	10/10*	759	167 655 115	167 655 135	1.493
50	40	10/10*	1263	167 655 116	167 655 136	2.530
63	50	10/10*	1728	167 655 117	167 655 137	3.087

d [mm]	D [mm]	D1_G [inch]	L [mm]	L2 [mm]	H [mm]	H1 [mm]	H2 [mm]	H3 [mm]	H4 [mm]	H5 [mm]	H7 [mm]	M	Lift = Hx [mm]	e [mm]
20	68	1/8	124	25	101	14	12	60	24	16	43	M6	7	1.9
25	96	1/8	144	25	132	18	12	73	25	16	57	M6	10	2.3
32	96	1/8	154	25	143	22	12	84	25	16	57	M6	13	2.9
40	120	1/8	174	45	173	26	15	99	26	26	69	M8	15	3.7
50	150	1/4	194	45	214	32	15	119	36	26	88	M8	19	4.6
63	150	1/4	224	45	226	39	15	132	36	26	88	M8	23	5.8



PROGEF Standard Diaphragm valve DIASTAR Ten DA (Double acting) With backing flanges PP-V metric/BS

Model:

- Material: PP-H
- Double flow rate compared to predecessor
- One housing nut replaces four screws
- Rotating air connection at 90° intervals
- Flat sealing faces/serrated
- Overall length EN 558
- Connecting dimension: ISO 7005 PN 10, EN 1092 PN 10, DIN 2501 PN 10, BS 4504 PN 10

Option:

- Individual configuration of the valve (see diagram)
- Comprehensive range of accessories available

* PN: PTFE

Working Pressure: **one side**

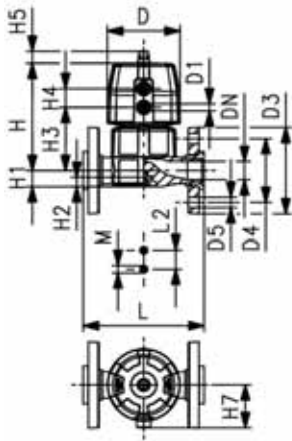

d [mm]	DN [mm]	PN* [bar]	kv-value ($\Delta p=1$ bar) [l/min]	EPDM Code	PTFE/EPDM Code	kg
20	15	10/10*	125	167 657 112	167 657 132	0.618
25	20	10/10*	271	167 657 113	167 657 133	1.024
32	25	10/10*	481	167 657 114	167 657 134	1.292
40	32	10/10*	759	167 657 115	167 657 135	2.029
50	40	10/10*	1263	167 657 116	167 657 136	3.079
63	50	10/10*	1728	167 657 117	167 657 137	4.030

d [mm]	D [mm]	D1_G [inch]	D3 [mm]	D4 [mm]	D5 [mm]	L [mm]	L2 [mm]	H [mm]	H1 [mm]	H2 [mm]	H3 [mm]	H4 [mm]	H5 [mm]	H7 [mm]	M
20	68	1/8	95	65	14	130	25	101	14	12	60	24	16	57	M6
25	96	1/8	105	75	14	150	25	132	18	12	73	25	16	57	M6
32	96	1/8	115	85	14	160	25	143	22	12	84	25	16	69	M6
40	120	1/8	140	100	18	180	45	173	26	15	99	26	26	88	M8
50	150	1/4	150	110	18	200	45	214	32	15	119	36	26	103	M8
63	150	1/4	165	125	18	230	45	226	39	15	132	36	26	103	M8

d [mm]	Lift = Hx [mm]
20	7
25	10
32	13
40	15
50	19
63	23



PROGEF Standard Diaphragm valve DIASTAR Ten DA (Double acting) With backing flanges PP-V Inch ANSI

Model:

- Material: PP-H
- Double flow rate compared to predecessor
- One housing nut replaces four screws
- Rotating air connection at 90° intervals
- Flat sealing faces/serrated
- Connecting dimension: ANSI/ASME B 16.5 class 150, ASTM D 4024, BS 1560, BS EN 1759

Option:

- Individual configuration of the valve (see diagram)
- Comprehensive range of accessories available

* PN: PTFE

Working Pressure: **one side**

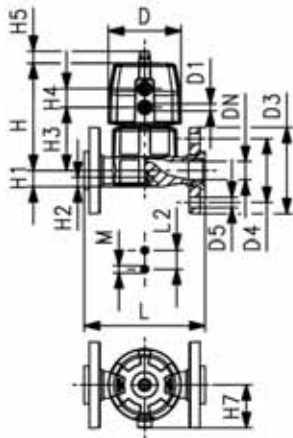

Inch	DN [mm]	PN* [bar]	kv-value ($\Delta p=1$ bar) [l/min]	EPDM Code	PTFE/EPDM Code	kg
½	15	10/10*	125	167 657 712	167 657 732	0.618
¾	20	10/10*	271	167 657 713	167 657 733	1.024
1	25	10/10*	481	167 657 714	167 657 734	1.292
1 ¼	32	10/10*	759	167 657 715	167 657 735	2.029
1 ½	40	10/10*	1263	167 657 716	167 657 736	3.079
2	50	10/10*	1728	167 657 717	167 657 737	4.030

Inch	D [mm]	D1_G [inch]	D3 [mm]	D4 [mm]	D5 [mm]	L [mm]	L2 [mm]	H [mm]	H1 [mm]	H2 [mm]	H3 [mm]	H4 [mm]	H5 [mm]	H7 [mm]	M
½	68	⅜	95	60	16	130	25	101	14	12	60	24	16	57	M6
¾	96	⅜	105	70	16	150	25	132	18	12	73	25	16	57	M6
1	96	⅜	115	79	16	160	25	143	22	12	84	25	16	69	M6
1 ¼	120	⅜	140	89	16	180	45	173	26	15	99	26	26	88	M8
1 ½	150	¼	150	98	16	200	45	214	32	15	119	36	26	103	M8
2	150	¼	165	121	19	230	45	226	39	15	132	36	26	103	M8

Inch	Lift = Hx [mm]
½	7
¾	10
1	13
1 ¼	15
1 ½	19
2	23



PROGEF Standard Diaphragm valve DIASTAR Ten DA (Double acting) With fixed flanges PP-H JIS

Model:

- Material: PP-H
- Double flow rate compared to predecessor
- One housing nut replaces four screws
- Rotating air connection at 90° intervals
- Flat sealing faces/serrated
- Connecting dimension: JIS B2238/39 10K

Option:

- Individual configuration of the valve (see diagram)
- Comprehensive range of accessories available

* PN: PTFE

Working Pressure: **one side**

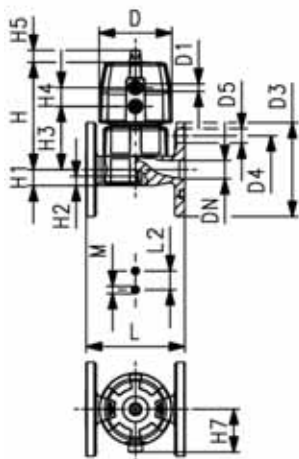

Inch	DN [mm]	PN* [bar]	kv-value ($\Delta p=1$ bar) [l/min]	EPDM Code	PTFE/EPDM Code	kg
1/2	15	10/10*	125	167 657 912	167 657 932	0.562
3/4	20	10/10*	271	167 657 913	167 657 933	0.898
1	25	10/10*	481	167 657 914	167 657 934	1.144
1 1/4	32	10/10*	759	167 657 915	167 657 935	1.831
1 1/2	40	10/10*	1263	167 657 916	167 657 936	2.897
2	50	10/10*	1728	167 657 917	167 657 937	3.540

Inch	D [mm]	D1_G [inch]	D3 [mm]	D4 [mm]	D5 [mm]	L [mm]	L2 [mm]	H [mm]	H1 [mm]	H2 [mm]	H3 [mm]	H4 [mm]	H5 [mm]	H7 [mm]	M
1/2	68	1/8	95	70	15	110	25	101	14	12	60	24	16	57	M6
3/4	96	1/8	100	75	15	120	25	132	18	12	73	25	16	57	M6
1	96	1/8	125	90	19	130	25	143	22	12	84	25	16	69	M6
1 1/4	120	1/8	135	100	19	180	45	173	26	15	99	26	26	88	M8
1 1/2	150	1/4	140	105	19	180	45	214	32	15	119	36	26	103	M8
2	150	1/4	155	120	19	210	45	226	39	15	132	36	26	103	M8

Inch	Lift = Hx [mm]
1/2	7
3/4	10
1	13
1 1/4	15
1 1/2	19
2	23



PROGEF Standard Diaphragm valve type DIASTAR Series 025 DA (Double acting) With fixed flanges PP metric

Model:

- Material: PP-H
- Connecting dimensions: ISO 7005 / EN 1092 / DIN 2501 PN10 / BS4504
- With position indicator / Working pressure: **one side**

* With backing flanges PP-V

** Connecting dimensions DN80 and DN150 metric and Inch ANSI B16.5

d [mm]	DN [mm]	Inch	PN	kv-value ($\Delta p=1$ bar) [l/min]	EPDM Code	PTFE/EPDM Code	kg
* 75	65	2 ½	10	992	199 025 287	199 025 317	13.600
** 90	80	3	10	1700	199 025 288	199 025 318	17.400
110	100	4	6	2700	199 025 289	199 025 319	24.700
** 160	150	6	6	6033	199 025 290	199 025 320	35.000

d [mm]	D [mm]	D1_G [inch]	D2 [mm]	D3[M] [mm]	D4 [mm]	L [mm]	L2 [mm]	L3 [mm]	H [mm]	H1 [mm]	H2 [mm]	H3 [mm]	H4 [mm]	H5 [mm]
* 75	280	¼	185	8	145	290	70		344	148	24	46	100	129
** 90	280	¼	200	12	160	310	120		348	150	24	46	100	129
110	335	¼	225	12	180	350	120		395	176	24	46	100	129
** 160	335	¼	285	12	240	480	100	200	455	237	24	46	100	129

d [mm]	H6 [mm]	H7 [mm]	H9 [mm]	H10 [mm]
* 75	195	298	46	15
** 90	195	302	57	15
110	195	349	69	20
** 160	195	409	108	20

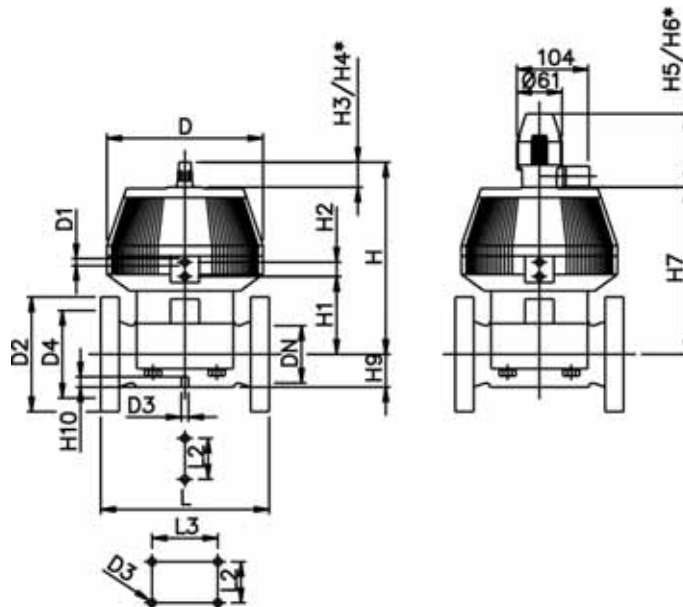



PROGEF Standard Diaphragm valve DIASTAR TenPlus FC (Fail safe to close) Unions with fusion sockets metric

Model:

- Material: PP-H
- One housing nut replaces four screws
- Rotating air connection at 90° intervals
- Double flow rate compared to predecessor
- Short overall length
- For easy installation and removal

Option:

- Individual configuration of the valve (see diagram)
- Comprehensive range of accessories available

* PN: PTFE

Working Pressure: **both sides**

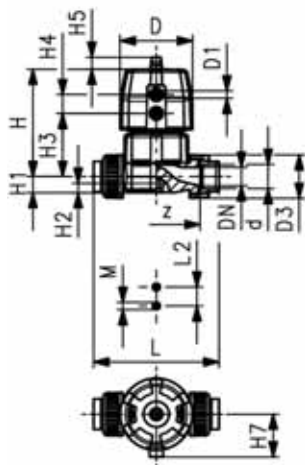

d [mm]	DN [mm]	PN* [bar]	kv-value ($\Delta p=1$ bar) [l/min]	EPDM Code	FPM Code	PTFE/EPDM Code	PTFE/FPM Code
20	15	10/10*	125	167 684 012	167 684 062	167 684 032	167 684 052
25	20	10/10*	271	167 684 013	167 684 063	167 684 033	167 684 053
32	25	10/10*	481	167 684 014	167 684 064	167 684 034	167 684 054
40	32	10/10*	759	167 684 015	167 684 065	167 684 035	167 684 055
50	40	10/10*	1263	167 684 016	167 684 066	167 684 036	167 684 056
63	50	10/10*	1728	167 684 017	167 684 067	167 684 037	167 684 057

d [mm]	D [mm]	D1_G [inch]	L [mm]	L2 [mm]	H [mm]	H1 [mm]	H2 [mm]	H3 [mm]	H4 [mm]	H5 [mm]	H7 [mm]	M	z [mm]	Lift = Hx [mm]
20	96	1/8	128	25	127	14	12	68	25	16	57	M6	100	7
25	96	1/8	152	25	132	18	12	73	25	16	57	M6	118	10
32	120	1/8	166	25	167	22	12	93	26	26	69	M6	126	13
40	150	1/4	192	45	196	26	15	101	36	26	88	M8	144	15
50	180	1/4	222	45	239	32	15	124	37	26	103	M8	164	19
63	180	1/4	266	45	251	39	15	137	37	26	103	M8	194	23



PROGEF Standard Diaphragm valve DIASTAR TenPlus FC (Fail safe to close) Unions with fusion sockets PE80 metric

Model:

- Material: PP-H
- One housing nut replaces four screws
- Rotating air connection at 90° intervals
- Double flow rate compared to predecessor
- Short overall length
- Double flow rate compared to predecessor
- For easy installation and removal
- Short overall length

Option:

- Individual configuration of the valve (see diagram)
- Comprehensive range of accessories available

* PN: PTFE

Working Pressure: **both sides**

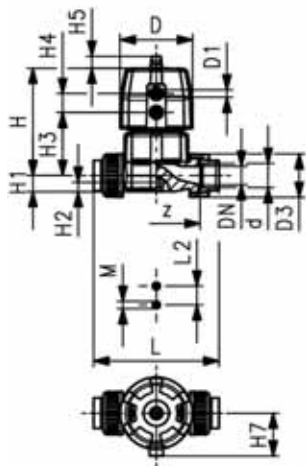

d [mm]	DN [mm]	PN* [bar]	kv-value ($\Delta p=1$ bar) [l/min]	EPDM Code	PTFE/EPDM Code	kg
20	15	10/10*	156	167 684 212	167 684 232	0.965
25	20	10/10*	276	167 684 213	167 684 233	1.096
32	25	10/10*	561	167 684 214	167 684 234	1.883
40	32	10/10*	684	167 684 215	167 684 235	3.158
50	40	10/10*	950	167 684 216	167 684 236	4.985
63	50	10/10*	1425	167 684 217	167 684 237	5.683

d [mm]	D [mm]	D1_G [inch]	L [mm]	L2 [mm]	H [mm]	H1 [mm]	H2 [mm]	H3 [mm]	H4 [mm]	H5 [mm]	H7 [mm]	M	z [mm]	Lift = Hx [mm]
20	96	1/8	128	25	127	14	12	68	25	16	57	M6	100	7
25	96	1/8	150	25	132	18	12	73	25	16	57	M6	118	10
32	120	1/8	162	25	167	22	12	93	26	26	69	M6	126	13
40	150	1/4	184	45	196	26	15	101	36	26	88	M8	144	15
50	180	1/4	210	45	239	32	15	124	37	26	103	M8	164	19
63	180	1/4	248	45	251	39	15	137	37	26	103	M8	194	23



PROGEF Standard Diaphragm valve DIASTAR TenPlus FC (Fail safe to close) Unions with butt fusion spigots SDR11 metric

Model:

- Material: PP-H
- One housing nut replaces four screws
- Rotating air connection at 90° intervals
- Double flow rate compared to predecessor
- Short overall length
- For easy installation and removal

Option:

- Individual configuration of the valve (see diagram)
- Comprehensive range of accessories available

* PN: PTFE

Working Pressure: **both sides**

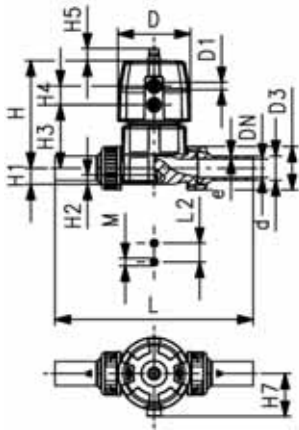

d [mm]	DN [mm]	PN* [bar]	kv-value ($\Delta p=1$ bar) [l/min]	EPDM Code	FPM Code	PTFE/EPDM Code	PTFE/FPM Code
20	15	10/10*	125	167 684 112	167 684 162	167 684 132	167 684 152
25	20	10/10*	271	167 684 113	167 684 163	167 684 133	167 684 153
32	25	10/10*	481	167 684 114	167 684 164	167 684 134	167 684 154
40	32	10/10*	759	167 684 115	167 684 165	167 684 135	167 684 155
50	40	10/10*	1263	167 684 116	167 684 166	167 684 136	167 684 156
63	50	10/10*	1728	167 684 117	167 684 167	167 684 137	167 684 157

d [mm]	D [mm]	D1_G [inch]	L [mm]	L2 [mm]	H [mm]	H1 [mm]	H2 [mm]	H3 [mm]	H4 [mm]	H5 [mm]	H7 [mm]	M	Lift = Hx [mm]	e [mm]
20	96	1/8	196	25	127	14	12	68	25	16	57	M6	7	1.9
25	96	1/8	221	25	132	18	12	73	25	16	57	M6	10	2.3
32	120	1/8	234	25	167	22	12	93	26	26	69	M6	13	2.9
40	150	1/4	260	45	196	26	15	101	36	26	88	M8	15	3.7
50	180	1/4	284	45	239	32	15	124	37	26	103	M8	19	4.6
63	180	1/4	321	45	251	39	15	137	37	26	103	M8	23	5.8



PROGEF Standard Diaphragm valve DIASTAR TenPlus FC (Fail safe to close) Unions with butt fusion spigots PE100 SDR11 metric

Model:

- Material: PP-H
- One housing nut replaces four screws
- Rotating air connection at 90° intervals
- Double flow rate compared to predecessor
- Short overall length
- Double flow rate compared to predecessor
- For easy installation and removal
- Short overall length

Option:

- Individual configuration of the valve (see diagram)
- Comprehensive range of accessories available

* PN: PTFE

Working Pressure: **both sides**

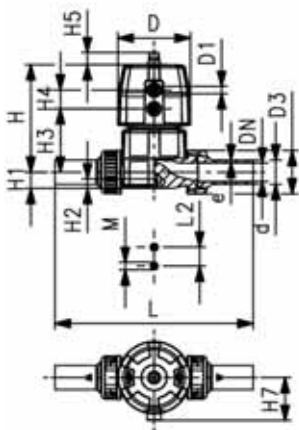

d [mm]	DN [mm]	PN* [bar]	kv-value ($\Delta p=1$ bar) [l/min]	EPDM Code	PTFE/EPDM Code	kg
20	15	10/10*	156	167 684 312	167 684 332	0.975
25	20	10/10*	276	167 684 313	167 684 333	1.108
32	25	10/10*	561	167 684 314	167 684 334	1.907

table continued next page

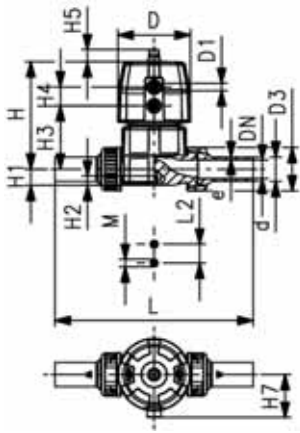

d [mm]	DN [mm]	PN* [bar]	kv-value ($\Delta p=1$ bar) [l/min]	EPDM Code	PTFE/EPDM Code	kg
40	32	10/10*	684	167 684 315	167 684 335	3.196
50	40	10/10*	950	167 684 316	167 684 336	5.055
63	50	10/10*	1425	167 684 317	167 684 337	5.793

d [mm]	D [mm]	D1_G [inch]	L [mm]	L2 [mm]	H [mm]	H1 [mm]	H2 [mm]	H3 [mm]	H4 [mm]	H5 [mm]	H7 [mm]	M	Lift = Hx [mm]	e [mm]
20	96	1/8	196	25	127	14	12	68	25	16	57	M6	7	1.9
25	96	1/8	221	25	132	18	12	73	25	16	57	M6	10	2.3
32	120	1/8	234	25	167	22	12	93	26	26	69	M6	13	3.0
40	150	1/4	260	45	196	26	15	101	36	26	88	M8	15	3.7
50	180	1/4	284	45	239	32	15	124	37	26	103	M8	19	4.6
63	180	1/4	321	45	251	39	15	137	37	26	103	M8	23	5.8



PROGEF Standard Diaphragm valve DIASTAR TenPlus FC (Fail safe to close) With socket fusion spigots metric

Model:

- Material: PP-H
- One housing nut replaces four screws
- Rotating air connection at 90° intervals
- Double flow rate compared to predecessor
- Short overall length
- Double flow rate compared to predecessor
- Overall length EN 558

Option:

- Individual configuration of the valve (see diagram)
- Comprehensive range of accessories available

* PN: PTFE

Working Pressure: **both sides**

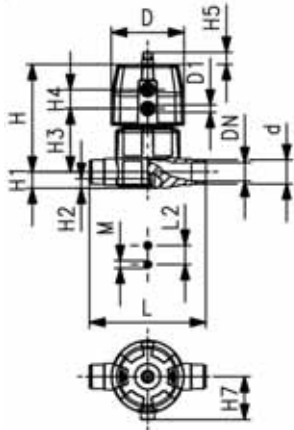

d [mm]	DN [mm]	PN* [bar]	kv-value ($\Delta p=1$ bar) [l/min]	EPDM Code	PTFE/EPDM Code	kg
20	15	10/10*	125	167 685 012	167 685 032	0.902
25	20	10/10*	271	167 685 013	167 685 033	0.990
32	25	10/10*	481	167 685 014	167 685 034	1.750
40	32	10/10*	759	167 685 015	167 685 035	2.987
50	40	10/10*	1263	167 685 016	167 685 036	4.650
63	50	10/10*	1728	167 685 017	167 685 037	5.337

d [mm]	D [mm]	D1_G [inch]	L [mm]	L2 [mm]	H [mm]	H1 [mm]	H2 [mm]	H3 [mm]	H4 [mm]	H5 [mm]	H7 [mm]	M	Lift = Hx [mm]	e [mm]
20	96	1/8	124	25	127	14	12	68	25	16	57	M6	7	1.9
25	96	1/8	144	25	132	18	12	73	25	16	57	M6	10	2.3
32	120	1/8	154	25	167	22	12	93	26	26	69	M6	13	2.9
40	150	1/4	174	45	196	26	15	101	36	26	88	M8	15	3.7
50	180	1/4	194	45	239	32	15	124	37	26	103	M8	19	4.6
63	180	1/4	224	45	251	39	15	137	37	26	103	M8	23	5.8



PROGEF Standard Diaphragm valve DIASTAR TenPlus FC (Fail safe to close) With butt fusion spigots SDR11 metric

Model:

- Material: PP-H
- One housing nut replaces four screws
- Rotating air connection at 90° intervals
- Double flow rate compared to predecessor
- Short overall length
- Double flow rate compared to predecessor

Option:

- Individual configuration of the valve (see diagram)
- Comprehensive range of accessories available

* PN: PTFE

Working Pressure: **both sides**

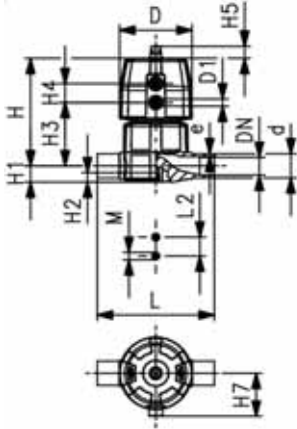

d [mm]	DN [mm]	PN* [bar]	kv-value ($\Delta p=1$ bar) [l/min]	EPDM Code	PTFE/EPDM Code	kg
20	15	10/10*	125	167 685 112	167 685 132	0.901
25	20	10/10*	271	167 685 113	167 685 133	0.986
32	25	10/10*	481	167 685 114	167 685 134	1.748
40	32	10/10*	759	167 685 115	167 685 135	2.983
50	40	10/10*	1263	167 685 116	167 685 136	4.778
63	50	10/10*	1728	167 685 117	167 685 137	5.334

d [mm]	D [mm]	D1_G [inch]	L [mm]	L2 [mm]	H [mm]	H1 [mm]	H2 [mm]	H3 [mm]	H4 [mm]	H5 [mm]	H7 [mm]	M	Lift = Hx [mm]	e [mm]
20	96	1/8	124	25	127	14	12	68	25	16	57	M6	7	1.9
25	96	1/8	144	25	132	18	12	73	25	16	57	M6	10	2.3
32	120	1/8	154	25	167	22	12	93	26	26	69	M6	13	2.9
40	150	1/4	174	45	196	26	15	101	36	26	88	M8	15	3.7
50	180	1/4	194	45	239	32	15	124	37	26	103	M8	19	4.6
63	180	1/4	224	45	251	39	15	137	37	26	103	M8	23	5.8



PROGEF Standard Diaphragm valve DIASTAR TenPlus FC (Fail safe to close) With backing flanges PP-V metric/BS

Model:

- Material: PP-H
- One housing nut replaces four screws
- Rotating air connection at 90° intervals
- Double flow rate compared to predecessor
- Short overall length
- Double flow rate compared to predecessor
- Flat sealing faces/serrated
- Overall length EN 558
- Connecting dimension: ISO 7005 PN 10, EN 1092 PN 10, DIN 2501 PN 10, BS 4504 PN 10

Option:

- Individual configuration of the valve (see diagram)
- Comprehensive range of accessories available

* PN: PTFE

Working Pressure: **both sides**

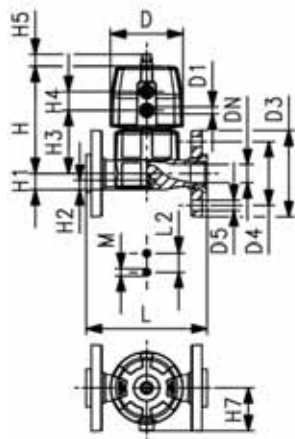

d [mm]	DN [mm]	PN* [bar]	kv-value ($\Delta p=1$ bar) [l/min]	EPDM Code	FPM Code	PTFE/EPDM Code
20	15	10/10*	125	167 687 112	167 687 162	167 687 132
25	20	10/10*	271	167 687 113	167 687 163	167 687 133
32	25	10/10*	481	167 687 114	167 687 164	167 687 134
40	32	10/10*	759	167 687 115	167 687 165	167 687 135
50	40	10/10*	1263	167 687 116	167 687 166	167 687 136
63	50	10/10*	1728	167 687 117	167 687 167	167 687 137

d [mm]	DN [mm]	PN* [bar]	kv-value ($\Delta p=1$ bar) [l/min]	PTFE/FPM Code	kg
20	15	10/10*	125	167 687 152	1.103
25	20	10/10*	271	167 687 153	1.276
32	25	10/10*	481	167 687 154	2.096
40	32	10/10*	759	167 687 155	3.350
50	40	10/10*	1263	167 687 156	5.327
63	50	10/10*	1728	167 687 157	6.678

d [mm]	D [mm]	D1_G [inch]	D3 [mm]	D4 [mm]	D5 [mm]	L [mm]	L2 [mm]	H [mm]	H1 [mm]	H2 [mm]	H3 [mm]	H4 [mm]	H5 [mm]	H7 [mm]	M
20	96	1/8	95	65	14	130	25	127	14	12	68	25	16	57	M6
25	96	1/8	105	75	14	150	25	132	18	12	73	25	16	57	M6
32	120	1/8	115	85	14	160	25	167	22	12	93	26	26	69	M6
40	150	1/4	140	100	18	180	45	196	26	15	101	36	26	88	M8
50	180	1/4	150	110	18	200	45	239	32	15	124	37	26	103	M8
63	180	1/4	165	125	18	230	45	251	39	15	137	37	26	103	M8

d [mm]	Lift = Hx [mm]
20	7
25	10
32	13
40	15
50	19
63	23



PROGEF Standard Diaphragm valve DIASTAR TenPlus FC (Fail safe to close) With butt fusion spigots SDR11 metric

Model:

- Material: PP-H
- One housing nut replaces four screws
- Rotating air connection at 90° intervals
- Double flow rate compared to predecessor
- Short overall length
- Smallest possible dead space

Option:

- Individual configuration of the valve (see diagram)
- Comprehensive range of accessories available

* PN: PTFE

Working Pressure: **both sides**

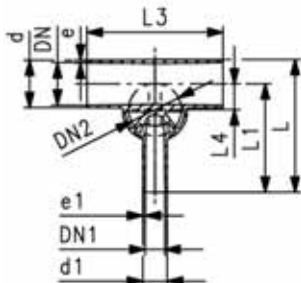
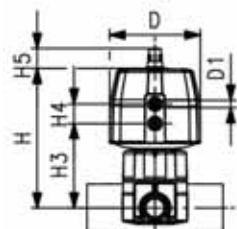

d [mm]	d1 [mm]	Valve Size d [mm]	DN [mm]	DN1 [mm]	DN2 [mm]	PN* [bar]	kv-value ($\Delta p=1$ bar) [l/min]	EPDM Code	PTFE/EPDM Code
20	20	20	15	15	15	10/10*	57	167 689 101	167 689 301
25	20	25	20	15	20	10/10*	89	167 689 103	167 689 303
25	25	25	20	20	20	10/10*	118	167 689 104	167 689 304
32	20	25	25	15	20	10/10*	80	167 689 107	167 689 307
32	25	25	25	20	20	10/10*	105	167 689 108	167 689 308
32	32	32	25	25	25	10/10*	231	167 689 109	167 689 309
40	20	32	32	15	25	10/10*	85	167 689 112	167 689 312
50	20	25	40	15	20	10/10*	86	167 689 118	167 689 318
50	25	32	40	20	25	10/10*	160	167 689 119	167 689 319
50	32	32	40	25	25	10/10*	206	167 689 120	167 689 320
63	20	25	50	15	20	10/10*	84	167 689 125	167 689 325
63	25	32	50	20	25	10/10*	150	167 689 126	167 689 326
63	32	32	50	25	25	10/10*	184	167 689 127	167 689 327

d [mm]	D [mm]	D1 [inch]	L [mm]	L1 [mm]	L3 [mm]	L4 [mm]	H [mm]	H3 [mm]	H4 [mm]	H5 [mm]	Lift = Hx [mm]	e [mm]	e1 [mm]
20	96	1/8	117	96	162	12	130	71	25	16	7	1.9	1.9
25	96	1/8	133	108	162	16	131	72	25	16	10	2.3	1.9
25	96	1/8	133	108	162	16	131	72	25	16	10	2.3	2.3
32	96	1/8	142	120	162	19	135	76	25	16	10	2.9	1.9
32	96	1/8	142	120	162	19	135	76	25	16	10	2.9	2.3
32	120	1/8	145	120	160	19	167	93	26	26	13	2.9	2.9
40	120	1/8	149	128	180	23	175	101	26	26	13	3.7	1.9
50	96	1/8	160	134	180	27	148	90	25	16	10	4.6	1.9
50	120	1/8	160	134	180	28	180	106	26	26	13	4.6	2.3
50	120	1/8	160	134	180	28	180	106	26	26	13	4.6	2.9
63	96	1/8	177	144	180	33	155	96	25	26	10	5.8	1.9
63	120	1/8	177	144	180	35	187	113	26	16	13	5.8	2.3
63	120	1/8	177	144	180	35	187	113	26	26	13	5.8	2.9

Butterfly Valves Electric

Butterfly valve type 140 PP-H 100-230V With manual override



Model:

- Connecting dimension: ISO 7005 PN 10, EN 1092 PN 10, DIN 2501 PN 10, ANSI/ASME B 16.5 Class 150, BS 1560: 1989, BS 4504, JIS B 2220
- Voltage 100-230 V, 50-60 Hz
- Control time 15 s/90°<) EA31
- Control time 25s/90°<) EA42
- Control range 90°<)
- Actuator with integrated emergency manual override standard
- Material: PP-H
- Overall length according to EN 558, ISO 5752

d [mm]	DN [mm]	Inch	PN	kv-value ($\Delta p=1$ bar) [l/min]	EPDM Code	FPM Code	PTFE Code	kg
63	50	2	10	1470	199 140 322	199 140 342	199 140 842	6.002
75	65	2 ½	10	2200	199 140 323	199 140 343	199 140 843	5.694
90	80	3	10	3000	199 140 324	199 140 344	199 140 844	5.822
110	100	4	10	6500	199 140 325	199 140 345	199 140 845	6.327
140	125	5	10	11500	199 140 326	199 140 346	199 140 846	7.174
160	150	6	10	16600	199 140 327	199 140 347	199 140 847	9.604
225	200	8	10	39600	199 140 328	199 140 348	199 140 848	13.271

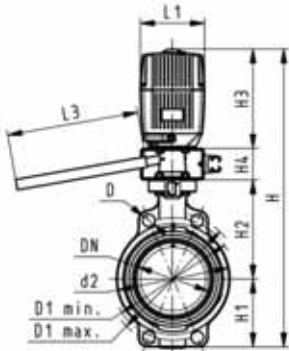

d [mm]	Actuator unit type	D [mm]	D1 min. [mm]	D1 max. [mm]	d2 [mm]	H [mm]	H1 [mm]	H2 [mm]	H3 [mm]	H4 [mm]	L [mm]	L1 [mm]	L2 [mm]
63	EA-31	19	120.0	125.0	104	460	77	134	188	60	45	122	180
75	EA-31	19	139.7	145.0	115	473	83	140	188	60	46	122	180
90	EA-31	19	150.0	160.0	131	488	89	146	188	60	49	122	180
110	EA-31	19	175.0	190.5	161	520	104	167	188	60	56	122	180
140	EA-31	23	210.0	215.9	187	547	117	181	188	60	64	122	180
160	EA-31	24	241.3	241.3	215	568	130	189	188	60	72	122	180
225	EA-42	23	290.0	295.0	267	635	158	210	208	60	73	122	180

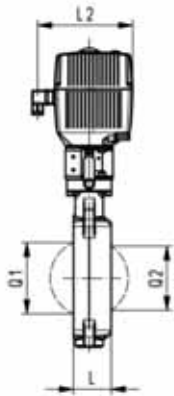

d [mm]	L3 [mm]	Q1 [mm]	Q2 [mm]
63	250	40	
75	250	54	35
90	250	67	50
110	250	88	74
140	250	113	97
160	250	139	123
225	250	178	169



Butterfly valve type 140 PP-H 100-230V Without manual override

Model:

- Connecting dimension: ISO 7005 PN 10, EN 1092 PN 10, DIN 2501 PN 10, ANSI/ASME B 16.5 Class 150, BS 1560: 1989, BS 4504, JIS B 2220
- Voltage 100-230 V, 50-60 Hz
- Control time 15 s/90°<) EA31
- Control time 25s/90°<) EA42
- Control range 90°<)
- Actuator with integrated emergency manual override standard
- Material: PP-H, DN350-DN600 material PP-R
- Up to DN 300: Overall length according to EN558 (DN 50-200: line 25, DN250, 300 line 16), ISO 5752
- For DN350-DN600 electric actuator from Valpes is equipped, various options available

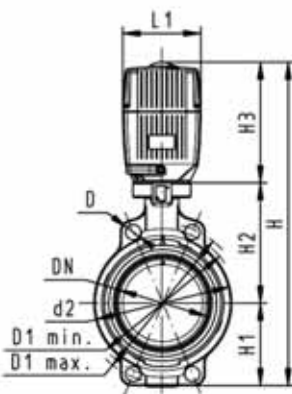

d [mm]	DN [mm]	Inch	PN	kv-value ($\Delta p=1$ bar) [l/min]	EPDM Code	FPM Code	PTFE Code	kg
63	50	2	10	1470	199 140 362	199 140 382	199 140 802	5.264
75	65	2 ½	10	2200	199 140 363	199 140 383	199 140 803	4.423
90	80	3	10	3000	199 140 364	199 140 384	199 140 804	4.548
110	100	4	10	6500	199 140 365	199 140 385	199 140 805	5.034
140	125	5	10	11500	199 140 366	199 140 386	199 140 806	5.271
160	150	6	10	16600	199 140 367	199 140 387	199 140 807	6.256
225	200	8	10	39600	199 140 368	199 140 388	199 140 808	9.656
280	250	10	6	55200	199 140 369	199 140 389	199 140 809	13.747
315	300	12	4	80000	199 140 370	199 140 390	199 140 810	16.722
* 355	350	14	6	900000	199 140 371	199 140 391		46.180
* 400	400	16	6	115000	199 140 372	199 140 392		63.800
* 450	450	18	5	155000	199 140 373	199 140 393		78.800
* 500	500	20	4	204000	199 140 374	199 140 394		96.200
* 630	600	24	4	265000	199 140 375	199 140 395		153.000

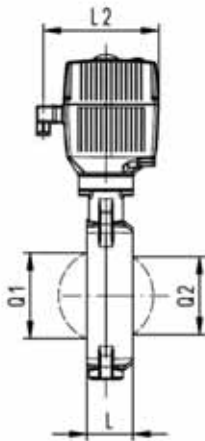

d [mm]	Actuator unit type	D [mm]	D1 min. [mm]	D1 max. [mm]	d2 [mm]	H [mm]	H1 [mm]	H2 [mm]	H3 [mm]	L [mm]	L1 [mm]	L2 [mm]
63	EA-31	19	120.0	125.0	104	400	77	134	188	45	122	180
75	EA-31	19	139.7	145.0	115	413	83	140	188	46	122	180
90	EA-31	19	150.0	160.0	131	428	89	146	188	49	122	180
110	EA-31	19	175.0	190.5	161	460	104	167	188	56	122	180
140	EA-31	23	210.0	215.9	187	487	117	181	188	64	122	180
160	EA-31	24	241.3	241.3	215	508	130	189	188	72	122	180
225	EA-42	23	290.0	295.0	267	575	158	210	208	73	122	180
280	EA-42	25	353.0	362.0	329	677	205	264	208	113	122	180
315	EA-42	25	400.0	432.0	379	721	228	285	208	113	122	180
* 355	VS-300	29	445.0	477.0	535	936	268	410	258	129	209	275
* 400	VT-600	29	510.0	540.0	595	1084	300	435	349	169	228	468
* 450	VT-600	32	565.0	578.0	635	1189	320	520	349	179	228	468
* 500	VT-600	32	620.0	635.0	700	1249	350	550	349	190	228	468
* 630	VT-1000	35	725.0	750.0	813	1379	420	610	349	209	228	468

d [mm]	Q1 [mm]	Q2 [mm]
63	40	
75	54	35
90	67	50
110	88	74
140	113	97
160	139	123
225	178	169
280	210	207
315	256	253
* 355	325	305
* 400	353	350

table continued next page

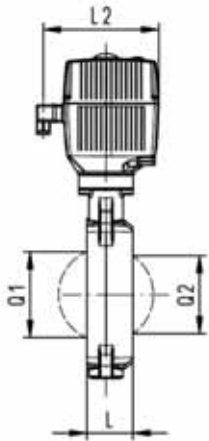
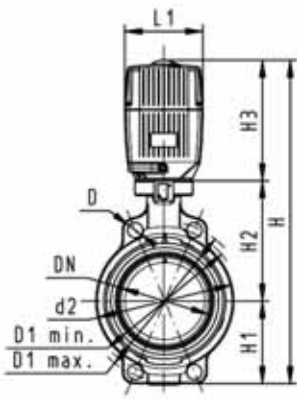

d [mm]	Q1 [mm]	Q2 [mm]
* 450	393	390
* 500	444	440
* 630	530	527

Butterfly valve type 140 PP-H 24V With manual override

Model:

- Material: PP-H
- Connecting dimension: ISO 7005 PN 10, EN 1092 PN 10, DIN 2501 PN 10, ANSI/ASME B 16.5 Class 150, BS 1560: 1989, BS 4504, JIS B 2220
- Overall length according to EN 558, ISO 5752
- Voltage 24 V AC/DC
- Control time 15 s/90°<) EA31
- Control time 25s/90°<) EA42
- Control range 90°<)
- Actuator with integrated emergency manual override standard

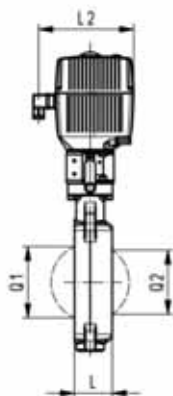
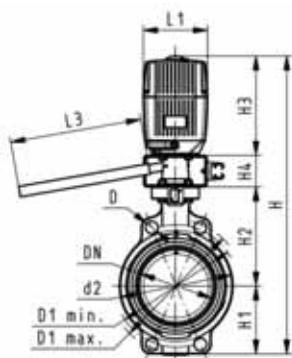

d [mm]	DN [mm]	Inch	PN	kv-value ($\Delta p=1$ bar) [l/min]	EPDM Code	FPM Code	PTFE Code	kg
63	50	2	10	1470	199 140 402	199 140 422	199 140 862	5.603
75	65	2 ½	10	2200	199 140 403	199 140 423	199 140 863	5.694
90	80	3	10	3000	199 140 404	199 140 424	199 140 864	5.822
110	100	4	10	6500	199 140 405	199 140 425	199 140 865	6.327
140	125	5	10	11500	199 140 406	199 140 426	199 140 866	6.771
160	150	6	10	16600	199 140 407	199 140 427	199 140 867	7.556
225	200	8	10	39600	199 140 408	199 140 428	199 140 868	13.271

d [mm]	Actuator unit type	D [mm]	D1 min. [mm]	D1 max. [mm]	d2 [mm]	H [mm]	H1 [mm]	H2 [mm]	H3 [mm]	H4 [mm]	L [mm]	L1 [mm]	L2 [mm]
63	EA-31	19	120.0	125.0	104	460	77	134	188	60	45	122	180
75	EA-31	19	139.7	145.0	115	473	83	140	188	60	46	122	180
90	EA-31	19	150.0	160.0	131	488	89	146	188	60	49	122	180
110	EA-31	19	175.0	190.5	161	520	104	167	188	60	56	122	180
140	EA-31	23	210.0	215.9	187	547	117	181	188	60	64	122	180
160	EA-31	24	241.3	241.3	215	568	130	189	188	60	72	122	180
225	EA-42	23	290.0	295.0	267	635	158	210	208	60	73	122	180

d [mm]	L3 [mm]	Q1 [mm]	Q2 [mm]
63	250	40	
75	250	54	35
90	250	67	50
110	250	88	74
140	250	113	97
160	250	139	123
225	250	178	169



Butterfly valve type 140 PP-H 24V Without manual override

Model:

- Material: PP-H
- Connecting dimension: ISO 7005 PN 10, EN 1092 PN 10, DIN 2501 PN 10, ANSI/ASME B 16.5 Class 150, BS 1560: 1989, BS 4504, JIS B 2220
- Overall length according to EN 558, ISO 5752
- Voltage 24 V AC/DC
- Control time 15 s/90°<) EA31
- Control time 25s/90°<) EA42
- Control range 90°<)
- Actuator with integrated emergency manual override standard
- 12" PVC, 12"-24" PP, available on request

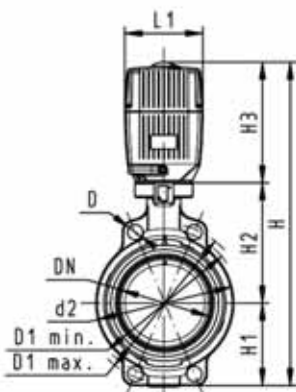

d [mm]	DN [mm]	Inch	PN	kv-value ($\Delta p=1$ bar) [l/min]	EPDM Code	FPM Code	PTFE Code	kg
63	50	2	10	1470	199 140 442	199 140 462	199 140 822	4.314
75	65	2 ½	10	2200	199 140 443	199 140 463	199 140 823	4.194
90	80	3	10	3000	199 140 444	199 140 464	199 140 824	4.529
110	100	4	10	6500	199 140 445	199 140 465	199 140 825	5.017
140	125	5	10	11500	199 140 446	199 140 466	199 140 826	5.271
160	150	6	10	16600	199 140 447	199 140 467	199 140 827	6.056
225	200	8	10	39600	199 140 448	199 140 468	199 140 828	11.771
280	250	10	6	55200	199 140 449	199 140 469	199 140 829	13.747
315	300	12	4	80000	199 140 450	199 140 470	199 140 830	16.722

d [mm]	Actuator unit type	D [mm]	D1 min. [mm]	D1 max. [mm]	d2 [mm]	H [mm]	H1 [mm]	H2 [mm]	H3 [mm]	L [mm]	L1 [mm]	L2 [mm]	Q1 [mm]
63	EA-31	19	120.0	125.0	104	400	77	134	188	45	122	180	40
75	EA-31	19	139.7	145.0	115	413	83	140	188	46	122	180	54
90	EA-31	19	150.0	160.0	131	428	89	146	188	49	122	180	67
110	EA-31	19	175.0	190.5	161	460	104	167	188	56	122	180	88
140	EA-31	23	210.0	215.9	187	487	117	181	188	64	122	180	113
160	EA-31	24	241.3	241.3	215	508	130	189	188	72	122	180	139
225	EA-42	23	290.0	295.0	267	575	158	210	208	73	122	180	178
280	EA-42	25	353.0	362.0	329	677	205	264	208	113	122	180	210
315	EA-42	25	400.0	432.0	379	721	228	285	208	113	122	180	256

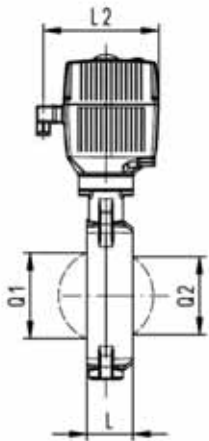

d [mm]	Q2 [mm]
63	
75	35
90	50
110	74
140	97
160	123
225	169
280	207
315	253

PROGEF Standard Lugstyle butterfly valve type 141 100-230V Without manual override

Model:

- Material: PP-H
- Outer body in GGG-40.3 epoxy-coated
- Connecting dimension: ISO 7005 PN10, EN 1092 PN10, DIN 2501 PN10
- Overall length according to EN 558, ISO 5752
- Voltage 100-230 V, 50-60 Hz
- Control time 15 s/90°<) EA31
- Control time 25s/90°<) EA42
- Control range 90°<)
- Actuator with integrated emergency manual override standard

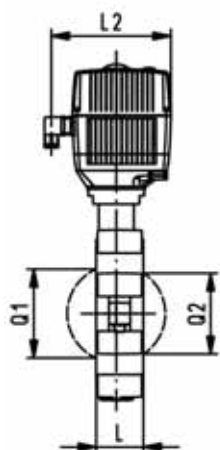
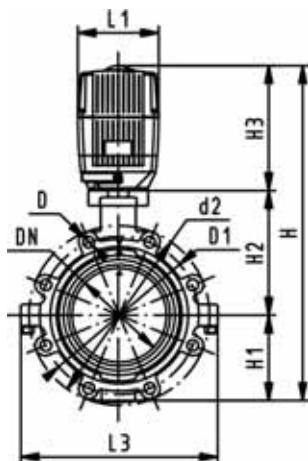

d [mm]	DN [mm]	Inch	PN	kv-value ($\Delta p=1$ bar) [l/min]	EPDM Code	FPM Code	PTFE Code	kg
63	50	2	10	1470	199 141 362	199 141 382	199 141 802	6.193
75	65	2 ½	10	2200	199 141 363	199 141 383	199 141 803	6.535
90	80	3	10	3000	199 141 364	199 141 384	199 141 804	7.540
110	100	4	10	6500	199 141 365	199 141 385	199 141 805	8.925
140	125	5	10	11500	199 141 366	199 141 386	199 141 806	10.755
160	150	6	10	16600	199 141 367	199 141 387	199 141 807	12.539
225	200	8	10	39600	199 141 368	199 141 388	199 141 808	21.747

d [mm]	Actuator unit type	D	D1 [mm]	d2 [mm]	H [mm]	H1 [mm]	H2 [mm]	H3 [mm]	L [mm]	L1 [mm]	L2 [mm]	L3 [mm]	Q1 [mm]
63	EA-31	M16	125	150	399	77	134	188	45	122	180	150	40
75	EA-31	M16	145	170	411	83	140	188	46	122	180	160	54
90	EA-31	M16	160	184	423	89	146	188	49	122	180	205	67
110	EA-31	M16	180	216	459	104	167	188	56	122	180	244	88
140	EA-31	M16	210	246	486	117	181	188	64	122	180	272	113
160	EA-31	M20	240	273	507	130	189	188	72	122	180	297	139
225	EA-42	M20	295	334	576	158	210	208	73	122	180	360	178

d [mm]	Q2 [mm]
63	
75	35
90	50
110	74
140	97
160	123
225	169

PROGEF Standard Lugstyle butterfly valve type 141 100-230V With manual override



Model:

- Material: PP-H
- Outer body in GGG-40.3 epoxy-coated
- Connecting dimension: ISO 7005 PN10, EN 1092 PN10, DIN 2501 PN10
- Overall length according to EN 558, ISO 5752
- Voltage 100-230 V, 50-60 Hz
- Control time 15 s/90°<) EA31
- Control time 25s/90°<) EA42
- Control range 90°<)
- Actuator with integrated emergency manual override standard

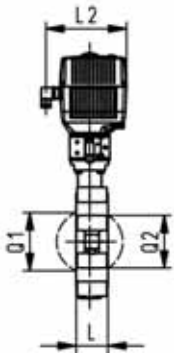
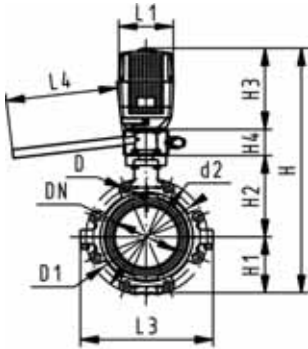

d [mm]	DN [mm]	Inch	PN	kv-value ($\Delta p=1$ bar) [l/min]	EPDM Code	FPM Code	PTFE Code	kg
63	50	2	10	1470	199 141 322	199 141 342	199 141 842	7.693
75	65	2 ½	10	2200	199 141 323	199 141 343	199 141 843	8.035
90	80	3	10	3000	199 141 324	199 141 344	199 141 844	9.040
110	100	4	10	6500	199 141 325	199 141 345	199 141 845	10.425
140	125	5	10	11500	199 141 326	199 141 346	199 141 846	12.255
160	150	6	10	16600	199 141 327	199 141 347	199 141 847	14.039
225	200	8	10	39600	199 141 328	199 141 348	199 141 848	23.247

d [mm]	Actuator unit type	D	D1 [mm]	d2 [mm]	H [mm]	H1 [mm]	H2 [mm]	H3 [mm]	H4 [mm]	L [mm]	L1 [mm]	L2 [mm]	L3 [mm]
63	EA-31	M16	125	150	459	77	134	188	60	45	122	180	150
75	EA-31	M16	145	170	471	83	140	188	60	46	122	180	160
90	EA-31	M16	160	184	483	89	146	188	60	49	122	180	205
110	EA-31	M16	180	216	519	104	167	188	60	56	122	180	244
140	EA-31	M16	210	246	546	117	181	188	60	64	122	180	272
160	EA-31	M20	240	273	567	130	189	188	60	72	122	180	297
225	EA-42	M20	295	334	636	158	210	208	60	73	122	180	360

d [mm]	L4 [mm]	Q1 [mm]	Q2 [mm]
63	200	40	
75	200	54	35
90	200	67	50
110	250	88	74
140	250	113	97
160	250	139	123
225	250	178	169

PROGEF Standard Lugstyle butterfly valve type 141 24V Without manual override

Model:

- Material: PP-H
- Outer body in GGG-40.3 epoxy-coated
- Connecting dimension: ISO 7005 PN10, EN 1092 PN10, DIN 2501 PN10
- Overall length according to EN 558, ISO 5752
- Voltage 24 V AC/DC
- Control time 15 s/90°<) EA31
- Control time 25s/90°<) EA42
- Control range 90°<)
- Actuator with integrated emergency manual override standard

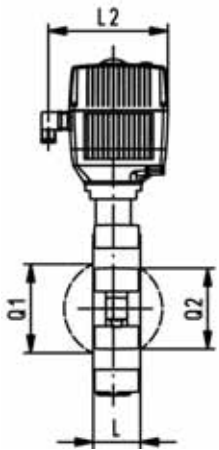
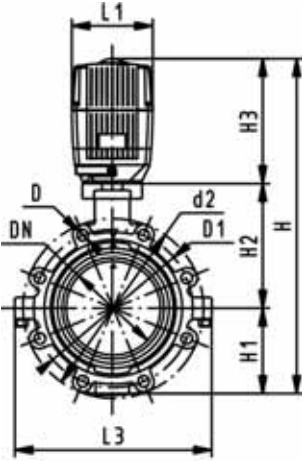

d [mm]	DN [mm]	Inch	PN	kv-value ($\Delta p=1$ bar) [l/min]	EPDM Code	FPM Code	PTFE Code	kg
63	50	2	10	1470	199 141 442	199 141 462	199 141 822	6.193
75	65	2 ½	10	2200	199 141 443	199 141 463	199 141 823	6.535
90	80	3	10	3000	199 141 444	199 141 464	199 141 824	7.540
110	100	4	10	6500	199 141 445	199 141 465	199 141 825	8.925
140	125	5	10	11500	199 141 446	199 141 466	199 141 826	10.755
160	150	6	10	16600	199 141 447	199 141 467	199 141 827	12.539
225	200	8	10	39600	199 141 448	199 141 468	199 141 828	21.747

d [mm]	Actuator unit type	D	D1 [mm]	d2 [mm]	H [mm]	H1 [mm]	H2 [mm]	H3 [mm]	L [mm]	L1 [mm]	L2 [mm]	L3 [mm]	Q1 [mm]
63	EA-31	M16	125	150	399	77	134	188	45	122	180	150	40
75	EA-31	M16	145	170	411	83	140	188	46	122	180	160	54
90	EA-31	M16	160	184	423	89	146	188	49	122	180	205	67
110	EA-31	M16	180	216	459	104	167	188	56	122	180	244	88
140	EA-31	M16	210	246	486	117	181	188	64	122	180	272	113
160	EA-31	M20	240	273	507	130	189	188	72	122	180	297	139
225	EA-42	M20	295	334	576	158	210	208	73	122	180	360	178

d [mm]	Q2 [mm]
63	
75	35
90	50
110	74
140	97
160	123
225	169



PROGEF Standard Lugstyle butterfly valve type 141 24V With manual override

Model:

- Material: PP-H
- Outer body in GGG-40.3 epoxy-coated
- Connecting dimension: ISO 7005 PN10, EN 1092 PN10, DIN 2501 PN10
- Overall length according to EN 558, ISO 5752
- Voltage 24 V AC/DC
- Control time 15 s/90°<) EA31
- Control time 25s/90°<) EA42
- Control range 90°<)
- Actuator with integrated emergency manual override standard

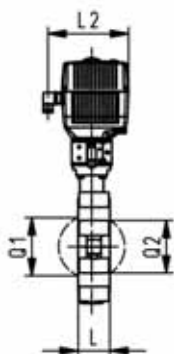
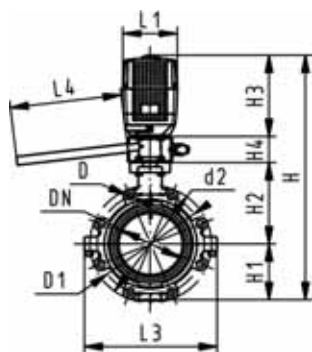

d [mm]	DN [mm]	Inch	PN	kv-value ($\Delta p=1$ bar) [l/min]	EPDM Code	FPM Code	PTFE Code	kg
63	50	2	10	1470	199 141 402	199 141 422	199 141 862	7.693
75	65	2 ½	10	2200	199 141 403	199 141 423	199 141 863	8.035
90	80	3	10	3000	199 141 404	199 141 424	199 141 864	9.040
110	100	4	10	6500	199 141 405	199 141 425	199 141 865	10.425
140	125	5	10	11500	199 141 406	199 141 426	199 141 866	12.255
160	150	6	10	16600	199 141 407	199 141 427	199 141 867	14.039
225	200	8	10	39600	199 141 408	199 141 428	199 141 868	23.247

d [mm]	Actuator unit type	D	D1 [mm]	d2 [mm]	H [mm]	H1 [mm]	H2 [mm]	H3 [mm]	H4 [mm]	L [mm]	L1 [mm]	L2 [mm]	L3 [mm]
63	EA-31	M16	125	150	459	77	134	188	60	45	122	180	150
75	EA-31	M16	145	170	471	83	140	188	60	46	122	180	160
90	EA-31	M16	160	184	483	89	146	188	60	49	122	180	205
110	EA-31	M16	180	216	519	104	167	188	60	56	122	180	244
140	EA-31	M16	210	246	546	117	181	188	60	64	122	180	272
160	EA-31	M20	240	273	567	130	189	188	60	72	122	180	297
225	EA-42	M20	295	334	636	158	210	208	60	73	122	180	360

d [mm]	L4 [mm]	Q1 [mm]	Q2 [mm]
63	200	40	
75	200	54	35
90	200	67	50
110	250	88	74
140	250	113	97
160	250	139	123
225	250	178	169

PROGEF Standard Lugstyle butterfly valve type 142 100-230V Without manual override

Model:

- Material: PP-H
- Outer body in GGG-40.3 epoxy-coated
- Connecting dimension ANSI/ASME B 16.5 Class 150
- Overall length according to EN 558, ISO 5752
- Voltage 100-230 V, 50-60 Hz
- Control time 15 s/90°<) EA31
- Control time 25s/90°<) EA42
- Control range 90°<)
- Actuator with integrated emergency manual override standard

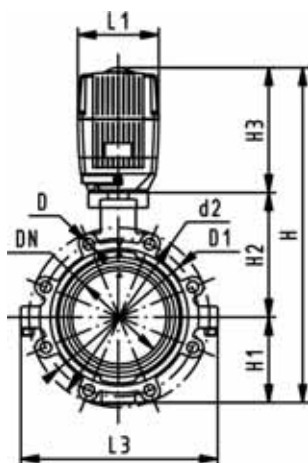

Inch	DN [mm]	d [mm]	PN	kv-value ($\Delta p=1$ bar) [l/min]	EPDM Code	FPM Code	PTFE Code	kg
2	50	63	10	1470	199 142 362	199 142 382	199 142 802	6.193
2 ½	65	75	10	2200	199 142 363	199 142 383	199 142 803	6.535
3	80	90	10	3000	199 142 364	199 142 384	199 142 804	6.911
4	100	110	10	6500	199 142 365	199 142 385	199 142 805	8.925
5	125	140	10	11500	199 142 366	199 142 386	199 142 806	10.755
6	150	160	10	16600	199 142 367	199 142 387	199 142 807	12.539
8	200	225	10	39600	199 142 368	199 142 388	199 142 808	21.747

Inch	Actuator unit type	D	D1 [mm]	d2 [mm]	H [mm]	H1 [mm]	H2 [mm]	H3 [mm]	L [mm]	L1 [mm]	L2 [mm]	L3 [mm]
2	EA-31	UNC 5/8	121	150	399	77	134	188	45	122	180	150
2 ½	EA-31	UNC 5/8	140	170	411	83	140	188	46	122	180	160
3	EA-31	UNC 5/8	153	177	423	89	146	188	49	122	180	175
4	EA-31	UNC 5/8	191	216	459	104	167	188	56	122	180	244
5	EA-31	UNC 3/4	216	246	486	117	181	188	64	122	180	272
6	EA-31	UNC 3/4	242	273	507	130	189	188	72	122	180	297
8	EA-42	UNC 3/4	299	334	576	158	210	208	73	122	180	360

Inch	Q1 [mm]	Q2 [mm]
2	40	
2 ½	54	35
3	67	50
4	88	74
5	113	97
6	139	123
8	178	169

PROGEF Standard Lugstyle butterfly valve type 142 100-230V With manual override



Model:

- Material: PP-H
- Outer body in GGG-40.3 epoxy-coated
- Connecting dimension ANSI/ASME B 16.5 Class 150
- Overall length according to EN 558, ISO 5752
- Voltage 100-230 V, 50-60 Hz
- Control time 15 s/90°<) EA31
- Control time 25s/90°<) EA42
- Control range 90°<)
- Actuator with integrated emergency manual override standard

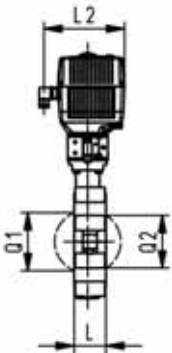
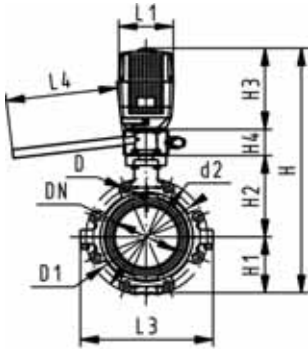

Inch	DN [mm]	d [mm]	PN	kv-value ($\Delta p=1$ bar) [l/min]	EPDM Code	FPM Code	PTFE Code	kg
2	50	63	10	1470	199 142 322	199 142 342	199 142 842	6.193
2 ½	65	75	10	2200	199 142 323	199 142 343	199 142 843	6.535
3	80	90	10	3000	199 142 324	199 142 344	199 142 844	6.911
4	100	110	10	6500	199 142 325	199 142 345	199 142 845	8.925
5	125	140	10	11500	199 142 326	199 142 346	199 142 846	10.755
6	150	160	10	16600	199 142 327	199 142 347	199 142 847	12.539
8	200	225	10	39600	199 142 328	199 142 348	199 142 848	21.747

Inch	Actuator unit type	D	D1 [mm]	d2 [mm]	H [mm]	H1 [mm]	H2 [mm]	H3 [mm]	H4 [mm]	L [mm]	L1 [mm]	L2 [mm]	L3 [mm]
2	EA-31	UNC 5/8	121	150	459	77	134	188	60	45	122	180	150
2 ½	EA-31	UNC 5/8	140	170	471	83	140	188	60	46	122	180	160
3	EA-31	UNC 5/8	153	177	483	89	146	188	60	49	122	180	175
4	EA-31	UNC 5/8	191	216	519	104	167	188	60	56	122	180	244
5	EA-31	UNC 3/4	216	246	546	117	181	188	60	64	122	180	272
6	EA-31	UNC 3/4	242	273	567	130	189	188	60	72	122	180	297
8	EA-42	UNC 3/4	299	334	636	158	210	208	60	73	122	180	360

Inch	L4 [mm]	Q1 [mm]	Q2 [mm]
2	200	40	
2 ½	200	54	35
3	200	67	50
4	250	88	74
5	250	113	97
6	250	139	123
8	250	178	169

PROGEF Standard Lugstyle butterfly valve type 142 24V Without manual override

Model:

- Material: PP-H
- Outer body in GGG-40.3 epoxy-coated
- Connecting dimension ANSI/ASME B 16.5 Class 150
- Overall length according to EN 558, ISO 5752
- Voltage 24 V AC/DC
- Control time 15 s/90°<) EA31
- Control time 25s/90°<) EA42
- Control range 90°<)
- Actuator with integrated emergency manual override standard

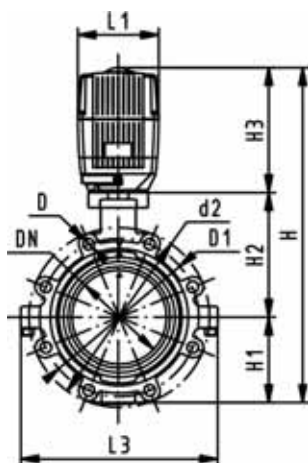

Inch	DN [mm]	d [mm]	PN	kv-value ($\Delta p=1$ bar) [l/min]	EPDM Code	FPM Code	PTFE Code	kg
2	50	63	10	1470	199 142 442	199 142 462	199 142 822	6.193
2 ½	65	75	10	2200	199 142 443	199 142 463	199 142 823	6.535
3	80	90	10	3000	199 142 444	199 142 464	199 142 824	6.911
4	100	110	10	6500	199 142 445	199 142 465	199 142 825	8.925
5	125	140	10	11500	199 142 446	199 142 466	199 142 826	10.755
6	150	160	10	16600	199 142 447	199 142 467	199 142 827	12.539
8	200	225	10	39600	199 142 448	199 142 468	199 142 828	21.747

Inch	Actuator unit type	D	D1 [mm]	d2 [mm]	H [mm]	H1 [mm]	H2 [mm]	H3 [mm]	L [mm]	L1 [mm]	L2 [mm]	L3 [mm]
2	EA-31	UNC 5/8	121	150	399	77	134	188	45	122	180	150
2 ½	EA-31	UNC 5/8	140	170	411	83	140	188	46	122	180	160
3	EA-31	UNC 5/8	153	177	423	89	146	188	49	122	180	175
4	EA-31	UNC 5/8	191	216	459	104	167	188	56	122	180	244
5	EA-31	UNC 3/4	216	246	486	117	181	188	64	122	180	272
6	EA-31	UNC 3/4	242	273	507	130	189	188	72	122	180	297
8	EA-42	UNC 3/4	299	334	576	158	210	208	73	122	180	360

Inch	Q1 [mm]	Q2 [mm]
2	40	
2 ½	54	35
3	67	50
4	88	74
5	113	97
6	139	123
8	178	169



PROGEF Standard Lugstyle butterfly valve type 142 24V With manual override

Model:

- Material: PP-H
- Outer body in GGG-40.3 epoxy-coated
- Connecting dimension ANSI/ASME B 16.5 Class 150
- Overall length according to EN 558, ISO 5752
- Voltage 24 V AC/DC
- Control time 15 s/90°<) EA31
- Control time 25s/90°<) EA42
- Control range 90°<)
- Actuator with integrated emergency manual override standard

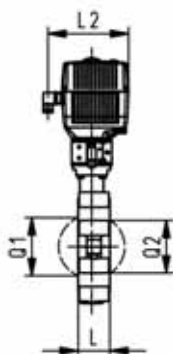
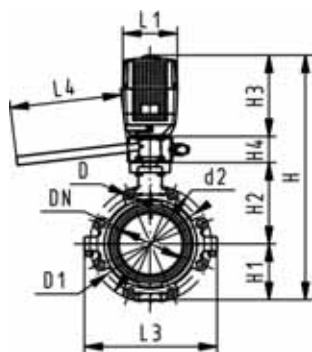

Inch	DN [mm]	d [mm]	PN	kv-value ($\Delta p=1$ bar) [l/min]	EPDM Code	FPM Code	PTFE Code	kg
2	50	63	10	1470	199 142 402	199 142 422	199 142 862	6.193
2 ½	65	75	10	2200	199 142 403	199 142 423	199 142 863	6.535
3	80	90	10	3000	199 142 404	199 142 424	199 142 864	6.911
4	100	110	10	6500	199 142 405	199 142 425	199 142 865	8.925
5	125	140	10	11500	199 142 406	199 142 426	199 142 866	10.755
6	150	160	10	16600	199 142 407	199 142 427	199 142 867	12.539
8	200	225	10	39600	199 142 408	199 142 428	199 142 868	21.747

Inch	Actuator unit type	D	D1 [mm]	d2 [mm]	H [mm]	H1 [mm]	H2 [mm]	H3 [mm]	H4 [mm]	L [mm]	L1 [mm]	L2 [mm]	L3 [mm]
2	EA-31	UNC 5/8	121	150	459	77	134	188	60	45	122	180	150
2 ½	EA-31	UNC 5/8	140	170	471	83	140	188	60	46	122	180	160
3	EA-31	UNC 5/8	153	177	483	89	146	188	60	49	122	180	175
4	EA-31	UNC 5/8	191	216	519	104	167	188	60	56	122	180	244
5	EA-31	UNC 3/4	216	246	546	117	181	188	60	64	122	180	272
6	EA-31	UNC 3/4	242	273	567	130	189	188	60	72	122	180	297
8	EA-42	UNC 3/4	299	334	636	158	210	208	60	73	122	180	360

Inch	L4 [mm]	Q1 [mm]	Q2 [mm]
2	200	40	
2 ½	200	54	35
3	200	67	50
4	250	88	74
5	250	113	97
6	250	139	123
8	250	178	169

Butterfly Valves Pneumatic

Butterfly valve type 240 PP-H FC (Fail safe to close) Without manual override

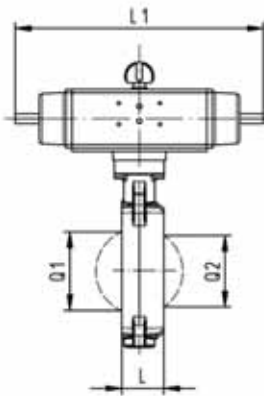
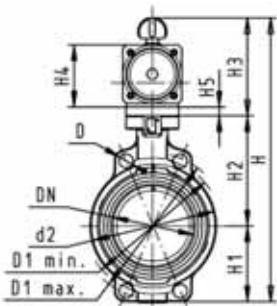

Model:

- Material: PP-H, DN350-DN600 material PP-R
- For DN350-DN600 pneumatic actuator supplied by Revac
- Connecting dimension: ISO 7005 PN 10, EN 1092 PN 10, DIN 2501 PN 10, ANSI/ASME B 16.5 Class 150, BS 1560: 1989, BS 4504, JIS B 2220
- Up to DN 300: Overall length according to EN558 (DN 50-200: line 25, DN250, 300 line 16), ISO 5752
- Control range 90°<

d [mm]	DN [mm]	Inch	PN	kv-value ($\Delta p=1$ bar) [l/min]	EPDM Code	FPM Code	PTFE Code	kg
63	50	2	10	1470	199 240 282	199 240 302	199 240 702	2.909
75	65	2 ½	10	2200	199 240 283	199 240 303	199 240 703	2.999
90	80	3	10	3000	199 240 284	199 240 304	199 240 704	3.787
110	100	4	10	6500	199 240 285	199 240 305	199 240 705	4.996
140	125	5	10	11500	199 240 286	199 240 306	199 240 706	6.790
160	150	6	10	16600	199 240 287	199 240 307	199 240 707	9.533
225	200	8	10	39600	199 240 288	199 240 308	199 240 708	13.430
280	250	10	8	55200	199 240 289	199 240 309	199 240 709	26.888
315	300	12	8	80000	199 240 290	199 240 310	199 240 710	33.459

d [mm]	Actuator unit type	D [mm]	D1 min. [mm]	D1 max. [mm]	d2 [mm]	H [mm]	H1 [mm]	H2 [mm]	H3 [mm]	H4 [mm]	H5 [mm]	L [mm]	L1 [mm]
63	PA-30 FC	19	120.0	125.0	104	327	77	134	117	70	15	45	276
75	PA-30 FC	19	139.7	145.0	115	340	83	140	117	70	15	46	276
90	PA-35 FC	19	150.0	160.0	131	361	89	146	126	78	15	49	326
110	PA-40 FC	19	175.0	190.5	161	400	104	167	129	86		56	370
140	PA-45 FC	23	210.0	215.9	187	436	117	181	139	96		64	411
160	PA-50 FC	24	241.3	241.3	215	468	130	189	149	106		72	423
225	PA-55 FC	23	290.0	295.0	267	529	158	210	161	118		73	452
280	PA-65 FC	25	353.0	362.0	329	808	205	264	191	148		113	648
315	PA-70 FC	25	400.0	432.0	379	866	228	285	196	157		113	663

d [mm]	Q1 [mm]	Q2 [mm]
63	40	
75	54	35
90	67	50
110	88	74
140	113	97
160	139	123
225	178	169
280	210	207
315	256	253



Butterfly valve type 240 PP-H FO (Fail safe to open) Without manual override

Model:

- Material: PP-H
- Connecting dimension: ISO 7005 PN 10, EN 1092 PN 10, DIN 2501 PN 10, ANSI/ASME B 16.5 Class 150, BS 1560: 1989, BS 4504, JIS B 2220
- Overall length according to EN 558, ISO 5752
- Control range 90°<

d [mm]	DN [mm]	Inch	PN	kv-value ($\Delta p=1$ bar) [l/min]	EPDM Code	FPM Code	PTFE Code	kg
63	50	2	10	1470	199 240 322	199 240 342	199 240 722	3.143
75	65	2 ½	10	2200	199 240 323	199 240 343	199 240 723	3.234
90	80	3	10	3000	199 240 324	199 240 344	199 240 724	3.362
110	100	4	10	6500	199 240 325	199 240 345	199 240 725	4.988
140	125	5	10	11500	199 240 326	199 240 346	199 240 726	6.511
160	150	6	10	16600	199 240 327	199 240 347	199 240 727	9.617
225	200	8	10	39600	199 240 328	199 240 348	199 240 728	13.271
280	250	10	8	55200	199 240 329	199 240 349	199 240 729	30.484
315	300	12	8	80000	199 240 330	199 240 350	199 240 730	33.459

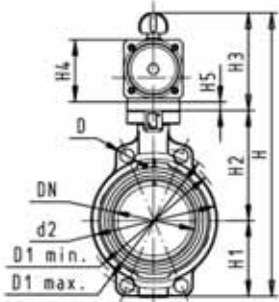

d [mm]	Actuator unit type	D [mm]	D1 min. [mm]	D1 max. [mm]	d2 [mm]	H [mm]	H1 [mm]	H2 [mm]	H3 [mm]	H4 [mm]	H5 [mm]	L [mm]	L1 [mm]
63	PA-30 FO	19	120.0	125.0	104	327	77	134	117	70	15	45	276
75	PA-30 FO	19	139.7	145.0	115	340	83	140	117	70	15	46	276
90	PA-35 FO	19	150.0	160.0	131	361	89	146	126	78	15	49	326
110	PA-40 FO	19	175.0	190.5	161	400	104	167	129	86		56	370
140	PA-45 FO	23	210.0	215.9	187	436	117	181	139	96		64	411
160	PA-50 FO	24	241.3	241.3	215	468	130	189	149	106		72	423
225	PA-55 FO	23	290.0	295.0	267	529	158	210	161	118		73	452
280	PA-70 FO	25	353.0	362.0	329	808	205	264	191	148		113	648
315	PA-70 FO	25	400.0	432.0	379	866	228	285	196	157		113	663

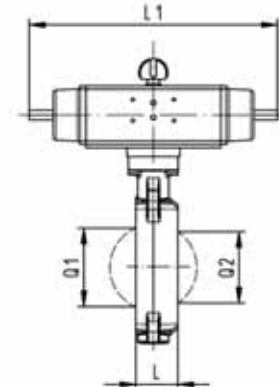

d [mm]	L2 [mm]	Q1 [mm]	Q2 [mm]
63	65	40	
75	65	54	35
90	72	67	50
110	80	88	74
140	90	113	97
160	100	139	123
225	112	178	169
280	137	210	207
315	145	256	253



Butterfly valve type 240 PP-H DA (Double acting) Without manual override

Model:

- For DN350-DN600 pneumatic actuator supplied by Revac
- Material: PP-H, DN350-DN600 material PP-R
- Connecting dimension: ISO 7005 PN 10, EN 1092 PN 10, DIN 2501 PN 10, ANSI/ASME B 16.5 Class 150, BS 1560: 1989, BS 4504, JIS B 2220
- Up to DN 300: Overall length according to EN558 (DN 50-200: line 25, DN250, 300 line 16), ISO 5752
- Control range 90°<

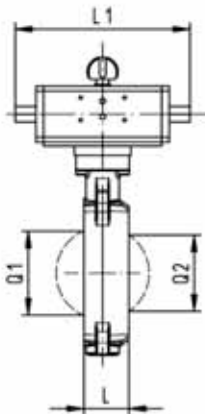
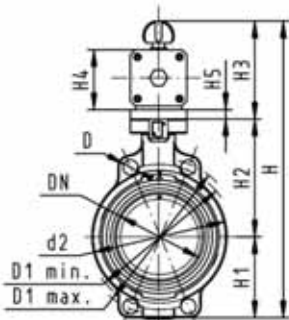

d [mm]	DN [mm]	Inch	PN	kv-value ($\Delta p=1$ bar) [l/min]	EPDM Code	FPM Code	PTFE Code	kg
63	50	2	10	1470	199 240 362	199 240 382	199 240 742	2.227
75	65	2 ½	10	2200	199 240 363	199 240 383	199 240 743	2.084
90	80	3	10	3000	199 240 364	199 240 384	199 240 744	2.728
110	100	4	10	6500	199 240 365	199 240 385	199 240 745	3.542
140	125	5	10	11500	199 240 366	199 240 386	199 240 746	3.967
160	150	6	10	16600	199 240 367	199 240 387	199 240 747	6.096
225	200	8	10	39600	199 240 368	199 240 388	199 240 748	7.271
280	250	10	8	55200	199 240 369	199 240 389	199 240 749	18.188
315	300	12	8	80000	199 240 370	199 240 390	199 240 750	24.263
* 355	350	14	6	90000	199 240 371	199 240 391		40.600
* 400	400	16	6	115000	199 240 372	199 240 392		62.100
* 450	450	18	5	155000	199 240 373	199 240 393		77.100
* 500	500	20	4	204000	199 240 374	199 240 394		92.100
* 630	600	24	4	265000	199 240 375	199 240 395		127.100

d [mm]	Actuator unit type	D [mm]	D1 min. [mm]	D1 max. [mm]	d2 [mm]	H [mm]	H1 [mm]	H2 [mm]	H3 [mm]	H4 [mm]	H5 [mm]	L [mm]	L1 [mm]
63	PA-35 DA	19	120.0	125.0	104	317	77	134	107	60	15	45	177
75	PA-35 DA	19	139.7	145.0	115	330	83	140	107	60	15	46	177
90	PA-40 DA	19	150.0	160.0	131	348	89	146	113	66	15	49	190
110	PA-45 DA	19	175.0	190.5	161	372	104	167	102	71		56	235
140	PA-45 DA	23	210.0	215.9	187	408	117	181	111	78		64	235
160	PA-55 DA	24	241.3	241.3	215	448	130	189	129	86		72	279
225	PA-55 DA	23	290.0	295.0	267	507	158	210	139	96		73	279
280	PA-65 DA	25	353.0	362.0	329	748	205	264	161	118		113	350
315	PA-70 DA	25	400.0	432.0	379	816	228	285	173	130		113	381
* 355	AP 5	29	445.0	477.0	535	863	268	410	185	155	27	129	360
* 400	AP 5.5	29	510.0	540.0	595	941	300	435	206	176	27	169	380
* 450	AP 5.5	32	565.0	578.0	635	1046	320	520	206	176	36	179	380
* 500	AP 6	32	620.0	635.0	700	1130	350	550	230	200	36	190	462
* 630	AP8	35	725.0	750.0	813	1330	420	610	300	250	36	209	530

d [mm]	Q1 [mm]	Q2 [mm]
63	40	
75	54	35
90	67	50
110	88	74
140	113	97
160	139	123
225	178	169
280	210	207
315	256	253
* 355	325	305
* 400	353	350
* 450	393	390
* 500	444	440
* 630	530	527



PROGEF Standard Lugstyle butterfly valve type 241 FC (Fail safe to close) Without manual override

Model:

- Material: PP-H
- Outer body in GGG-40.3 epoxy-coated
- Connecting dimension: ISO 7005 PN10, EN 1092 PN10, DIN 2501 PN10
- Overall length according to EN 558, ISO 5752
- Control range 90°<

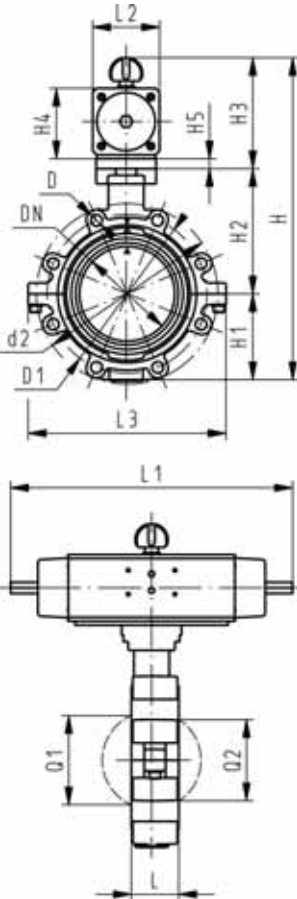

d [mm]	DN [mm]	Inch	PN	kv-value ($\Delta p=1$ bar) [l/min]	EPDM Code	FPM Code	PTFE Code	kg
63	50	2	10	1470	199 241 282	199 241 302	199 241 702	5.233
75	65	2 1/2	10	2200	199 241 283	199 241 303	199 241 703	5.575
90	80	3	10	3000	199 241 284	199 241 304	199 241 704	6.580
110	100	4	10	6500	199 241 285	199 241 305	199 241 705	9.487
140	125	5	10	11500	199 241 286	199 241 306	199 241 706	11.995
160	150	6	10	16600	199 241 287	199 241 307	199 241 707	16.100
225	200	8	10	39600	199 241 288	199 241 308	199 241 708	23.247

d [mm]	Actuator unit type	D	D1 [mm]	d2 [mm]	H [mm]	H1 [mm]	H2 [mm]	H3 [mm]	H4 [mm]	H5 [mm]	L [mm]	L1 [mm]	L2 [mm]
63	PA-30 FC	M16	125	150	328	77	134	117	70	15	45	276	65
75	PA-30 FC	M16	145	170	340	83	140	117	70	15	46	276	65
90	PA-35 FC	M16	160	184	361	89	146	126	78	15	49	326	72
110	PA-40 FC	M16	180	216	400	104	167	129	86		56	370	80
140	PA-45 FC	M16	210	246	437	117	181	139	96		64	411	90
160	PA-50 FC	M20	240	273	468	130	189	149	106		72	423	100
225	PA-55 FC	M20	295	334	529	158	210	161	118		73	452	112

d [mm]	L3 [mm]	Q1 [mm]	Q2 [mm]
63	150	40	
75	160	54	35
90	205	67	50
110	244	88	74
140	272	113	97
160	297	139	123
225	360	178	169



PROGEF Standard Lugstyle butterfly valve type 241 FO (Fail safe to open) Without manual override

Model:

- Material: PP-H
- Outer body in GGG-40.3 epoxy-coated
- Connecting dimension: ISO 7005 PN10, EN 1092 PN10, DIN 2501 PN10
- Overall length according to EN 558, ISO 5752
- Control range 90°<

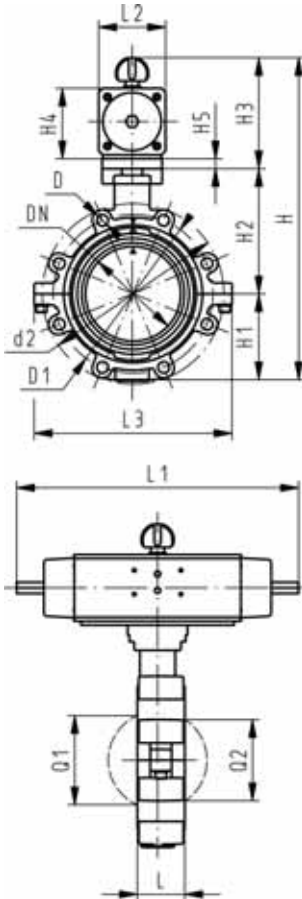

d [mm]	DN [mm]	Inch	PN	kv-value ($\Delta p=1$ bar) [l/min]	EPDM Code	FPM Code	PTFE Code	kg
63	50	2	10	1470	199 241 322	199 241 342	199 241 722	5.123
75	65	2 ½	10	2200	199 241 323	199 241 343	199 241 723	6.396
90	80	3	10	3000	199 241 324	199 241 344	199 241 724	6.580
110	100	4	10	6500	199 241 325	199 241 345	199 241 725	9.163
140	125	5	10	11500	199 241 326	199 241 346	199 241 726	12.951
160	150	6	10	16600	199 241 327	199 241 347	199 241 727	16.100
225	200	8	10	39600	199 241 328	199 241 348	199 241 728	23.247

d [mm]	Actuator unit type	D	D1 [mm]	d2 [mm]	H [mm]	H1 [mm]	H2 [mm]	H3 [mm]	H4 [mm]	H5 [mm]	L [mm]	L1 [mm]	L2 [mm]
63	PA-30 FO	M16	125	150	328	77	134	117	70	15	45	276	65
75	PA-30 FO	M16	145	170	340	83	140	117	70	15	46	276	65
90	PA-35 FO	M16	160	184	361	89	146	126	78	15	49	326	72
110	PA-40 FO	M16	180	216	400	104	167	129	86		56	370	80
140	PA-45 FO	M16	210	246	437	117	181	139	96		64	411	90
160	PA-50 FO	M20	240	273	468	130	189	149	106		72	423	100
225	PA-55 FO	M20	295	334	529	158	210	161	118		73	452	112

d [mm]	L3 [mm]	Q1 [mm]	Q2 [mm]
63	150	40	
75	160	54	35
90	205	67	50
110	244	88	74
140	272	113	97
160	297	139	123
225	360	178	169



PROGEF Standard Lugstyle butterfly valve type 241 DA (Double acting) Without manual override

Model:

- Material: PP-H
- Outer body in GGG-40.3 epoxy-coated
- Connecting dimension: ISO 7005 PN10, EN 1092 PN10, DIN 2501 PN10
- Overall length according to EN 558, ISO 5752
- Control range 90°<

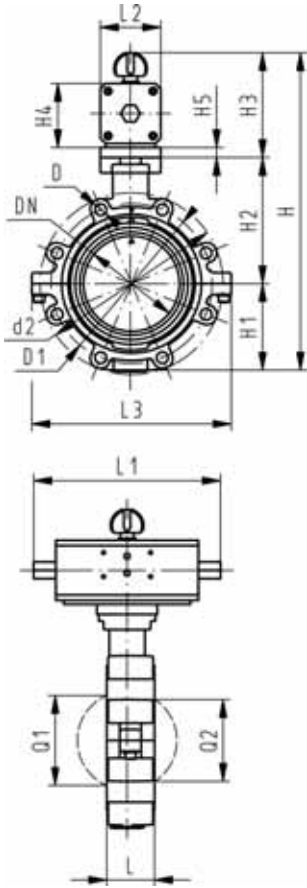

d [mm]	DN [mm]	Inch	PN	kv-value ($\Delta p=1$ bar) [l/min]	EPDM Code	FPM Code	PTFE Code	kg
63	50	2	10	1470	199 241 362	199 241 382	199 241 742	4.083
75	65	2 1/2	10	2200	199 241 363	199 241 383	199 241 743	4.425
90	80	3	10	3000	199 241 364	199 241 384	199 241 744	5.911
110	100	4	10	6500	199 241 365	199 241 385	199 241 745	7.415
140	125	5	10	11500	199 241 366	199 241 386	199 241 746	9.245
160	150	6	10	16600	199 241 367	199 241 387	199 241 747	12.579
225	200	8	10	39600	199 241 368	199 241 388	199 241 748	17.247

d [mm]	Actuator unit type	D	D1 [mm]	d2 [mm]	H [mm]	H1 [mm]	H2 [mm]	H3 [mm]	H4 [mm]	H5 [mm]	L [mm]	L1 [mm]	L2 [mm]
63	PA-35 DA	M16	125	150	318	77	134	107	60	15	45	177	55
75	PA-35 DA	M16	145	170	330	83	140	107	60	15	46	177	55
90	PA-40 DA	M16	160	184	348	89	146	113	66	15	49	190	60
110	PA-45 DA	M16	180	216	373	104	167	102	71		56	235	65
140	PA-45 DA	M16	210	246	409	117	181	111	78		64	235	72
160	PA-55 DA	M20	240	273	448	130	189	129	86		72	279	80
225	PA-55 DA	M20	295	334	507	158	210	139	96		73	279	90

d [mm]	L3 [mm]	Q1 [mm]	Q2 [mm]
63	150	40	
75	160	54	35
90	205	67	50
110	244	88	74
140	272	113	97
160	297	139	123
225	360	178	169



PROGEF Standard Lugstyle butterfly valve type 242 FC (Fail safe to close) Without manual override

Model:

- Material: PP-H
- Outer body in GGG-40.3 epoxy-coated
- Connecting dimension ANSI/ASME B 16.5 Class 150
- Overall length according to EN 558, ISO 5752
- Control range 90°<

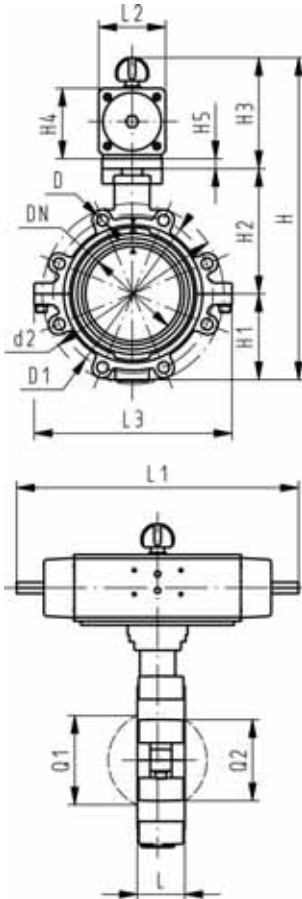

Inch	DN [mm]	d [mm]	PN	kv-value ($\Delta p=1$ bar) [l/min]	EPDM Code	FPM Code	PTFE Code	kg
2	50	63	10	1470	199 242 282	199 242 302	199 242 702	5.233
2 ½	65	75	10	2200	199 242 283	199 242 303	199 242 703	5.575
3	80	90	10	3000	199 242 284	199 242 304	199 242 704	5.951
4	100	110	10	6500	199 242 285	199 242 305	199 242 705	9.163
5	125	140	10	11500	199 242 286	199 242 306	199 242 706	11.995
6	150	160	10	16600	199 242 287	199 242 307	199 242 707	16.100
8	200	225	10	39600	199 242 288	199 242 308	199 242 708	23.247

Inch	Actuator unit type	D	D1 [mm]	d2 [mm]	H [mm]	H1 [mm]	H2 [mm]	H3 [mm]	H4 [mm]	H5 [mm]	L [mm]	L1 [mm]	L2 [mm]
2	PA-30 FC	UNC 5/8	121	150	328	77	134	117	70	15	45	276	65
2 ½	PA-30 FC	UNC 5/8	140	170	340	83	140	117	70	15	46	276	65
3	PA-35 FC	UNC 5/8	153	177	361	89	146	126	78	15	49	326	72
4	PA-40 FC	UNC 5/8	191	216	400	104	167	129	86	15	56	370	80
5	PA-45 FC	UNC 3/4	216	246	437	117	181	139	96	15	64	411	90
6	PA-50 FC	UNC 3/4	242	273	468	130	189	149	106	15	72	423	100
8	PA-55 FC	UNC 3/4	299	334	529	158	210	161	118	15	73	452	112

Inch	L3 [mm]	Q1 [mm]	Q2 [mm]
2	150	40	
2 ½	160	54	35
3	175	67	50
4	244	88	74
5	272	113	97
6	297	139	123
8	360	178	169



PROGEF Standard Lugstyle butterfly valve type 242 FO (Fail safe to open) Without manual override

Model:

- Material: PP-H
- Outer body in GGG-40.3 epoxy-coated
- Connecting dimension ANSI/ASME B 16.5 Class 150
- Overall length according to EN 558, ISO 5752
- Control range 90°<

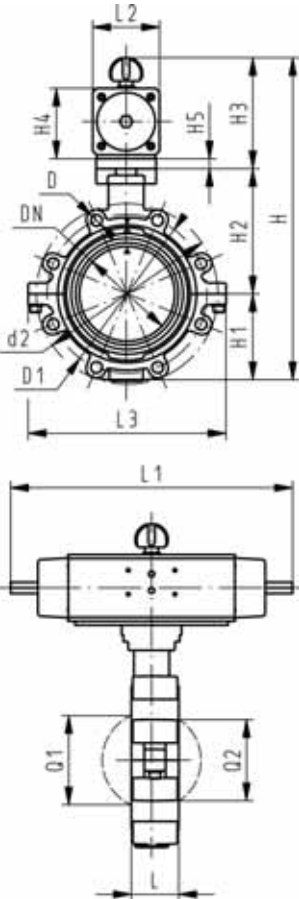

Inch	DN [mm]	d [mm]	PN	kv-value ($\Delta p=1$ bar) [l/min]	EPDM Code	FPM Code	PTFE Code	kg
2	50	63	10	1470	199 242 322	199 242 342	199 242 722	5.233
2 ½	65	75	10	2200	199 242 323	199 242 343	199 242 723	5.575
3	80	90	10	3000	199 242 324	199 242 344	199 242 724	5.951
4	100	110	10	6500	199 242 325	199 242 345	199 242 725	9.163
5	125	140	10	11500	199 242 326	199 242 346	199 242 726	11.995
6	150	160	10	16600	199 242 327	199 242 347	199 242 727	16.100
8	200	225	10	39600	199 242 328	199 242 348	199 242 728	23.247

Inch	Actuator unit type	D	D1 [mm]	d2 [mm]	H [mm]	H1 [mm]	H2 [mm]	H3 [mm]	H4 [mm]	H5 [mm]	L [mm]	L1 [mm]	L2 [mm]
2	PA-30 FO	UNC 5/8	121	150	328	77	134	117	70	15	45	276	65
2 ½	PA-30 FO	UNC 5/8	140	170	340	83	140	117	70	15	46	276	65
3	PA-35 FO	UNC 5/8	153	177	361	89	146	126	78	15	49	326	72
4	PA-40 FO	UNC 5/8	191	216	400	104	167	129	86		56	370	80
5	PA-45 FO	UNC 3/4	216	246	437	117	181	139	96		64	411	90
6	PA-50 FO	UNC 3/4	242	273	468	130	189	149	106		72	423	100
8	PA-55 FO	UNC 3/4	299	334	529	158	210	161	118		73	452	112

Inch	L3 [mm]	Q1 [mm]	Q2 [mm]
2	150	40	
2 ½	160	54	35
3	175	67	50
4	244	88	74
5	272	113	97
6	297	139	123
8	360	178	169



PROGEF Standard Lugstyle butterfly valve type 242 DA (Double acting) Without manual override

Model:

- Material: PP-H
- Outer body in GGG-40.3 epoxy-coated
- Connecting dimension ANSI/ASME B 16.5 Class 150
- Overall length according to EN 558, ISO 5752
- Control range 90°<

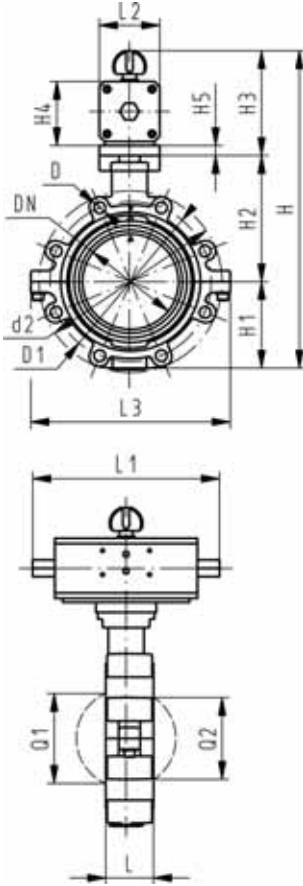

Inch	DN [mm]	d [mm]	PN	kv-value ($\Delta p=1$ bar) [l/min]	EPDM Code	FPM Code	PTFE Code	kg
2	50	63	10	1470	199 242 362	199 242 382	199 242 742	4.083
2 ½	65	75	10	2200	199 242 363	199 242 383	199 242 743	4.425
3	80	90	10	3000	199 242 364	199 242 384	199 242 744	5.282
4	100	110	10	6500	199 242 365	199 242 385	199 242 745	7.415
5	125	140	10	11500	199 242 366	199 242 386	199 242 746	9.245
6	150	160	10	16600	199 242 367	199 242 387	199 242 747	12.579
8	200	225	10	39600	199 242 368	199 242 388	199 242 748	17.247

Inch	Actuator unit type	D	D1 [mm]	d2 [mm]	H [mm]	H1 [mm]	H2 [mm]	H3 [mm]	H4 [mm]	H5 [mm]	L [mm]	L1 [mm]	L2 [mm]
2	PA-35 DA	UNC 5/8	121	150	318	77	134	107	60	15	45	177	55
2 ½	PA-35 DA	UNC 5/8	140	170	330	83	140	107	60	15	46	177	55
3	PA-40 DA	UNC 5/8	153	177	348	89	146	113	66	15	49	190	60
4	PA-45 DA	UNC 5/8	191	216	373	104	167	102	71		56	235	65
5	PA-45 DA	UNC 3/4	216	246	409	117	181	111	78		64	235	72
6	PA-55 DA	UNC 3/4	242	273	448	130	189	129	86		72	279	80
8	PA-55 DA	UNC 3/4	299	334	507	158	210	139	96		73	279	90

Inch	L3 [mm]	Q1 [mm]	Q2 [mm]
2	150	40	
2 ½	160	54	35
3	175	67	50
4	244	88	74
5	272	113	97
6	297	139	123
8	360	178	169

Variable area flow meters

Variable area flow meter type 335

Float in PVDF without magnet

With solvent cement sockets PVC-U metric

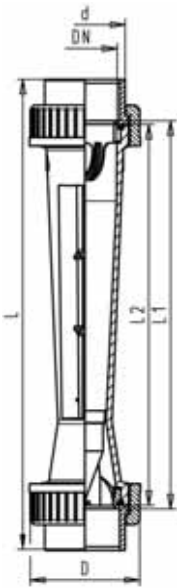

Scale range [l/h]	d [mm]	DN [mm]	Taper tube in PVC-U transp. O- rings in EPDM Code	Taper tube in Polyamid O-rings in EPDM Code	Taper tube in Polysulfone O- rings in EPDM Code	kg
50 - 500	32	25	198 335 000	198 335 020	198 335 040	0.464
100 - 1000	32	25	198 335 001	198 335 021	198 335 041	0.528
150 - 1500	40	32	198 335 002	198 335 022	198 335 042	0.698
250 - 2500	40	32	198 335 003	198 335 023	198 335 043	0.561
200 - 2000	50	40	198 335 004	198 335 024	198 335 044	1.057
300 - 3000	50	40	198 335 005	198 335 025	198 335 045	1.038
600 - 6000	50	40	198 335 006	198 335 026	198 335 046	0.991
600 - 6000	63	50	198 335 007	198 335 027	198 335 047	1.455
1000 - 10000	63	50	198 335 008	198 335 028	198 335 048	1.252
1500 - 15000	63	50	198 335 009	198 335 029	198 335 049	1.429
2000 - 20000	75	65	198 335 010	198 335 030	198 335 050	2.639
3000 - 30000	75	65	198 335 011	198 335 031	198 335 051	2.572
8000 - 60000	75	65	198 335 012	198 335 032	198 335 052	2.432

Scale range [l/h]	D [mm]	L [mm]	L1 [mm]	L2 [mm]	G [inch]
50 - 500	58	385	341	335	1 ½
100 - 1000	58	385	341	335	1 ½
150 - 1500	72	393	341	335	2
250 - 2500	72	393	341	335	2
200 - 2000	83	403	341	335	2 ¼
300 - 3000	83	403	341	335	2 ¼
600 - 6000	83	403	341	335	2 ¼
600 - 6000	101	417	341	335	2 ¾
1000 - 10000	101	417	341	335	2 ¾
1500 - 15000	101	417	341	335	2 ¾
2000 - 20000	135	429	341	335	3 ½
3000 - 30000	135	429	341	335	3 ½
8000 - 60000	135	429	341	335	3 ½

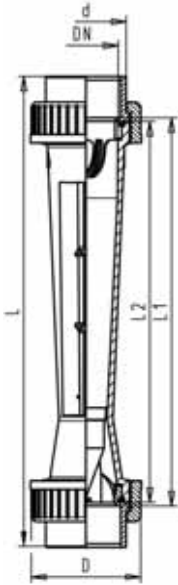

Variable area flow meter type 335 Float in PVDF with magnet With solvent cement sockets PVC-U metric

Model:

- Suitable limit switches see accessories for variable area flow meters

Scale range [l/h]	d [mm]	DN [mm]	Taper tube in PVC-U transp. O- Rings in EPDM Code	Taper tube in Polyamid O-rings in EPDM Code	Taper tube in Polysulfone O- rings in EPDM Code	kg
50 - 500	32	25	198 335 100	198 335 120	198 335 140	0.440
100 - 1000	32	25	198 335 101	198 335 121	198 335 141	0.452
150 - 1500	40	32	198 335 102	198 335 122	198 335 142	0.604
250 - 2500	40	32	198 335 103	198 335 123	198 335 143	0.585
200 - 2000	50	40	198 335 104	198 335 124	198 335 144	0.900
300 - 3000	50	40	198 335 105	198 335 125	198 335 145	1.035
600 - 6000	50	40	198 335 106	198 335 126	198 335 146	0.881
600 - 6000	63	50	198 335 107	198 335 127	198 335 147	1.225
1000 - 10000	63	50	198 335 108	198 335 128	198 335 148	1.248
1500 - 15000	63	50	198 335 109	198 335 129	198 335 149	1.409
2000 - 20000	75	65	198 335 110	198 335 130	198 335 150	2.441
3000 - 30000	75	65	198 335 111	198 335 131	198 335 151	2.377
8000 - 60000	75	65	198 335 112	198 335 132	198 335 152	2.150

Scale range [l/h]	D [mm]	L [mm]	L1 [mm]	L2 [mm]	G [inch]
50 - 500	58	385	341	335	1 ½
100 - 1000	58	385	341	335	1 ½
150 - 1500	72	393	341	335	2
250 - 2500	72	393	341	335	2
200 - 2000	83	403	341	335	2 ¼
300 - 3000	83	403	341	335	2 ¼
600 - 6000	83	403	341	335	2 ¼
600 - 6000	101	417	341	335	2 ¾
1000 - 10000	101	417	341	335	2 ¾
1500 - 15000	101	417	341	335	2 ¾
2000 - 20000	135	429	341	335	3 ½
3000 - 30000	135	429	341	335	3 ½
8000 - 60000	135	429	341	335	3 ½

Variable area flow meter type 350
Float in PVDF without magnet
With solvent cement sockets PVC-U metric

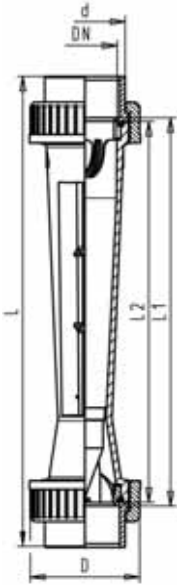

Scale range [l/h]	d [mm]	DN [mm]	Taper tube in PVC-U transp. O- rings in EPDM Code	Taper tube in Polyamid O-rings in EPDM Code	Taper tube in Polysulfone O- rings in EPDM Code	kg
50 - 500	32	25	198 350 000	198 350 020	198 350 040	0.487
100 - 1000	32	25	198 350 001	198 350 021	198 350 041	0.474
150 - 1500	40	32	198 350 002	198 350 022	198 350 042	0.614
250 - 2500	40	32	198 350 003	198 350 023	198 350 043	0.688
200 - 2000	50	40	198 350 004	198 350 024	198 350 044	0.962
300 - 3000	50	40	198 350 005	198 350 025	198 350 045	0.989
600 - 6000	50	40	198 350 006	198 350 026	198 350 046	0.953
600 - 6000	63	50	198 350 007	198 350 027	198 350 047	1.335
1000 - 10000	63	50	198 350 008	198 350 028	198 350 048	1.343
1500 - 15000	63	50	198 350 009	198 350 029	198 350 049	1.315
2000 - 20000	75	65	198 350 010	198 350 030	198 350 050	2.486
3000 - 30000	75	65	198 350 011	198 350 031	198 350 051	2.770
8000 - 60000	75	65	198 350 012	198 350 032	198 350 052	2.244

Scale range [l/h]	D [mm]	L [mm]	L1 [mm]	L2 [mm]	G [inch]
50 - 500	58	400	356	350	1 ½
100 - 1000	58	400	356	350	1 ½
150 - 1500	72	408	356	350	2
250 - 2500	72	408	356	350	2
200 - 2000	83	418	356	350	2 ¼
300 - 3000	83	418	356	350	2 ¼
600 - 6000	83	418	356	350	2 ¼
600 - 6000	101	432	356	350	2 ¾
1000 - 10000	101	432	356	350	2 ¾
1500 - 15000	101	432	356	350	2 ¾
2000 - 20000	135	444	356	350	3 ½
3000 - 30000	135	444	356	350	3 ½
8000 - 60000	135	444	356	350	3 ½

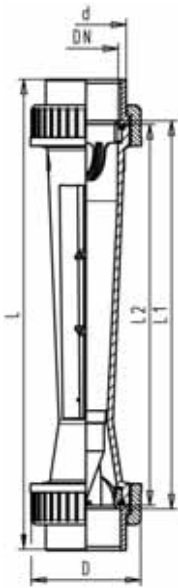

Variable area flow meter type 350 Float in PVDF with magnet With solvent cement sockets PVC-U metric

Model:

- Suitable limit switches see accessories for variable area flow meters

Scale range [l/h]	d [mm]	DN [mm]	Taper tube in PVC-U transp. O- Rings in EPDM Code	Taper tube in Polyamid O-rings in EPDM Code	Taper tube in Polysulfone O- rings in EPDM Code	kg
50 - 500	32	25	198 350 100	198 350 120	198 350 140	0.440
100 - 1000	32	25	198 350 101	198 350 121	198 350 141	0.440
150 - 1500	40	32	198 350 102	198 350 122	198 350 142	0.615
250 - 2500	40	32	198 350 103	198 350 123	198 350 143	0.620
200 - 2000	50	40	198 350 104	198 350 124	198 350 144	0.900
300 - 3000	50	40	198 350 105	198 350 125	198 350 145	0.900
600 - 6000	50	40	198 350 106	198 350 126	198 350 146	0.900
600 - 6000	63	50	198 350 107	198 350 127	198 350 147	1.320
1000 - 10000	63	50	198 350 108	198 350 128	198 350 148	1.320
1500 - 15000	63	50	198 350 109	198 350 129	198 350 149	1.320
2000 - 20000	75	65	198 350 110	198 350 130	198 350 150	2.150
3000 - 30000	75	65	198 350 111	198 350 131	198 350 151	2.150
8000 - 60000	75	65	198 350 112	198 350 132	198 350 152	2.150

Scale range [l/h]	D [mm]	L [mm]	L1 [mm]	L2 [mm]	G [inch]
50 - 500	58	400	356	350	1 ½
100 - 1000	58	400	356	350	1 ½
150 - 1500	72	408	356	350	2
250 - 2500	72	408	356	350	2
200 - 2000	83	418	356	350	2 ¼
300 - 3000	83	418	356	350	2 ¼
600 - 6000	83	418	356	350	2 ¼
600 - 6000	101	432	356	350	2 ¾
1000 - 10000	101	432	356	350	2 ¾
1500 - 15000	101	432	356	350	2 ¾
2000 - 20000	135	444	356	350	3 ½
3000 - 30000	135	444	356	350	3 ½
8000 - 60000	135	444	356	350	3 ½



Short version Float in PVDF without magnet With solvent cement sockets PVC-U metric

Model:

- Union nuts and valve ends in other materials on request

Type	d [mm]	DN [mm]	Scale range [l/h]	Taper tube in Polysulfone O- rings in EPDM Code	Taper tube in PVC-U transp. O- rings in EPDM Code	kg
SK 50	16	10	2.5 - 25	198 801 880	198 803 310	0.081
SK 51	16	10	5 - 50	198 801 881	198 803 311	0.079
SK 52	16	10	10 - 100	198 801 882	198 803 312	0.079
SK 60	20	15	8 - 80	198 801 883	198 803 313	0.127
SK 61	20	15	15 - 150	198 801 884	198 803 314	0.130
SK 62	20	15	20 - 200	198 801 885	198 803 315	0.125
SK 70	32	25	15 - 150	198 801 886	198 803 316	0.256
SK 71	32	25	30 - 300	198 801 887	198 803 317	0.254
SK 72	32	25	50 - 500	198 801 888	198 803 318	0.244
SK 73	32	25	100 - 1000	198 801 889	198 803 319	0.242

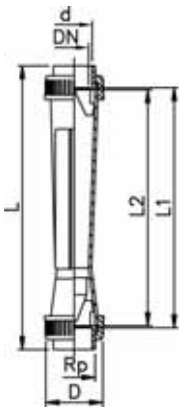

Type	D [mm]	L [mm]	L1 [mm]	L2 [mm]	Rp [inch]
SK 50	35	199	171	165	3/8
SK 51	35	199	171	165	3/8
SK 52	35	199	171	165	3/8
SK 60	43	223	191	185	1/2
SK 61	43	223	191	185	1/2
SK 62	43	223	191	185	1/2
SK 70	60	250	206	200	1
SK 71	60	250	206	200	1
SK 72	60	250	206	200	1
SK 73	60	250	206	200	1

Short version Float in PVDF with magnet With solvent cement sockets PVC-U metric

Model:

- Union nuts and valve ends in other materials on request
- Suitable limit switches see accessories for variable area flow meters

Type	d [mm]	DN [mm]	Scale range [l/h]	Taper tube in Polysulfone O- rings in EPDM Code	Taper tube in PVC-U transp. O- rings in EPDM Code	kg
SK 500	16	10	2.5 - 25	198 801 890	198 803 320	0.081
SK 510	16	10	5 - 50	198 801 891	198 803 321	0.080
SK 520	16	10	10 - 100	198 801 892	198 803 322	0.079
SK 600	20	15	8 - 80	198 801 893	198 803 323	0.129
SK 610	20	15	15 - 150	198 801 894	198 803 324	0.128
SK 620	20	15	20 - 200	198 801 895	198 803 325	0.125
SK 700	32	25	15 - 150	198 801 896	198 803 326	0.301
SK 710	32	25	30 - 300	198 801 897	198 803 327	0.255
SK 720	32	25	50 - 500	198 801 898	198 803 328	0.248
SK 730	32	25	100 - 1000	198 801 899	198 803 329	0.242

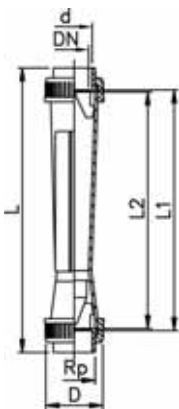

Type	D [mm]	L [mm]	L1 [mm]	L2 [mm]	Rp [inch]
SK 500	35	199	171	165	3/8
SK 510	35	199	171	165	3/8
SK 520	35	199	171	165	3/8
SK 600	43	223	191	185	1/2
SK 610	43	223	191	185	1/2
SK 620	43	223	191	185	1/2
SK 700	60	250	206	200	1

table continued next page

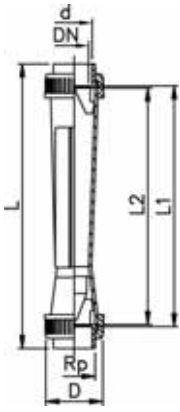

Type	D [mm]	L [mm]	L1 [mm]	L2 [mm]	Rp [inch]
SK 710	60	250	206	200	1
SK 720	60	250	206	200	1
SK 730	60	250	206	200	1

**Special version PVDF-HP
Float in PTFE without magnet
With fusion spigots BCF/IR**



Type	d [mm]	DN [mm]	Scale range [l/h]	Scale range [gal/min]	Taper tube in Polysulfone O- rings in FPM Code	kg
SK 70	32	25	68 - 204	0.3-0.9	198 807 209	0.383
SK 71	32	25	90 - 295	0.4-1.3	198 807 210	0.387
SK 73	32	25	136 - 795	0.6-3.5	198 807 202	0.401
SK 20	50	40	568 - 2273	2.5-10.0	198 807 203	1.030
SK 21	50	40	909 - 4091	4.0-18.0	198 807 204	0.978
SK 30	63	50	1000 - 8142	4.4-36.0	198 807 205	1.500
SK 31	63	50	1000 - 9091	4.4-40.0	198 807 206	1.500
SK 40	75	65	1848 - 11364	8.0-50.0	198 807 207	2.500
SK 41	75	65	2273 - 16364	10.0-72.0	198 807 208	2.500



Type	D [mm]	L [mm]	L1 [mm]	L2 [mm]	Rp [inch]
SK 70	60	318		200	1
SK 71	60	318		200	1
SK 73	60	318		200	1
SK 20	83	466		335	1 ½
SK 21	83	466		335	1 ½
SK 30	103	472		335	2
SK 31	103	472		335	2
SK 40	122	495		335	2 ½
SK 41	122	495		335	2 ½

Special version PVDF Float in PVDF (red) without magnet

Dimension L and L1 only valid for socket connection
Dimension L2 describes taper tube length

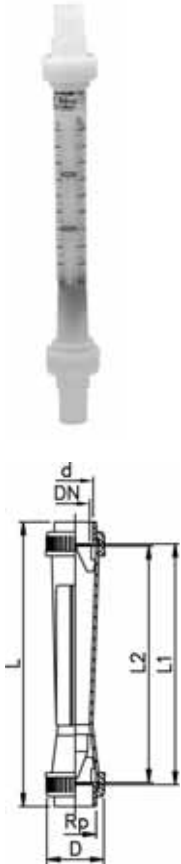

Type	d [mm]	DN [mm]	Scale range [l/h]	Taper tube in PVDF O-rings in FPM fusion sock- et Code	Taper tube in PVDF O-rings in FPM IR fusion spigot Code	kg
SK 10	32	25	50 - 500	198 806 466	198 803 905	0.520
SK 11	32	25	100 - 1000	198 806 467	198 803 906	0.520
SK 20	50	40	200 - 2000	198 806 468	198 803 907	1.220
SK 21	50	40	300 - 3000	198 806 469	198 803 908	1.220
SK 30	63	50	600 - 6000	198 806 470	198 803 909	1.785
SK 31	63	50	1200 - 12000	198 806 471	198 803 910	1.680
SK 40	75	65	2000 - 20000	-	198 803 911	2.900
SK 41	75	65	3000 - 30000	-	198 803 912	2.900

Type	D [mm]	L [mm]	L (IR-SS) [mm]	L1 [mm]	L2 [mm]	Rp [inch]
SK 10	60	385	443	341	335	1
SK 11	60	385	443	341	335	1
SK 20	83	403	459	341	335	1 ½
SK 21	83	403	459	341	335	1 ½
SK 30	103	417	461	339	335	2
SK 31	103	417	461	339	335	2
SK 40	122	429	453	341	335	2 ½
SK 41	122	429	453	341	335	2 ½

Valve ends and Nuts



Union nut (5)

Union nut not useable for the special version with taper tube in PVDF



d [mm]	Inch	DN [mm]	PVC-U Code	PVC-C Code	ABS Code	PP-H Code
32	1	25	721 890 008	723 690 008	729 890 408	727 890 408
40	1 ¼	32	721 890 009	723 690 009	729 890 409	727 890 409
50	1 ½	40	721 890 010	723 690 010	729 890 410	727 890 410
63	2	50	721 890 011	723 690 011	729 890 411	727 890 411
75	2 ½	65	198 806 429	-	-	198 806 421

d [mm]	Inch	DN [mm]	PVDF Code	kg
32	1	25	735 690 408	0.035
40	1 ¼	32	735 690 409	0.065
50	1 ½	40	735 690 410	0.093
63	2	50	735 690 411	0.144
75	2 ½	65	198 806 422	0.337



Union end / Socket (6)

For DN65 PVDF only spigot

d [mm]	Inch	DN [mm]	PVC-U Code	PVC-C Code	ABS Code	PP-H Code	PVDF Code
32	1	25	721 500 108	723 800 108	729 800 108	727 500 108	735 600 108
40	1 ¼	32	721 500 109	723 800 109	729 800 109	727 500 109	735 600 109
50	1 ½	40	721 500 110	723 800 110	729 800 110	727 500 110	735 600 110
63	2	50	721 500 111	723 800 111	729 800 111	727 500 111	735 600 111
75	2 ½	65	721 600 112	700 253 867	700 246 112	700 253 866	-

d [mm]	Inch	DN [mm]	PE80 Code	kg
32	1	25	734 600 108	0.015
40	1 ¼	32	734 600 109	0.026
50	1 ½	40	734 600 110	0.025
63	2	50	734 600 111	0.044
75	2 ½	65	700 246 419	0.163



Union end / Spigot (6)

d [mm]	Inch	DN [mm]	PP-H Code	PVDF Code	PE100 Code	kg
32	1	25	727 508 508	735 608 608	753 608 608	0.027
40	1 ¼	32	727 508 509	735 608 609	753 608 609	0.042
50	1 ½	40	727 508 510	735 608 610	753 608 610	0.060
63	2	50	727 508 511	735 608 611	753 608 611	0.102
75	2 ½	65	700 256 401	175 483 013	700 246 420	0.300

Accessories

4-20 mA sensor

For type 335 and type 350



Type	d [mm]	DN [mm]	Corresponds to water scale [l/h]	Code	kg
GK 15	32	25	50-500	198 335 962	0.150
GK 15	32	25	100-1000	198 335 963	0.150
GK 15	40	32	150-1500	198 335 964	0.150
GK 15	40	32	250-2500	198 335 965	0.150
GK 15	50	40	200-2000	198 335 966	0.150
GK 15	50	40	300-3000	198 335 967	0.150
GK 15	50	40	600-6000	198 335 968	0.150
GK 15	63	50	600-6000	198 335 969	0.150
GK 15	63	50	1000-10000	198 335 991	0.150
GK 15	63	50	1500-15000	198 335 992	0.150
GK 15	75	65	2000-20000	198 335 993	0.150
GK 15	75	65	3000-30000	198 335 994	0.150
GK 15	75	65	8000-60000	198 335 995	0.150



Accessories

Limit contacts GK10/GK11

For type 335/350 and short version

Type	Code	kg
GK10 (min.)	198 335 960	0.035
GK11 (max.)	198 335 961	0.034

Special scale for type 335/350

l/h

d [mm]	DN [mm]	Scale range [l/h]	Code	kg
32	25	50-500	198 335 861	0.050
32	25	100-1000	198 335 862	0.050
40	32	150-1500	198 335 863	0.050
40	32	250-2500	198 335 864	0.050
50	40	200-2000	198 335 865	0.050
50	40	300-3000	198 335 866	0.050
50	40	600-6000	198 335 867	0.050
63	50	600-6000	198 335 868	0.050
63	50	1000-10000	198 335 869	0.050
63	50	1500-15000	198 335 870	0.050
75	65	2000-20000	198 335 871	0.050
75	65	3000-30000	198 335 872	0.050
75	65	8000-60000	198 335 873	0.050

Special scale for type 335/350

% for H₂O

d [mm]	DN [mm]	Scale range	Corresponds to water scale [l/h]	Code	kg
32	25	10-100 %	50-500	198 335 084	0.050
32	25	10-100 %	100-1000	198 335 083	0.003
40	32	10-100 %	150-1500	198 335 069	0.050
40	32	10-100 %	250-2500	198 335 068	0.050
50	40	10-100 %	200-2000	198 335 054	0.050
50	40	10-100 %	300-3000	198 335 053	0.001
50	40	10-100 %	600-6000	198 335 039	0.050
63	50	10-100 %	600-6000	198 335 038	0.002
63	50	10-100 %	1000-10000	198 335 037	0.001
63	50	10-100 %	1500-15000	198 335 036	0.050
75	65	10-100 %	2000-20000	198 335 035	0.050
75	65	10-100 %	3000-30000	198 335 034	0.050
75	65	13.3-100 %	8000-60000	198 335 033	0.050

Special scale for type 335/350

m³/h

d [mm]	DN [mm]	Scale range [m ³ /h]	Corresponds to wa- ter scale [l/h]	Code	kg
32	25	0.05 - 0.5	50 - 500	198 335 655	0.050
32	25	0.1 - 1	100 - 1000	198 335 656	0.050
40	32	0.15 - 1.5	150 - 1500	198 335 657	0.050

table continued next page

d [mm]	DN [mm]	Scale range [m³/h]	Corresponds to wa- ter scale [l/h]	Code	kg
40	32	0.25 - 2.5	250 - 2500	198 335 658	0.050
50	40	0.2 - 2.0	200 - 2000	198 335 659	0.050
50	40	0.3 - 3	300 - 3000	198 335 660	0.050
50	40	0.6 - 6	600 - 6000	198 335 661	0.050
63	50	0.6 - 6	600 - 6000	198 335 662	0.050
63	50	1 - 10	1000 - 10000	198 335 663	0.050
63	50	1.5 - 15	1500 - 15000	198 335 664	0.050
75	65	2 - 20	2000 - 20000	198 335 665	0.050
75	65	3 - 30	3000 - 30000	198 335 666	0.008
75	65	8 - 60	8000 - 60000	198 335 667	0.050

Special scale for type 335/350 Imp. GPM

d [mm]	DN [mm]	Scale range [gal/min]	Corresponds to water scale [l/h]	Code	kg
32	25	0,183 - 1,83	50-500	198 335 670	0.050
32	25	0,366 - 3,66	100-1000	198 335 671	0.050
40	32	0,55 - 5,5	150-1500	198 335 672	0.050
40	32	0,916 - 9,16	250-2500	198 335 673	0.050
50	40	0,733 - 7,33	200-2000	198 335 674	0.050
50	40	1,09 - 10,9	300-3000	198 335 675	0.050
50	40	2,19 - 21,9	600-6000	198 335 676	0.050
63	50	2,2 - 22	600-6000	198 335 677	0.050
63	50	3,66 - 36,6	1000-10000	198 335 678	0.050
63	50	5,49 - 54,9	1500-15000	198 335 679	0.050
75	65	7,32 - 73,2	2000-20000	198 335 680	0.050
75	65	10,98 - 109,8	3000-30000	198 335 681	0.050
75	65	29,28 - 219,6	8000-60000	198 335 682	0.050

Special scale for type 335/350 US GPM

d [mm]	DN [mm]	Scale range [gal/min]	Corresponds to wa- ter scale [l/h]	Code	kg
32	25	0.22 - 2.2	50 - 500	198 335 685	0.050
32	25	0.44 - 4.4	100 - 1000	198 335 686	0.050
40	32	0.66 - 6.6	150 - 1500	198 335 687	0.001
40	32	1.1 - 11	250 - 2500	198 335 688	0.050
50	40	0.88 - 8.8	200 - 2000	198 335 689	0.001
50	40	1.32 - 13.2	300 - 3000	198 335 690	0.050
50	40	2.64 - 26.4	600 - 6000	198 335 691	0.002
63	50	2.64 - 26.4	600 - 6000	198 335 692	0.050
63	50	4.40 - 44.02	1000 - 10000	198 335 693	0.002
63	50	6.60 - 66.04	1500 - 15000	198 335 694	0.050
75	65	8.80 - 88	2000 - 20000	198 335 695	0.001
75	65	13.20 - 132	3000 - 30000	198 335 696	0.001
75	65	35.2 - 264	8000 - 60000	198 335 697	0.050

Special scale for type 335/350 Air/0bar/Nm³/h

d [mm]	DN [mm]	Scale range [m³/h]	Corresponds to wa- ter scale [l/h]	Code	kg
32	25	1.5 - 14	50 - 500	198 350 655	0.001
32	25	2.5 - 29	100 - 1000	198 350 656	0.050
40	32	4 - 45	150 - 1500	198 350 657	0.050
40	32	7 - 79	250 - 2500	198 350 658	0.050
50	40	6 - 58	200 - 2000	198 350 659	0.050
50	40	9 - 108	300 - 3000	198 350 660	0.001

table continued next page

d [mm]	DN [mm]	Scale range [m ² /h]	Corresponds to wa- ter scale [l/h]	Code	kg
50	40	17 - 174	600 - 6000	198 350 661	0.050
63	50	17 - 175	600 - 6000	198 350 662	0.050
63	50	29 - 301	1000 - 10000	198 350 663	0.050
63	50	53 - 405	1500 - 15000	198 350 664	0.050
75	65	55 - 545	2000 - 20000	198 350 665	0.050
75	65	80 - 758	3000 - 30000	198 350 666	0.050
75	65	-	8000 - 60000	198 350 667	0.050

Special scale for type 335/350 HCl 30-33% l/h

d [mm]	DN [mm]	Scale range [l/h]	Corresponds to water scale [l/h]	Code	kg
32	25	20 - 405	50-500	198 350 670	0.050
32	25	55 - 866	100-1000	198 350 671	0.001
40	32	90 - 1340	150-1500	198 350 672	0.050
40	32	165 - 2310	250-2500	198 350 673	0.050
50	40	115 - 1660	200-2000	198 350 674	0.050
50	40	190 - 3050	300-3000	198 350 675	0.050
50	40	420 - 4900	600-6000	198 350 676	0.001
63	50	430 - 5090	600-6000	198 350 677	0.050
63	50	750 - 9460	1000-10000	198 350 678	0.050
63	50	1415 - 11570	1500-15000	198 350 679	0.050
75	65	1500 - 17300	2000-20000	198 350 680	0.050
75	65	2175 - 24120	3000-30000	198 350 681	0.050
75	65	-	8000-60000	198 350 682	0.050

Special scale for type 335/350 NaOH 30% l/h

d [mm]	DN [mm]	Scale range [l/h]	Corresponds to water scale [l/h]	Code	kg
32	25	4 - 226	50-500	198 350 685	0.050
32	25	15 - 600	100-1000	198 350 686	0.050
40	32	30 - 970	150-1500	198 350 687	0.050
40	32	70 - 1800	250-2500	198 350 688	0.050
50	40	35 - 1240	200-2000	198 350 689	0.002
50	40	75 - 2370	300-3000	198 350 690	0.050
50	40	230 - 4000	600-6000	198 350 691	0.050
63	50	240 - 4700	600-6000	198 350 692	0.050
63	50	475 - 7340	1000-10000	198 350 693	0.050
63	50	1030 - 10330	1500-15000	198 350 694	0.050
75	65	915 - 11720	2000-20000	198 350 695	0.050
75	65	1195 - 16040	3000-30000	198 350 696	0.050
75	65	-	8000-60000	198 350 697	0.050

Special scale for type 335/350 NaOH 50% l/h

d [mm]	DN [mm]	Scale range [l/h]	Corresponds to water scale [l/h]	Code	kg
32	25	1 - 55	50-500	198 350 755	0.050
32	25	3 - 192	100-1000	198 350 756	0.050
40	32	6 - 365	150-1500	198 350 757	0.050
40	32	15 - 770	250-2500	198 350 758	0.050
50	40	8 - 520	200-2000	198 350 759	0.050
50	40	15 - 1170	300-3000	198 350 760	0.050
50	40	50 - 2270	600-6000	198 350 761	0.002
63	50	55 - 2300	600-6000	198 350 762	0.050
63	50	140 - 4340	1000-10000	198 350 763	0.050
63	50	420 - 5820	1500-15000	198 350 764	0.050

table continued next page

d [mm]	DN [mm]	Scale range [l/h]	Corresponds to water scale [l/h]	Code	kg
75	65	245 - 7590	2000-20000	198 350 765	0.050
75	65	400 - 11120	3000-30000	198 350 766	0.050
75	65	-	8000-60000	198 350 767	0.050

Special scale for short version Water l/h

Type	Scale range [l/h]	Code	kg
SK 50 / 500	2.5 - 25.0	198 801 386	0.001
SK 51 / 510	5.0 - 50.0	198 801 387	0.001
SK 52 / 520	10.0 - 100.0	198 801 388	0.001
SK 60 / 600	8.0 - 80.0	198 801 389	0.001
SK 61 / 610	15.0 - 150.0	198 801 390	0.001
SK 62 / 620	20.0 - 200.0	198 801 391	0.001
SK 70 / 700	15.0 - 150.0	198 801 392	0.001
SK 71 / 710	30.0 - 300.0	198 801 393	0.001
SK 72 / 720	50.0 - 500.0	198 801 394	0.001
SK 73 / 730	100.0 - 1000.0	198 801 395	0.001

Special scale for short version US GPM

Type	Scale range [gal/min]	Code	kg
SK 50 / 500	0,01 - 0,11	198 801 961	0.001
SK 51 / 510	0,02 - 0,22	198 801 962	0.001
SK 52 / 520	0,04 - 0,44	198 801 963	0.001
SK 60 / 600	0,03 - 0,35	198 801 964	0.001
SK 61 / 610	0,06 - 0,66	198 801 965	0.001
SK 62 / 620	0,08 - 0,88	198 801 966	0.001
SK 70 / 700	0,06 - 0,66	198 801 967	0.001
SK 71 / 710	0,13 - 1,32	198 801 968	0.001
SK 72 / 720	0,22 - 2,20	198 801 969	0.001
SK 73 / 730	0,44 - 4,40	198 801 970	0.001

Special scale for short version Air/0bar/Nm³/h

Type	Scale range [m ³ /h]	Code	kg
SK 50 / 500	0,5 - 0,95	198 801 308	0.001
SK 51 / 510	0,5 - 1,9	198 801 309	0.001
SK 52 / 520	0,8 - 3,0	198 801 310	0.001
SK 60 / 600	0,6 - 2,8	198 801 311	0.001
SK 61 / 610	1,4 - 5,6	198 801 312	0.001
SK 62 / 620	1,5 - 7,0	198 801 313	0.001
SK 70 / 700	1,0 - 6,5	198 801 314	0.001
SK 71 / 710	1,5 - 11,0	198 801 315	0.001
SK 72 / 720	3,0 - 18,0	198 801 316	0.001
SK 73 / 730	6,0 - 30,0	198 801 317	0.001

Special scale for short version HCl 30 - 33% l/h

Type	Scale range [l/h]	Code	kg
SK 50 / 500	2,5 - 20	198 806 511	0.001
SK 51 / 510	5 - 40	198 806 512	0.001
SK 52 / 520	10 - 85	198 806 513	0.001
SK 60 / 600	8 - 70	198 806 514	0.001
SK 61 / 610	15 - 125	198 806 515	0.001

table continued next page

Type	Scale range [l/h]	Code	kg
SK 62 / 620	20 - 170	198 806 516	0.001
SK 70 / 700	5 - 125	198 806 517	0.001
SK 71 / 710	30 - 260	198 806 518	0.001
SK 72 / 720	50 - 425	198 806 519	0.001
SK 73 / 730	100 - 850	198 806 520	0.001

Special scale for short version NaOH 30% l/h

Type	Scale range [l/h]	Code	kg
SK 50 / 500	0.2 - 5	198 806 521	0.001
SK 51 / 510	1 - 14	198 806 522	0.001
SK 52 / 520	3 - 35	198 806 523	0.001
SK 60 / 600	2 - 23	198 806 524	0.002
SK 61 / 610	3 - 55	198 806 525	0.001
SK 62 / 620	5 - 80	198 806 526	0.001
SK 70 / 700	3 - 55	198 806 527	0.001
SK 71 / 710	6 - 130	198 806 528	0.001
SK 72 / 720	10 - 250	198 806 529	0.002
SK 73 / 730	40 - 590	198 806 530	0.001

Special scale for short version NaOH 50% l/h

Type	Scale range [l/h]	Code	kg
SK 60 / 600	0,2 - 3,5	198 806 531	0.001
SK 61 / 610	0,5 - 10	198 806 532	0.001
SK 62 / 620	0,5 - 16	198 806 533	0.001
SK 70 / 700	0,5 - 11	198 806 534	0.001
SK 71 / 710	1 - 33	198 806 535	0.001
SK 72 / 720	2 - 80	198 806 536	0.001
SK 73 / 730	10 - 220	198 806 537	0.001

Spare part for variable area flow meter SK10-SK41/SK100-SK410 Standard version float PTFE Without magnet

Type	d [mm]	DN [mm]	Code	kg
SK 20	50	40	198 807 167	0.096
SK 21	50	40	198 807 171	0.270
SK 30	63	50	198 807 168	0.170
SK 31	63	50	198 807 172	0.450
SK 40	75	65	198 807 169	0.179
SK 41	75	65	198 807 170	0.171

Process control valves

PROGEF Standard Pressure reducing valve type V182/82 With fusion spigots metric

Model:

- Material: PP-H

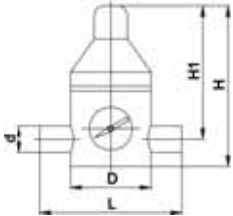

Type	d [mm]	DN [mm]	Pressure range [bar]	EPDM Code	FPM Code	PTFE Code	kg
V182	16	10	0.5 - 10	199 041 621	199 041 631		0.540
V182	20	15	0.5 - 10	199 041 622	199 041 632		0.540
V182	25	20	0.5 - 10	199 041 623	199 041 633		1.020
V182	32	25	0.5 - 10	199 041 624	199 041 634		1.300
V182	40	32	0.5 - 10	199 041 625	199 041 635		2.240
V182	50	40	0.5 - 10	199 041 626	199 041 636		2.240
V182	63	50	0.5 - 10	199 041 377	199 041 378		5.700
V82	75	65	0.5 - 6	199 041 039	-	199 041 049	7.900
V82	90	80	0.5 - 6	199 041 040	-	199 041 050	12.900
V82	110	100	0.5 - 4	199 041 041	-	199 041 051	23.300

Type	D [mm]	L [mm]	H [mm]	H1 [mm]
V182	70	134	130	100
V182	70	134	130	100
V182	100	174	180	134
V182	100	174	180	134
V182	130	224	230	175
V182	130	224	230	175
V182	150	260	285	210
V82	200	300	350	250
V82	250	360	425	305
V82	300	420	495	345

PROGEF Standard Pressure reducing valve type V182/82 With butt fusion spigots IR metric

Model:

- Material: PP-H

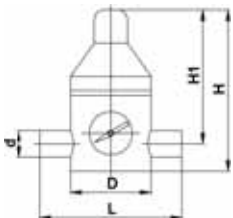

Type	d [mm]	DN [mm]	Pressure range [bar]	EPDM Code	FPM Code	PTFE Code	kg
V182	16	10	0.5 - 10	199 041 641	199 041 651		
V182	20	15	0.5 - 10	199 041 642	199 041 652		0.550
V182	25	20	0.5 - 10	199 041 643	199 041 653		1.030
V182	32	25	0.5 - 10	199 041 644	199 041 654		1.030
V182	40	32	0.5 - 10	199 041 645	199 041 655		2.240
V182	50	40	0.5 - 10	199 041 646	199 041 656		2.240
V182	63	50	0.5 - 10	199 041 351	199 041 358		3.960
V82	75	65	0.5 - 6	199 041 417		199 041 427	7.910
V82	90	80	0.5 - 6	199 041 418		199 041 428	12.910
V82	110	100	0.5 - 4	199 041 419		199 041 429	23.300

Type	D [mm]	L [mm]	H [mm]	H1 [mm]
V182	70		130	100
V182	70	150	130	100
V182	100	190	180	134
V182	100	190	180	134
V182	130	240	230	175
V182	130	240	230	175
V182	150	260	285	210

table continued next page

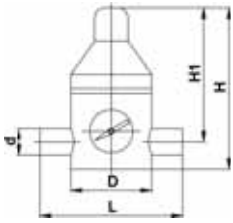

Type	D [mm]	L [mm]	H [mm]	H1 [mm]
V82				
V82				
V82				



PROGEF Standard Pressure reducing valve type V782 With fusion spigots metric

Model:

- Material: PP-H

d [mm]	DN [mm]	Pressure range [bar]	EPDM Code	PTFE Code	kg	D [mm]	L [mm]	L1 [mm]	H [mm]	H1 [mm]
16	10	0.5 - 10	199 041 072	199 041 078	0.450	83	134	102	138	48
20	15	0.5 - 10	199 041 073	199 041 079	0.460	83	134	102	138	48
25	20	0.5 - 10	199 041 074	199 041 080	1.240	113	154	110	205	65
32	25	0.5 - 10	199 041 075	199 041 081	1.250	113	154	110	205	65
40	32	0.5 - 10	199 041 076	199 041 082	3.910	165	224	162	248	95
50	40	0.5 - 10	199 041 077	199 041 083	3.930	165	224	162	248	95

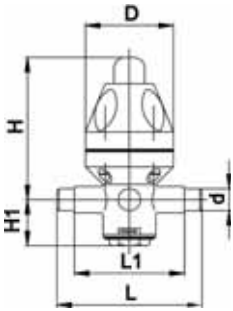

PROGEF Standard Pressure reducing valve type V782 With butt fusion spigots IR metric

Model:

- Material: PP-H

d [mm]	DN [mm]	Pressure range [bar]	EPDM Code	PTFE Code	kg	D [mm]	L [mm]	L1 [mm]	H [mm]	H1 [mm]
20	15	0.5 - 10	199 041 299	199 041 404	0.460	83	172	102	138	48
25	20	0.5 - 10	199 041 300	199 041 405	1.240	113	190	110	205	65
32	25	0.5 - 10	199 041 301	199 041 406	1.250	113	190	110	205	65
40	32	0.5 - 10	199 041 302	199 041 407	3.910	165	262	162	248	95
50	40	0.5 - 10	199 041 303	199 041 408	4.760	165	262	162	248	95

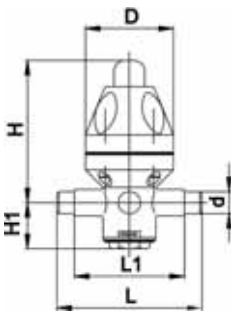



PROGEF Standard Pressure retaining valve type V786 With fusion spigots metric

Model:

- Material: PP-H

d [mm]	DN [mm]	Pressure range [bar]	EPDM Code	PTFE Code	kg	D [mm]	L [mm]	L1 [mm]	H [mm]	H1 [mm]
16	10	0.5 - 10	199 041 102	199 041 108	0.450	83	134	102	138	38
20	15	0.5 - 10	199 041 103	199 041 109	0.450	83	134	102	138	38
25	20	0.5 - 10	199 041 104	199 041 110	1.280	112	154	110	205	55
32	25	0.5 - 10	199 041 105	199 041 111	1.280	112	154	110	205	55
40	32	0.5 - 4	199 041 106	199 041 112	3.480	165	224	162	248	85
50	40	0.5 - 4	199 041 107	199 041 113	4.692	165	224	162	248	85

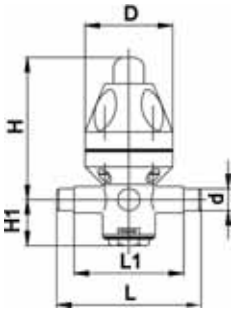

PROGEF Standard Pressure retaining valve type V786 With butt fusion spigots IR metric

Model:

- Material: PP-H

d [mm]	DN [mm]	Pressure range [bar]	EPDM Code	PTFE Code	kg	D [mm]	L [mm]	L1 [mm]	H [mm]	H1 [mm]
20	15	0.5 - 10	199 041 431	199 041 437	0.450	83	172	102	138	38
25	20	0.5 - 10	199 041 432	199 041 438	1.280	112	190	110	205	55
32	25	0.5 - 10	199 041 433	199 041 439	1.280	112	190	110	205	55
40	32	0.5 - 4	199 041 434	199 041 440	3.480	165	262	162	248	85
50	40	0.5 - 4	199 041 435	199 041 441	3.480	165	262	162	248	85

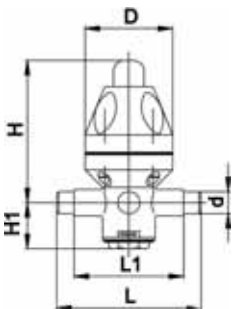



PROGEF Standard Gauge guard type Z700 With manometer

Model:

- Material: PP-H

d [mm]	Pressure range [bar]	Pressure range [psi]	PTFE Code	kg	G_R	D [mm]	D1 [mm]	H [mm]	H1 [mm]	H2 [mm]
25	0.0 - 10	0.0 - 145.03	199 041 002	0.250	¼	72	63	129	71	15
25	0.0 - 6	0.0 - 87.02	199 041 294	0.250	¼	72	63	129	71	15
32	0.0 - 10	0.0 - 145.03	199 041 003	0.542	½	100	100	210	90	22
32	0.0 - 6	0.0 - 87.02	199 041 295	0.540	½	100	100	210	90	22

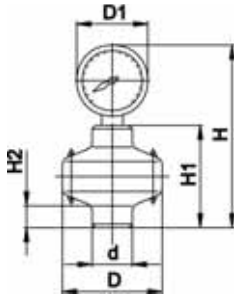

PROGEF Standard Gauge guard type Z701 Without manometer

Model:

- Material: PP-H

d [mm]	PTFE Code	kg	G_R	D [mm]	H1 [mm]	H2 [mm]
25	199 041 008	0.108	¼	72	71	15
32	199 041 009	0.183	½	100	90	22

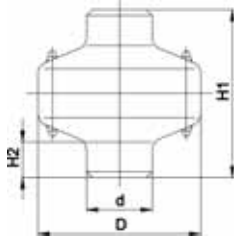

PROGEF Standard Water jet suction pump type P20

Model:

- Material: PP-H
- DN 10-20: BSP parallel female thread
- DN 25-50: Fusion socket metric
- DN 65-80: Fusion spigot metric

d [mm]	DN [mm]	PN	EPDM Code	kg	G [inch]	G1 [inch]	L [mm]	L1 [mm]	L2 [mm]	H [mm]	H1 [mm]
16	10	10	199 041 129	0.100	R 3/4	R 3/4		110	40		35
20	15	10	199 041 130	0.170	R 1	R 3/4		125	40		35
25	20	10	199 041 131	0.270	R 1 1/4	R 3/4		145	45		45
32	25	10	199 041 132	0.400	R 1 1/2	R 1 1/2	245	195		96	71
40	32	10	199 041 133	0.604	R 2	R 2	297	239		116	87
50	40	10	199 041 134	1.090	R 2 1/4	R 2 1/4	369	301		139	105

table continued next page

d [mm]	DN [mm]	PN	EPDM Code	kg	G [inch]	G1 [inch]	L [mm]	L1 [mm]	L2 [mm]	H [mm]	H1 [mm]
63	50	10	199 041 135	1.930	R 2 3/4	R 2 3/4	433	351		169	128
75	65	10	199 041 136	1.603	R 1	-	388				115
90	80	10	199 041 137	2.570	R 2 3/4	-	465				149

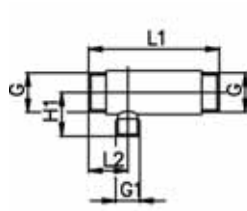

DN 10 - 20

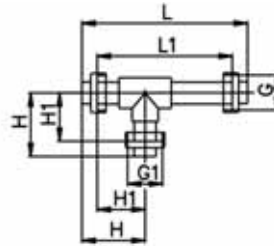

DN 25 - 50

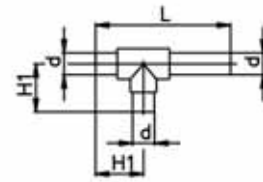

DN 65 - 80



PROGEF Standard Throttle valve type V251 With fusion sockets metric

Model:

- Material: PP-H

d [mm]	DN [mm]	PN	EPDM Code	FPM Code	kg	D [mm]	L [mm]	H [mm]	H1 [mm]
16	10	10	199 041 217	199 041 224	0.032	29	47	57	45
20	15	10	199 041 218	199 041 225	0.051	35	55	66	51
25	20	10	199 041 219	199 041 226	0.080	40	66	80	63
32	25	10	199 041 220	199 041 227	0.135	47	80	96	75
40	32	10	199 041 221	199 041 228	0.243	56	100	111	86
50	40	10	199 041 222	199 041 229	0.419	70	120	133	101
63	50	10	199 041 223	199 041 230	0.600	88	146	158	118

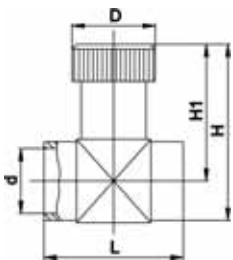

PROGEF Standard Float valve type V140 With fusion spigots metric

Model:

- Material: PP-H
- Lever 1:10

d [mm]	DN [mm]	PN	EPDM Code	FPM Code	kg
16	10	6	199 041 165	199 041 174	0.460
20	15	6	199 041 166	199 041 175	0.500
25	20	6	199 041 167	199 041 176	1.382
32	25	6	199 041 168	199 041 177	2.140
40	32	6	199 041 169	199 041 178	3.250
50	40	6	199 041 170	199 041 179	4.400
63	50	6	199 041 171	199 041 180	5.800
75	65	6	199 041 172	199 041 181	7.400
90	80	6	199 041 173	199 041 182	8.200

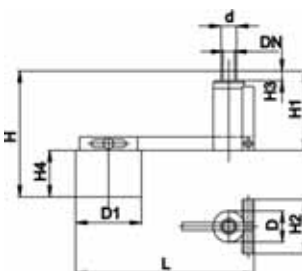

d [mm]	D [mm]	D1 [mm]	L [mm]	H [mm]	H1 [mm]	H2 [mm]	H3 [mm]	H4 [mm]
16	45	125	380	270	120	80	14	130
20	45	125	380	270	120	80	16	130
25	65	200	530	340	160	110	19	170
32	65	200	530	345	165	110	22	170
40	90	225	720	440	210	130	26	210
50	90	225	720	445	215	130	31	210

table continued next page

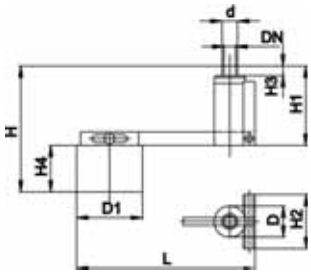

d [mm]	D [mm]	D1 [mm]	L [mm]	H [mm]	H1 [mm]	H2 [mm]	H3 [mm]	H4 [mm]	
63	130	315	975	595	255	160	38	290	
75	130	315	975	600	260	160	44	290	
90	150	355	1140	640	290	180	51	340	

Solenoid valves

PROGEF Standard

Solenoid valve type 166

Function A straight-through valve 2/2 ways

Nominal voltage 24V DC

With G 1/4 line connection

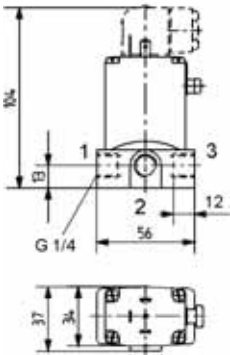
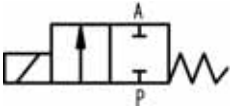

Model:

- Material: PP-H
- With manual override
- Electrical connection: cable plug
- Protection class IP 65

DN [mm]	D1_G [inch]	Function	PN [bar]	kv-value ($\Delta p=1$ bar) [l/min]	EPDM Code	FPM Code	kg
3	1/4	A	0.0 - 8.0	4	199 166 000	199 166 005	0.298
4	1/4	A	0.0 - 4.0	5	199 166 001	199 166 006	1.100
5	1/4	A	0.0 - 3.0	6	199 166 002	199 166 007	0.292

PROGEF Standard

Solenoid valve type 166

Function A straight-through valve 2/2 ways

Nominal voltage 230V 50Hz $\pm 10\%$

With G 1/4 line connection

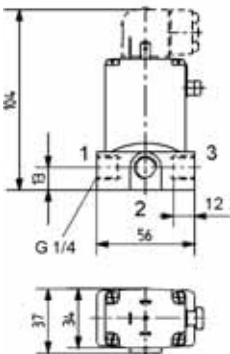
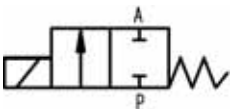

Model:

- Material: PP-H
- With manual override
- Electrical connection: cable plug
- Protection class IP 65

DN [mm]	D1_G [inch]	Function	PN [bar]	kv-value ($\Delta p=1$ bar) [l/min]	EPDM Code	FPM Code	kg
3	1/4	A	0.0 - 10.0	4	199 166 010	199 166 015	1.100
4	1/4	A	0.0 - 5.0	5	199 166 011	199 166 016	1.100
5	1/4	A	0.0 - 4.5	6	199 166 012	199 166 017	1.100



PROGEF Standard
Solenoid valve type 166
Function E mixing valve 3/2 ways
Nominal voltage 24V DC
With G 1/4 line connection

Model:

- Material: PP-H
- With manual override
- Electrical connection: cable plug
- Protection class IP 65

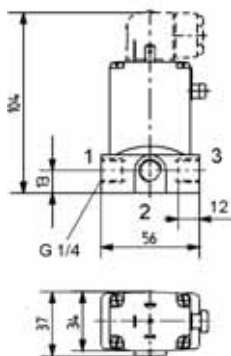

DN [mm]	D1_G [inch]	Function	PN [bar]	kv-value ($\Delta p=1$ bar) [l/min]	EPDM Code	FPM Code	kg
3	1/4	E	0.0 - 4.0	4	199 166 150	199 166 155	1.100
4	1/4	E	0.0 - 2.0	5	199 166 151	199 166 156	1.100



PROGEF Standard
Solenoid valve type 166
Function E mixing valve 3/2 ways
Nominal voltage 230V 50Hz $\pm 10\%$
With G 1/4 line connection

Model:

- Material: PP-H
- With manual override
- Electrical connection: cable plug
- Protection class IP 65

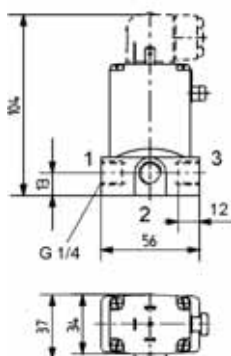

DN [mm]	D1_G [inch]	Function	PN [bar]	kv-value ($\Delta p=1$ bar) [l/min]	EPDM Code	FPM Code	kg
3	1/4	E	0.0 - 6.0	4	199 166 160	199 166 165	1.100
4	1/4	E	0.0 - 3.0	5	199 166 161	199 166 166	1.100



**PROGEF Standard
Solenoid valve type 166
Function F distribution valve 3/2 ways
Nominal voltage 24V DC
With G 1/4 line connection**

Model:

- Material: PP-H
- With manual override
- Electrical connection: cable plug
- Protection class IP 65

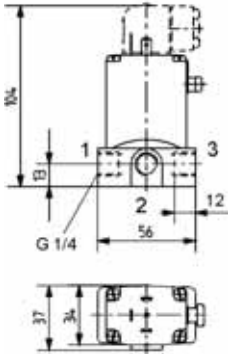
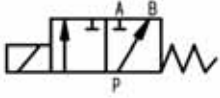

DN [mm]	D1_G [inch]	Function	PN [bar]	kv-value ($\Delta p=1$ bar) [l/min]	EPDM Code	FPM Code	kg
4	1/4	F	0.0 - 4.0	5	199 166 201	199 166 206	1.100



**PROGEF Standard
Solenoid valve type 166
Function F distribution valve 3/2 ways
Nominal voltage 230V 50Hz $\pm 10\%$
With G 1/4 line connection**

Model:

- Material: PP-H
- With manual override
- Electrical connection: cable plug
- Protection class IP 65

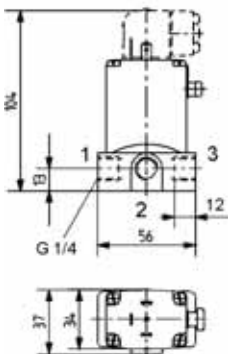
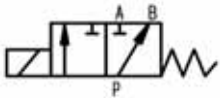

DN [mm]	D1_G [inch]	Function	PN [bar]	kv-value ($\Delta p=1$ bar) [l/min]	EPDM Code	FPM Code	kg
4	1/4	F	0.0 - 5.0	5	199 166 211	199 166 216	1.100

PROGEF® Natural



- Pipes
- Butt Fusion System

PROGEF® Natural (natural)

Pressure/temperature diagram for PP

PROGEF® Natural

The following pressure/temperature diagram for PROGEF® Natural pipes and fittings is valid for a lifetime of 25 years.

The design factor of 2.0 recommended by GF is incorporated.

It can be used for water or media resembling water, in other words, media which have no derating factor regarding the chemical resistance.

Remark: Please take into account the pressure/temperature diagrams for valves and special fittings. Because of the construction and/or sealing material used, differences are possible when compared with pipes and fittings. This information can be found in the planning fundamentals of the relevant types of valves, respectively special fittings.

Remark: Using PROGEF® Natural at higher temperatures can lead to a discoloration of the material.

In case of applications with temperatures in the range of the dotted lines please contact your GF representative.

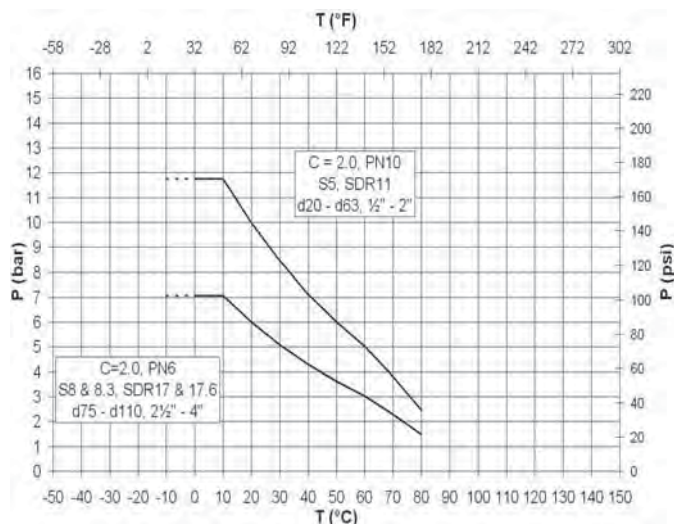

P Permissible pressure in bar, psi
T Temperature in °C, °F

PROGEF Natural – System Specification





Material	Polypropylene Random Copolymer
Colour	Unpigmented, translucent
Density	~0.90g/cm ³ [ISO 1183 / ASTM D 792]
Surface tension	30–35mJ/m ²
Linear expansion coefficient	0.15mm/m °K (DIN 53752)
E-modulus	900N/mm ² [ISO 527/ASTM D 790]
Thermal conductivity	0.23W/mK (EN 12664)
Surface resistivity	> 10 ¹⁶ Ω (IEC 60093)
Dimension	d20–d 110 in accordance with EN ISO 15494
Pressure Rating	Pipes/Fittings/Diaphragm valves: d20–d 63 SDR11, PN10, c=2.0 d75–d 110 SDR17.6, PN6, c=2.0
Temperature Rating	from 0 °C to 80 °C (<60 °C for valves) (32 °F–176 °F)
Production	Fittings/valves: injection moulded Pipes: extruded
Surface Finish	Inner surface Ra ≤ 1 µm (39 µin)
Marking	Fittings, pipes and valves are embossed with a permanent identification during the production process to ensure full traceability: Lot No Material Dimension Pressure Rating
Testing and Inspection (EN ISO 15494)	Inclusions Visual inspection Surface finish Dimension tolerance Pressure testing Full product range passed the Initial Type Test (ITT)
Approvals/Conformance ⁽¹⁾	FDA CFR 21 177.1520 USP 25 class VI (physiological non-toxic)
Welding Technology	BCF Plus, bead and crevice free fusion IR Plus, infrared fusion (DVS 2207-6) Butt fusion (DVS 2207-11)
Documentation ⁽²⁾	Certificate of Conformance with FDA, USP EN 10204 2.2 EN 10204 3.1 ASME BPE
Packing	Pipes: Capped & single bagged Fittings/valves: Multiple components single bagged in specified bag
Labeling	Brand Name Product Description Code Number Material Dimension CE-labeling ⁽³⁾ Approvals
Main Applications	Uses include cost effective, pure distribution of DI-water and critical biological fluids where chemical sanitisation is needed. Bead and Crevice Free jointing and minimal metallic leachout ensure the highest product quality. Highly resistant to impact, abrasion and many chemicals make it ideal for slurries transportation in the semiconductor industry.

⁽¹⁾ For thermoplastic material only

⁽²⁾ On request

⁽³⁾ From 2008 on

PROGEF Natural Pipes, Fittings, Unions, Flanges and Flange Adaptors

		Page
	Pipes	326
	Fittings for Butt Fusion	327
	Adaptor fittings for butt fusion	329
	Flange Adaptors, Flanges and Gaskets for Butt Fusion	334

68 48 01

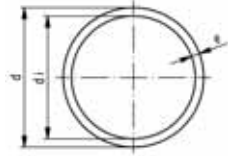

Pipes

PROGEF Natural S5/SDR11 (PN10)

Model:

- Material: PP-R unpigmented
- Colour: natural
- Length: Lengths of 5 m
- Bead and Crevice Free weldable with the new BCF® Plus fusion machine
- Infrared-(IR Plus®) compatible. Choose fusion parameters: PP-n (PP-R)
- Conventional butt-welding according to DVS 2207 part 11

d [mm]	Code	kg/m	e [mm]	di [mm]
20	168 480 151	0.107	1.9	16.2
25	168 480 152	0.164	2.3	20.4
32	168 480 153	0.261	2.9	26.2
40	168 480 154	0.412	3.7	32.6
50	168 480 155	0.638	4.6	40.8
63	168 480 156	1.010	5.8	51.4

Fittings for Butt Fusion

PROGEF Natural elbow 45° S5/SDR11

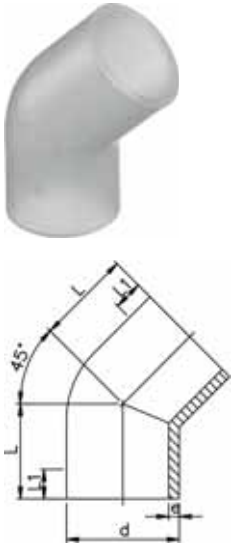

Model:

- Material: PP-R unpigmented
- Bead and Crevice Free weldable with the new BCF® Plus fusion machine
- Infrared-(IR Plus®) compatible. Choose fusion parameters: PP-n (PP-R)
- Conventional butt-welding according to DVS 2207 part 11

d [mm]	FM	Code	kg	L [mm]	L1 [mm]	e [mm]
20	BCF, IR	728 158 506	0.007	32	24	1.9
25	BCF, IR	728 158 507	0.002	34	25	2.3
32	BCF, IR	728 158 508	0.019	36	25	2.9
40	BCF, IR	728 158 509	0.037	39	25	3.7
50	BCF, IR	728 158 510	0.054	42	26	4.6
63	BCF, IR	728 158 511	0.097	47	29	5.8

PROGEF Natural bend 90° S5/SDR11 - 0.75d

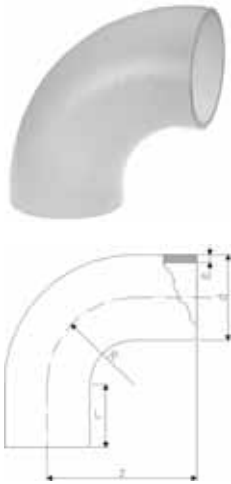

Model:

- Material: PP-R unpigmented
- Bead and Crevice Free weldable with the new BCF® Plus fusion machine
- Infrared-(IR Plus®) compatible. Choose fusion parameters: PP-n (PP-R)
- Conventional butt-welding according to DVS 2207 part 11

d [mm]	FM	Code	kg	z [mm]	L [mm]	R [mm]	e [mm]
20	IR, BCF	728 018 606	0.007	38	23	15	1.9
25	IR, BCF	728 018 607	0.012	42	23	19	2.3
32	IR, BCF	728 018 608	0.026	46	22	24	2.9
40	IR, BCF	728 018 609	0.038	51	21	30	3.7
50	IR, BCF	728 018 610	0.065	58	21	37	4.6
63	IR, BCF	728 018 611	0.115	66	21	45	5.8

PROGEF Natural tee 90° equal S5/SDR11

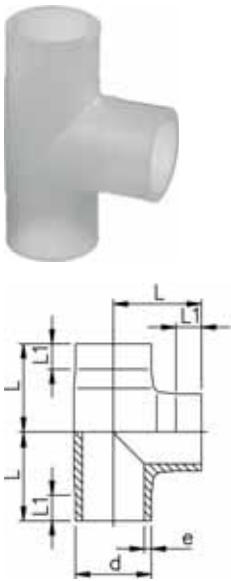

Model:

- Material: PP-R unpigmented
- Bead and Crevice Free weldable with the new BCF® Plus fusion machine
- Infrared-(IR Plus®) compatible. Choose fusion parameters: PP-n (PP-R)
- Conventional butt-welding according to DVS 2207 part 11

d [mm]	FM	Code	kg	L [mm]	L1 [mm]	e [mm]
20	BCF, IR	728 208 506	0.011	38	24	1.9
25	BCF, IR	728 208 507	0.019	42	26	2.3
32	BCF, IR	728 208 508	0.032	46	26	2.9
40	BCF, IR	728 208 509	0.059	51	23	3.7
50	BCF, IR	728 208 510	0.101	58	22	4.6
63	BCF, IR	728 208 511	0.182	66	20	5.8

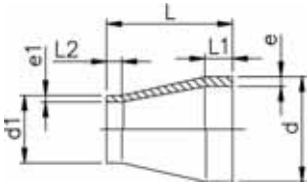

PROGEF Natural reducer S5/SDR11

Model:

- Material: PP-R unpigmented
- Bead and Crevice Free weldable with the new BCF® Plus fusion machine
- Infrared-(IR Plus®) compatible. Choose fusion parameters: PP-n (PP-R)
- Conventional butt-welding according to DVS 2207 part 11

d [mm]	d1 [mm]	FM	Code	kg	L [mm]	L1 [mm]	L2 [mm]	e [mm]	e1 [mm]
25	20	BCF, IR	728 908 537	0.007	50	20	20	2.3	1.9
32	20	BCF, IR	728 908 542	0.010	50	20	20	3.0	1.9
32	25	BCF, IR	728 908 541	0.011	50	20	20	3.0	2.3
40	20	BCF, IR	728 908 548	0.015	58	20	23	3.7	1.9
40	25	BCF, IR	728 908 547	0.016	55	20	20	3.7	2.3
40	32	BCF, IR	728 908 546	0.019	55	20	20	3.7	2.9
50	25	BCF, IR	728 908 554	0.025	60	20	20	4.6	2.3
50	32	BCF, IR	728 908 553	0.027	60	20	20	4.6	2.9
50	40	BCF, IR	728 908 552	0.030	60	20	20	4.6	3.7
63	32	BCF, IR	728 908 560	0.043	65	20	20	5.8	2.9
63	40	BCF, IR	728 908 559	0.047	65	20	20	5.8	3.7
63	50	BCF, IR	728 908 558	0.052	65	20	20	5.8	4.6

EPDM 28 51 85
FPM 28 52 85

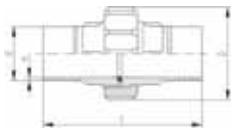

PROGEF Natural sanitary union S5/SDR11

Model:

- Material: PP-R unpigmented
- Bead and Crevice Free weldable with the new BCF® Plus fusion machine
- Infrared-(IR Plus®) compatible. Choose fusion parameters: PP-n (PP-R)
- Conventional butt-welding according to DVS 2207 part 11
- Only EPDM codes meet FDA compliance.

d [mm]	FM	EPDM Code	FPM Code	kg	D [mm]	L [mm]	L1 [mm]	L2 [mm]	e [mm]
20	BCF, IR	728 518 526	728 528 526	0.048	48	107	53	25	1.9
25	BCF, IR	728 518 527	728 528 527	0.076	58	113	56	25	2.3
32	BCF, IR	728 518 528	728 528 528	0.106	65	119	59	25	2.9
40	BCF, IR	728 518 529	728 528 529	0.147	79	126	63	25	3.7
50	BCF, IR	728 518 530	728 528 530	0.194	91	131	65	25	4.6
63	BCF, IR	728 518 531	728 528 531	0.343	111	137	68	25	5.8

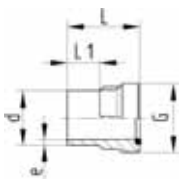

PROGEF Natural union bush S5/SDR11

Model:

- Material: PP-R unpigmented
- Bead and Crevice Free weldable with the new BCF® Plus fusion machine
- Infrared-(IR Plus®) compatible. Choose fusion parameters: PP-n (PP-R)
- Conventional butt-welding according to DVS 2207 part 11

d [mm]	PN	FM	Code	kg	G [inch]	L [mm]	L1 [mm]	e [mm]
20	10	BCF, IR	728 648 526	0.012	1	54	26	1.9
25	10	BCF, IR	728 648 527	0.020	1 1/4	57	26	2.3
32	10	BCF, IR	728 648 528	0.029	1 1/2	60	25	2.9
40	10	BCF, IR	728 648 529	0.047	2	63	25	3.7
50	10	BCF, IR	728 648 530	0.072	2 1/4	66	25	4.6
63	10	BCF, IR	728 648 531	0.104	2 3/4	69	25	5.8

Adaptor fittings for butt fusion

PROGEF Natural adaptor socket metric Rp

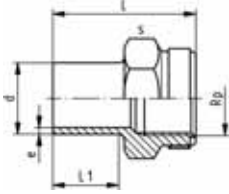

Model:

- Material: PP-R unpigmented
- With butt fusion spigot **SDR11** and BSP parallel female thread Rp, reinforced
- Connection to plastic or metal threads
- Reinforcing ring stainless (A2)
- Do not use thread sealing pastes that are harmful to PP

d [mm]	FM	Rp [inch]	PN	Code	kg	L [mm]	L1 [mm]	s [mm]	e [mm]
20	BCF, IR	½	10	728 918 056	0.014	49	28	32	1,9
25	BCF, IR	¾	10	728 918 057	0.022	51	28	36	2,3
32	BCF, IR	1	10	728 918 058	0.039	54	28	46	2,9
40	BCF, IR	1 ¼	10	728 918 059	0.057	56	28	55	3,7
50	BCF, IR	1 ½	10	728 918 060	0.085	60	28	64	4,6
63	BCF, IR	2	10	728 918 061	0.140	62	28	80	5,8

PROGEF Natural adaptor socket metric NPT

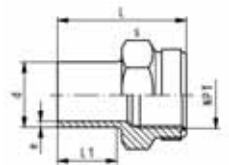

Model:

- Material: PP-R unpigmented
- With butt fusion spigot **SDR11** and NPT tapered female thread, reinforced
- Connection to plastic or metal threads
- Reinforcing ring stainless (A2)
- Do not use thread sealing pastes that are harmful to PP
- Install with low mechanical stress and avoid large cyclic temperature changes

d [mm]	FM	NPT [inch]	PN	Code	kg	L [mm]	L1 [mm]	s [mm]	e [mm]
20	BCF, IR	½	10	728 914 056	0.016	49	28	32	1,9
25	BCF, IR	¾	10	728 914 057	0.019	51	28	36	2,3
32	BCF, IR	1	10	728 914 058	0.039	54	28	46	2,9
40	BCF, IR	1 ¼	10	728 914 059	0.052	56	28	55	3,7
50	BCF, IR	1 ½	10	728 914 060	0.085	60	28	64	4,6
63	BCF, IR	2	10	728 914 061	0.140	62	28	80	5,8

PROGEF Natural adaptor nipple metric R

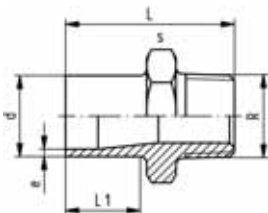

Model:

- Material: PP-R unpigmented
- With butt fusion spigot SDR11 and tapered male thread
- Connection to plastic threads only
- Do not use thread sealing pastes that are harmful to PP
- Install with low mechanical stress and avoid large cyclic temperature changes

d [mm]	FM	R [inch]	PN	Code	kg	L [mm]	L1 [mm]	s [mm]	e [mm]
20	BCF, IR	½	10	728 918 106	0.013	51	28	32	1,9
25	BCF, IR	¾	10	728 918 107	0.017	52	28	36	2,3
32	BCF, IR	1	10	728 918 108	0.027	55	28	46	2,9
40	BCF, IR	1 ¼	10	728 918 109	0.037	58	28	55	3,7
50	BCF, IR	1 ½	10	728 918 110	0.052	60	28	65	4,6
63	BCF, IR	2	10	728 918 111	0.092	67	28	80	5,8

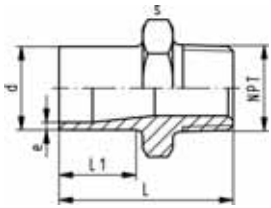

PROGEF Natural adaptor nipple metric NPT

Model:

- Material: PP-R unpigmented
- With butt fusion spigot **SDR11** and NPT tapered male thread
- Connection to plastic threads only
- Do not use thread sealing pastes that are harmful to PP
- Install with low mechanical stress and avoid large cyclic temperature changes

d [mm]	NPT [inch]	PN	FM	Code	kg	L [mm]	L1 [mm]	s [mm]	e [mm]
20	½	10	BCF, IR	728 914 106	0.013	51	28	32	1.9
25	¾	10	BCF, IR	728 914 107	0.017	52	28	36	2.3
32	1	10	BCF, IR	728 914 108	0.027	55	28	46	2.9
40	1 ¼	10	BCF, IR	728 914 109	0.039	58	28	55	3.7
50	1 ½	10	BCF, IR	728 914 110	0.054	60	28	65	4.6
63	2	10	BCF, IR	728 914 111	0.093	67	28	80	5.8

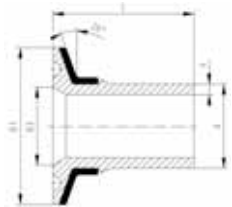

PROGEF Natural sanitary adaptor Connection to ISO 1127

Model:

- Material: PP-R unpigmented
- Conventional butt-welding according to DVS 2207 part 11
- Infrared-(IR Plus®) compatible. Choose fusion parameters: PP-n (PP-R)
- Bead and Crevice Free weldable with the new BCF® Plus fusion machine
- Stainless steel reinforcement ring

d [mm]	FM	DN [mm]	PN	Code	kg	D1 [mm]	D3 [mm]	L [mm]	e [mm]
20	BCF, IR	15	10	728 598 006	0.031	50	18	49.0	1,9
25	BCF, IR	20	10	728 598 008	0.029	50	23	49.5	2,3
25	BCF, IR	25	10	728 598 009	0.029	50	29	49.5	2,3
32	BCF, IR	25	10	728 598 010	0.030	50	29	53.0	2,9
40	BCF, IR	32	10	728 598 014	0.054	64	38	54.0	3,7
50	BCF, IR	40	10	728 598 016	0.064	64	44	61.0	4,6
63	BCF, IR	50	10	728 598 018	0.097	77	56	67.0	5,8

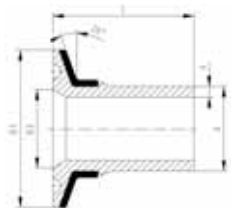

PROGEF Natural sanitary adaptor Connection to DIN 32676

Model:

- Material: PP-R unpigmented
- Conventional butt-welding according to DVS 2207 part 11
- Infrared-(IR Plus®) compatible. Choose fusion parameters: PP-n (PP-R)
- Bead and Crevice Free weldable with the new BCF® Plus fusion machine
- Stainless steel reinforcement ring

d [mm]	FM	DN [mm]	PN	Code	kg	D1 [mm]	D3 [mm]	L [mm]	e [mm]
20	BCF, IR	15	10	728 598 056	0.013	34	16	49.0	1,9
20	BCF, IR	20	10	728 598 057	0.013	34	20	49.0	1,9
25	BCF, IR	25	10	728 598 059	0.032	50	26	49.5	2,3
32	BCF, IR	32	10	728 598 062	0.031	50	32	53.0	2,9
40	BCF, IR	40	10	728 598 065	0.036	50	38	54.0	3,7
50	BCF, IR	50	10	728 598 067	0.060	64	50	61.0	4,6

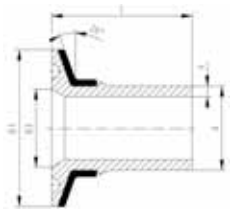

PROGEF Natural sanitary adaptor Connection to DIN 3017

Model:

- Material: PP-R unpigmented
- Conventional butt-welding according to DVS 2207 part 11
- Infrared-(IR Plus®) compatible. Choose fusion parameters: PP-n (PP-R)
- Bead and Crevice Free weldable with the new BCF® Plus fusion machine
- Stainless steel reinforcement ring

d [mm]	FM	DN [mm]	PN	Code	kg	D1 [mm]	D3 [mm]	L [mm]	e [mm]
25	BCF, IR	25	10	728 598 259	0.031	50	22	49.5	2,3
32	BCF, IR	32	10	728 598 262	0.031	50	32	53.0	2,9
40	BCF, IR	40	10	728 598 265	0.033	50	35	54.0	3,7
50	BCF, IR	50	10	728 598 267	0.061	64	49	61.0	4,6
63	BCF, IR	65	10	728 598 269	0.093	78	60	67.0	5,8

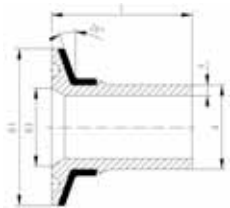

PROGEF Natural sanitary adaptor Connection to ISO 2852

Model:

- Material: PP-R unpigmented
- Conventional butt-welding according to DVS 2207 part 11
- Infrared-(IR Plus®) compatible. Choose fusion parameters: PP-n (PP-R)
- Bead and Crevice Free weldable with the new BCF® Plus fusion machine
- Stainless steel reinforcement ring

d [mm]	FM	DN [mm]	PN	Code	kg	D1 [mm]	D3 [mm]	L [mm]	e [mm]
25	BCF, IR	25	10	728 598 309	0.027	51	22	50	2,3
32	BCF, IR	32	10	728 598 312	0.031	51	32	53	2,9
40	BCF, IR	40	10	728 598 315	0.033	51	35	54	3,7
50	BCF, IR	50	10	728 598 317	0.061	64	49	61	4,6
63	BCF, IR	65	10	728 598 319	0.093	78	60	67	5,8

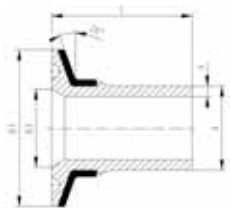

PROGEF Natural sanitary adaptor Connection to ASME BPE

Model:

- Material: PP-R unpigmented
- Conventional butt-welding according to DVS 2207 part 11
- Infrared-(IR Plus®) compatible. Choose fusion parameters: PP-n (PP-R)
- Bead and Crevice Free weldable with the new BCF® Plus fusion machine
- Stainless steel reinforcement ring

* Without stainless steel reinforcement ring

d [mm]	FM	Inch	PN	Code	kg	D1 [mm]	D3 [mm]	L [mm]	e [mm]
* 20	BCF, IR	3/4	10	728 598 357	0.005	25	16	49	1.9
25	BCF, IR	1	10	728 598 359	0.029	51	22	50	2.3
32	BCF, IR	1 1/4	10	728 598 362	0.030	51	35	53	2.9
40	BCF, IR	1 1/2	10	728 598 365	0.037	51	35	54	3.7
50	BCF, IR	2	10	728 598 367	0.063	64	48	61	4.6
63	BCF, IR	2 1/2	10	728 598 369	0.096	78	60	67	5.8

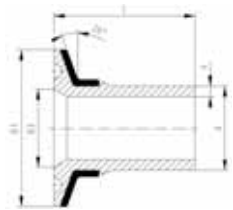

PROGEF Natural sanitary adaptor Connection to JIS G3447

Model:

- Material: PP-R unpigmented
- Conventional butt-welding according to DVS 2207 part 11
- Infrared-(IR Plus®) compatible. Choose fusion parameters: PP-n (PP-R)
- Bead and Crevice Free weldable with the new BCF® Plus fusion machine
- Stainless steel reinforcement ring

d [mm]	FM	DN	PN	Code	kg	D1 [mm]	D3 [mm]	L [mm]	e [mm]
20	BCF, IR	15 A	10	728 598 406	0.014	34	18	49.0	1,9
25	BCF, IR	1 S	10	728 598 408	0.032	50	23	49.5	2,3
32	BCF, IR	1 1/4 S	10	728 598 410	0.033	50	30	53.0	2,9
40	BCF, IR	1 1/2 S	10	728 598 414	0.033	50	35	54.0	3,7
50	BCF, IR	2 S	10	728 598 416	0.061	64	48	61.0	4,6
63	BCF, IR	2 1/2 S	10	728 598 418	0.093	78	60	67.0	5,8

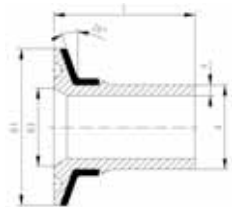

PROGEF Natural sanitary adaptor Connection to 3A standard

Model:

- Material: PP-R unpigmented
- Conventional butt-welding according to DVS 2207 part 11
- Infrared-(IR Plus®) compatible. Choose fusion parameters: PP-n (PP-R)
- Bead and Crevice Free weldable with the new BCF® Plus fusion machine
- Stainless steel reinforcement ring

* Without stainless steel reinforcement ring

d [mm]	FM	Inch	PN	Code	kg	D1 [mm]	D3 [mm]	L [mm]	e [mm]
* 20	BCF, IR	3/4	10	728 598 207	0.006	25	16	49.0	1,9
25	BCF, IR	1	10	728 598 209	0.031	50	22	49.5	2,3
32	BCF, IR	1 1/2	10	728 598 213	0.032	50	35	53.0	2,9
40	BCF, IR	1 1/2	10	728 598 215	0.033	50	35	54.0	3,7
50	BCF, IR	2	10	728 598 217	0.062	64	48	61.0	4,6
63	BCF, IR	2 1/2	10	728 598 219	0.093	78	60	67.0	5,8

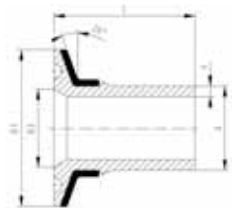

PROGEF Natural sanitary adaptor Connection to membrane manometer

Model:

- Material: PP-R unpigmented
- Conventional butt-welding according to DVS 2207 part 11
- Infrared-(IR Plus®) compatible. Choose fusion parameters: PP-n (PP-R)
- Bead and Crevice Free weldable with the new BCF® Plus fusion machine
- Stainless steel reinforcement ring

d [mm]	FM	DN [mm]	PN	Code	kg	e [mm]	D1 [mm]	D3 [mm]	L [mm]
20	BCF, IR	15	10	728 598 516	0.029	1,9	50	34	49
25	BCF, IR	20	10	728 598 518	0.027	2,3	50	34	50
32	BCF, IR	25	10	728 598 520	0.032	2,9	50	34	53

28 31 81

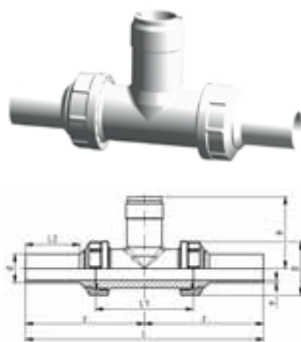

PROGEF Natural installation fitting type 318 For butt fusion systems metric

Model:

- Material: PP-H
- Threaded outlet 1 ¼" NPSM
- Union end with butt fusion spigot PP-R

Range of use:

- compatible signet flow sensors: type 2551, 2537, 515, 8510, 2536, 8512
- compatible signet pH/ORP sensors: type 2724, 2725, 2726

Attention:

- sensor length depends on installation fitting

d [mm]	DN [mm]	PN	FM	EPDM Code	FPM Code	kg	
20	15	10	BCF, IR	728 318 106	728 318 136	0.250	
25	20	10	BCF, IR	728 318 107	728 318 137	0.190	
32	25	10	BCF, IR	728 318 108	728 318 138	0.250	
40	32	10	BCF, IR	728 318 109	728 318 139	0.356	
50	40	10	BCF, IR	728 318 110	728 318 140	0.510	
63	50	10	BCF, IR	728 318 111	728 318 141	0.800	

d [mm]	D [mm]	z [mm]	L [mm]	L1 [mm]	L2 [mm]	H [mm]	e [mm]	Sensor Type	
20	45	99	198	90	38	76	1.9	flow X0, pH XX	
25	55	107	214	100	42	78	2.3	flow X0, pH XX	
32	62	115	230	110	41	81	2.9	flow X0, pH XX	
40	75	118	236	110	42	85	3.7	flow X0, pH XX	
50	84	126	252	120	44	89	4.6	flow X0, pH XX	
63	101	134	268	130	45	95	5.8	flow X0, pH XX	

27 31 80

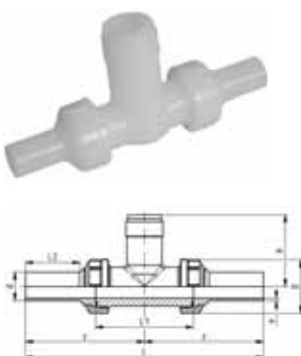

PROGEF Natural installation fitting type 318 For butt fusion systems metric

Model:

- Body and union nut PVDF
- Threaded outlet 1 ¼" NPSM
- Union end with butt fusion spigot PP-R

Range of use:

- compatible signet flow sensors: type 2551, 2537, 515, 8510, 2536, 8512
- compatible signet pH/ORP sensors: type 2724, 2725, 2726

Attention:

- sensor length depends on installation fitting

d [mm]	DN [mm]	PN	FM	EPDM Code	FPM Code	kg	
20	15	10	BCF, IR	728 318 006	728 318 036	0.250	
25	20	10	BCF, IR	728 318 007	728 318 037	0.355	
32	25	10	BCF, IR	728 318 008	728 318 038	0.427	
40	32	10	BCF, IR	728 318 009	728 318 039	0.700	
50	40	10	BCF, IR	728 318 010	728 318 040	0.850	
63	50	10	BCF, IR	728 318 011	728 318 041	1.182	

d [mm]	D [mm]	z [mm]	L [mm]	L1 [mm]	L2 [mm]	H [mm]	e [mm]	Sensor Type	
20	45	99	198	90	38	76	1.9	flow X0, pH XX	
25	55	107	214	100	42	78	2.3	flow X0, pH XX	
32	62	115	230	110	41	81	2.9	flow X0, pH XX	
40	75	118	236	110	42	85	3.7	flow X0, pH XX	
50	84	126	252	120	44	89	4.6	flow X0, pH XX	
63	101	134	268	130	45	95	5.8	flow X0, pH XX	

Flange Adaptors, Flanges and Gaskets for Butt Fusion

PROGEF Natural flange adaptor S5/SDR11 Combined jointing face: flat and serrated

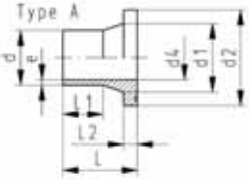

Model:

- Material: PP-R unpigmented
- Conventional butt-welding according to DVS 2207 part 11
- Bead and Crevice Free weldable with the new BCF® Plus fusion machine
- Infrared-(IR Plus®) compatible. Choose fusion parameters: PP-n (PP-R)
- Gasket: Profile flange gasket EPDM No. 48 44 07, FPM No. 49 44 07

d [mm]	DN [mm]	FM	Code	kg	d1 [mm]	d2 [mm]	d4 [mm]	L [mm]	L1 [mm]	L2 [mm]	e [mm]
20	15	WNF/IR	728 798 706	0.015	27	45	16	50	29	7	1.9
25	20	WNF/IR	728 798 707	0.028	33	58	20	52	27	9	2.3
32	25	WNF/IR	728 798 708	0.042	40	68	26	54	28	10	3.0
40	32	WNF/IR	728 798 709	0.064	50	78	32	56	25	11	3.7
50	40	WNF/IR	728 798 710	0.092	61	88	40	62	32	12	4.6
63	50	WNF/IR	728 798 711	0.142	75	102	51	68	38	14	5.8

Flange Adapter - ANSI Serrated, PN 10, Natural PP

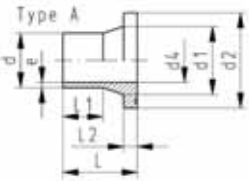

d [mm]	FM	Code	kg	e [mm]	d1 [mm]	d2 [mm]	d4 [mm]	L [mm]	L1 [mm]	L2 [mm]
20	WNF/IR	728 798 706	0.015	1.9	27	45	16	50	29	7
25	BCF, IR	728 798 657	0.028	2.3	33	54	20	52	27	9
32	BCF, IR	728 798 658	0.042	3.0	40	63	26	54	28	10
40	BCF, IR	728 798 659	0.064	3.7	50	73	32	56	25	11
50	BCF, IR	728 798 660	0.091	4.6	61	82	40	62	32	12
63	WNF/IR	728 798 711	0.142	5.8	75	102	51	68	38	14
75	IR	728 798 787	0.202	4.5	89	122	66	70	16	
90	IR	728 798 788	0.271	5.4	105	138	79	79	17	
110	IR	728 798 789	0.354	6.6	125	158	96	82	18	

27 70 04
27 70 05

Backing flange PP-V For butt fusion systems metric

Model:

- Modern full-plastic flange PP-GF (30 % glass-fibre reinforced)
- With V-groove which applies force evenly on collar
- With integrated bolt retainers as an assembly aid
- UV-resistant. Applicable for outside applications
- Connecting dimension: ISO 7005, EN 1092, BS 4504, DIN 2501
- **Bolt circle PN 10**

* Combined version, metric-ANSI

AL: number of holes

1) Suitable for socket- and butt fusion systems (no pictograph on flange)

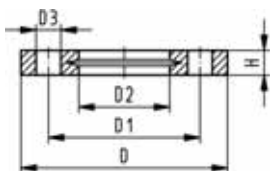

d [mm]	DN [mm]	PN	Code	kg	D [mm]	D1 [mm]	D2 [mm]	D3 [mm]	H [mm]	AL	SC
1) 20	15	16	727 700 406	0.093	95	65.0	28	14	16	4	M12
1) 25	20	16	727 700 407	0.120	105	75.0	34	14	17	4	M12
1) 32	25	16	727 700 408	0.151	115	85.0	42	14	18	4	M12
1) 40	32	16	727 700 409	0.244	140	100.0	51	18	20	4	M16
1) 50	40	16	727 700 410	0.297	150	110.0	62	18	22	4	M16
1) 63	50	16	727 700 411	0.362	165	125.0	78	18	24	4	M16

27 70 14
27 70 15

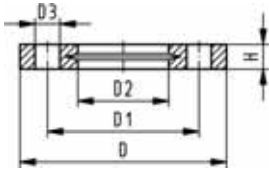

Backing flange PP-V For butt fusion systems Inch ANSI

Model:

- Modern full-plastic flange PP-GF (30 % glass-fibre reinforced)
- With V-groove which applies force evenly on collar
- With integrated bolt-fixing as an assembly aid
- UV-resistant. Applicable for outside applications
- Connecting dimension: ANSI/ASME B 16.5 class 150, ASTM D 4024, BS 1560, BS EN 1759
- **Bolt circle class 150**

1) Suitable for socket- and butt fusion systems (no pictograph on flange)

AL: number of holes

* Combined version, metric-ANSI

Inch	DN [mm]	d [mm]	PN	Code	kg	D [mm]	D1 [mm]	D2 [mm]	D3 [mm]	H [mm]	AL	SC
1/2	15	20	16	727 701 406	0.091	95	60.0	28	16	16	4	M12
3/4	20	25	16	727 701 407	0.120	105	70.0	34	16	17	4	M12
1	25	32	16	727 701 408	0.147	115	79.0	42	16	18	4	M12
1 1/4	32	40	16	727 701 409	0.246	140	89.0	51	16	20	4	M16
1 1/2	40	50	16	727 701 410	0.299	150	98.0	62	16	22	4	M16
2	50	63	16	727 701 411	0.361	165	121.0	78	19	24	4	M16
2 1/2	65	75	16	727 701 412	0.492	185	140.0	92	19	26	4	M16
3	80	90	16	727 701 513	0.607	200	152.0	108	19	27	4	M16
4	100	110	16	727 701 514	0.736	229	190.0	128	19	28	8	M16
10	250	250	16	727 701 521	2.241	406	362.0	288	26	38	12	M20
10	250	280	16	727 701 522	2.173	406	362.0	294	26	38	12	M20
12	300	315	16	727 701 523	3.627	483	432.0	338	26	42	12	M20

27 70 02
27 70 03

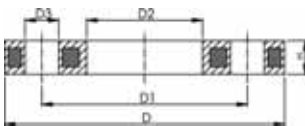

Backing flange PP-Steel For butt fusion systems metric

Model:

- Material: PP (30 % glass-fibre reinforced) with steel ring
- UV-resistant. Applicable for outside applications
- Connecting dimension: ISO 7005, EN 1092, BS 4504, DIN 2501
- **Bolt circle PN 10**

AL: number of holes

d [mm]	DN [mm]	PN	Code	kg	D [mm]	D1 [mm]	D2 [mm]	D3 [mm]	H [mm]	AL	SC
20	15	16	727 700 206	0.216	95	65	28	14	12	4	M12
25	20	16	727 700 207	0.279	105	75	34	14	12	4	M12
32	25	16	727 700 208	0.429	115	85	42	14	16	4	M12
40	32	16	727 700 209	0.621	140	100	51	18	16	4	M16
50	40	16	727 700 210	0.722	150	110	62	18	20	4	M16
63	50	16	727 700 211	1.084	165	125	78	18	20	4	M16

27 70 12

Backing flange PP-Steel For butt fusion systems Inch ANSI

Model:

- Material: PP (30 % glass-fibre reinforced) with steel ring
- UV-resistant. Applicable for outside applications
- Connecting dimension: ANSI/ASME B 16.5 class 150, ASTM D 4024, BS 1560, BS EN 1759
- **Bolt circle class 150**

AL: number of holes

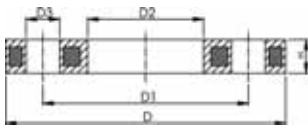

d [inch]	DN [mm]	d [mm]	PN	Code	kg	D1 [mm]	D2 [mm]	D3 [mm]	D [mm]	H [mm]	AL	SC
1/2	15	20	16	727 701 206	0.213	60	28	16	95	12	4	M12
3/4	20	25	16	727 701 207	0.260	70	34	16	105	12	4	M12
1	25	32	16	727 701 208	0.416	79	42	16	115	16	4	M12
1 1/4	32	40	16	727 701 209	0.730	89	51	16	140	16	4	M16
1 1/2	40	50	16	727 701 210	0.809	98	62	16	150	18	4	M16
2	50	63	16	727 701 211	0.866	121	78	19	165	18	4	M16
2 1/2	65	75	16	727 701 212	1.117	140	92	19	185	18	4	M16
3	80	90	16	727 701 313	1.499	152	108	19	200	20	4	M16
4	100	110	16	727 701 314	1.739	190	128	19	229	20	8	M16
8	200	200	16	727 701 319	5.440	298	235	22	340	27	8	M20
8	200	225	16	727 701 320	5.621	298	238	22	340	27	8	M20

EPDM 48 44 07
FPM 49 44 07

Profile flange gasket metric

Model:

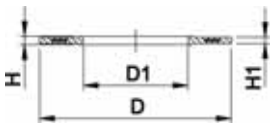

- For all metric GF Flange Adaptors
- Profile Gasket with steel insert (type G-ST-P/K)
- Hardness: 70° Shore **EPDM**, 75° Shore **FPM**
- **EPDM**: approved acc. to DVGW W 270, KTW recommendation
- Centering on the inner diameter of the screw crown
- material steel insert: carbon steel

di FA are the suitable inner diameters of flange adaptors



d [mm]	DN [mm]	PN	EPDM Code	FPM Code	kg	D [mm]	D1 [mm]	H [mm]	H1 [mm]	di FA [mm]
20	15	16	748 440 706	749 440 706	0.013	51	20	4	3	10 - 20
25	20	16	748 440 707	749 440 707	0.014	61	22	4	3	12 - 22
32	25	16	748 440 708	749 440 708	0.019	71	28	4	3	18 - 28
40	32	16	748 440 709	749 440 709	0.026	82	40	4	3	30 - 40
50	40	16	748 440 710	749 440 710	0.039	92	46	4	3	36 - 46
63	50	16	748 440 711	749 440 711	0.050	107	58	5	4	48 - 58

PROGEF Natural Hand-Operated and Actuated Valves

		Page
	Diaphragm Valves	338
	Diaphragm valves pneumatic	340

Diaphragm Valves

PROGEF Natural

Diaphragm valve type 515

With butt fusion spigots SDR11 metric

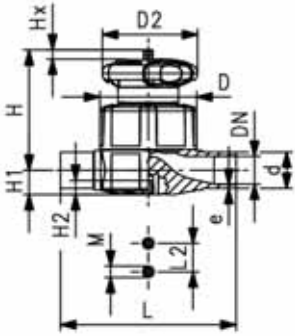

Model:

- Material: PP-R unpigmented
- Double flow rate compared to predecessor
- One housing nut replaces four screws
- Handwheel with built-in locking mechanism
- Overall length EN 558

Option:

- Individual configuration of the valve (see diagram)
- Self adjusting multifunctional module with integrated limit switches

d [mm]	DN [mm]	PN	kv-value ($\Delta p=1$ bar) [l/min]	EPDM Code	PTFE/EPDM Code	kg
20	15	10	125	168 515 112	168 515 132	0.308
25	20	10	271	168 515 113	168 515 133	0.393
32	25	10	481	168 515 114	168 515 134	0.969
40	32	10	759	168 515 115	168 515 135	1.125
50	40	10	1263	168 515 116	168 515 136	2.083
63	50	10	1728	168 515 117	168 515 137	2.630

d [mm]	D [mm]	D2 [mm]	L [mm]	L2 [mm]	H [mm]	H1 [mm]	H2 [mm]	M	Lift = Hx [mm]
20	65	65	124	25	73	14	12	M6	7
25	80	65	144	25	81	18	12	M6	10
32	88	87	155	25	107	22	12	M6	13
40	101	87	176	45	115	26	15	M8	15
50	117	135	193	45	148	32	15	M8	19
63	144	135	223	45	166	39	15	M8	25



PROGEF Natural Diaphragm valve type 519 With butt fusion spigots SDR11 metric

Model:

- Material: PP-R unpigmented
- Double flow rate compared to predecessor
- One housing nut replaces four screws
- Handwheel with built-in locking mechanism
- Smallest possible dead space

Option:

- Individual configuration of the valve (see diagram)
- Self adjusting multifunctional module with integrated limit switches

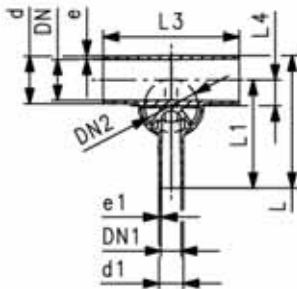
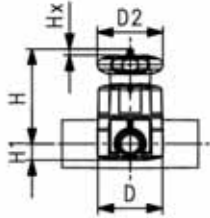

d [mm]	d1 [mm]	Valve Size d [mm]	DN [mm]	DN1 [mm]	DN2 [mm]	PN	kv-value ($\Delta p=1$ bar) [l/min]	EPDM Code	PTFE/EPDM Code	kg
20	20	20	15	15	15	10	57	168 519 101	168 519 301	0.321
25	20	25	20	15	20	10	89	168 519 103	168 519 303	0.397
25	25	25	20	20	20	10	118	168 519 104	168 519 304	0.399
32	20	25	25	15	20	10	80	168 519 107	168 519 307	0.424
32	25	25	25	20	20	10	105	168 519 108	168 519 308	0.426
32	32	32	25	25	25	10	231	168 519 109	168 519 309	0.980
40	20	32	32	15	25	10	85	168 519 112	168 519 312	1.008
50	20	25	40	15	20	10	86	168 519 118	168 519 318	0.485
50	25	32	40	20	25	10	160	168 519 119	168 519 319	1.054
50	32	32	40	25	25	10	206	168 519 120	168 519 320	1.056
63	20	25	50	15	20	10	84	168 519 125	168 519 325	0.524
63	25	32	50	20	25	10	150	168 519 126	168 519 326	1.097
63	32	32	50	25	25	10	184	168 519 127	168 519 327	1.100

d [mm]	D [mm]	D2 [mm]	L [mm]	L1 [mm]	L3 [mm]	L4 [mm]	H [mm]	Lift = Hx [mm]	e [mm]	e1 [mm]
20	65	65	117	96	162	12	75	7	1.9	1.9
25	80	65	133	108	162	16	80	10	2.3	1.9
25	80	65	133	108	162	16	80	10	2.3	2.3
32	80	65	142	120	162	19	84	10	2.9	1.9
32	80	65	142	120	162	19	84	10	2.9	2.3
32	88	87	145	120	160	19	107	13	2.9	2.9
40	88	87	149	128	180	23	115	13	3.7	1.9
50	80	65	160	134	180	27	97	10	4.6	1.9
50	88	87	160	134	180	28	120	13	4.6	2.3
50	88	87	160	134	180	28	120	13	4.6	2.9
63	80	65	177	144	180	33	104	10	5.8	1.9
63	88	87	177	144	180	35	127	13	5.8	2.3
63	88	87	177	144	180	35	127	13	5.8	2.9

Diaphragm valves pneumatic

PROGEF Natural

Diaphragm valve DIASTAR Six

FC (Fail safe to close)

With butt fusion spigots SDR11 metric

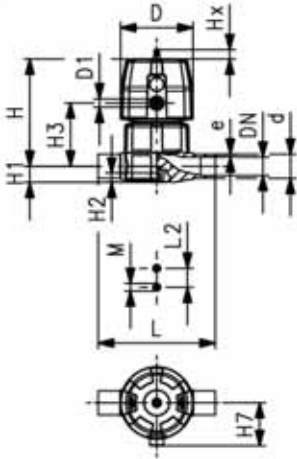

Model:

- Material: PP-R unpigmented
- Double flow rate compared to predecessor
- One housing nut replaces four screws
- Rotating air connection at 90° intervals

Option:

- Individual configuration of the valve (see diagram)

d [mm]	DN [mm]	PN	kv-value ($\Delta p=1$ bar) [l/min]	EPDM Code	kg
20	15	6	125	168 615 112	0.466
25	20	6	271	168 615 113	0.900
32	25	6	481	168 615 114	1.063
40	32	6	759	168 615 115	1.744
50	40	6	960	168 615 116	2.203
63	50	6	1181	168 615 117	2.979

d [mm]	D [mm]	D1_G [inch]	L [mm]	L2 [mm]	H [mm]	H1 [mm]	H2 [mm]	H3 [mm]	H7 [mm]	M	Lift = Hx [mm]	e [mm]
20	68	1/8	124	25	101	14	12	60	43	M6	7	1.9
25	96	1/8	144	25	132	18	12	73	57	M6	10	2.3
32	96	1/8	154	25	143	22	12	84	57	M6	13	2.9
40	120	1/8	174	45	173	26	15	99	69	M8	14	3.7
50	120	1/8	194	45	193	32	15	119	69	M8	16	4.6
63	120	1/8	224	45	205	39	15	132	69	M8	16	5.8

PROGEF Natural

Diaphragm valve DIASTAR Ten

FC (Fail safe to close)

With butt fusion spigots SDR11 metric

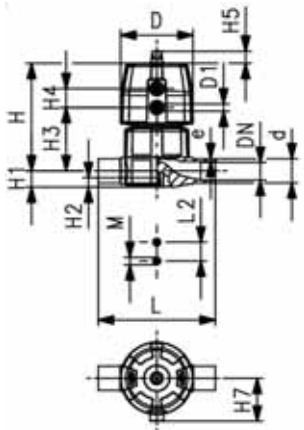

Model:

- Material: PP-R unpigmented
- Double flow rate compared to predecessor
- One housing nut replaces four screws
- Rotating air connection at 90° intervals

Option:

- Individual configuration of the valve (see diagram)
- Comprehensive range of accessories available

* PN: PTFE

Working Pressure: **one side**

d [mm]	DN [mm]	PN*	kv-value ($\Delta p=1$ bar) [l/min]	EPDM Code	PTFE Code	kg
20	15	10/6*	125	168 625 112	168 625 132	0.502
25	20	10/6*	271	168 625 113	168 625 133	0.987
32	25	10/6*	481	168 625 114	168 625 134	1.155
40	32	10/6*	759	168 625 115	168 625 135	1.914
50	40	10/6*	1263	168 625 116	168 625 136	3.371
63	50	10/5*	1728	168 625 117	168 625 137	3.928

table continued next page

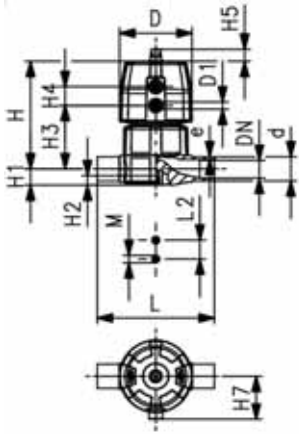

d	D	D1_G	L	L2	H	H1	H2	H3	H4	H5	H7	M	Lift = Hx	e
[mm]	[mm]	[inch]	[mm]	[mm]	[mm]	[mm]	[mm]	[mm]	[mm]	[mm]	[mm]		[mm]	[mm]
20	68	1/8	124	25	101	14	12	60	24	16	43	M6	7	1.9
25	96	1/8	144	25	132	18	12	73	25	16	57	M6	10	2.3
32	96	1/8	154	25	143	22	12	84	25	16	57	M6	13	2.9
40	120	1/4	174	45	173	26	15	99	26	26	69	M8	15	3.7
50	150	1/4	194	45	214	32	15	119	36	26	88	M8	19	4.6
63	150	1/4	224	45	226	39	15	132	36	26	88	M8	23	5.8



PROGEF Natural Diaphragm valve DIASTAR Ten FO (Fail safe to open) With butt fusion spigots SDR11 metric

Model:

- Material: PP-R unpigmented
- Double flow rate compared to predecessor
- One housing nut replaces four screws
- Rotating air connection at 90° intervals

Option:

- Individual configuration of the valve (see diagram)
- Comprehensive range of accessories available

* PN: PTFE

Working Pressure: **one side**

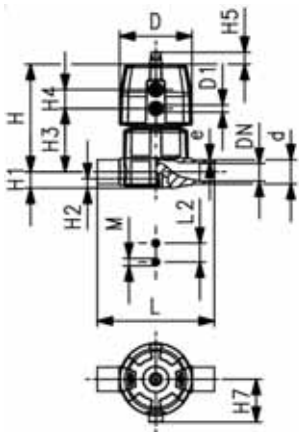

d	DN	PN*	kv-value	EPDM	kg
[mm]	[mm]	[bar]	($\Delta p=1$ bar)	Code	
			[l/min]		
20	15	10/6*	125	168 645 112	0.442
25	20	10/6*	271	168 645 113	0.801
32	25	10/6*	481	168 645 114	0.954
40	32	10/6*	759	168 645 115	1.534
50	40	10/6*	1263	168 645 116	3.251
63	50	10/5*	1728	168 645 117	3.810

d	D	D1_G	L	L2	H	H1	H2	H3	H4	H5	H7	M	Lift = Hx	e
[mm]	[mm]	[inch]	[mm]	[mm]	[mm]	[mm]	[mm]	[mm]	[mm]	[mm]	[mm]		[mm]	[mm]
20	68	1/8	124	25	101	14	12	60	24	16	43	M6	7	1.9
25	96	1/8	144	25	132	18	12	73	25	16	57	M6	10	2.3
32	96	1/8	154	25	143	22	12	84	25	16	57	M6	13	2.9
40	120	1/4	174	45	173	26	15	99	26	26	69	M8	15	3.7
50	150	1/4	194	45	214	32	15	119	36	26	88	M8	19	4.6
63	150	1/4	224	45	226	39	15	132	36	26	88	M8	23	5.8



PROGEF Natural

Diaphragm valve DIASTAR Ten

DA (Double acting)

With butt fusion spigots SDR11 metric

Model:

- Material: PP-R unpigmented
- Double flow rate compared to predecessor
- One housing nut replaces four screws
- Rotating air connection at 90° intervals

Option:

- Individual configuration of the valve (see diagram)
- Comprehensive range of accessories available

* PN: PTFE

Working Pressure: **one side**

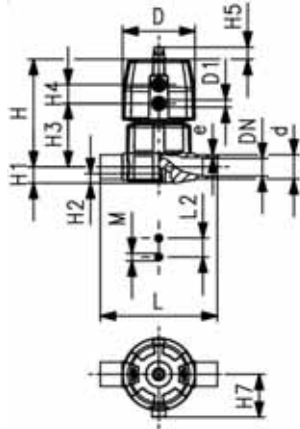

d [mm]	DN [mm]	PN* [bar]	kv-value ($\Delta p=1$ bar) [l/min]	EPDM Code	kg
20	15	10/6*	125	168 655 112	0.426
25	20	10/6*	271	168 655 113	0.765
32	25	10/6*	481	168 655 114	0.924
40	32	10/6*	759	168 655 115	1.474
50	40	10/6*	1263	168 655 116	2.501
63	50	10/5*	1728	168 655 117	3.060

d [mm]	D [mm]	D1_G [inch]	L [mm]	L2 [mm]	H [mm]	H1 [mm]	H2 [mm]	H3 [mm]	H4 [mm]	H5 [mm]	H7 [mm]	M	Lift = Hx [mm]	e [mm]
20	68	1/8	124	25	101	14	12	60	24	16	43	M6	7	1.9
25	96	1/8	144	25	132	18	12	73	25	16	57	M6	10	2.3
32	96	1/8	154	25	143	22	12	84	25	16	57	M6	13	2.9
40	120	1/8	174	45	173	26	15	99	26	26	69	M8	15	3.7
50	150	1/4	194	45	214	32	15	119	36	26	88	M8	19	4.6
63	150	1/4	224	45	226	39	15	132	36	26	88	M8	23	5.8



PROGEF Natural Diaphragm valve DIASTAR Ten FC (Fail safe to close) With butt fusion spigots SDR11 metric

Model:

- Material: PP-R unpigmented
- Double flow rate compared to predecessor
- One housing nut replaces four screws
- Rotating air connection at 90° intervals
- Smallest possible dead space

Option:

- Individual configuration of the valve (see diagram)
- Comprehensive range of accessories available

* PN: PTFE

Working Pressure: **one side**

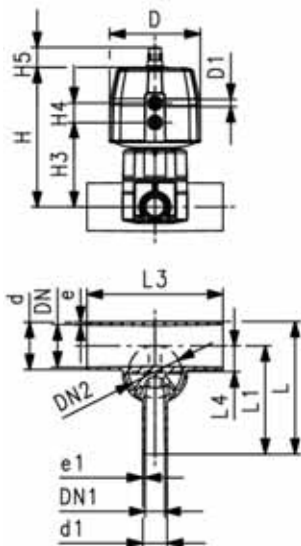

d [mm]	d1 [mm]	Valve Size d [mm]	DN [mm]	DN1 [mm]	DN2 [mm]	PN* [bar]	kv-value ($\Delta p=1$ bar) [l/min]	EPDM Code	PTFE/EPDM Code
20	20	20	15	15	15	10/6*	57	168 629 101	168 629 301
25	20	25	20	15	20	10/6*	89	168 629 103	168 629 303
25	25	25	20	20	20	10/6*	118	168 629 104	168 629 304
32	20	25	25	15	20	10/6*	80	168 629 107	168 629 307
32	25	25	25	20	20	10/6*	105	168 629 108	168 629 308
32	32	32	25	25	25	10/6*	231	168 629 109	168 629 309
40	20	32	32	15	25	10/6*	85	168 629 112	168 629 312
50	20	25	40	15	20	10/6*	86	168 629 118	168 629 318
50	25	32	40	20	25	10/6*	160	168 629 119	168 629 319
50	32	32	40	25	25	10/6*	206	168 629 120	168 629 320
63	20	25	50	15	20	10/6*	84	168 629 125	168 629 325
63	25	32	50	20	25	10/6*	150	168 629 126	168 629 326
63	32	32	50	25	25	10/6*	184	168 629 127	168 629 327

d [mm]	D [mm]	D1 [inch]	L [mm]	L1 [mm]	L3 [mm]	L4 [mm]	H [mm]	H3 [mm]	H4 [mm]	H5 [mm]	Lift = Hx [mm]	e [mm]	e1 [mm]
20	68	1/8	117	96	162	12	104	71	25	16	7	1.9	1.9
25	96	1/8	133	108	162	16	131	72	25	16	10	2.3	1.9
25	96	1/8	133	108	162	16	131	72	25	16	10	2.3	2.3
32	96	1/8	142	120	162	19	135	76	25	16	10	2.9	1.9
32	96	1/8	142	120	162	19	135	76	25	16	10	2.9	2.3
32	96	1/8	145	120	160	19	143	93	25	16	13	2.9	2.9
40	96	1/8	149	128	180	23	151	101	25	16	13	3.7	1.9
50	96	1/8	160	134	180	27	148	90	25	16	10	4.6	1.9
50	96	1/8	160	134	180	28	156	106	25	16	13	4.6	2.3
50	96	1/8	160	134	180	28	156	106	25	16	13	4.6	2.9
63	96	1/8	177	144	180	33	155	96	25	16	10	5.8	1.9
63	96	1/8	177	144	180	35	163	113	25	16	13	5.8	2.3
63	96	1/8	177	144	180	35	163	113	25	16	13	5.8	2.9

PROGEF® Plus General Information



- Pipes
- Butt Fusion System

PROGEF Plus – System Specification





Material	Beta PP-H 100 (Beta Polypropylene Homopolymer) d20 - d225	State-of-the-art PP (Polypropylene) d250 - d315
Colour	RAL 7032 pebble grey	RAL 7032 pebble grey
Density	~0.90g/cm ³ (ISO 1183/ASTM D792)	~0.90g/cm ³ (ISO 1183 / ASTM D792)
Surface tension	31 mJ/m ²	24 mJ/m ²
Linear expansion coefficient	0.16 mm/mK (DIN 53752)	0.16-0.18 mm/mK (DIN 53752)
E-modulus	1300N/mm ² (ISO 527/ASTM D790)	900N/mm ² (ISO 527/ASTM D790)
Thermal conductivity	0.23 W/mK (EN 12664)	0.23 W/mK (EN 12664)
Surface resistivity	> 10 ¹⁶ Ω (IEC 60093)	> 10 ¹⁶ Ω (IEC 60093)
Dimension	d20 – d315 in accordance to EN ISO 15494	
Pressure Rating	Pipes/Fittings/Diaphragm and ball valves: d20 – d225 SDR11, PN10, c=2.0 d50 – d225 SDR17.6, PN6, c=2.0 Butterfly valves: d63–d225, PN10	Pipes/Fittings: d250 – d315 SDR11, PN10, c=2.0 d250 – d315 SDR17.6, PN6, c=2.0
Temperature Rating	From 0°C to 80°C (32°F – 176°F)	
Production	Fittings/valves: injection moulded Pipes: extruded Treatment: Every component is specially cleaned according to a process defined by +GF+. Pipes and fittings are silicon-, oil- and dustfree. Additional specifications for valves. Products especially suitable for the paint and microelectronics industry.	
Surface Finish	Inner surface Ra ≤ 1.0 µm (39 µin) for components d20 – d110 Inner surface Ra ≤ 1.5 µm (59 µin) for components d125 – d315	
Marking	All components are embossed with a permanent identification during the production process to ensure full traceability: Lot No Material Dimension Pressure Rating	
Testing and Inspection (EN ISO 15494)	Visual inspection Surface finish Dimension tolerance Pressure testing Full product range passed the Initial Type Test (ITT)	
Approvals/Conformance ⁽¹⁾	FDA CFR 21 177.1520 USP 25 class VI (physiological non-toxic)	
Welding Technology	IR Plus, infrared fusion (DVS 2207-6): d20 – d225 Butt fusion (DVS 2207-11): d20 – d315	
Documentation ⁽²⁾	EN 10204 2.2 / EN 10204 3.1	
Packing	Pipes: Capped and double bagged in specified bag Fittings/valves: Each component double bagged in specified bag	
Labeling	Brand Name Product Description Code Number Material Dimension CE-labeling ⁽³⁾ Approvals	
Main Applications	Due to the special treatment, PROGEF Plus piping systems are suitable for economical delivery of ultrapure water in semiconductor and TFT/FPD applications and ensure high quality in the paint industry. Highly resistant to impact, abrasion and many chemicals.	

⁽¹⁾ For thermoplastic material only

⁽²⁾ On request

⁽³⁾ From 2008 on

PROGEF Plus Pipes, Fittings, Unions, Flanges and Flange Adap- tors

		Page
	Pipes	348
	Fittings for Butt Fusion	349
	Unions for Butt Fusion	353
	Flange Adaptors, Flanges and Gaskets for Butt Fusion	354
	Unions for Socket Fusion	358

Pipes

PROGEF Plus S5/SDR11 (PN10)

Model:

- Material: PP-H
- DIN 8077 / 8078 - DIBT Z-40.23-4
- Closed with caps and double bagged (LDPE-foil)
- Colour: RAL 7032 pebble grey
- Length: Lengths of 5 m

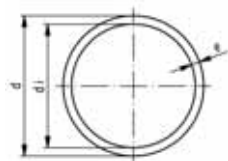

d [mm]	PN	Code	kg/m	e [mm]	di [mm]
20	10	167 481 711	0.107	1.9	16.2
25	10	167 481 712	0.164	2.3	20.4
32	10	167 481 713	0.261	2.9	24.2
40	10	167 481 714	0.412	2.9	32.6
50	10	167 481 715	0.638	4.6	40.8
63	10	167 481 716	1.010	5.8	51.4
75	10	167 481 717	1.410	6.8	61.4
90	10	167 481 718	2.030	8.2	73.6
110	10	167 481 719	3.010	10.0	90.0
125	10	167 481 720	3.910	11.4	102.2
140	10	167 481 721	4.870	12.7	114.6
160	10	167 481 722	6.380	14.6	130.8
180	10	167 481 723	8.070	16.4	147.2
200	10	167 481 724	9.950	18.2	163.6
225	10	167 481 725	12.600	20.5	184.0
250	10	167 481 726	15.500	22.7	184.6
280	10	167 481 727	19.400	25.4	229.2
315	10	167 481 728	24.600	28.6	257.0

Fittings for Butt Fusion

PROGEF Plus bend 90° S5/SDR11

Model:

- Material: PP-H
- Conventional butt-welding according to DVS 2207 part 11
- IR = Infrared-(IR Plus®) compatible. Choose fusion parameters: PP-H
- Cleaned and double bagged



d [mm]	FM	Code	L [mm]	L1 [mm]	R [mm]	e [mm]
20	IR	727 018 681	38	23	15	1,9
25	IR	727 018 682	42	23	19	2,3
32	IR	727 018 683	46	22	24	2,9
40	IR	727 018 684	51	21	30	3,7
50	IR	727 018 685	58	21	37	4,6
63	IR	727 018 686	66	21	45	5,8
75	IR	727 018 662	100	20	90	6,8
90	IR	727 018 663	100	20	90	8,2
110	IR	727 018 664	141	25	130	10,0
125	IR	727 018 475	140	15	125	11,4
140	IR	727 018 476	155	15	140	12,7
160	IR	727 018 477	175	15	160	14,6
180	IR	727 018 478	195	15	180	16,4
200	IR	727 018 479	215	15	200	18,2
225	IR	727 018 480	245	20	225	20,5
250	--	727 018 450	256	49	232	22,7
280	--	727 018 451	286	44	262	25,4
315	--	727 018 452	321	51	297	28,6

PROGEF Plus elbow 90° S5/SDR11

Model:

- Material: PP-H
- Conventional butt-welding according to DVS 2207 part 11
- IR = Infrared-(IR Plus®) compatible. Choose fusion parameters: PP-H
- Cleaned and double bagged

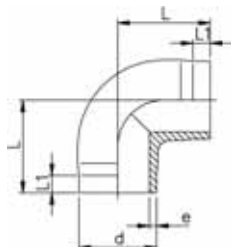

d [mm]	FM	Code	L [mm]	L1 [mm]	e [mm]
20	IR	727 108 581	38	25	1,9
25	IR	727 108 582	42	26	2,3
32	IR	727 108 583	46	27	2,9
40	IR	727 108 584	51	22	3,7
50	IR	727 108 585	58	23	4,6
63	IR	727 108 586	66	21	5,8

PROGEF Plus elbow 45° S5/SDR11

Model:

- Material: PP-H
- Conventional butt-welding according to DVS 2207 part 11
- IR = Infrared-(IR Plus®) compatible. Choose fusion parameters: PP-H
- Cleaned and double bagged
- Long version for d250, d280 and d315

¹ Material: PP-R

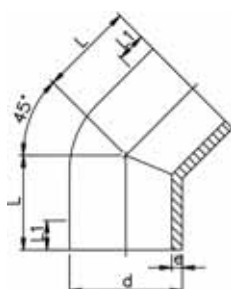

d [mm]	FM	Code	L [mm]	L1 [mm]	e [mm]
20	IR	727 158 581	32	24	1,9
25	IR	727 158 582	34	25	2,3
32	IR	727 158 583	36	25	2,9
40	IR	727 158 584	39	25	3,7
50	IR	727 158 585	42	26	4,6
63	IR	727 158 586	47	29	5,8
75	IR	727 158 587	49	29	6,8
90	IR	727 158 588	57	34	8,2

table continued next page

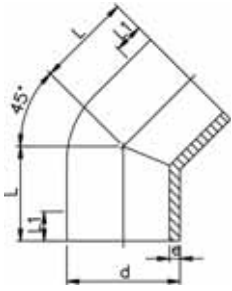

d [mm]	FM	Code	L [mm]	L1 [mm]	e [mm]
110	IR	727 158 589	70	43	10,0
125	IR	727 158 590	79	48	11,4
140	IR	727 158 591	88	55	12,7
160	IR	727 158 592	100	60	14,6
200	IR	727 158 594	124	75	18,2
225	IR	727 158 595	140	85	20,5
250	--	727 158 596	225	133	22,7
280	--	727 158 597	235	143	25,4
315	--	727 158 598	255	154	28,6

PROGEF Plus tee 90° equal S5/SDR11

Model:

- Material: PP-H
- Conventional butt-welding according to DVS 2207 part 11
- IR = Infrared-(IR Plus®) compatible. Choose fusion parameters: PP-H
- Cleaned and double bagged

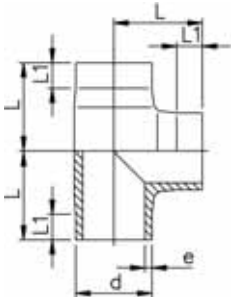

d [mm]	FM	Code	L [mm]	L1 [mm]	e [mm]
20	IR	727 208 581	38	24	1,9
25	IR	727 208 582	42	26	2,3
32	IR	727 208 583	46	26	2,9
40	IR	727 208 584	51	23	3,7
50	IR	727 208 585	58	22	4,6
63	IR	727 208 586	66	20	5,8
75	IR	727 208 587	75	20	6,8
90	IR	727 208 588	90	20	8,2
110	IR	727 208 589	110	20	10,0
125	IR	727 208 590	125	25	11,4
140	IR	727 208 591	140	28	12,7
160	IR	727 208 592	160	28	14,6
180	IR	727 208 593	195	73	16,4
200	IR	727 208 594	200	35	18,2
225	IR	727 208 595	220	35	20,5
250	--	727 208 596	275	86	22,7
280	--	727 208 597	310	105	25,4
315	--	727 208 598	350	111	28,6

Tee 90° reducing, S5/SDR11

Model:

- Material: PP-H
- Conventional butt-welding according to DVS 2207 part 11
- IR = Infrared-(IR Plus®) compatible. Choose fusion parameters: PP-H
- Cleaned and double bagged

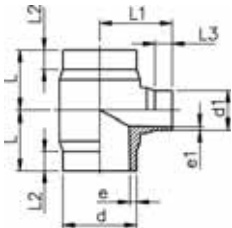

d [mm]	d1 [mm]	FM	Code	L [mm]	L1 [mm]	L2 [mm]	L3 [mm]	e [mm]	e1 [mm]
63	32	IR	727 208 251	65	70	25	25	5,8	2,9
63	50	IR	727 208 252	65	70	25	25	5,8	4,6
75	32	IR	727 208 253	70	75	25	25	6,8	2,9
75	50	IR	727 208 254	70	75	25	25	6,8	4,6
75	63	IR	727 208 255	70	75	25	25	6,8	5,8
90	50	IR	727 208 257	80	85	25	25	8,2	4,6
90	63	IR	727 208 258	80	85	25	25	8,2	5,8
90	75	IR	727 208 259	80	85	25	25	8,2	6,8
110	32	IR	727 208 260	90	95	30	25	10,0	2,9
110	50	IR	727 208 261	90	95	30	25	10,0	4,6
110	63	IR	727 208 262	90	95	30	25	10,0	5,8
110	75	IR	727 208 263	90	95	30	25	10,0	6,8
110	90	IR	727 208 264	90	95	30	25	10,0	8,2
160	63	IR	727 208 271	142	135	50	30	14,6	5,8
160	75	IR	727 208 272	142	135	50	30	14,6	6,8
160	90	IR	727 208 273	142	135	50	30	14,6	8,2
160	110	IR	727 208 274	142	135	50	30	14,6	10,0

table continued next page

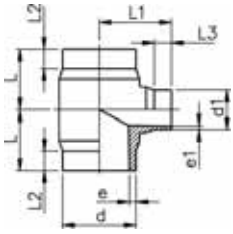

d [mm]	d1 [mm]	FM	Code	L [mm]	L1 [mm]	L2 [mm]	L3 [mm]	e [mm]	e1 [mm]
225	90	IR	727 208 288	155	165	40	30	20,5	8,2
225	110	IR	727 208 289	155	165	40	30	20,5	10,0
225	160	IR	727 208 291	155	165	40	30	20,5	14,6



Reducers, S5/SDR11

Model:

- Material: PP-H
- Conventional butt-welding according to DVS 2207 part 11
- IR = Infrared-(IR Plus®) compatible. Choose fusion parameters: PP-H
- Cleaned and double bagged

¹ Material: PP-R

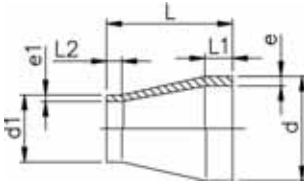

d [mm]	d1 [mm]	FM	Code	L [mm]	L1 [mm]	L2 [mm]	e [mm]	e1 [mm]
25	20	IR	727 908 637	50	20	20	2,3	1,9
32	20	IR	727 908 642	50	20	20	2,9	1,9
32	25	IR	727 908 641	50	20	20	2,9	2,3
40	20	IR	727 908 648	58	20	23	3,7	1,9
40	25	IR	727 908 647	55	20	20	3,7	2,3
40	32	IR	727 908 646	55	20	20	3,7	2,9
50	25	IR	727 908 654	60	20	20	4,6	2,3
50	32	IR	727 908 653	60	20	20	4,6	2,9
50	40	IR	727 908 652	60	20	20	4,6	3,7
63	32	IR	727 908 660	65	20	20	5,8	2,9
63	40	IR	727 908 659	65	20	20	5,8	3,7
63	50	IR	727 908 658	65	20	20	5,8	4,6
75	40	IR	727 908 666	68	20	20	6,8	3,7
75	50	IR	727 908 665	65	20	20	6,8	4,6
75	63	IR	727 908 664	65	20	20	6,8	5,8
90	63	IR	727 908 671	75	22	19	8,2	5,8
90	75	IR	727 908 670	75	21	19	8,2	6,8
110	75	IR	727 908 677	90	28	18	10,0	6,8
110	90	IR	727 908 676	90	28	20	10,0	8,2
125	110	IR	727 908 680	100	31	30	11,4	10,0
140	110	IR	727 908 685	110	33	29	12,7	10,0
140	125	IR	727 908 684	110	34	30	12,7	11,4
160	110	IR	727 908 690	120	38	27	14,6	10,0
160	140	IR	727 908 688	120	40	35	14,6	12,7
180	90	IR	727 908 691	157	45	22	16,4	8,2
180	110	IR	727 908 955	157	45	28	16,4	10,0
180	125	IR	727 908 698	136	45	32	16,4	11,4
180	140	IR	727 908 699	136	45	35	16,4	12,7
180	160	IR	727 908 952	136	45	40	16,4	14,6
200	160	IR	727 908 692	145	50	40	18,2	14,6
200	180	IR	727 908 693	151	50	45	18,2	16,4
225	110	IR	727 908 695	160	55	35	20,5	10,0
225	160	IR	727 908 696	160	55	40	20,5	14,6
225	180	IR	727 908 694	171	55	45	20,5	16,4
225	200	IR	727 908 697	160	55	50	20,5	18,2
250	160	--	727 908 700	194	60	40	22,7	14,6
250	225	--	727 908 701	182	60	55	22,7	20,5
¹ 280	225	--	727 908 702	200	85	80	25,4	20,5
¹ 280	250	--	727 908 703	200	85	90	25,4	22,7
¹ 315	225	--	727 908 704	230	95	88	28,6	20,5
¹ 315	250	--	727 908 705	230	95	95	28,6	22,7
¹ 315	280	--	727 908 706	230	95	107	28,6	25,4

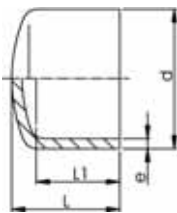

End Caps, S5/SDR11

Model:

- Material: PP-H
- Conventional butt-welding according to DVS 2207 part 11
- IR = Infrared-(IR Plus®) compatible. Choose fusion parameters: PP-H
- Cleaned and double bagged

d [mm]	FM	Code	L [mm]	L1 [mm]	e [mm]
20	IR	727 968 981	45	35	1,9
25	IR	727 968 982	52	40	2,3
32	IR	727 968 983	58	44	2,9
40	IR	727 968 984	67	50	3,7
50	IR	727 968 985	75	55	4,6
63	IR	727 968 986	85	62	5,8
75	IR	727 968 987	95	63	6,8
90	IR	727 968 988	110	79	8,2
110	IR	727 968 989	127	88	10,0
125	IR	727 968 990	138	102	11,4
140	IR	727 968 991	144	106	12,7
160	IR	727 968 992	154	109	14,6
180	IR	727 968 993	191	141	16,4
200	IR	727 968 994	181	127	18,2
225	IR	727 968 995	211	141	20,5

Unions for Butt Fusion

EPDM 27 51 86
FPM 27 52 86

PROGEF Plus union S5/SDR11

Model:

- Material: PP-H
- With butt fusion ends
- IR = Infrared-(IR Plus®) compatible. Choose fusion parameters: PP-H
- Cleaned and double bagged

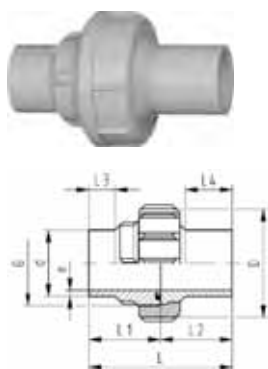

d [mm]	PN	D [mm]	FM	EPDM Code	FPM Code
20	10	48	IR	727 518 606	727 528 606
25	10	58	IR	727 518 607	727 528 607
32	10	65	IR	727 518 608	727 528 608
40	10	79	IR	727 518 609	727 528 609
50	10	91	IR	727 518 610	727 528 610
63	10	111	IR	727 518 611	727 528 611
75	10	135	IR	727 518 612	727 528 612
90	10	135	IR	727 518 613	727 528 613
110	10	158	IR	727 518 614	727 528 614

d [mm]	G [inch]	L [mm]	L1 [mm]	L2 [mm]	L3 [mm]	e [mm]	O-Ring EPDM	O-Ring FPM	Size
20		107	54	53	26	1,9	748.413.006	749.413.006	20,22 x 3,53
25	1 1/4	113	57	56	26	2,3	748.413.007	749.413.007	28,17 x 3,53
32	1 1/2	119	60	59	26	2,9	748.413.008	749.413.008	32,93 x 3,53
40	2	126	63	63	26	3,7	748.413.009	749.413.009	40,65 x 5,34
50	2 1/4	131	66	66	26	4,6	748.413.010	749.413.010	47,00 x 5,34
63	2 3/4	137	69	68	26	5,8	748.413.011	749.413.011	59,69 x 5,34
75	S107,5x3,6	132	66	66	24	6,8	748.413.013	749.413.013	69,22 x 5,34
90	S107,5x3,6	131	66	66	24	8,2	748.413.014	749.413.014	81,92 x 5,34
110	S127,5x3,6	131	66	66	25	10,0	748.413.015	749.413.015	101,00 x 5,34

Flange Adaptors, Flanges and Gaskets for Butt Fusion

PROGEF Plus flange adaptor S5/SDR11 Combined jointing Face: flat and serrated

Model:

- Material: PP-H
- Conventional butt-welding according to DVS 2207 part 11
- IR = Infrared-(IR Plus®) compatible. Choose fusion parameters: PP-H
- Suitable for flange connections to metric (**from d110 also to ANSI/ASME B16.5**)
- Up to d315, suitable for butterfly valve type 567/568
- Up to d280, suitable for butterfly valve type 037/038/039
- Gasket: Profile flange gasket EPDM No. 48 44 17, FPM No. 49 44 17
- Cleaned and double bagged

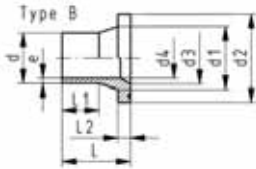
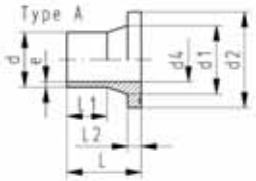

d [mm]	DN [mm]	FM	Code	d1 [mm]	d2 [mm]	d3 [mm]	d4 [mm]	L [mm]	L1 [mm]	L2 [mm]	e [mm]	Type
20	15	IR	727 798 731	26	45		16	50	29	7	1.9	A
25	20	IR	727 798 732	32	58		20	52	27	9	2.3	A
32	25	IR	727 798 733	40	68		26	54	28	10	2.9	A
40	32	IR	727 798 734	49	78		32	56	25	11	3.7	A
50	40	IR	727 798 735	60	88		40	62	32	12	4.6	A
63	50	IR	727 798 736	75	102		51	68	38	14	5.8	A
75	65	IR	727 798 737	89	122	66	61	80	43	16	6.8	B
90	80	IR	727 798 738	105	138	78	73	80	41	17	8.2	B
110	100	IR	727 798 739	125	158	100	90	80	40	18	10.0	B
125	100	IR	727 798 740	132	158	114	102	82	35	25	11.4	B
140	125	IR	727 798 741	155	188	127	114	89	39	25	12.7	B
160	150	IR	727 798 742	175	212	151	130	92	45	25	14.6	B
180	150	IR	727 798 743	180	212	154	147	80	45	30	16.4	B
200	200	IR	727 798 744	232	268	203	163	100	30	32	18.2	B
225	200	IR	727 798 745	235	268	210	184	100	35	32	20.5	B
250	250		727 798 746	285	320	250	204	100	25	35	22.7	B
280	250		727 798 747	291	320	265	229	100	35	35	25.4	B
315	300		727 798 748	335	370	300	257	100	25	35	28.6	B

27 70 14
27 70 15

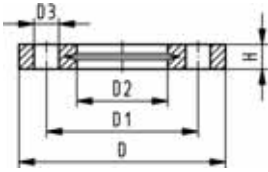

Backing flange PP-V For butt fusion systems Inch ANSI

Model:

- Modern full-plastic flange PP-GF (30 % glass-fibre reinforced)
- With V-groove which applies force evenly on collar
- With integrated bolt-fixing as an assembly aid
- UV-resistant. Applicable for outside applications
- Connecting dimension: ANSI/ASME B 16.5 class 150, ASTM D 4024, BS 1560, BS EN 1759
- **Bolt circle class 150**

¹⁾ Suitable for socket- and butt fusion systems (no pictograph on flange)

AL: number of holes

* Combined version, metric-ANSI

Inch	DN [mm]	d [mm]	PN	Code	D [mm]	D1 [mm]	D2 [mm]	D3 [mm]	H [mm]	AL	SC
1/2	15	20	16	727 701 406	95	60.0	28	16	16	4	M12
3/4	20	25	16	727 701 407	105	70.0	34	16	17	4	M12
1	25	32	16	727 701 408	115	79.0	42	16	18	4	M12
1 1/4	32	40	16	727 701 409	140	89.0	51	16	20	4	M16
1 1/2	40	50	16	727 701 410	150	98.0	62	16	22	4	M16
2	50	63	16	727 701 411	165	121.0	78	19	24	4	M16
2 1/2	65	75	16	727 701 412	185	140.0	92	19	26	4	M16
3	80	90	16	727 701 513	200	152.0	108	19	27	4	M16
4	100	110	16	727 701 514	229	190.0	128	19	28	8	M16
10	250	250	16	727 701 521	406	362.0	288	26	38	12	M20
10	250	280	16	727 701 522	406	362.0	294	26	38	12	M20
12	300	315	16	727 701 523	483	432.0	338	26	42	12	M20

27 70 04
27 70 05

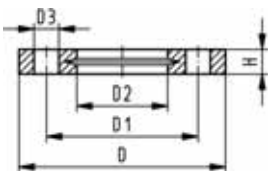

Backing flange PP-V For butt fusion systems metric

Model:

- Modern full-plastic flange PP-GF (30 % glass-fibre reinforced)
- With V-groove which applies force evenly on collar
- With integrated bolt retainers as an assembly aid
- UV-resistant. Applicable for outside applications
- Connecting dimension: ISO 7005, EN 1092, BS 4504, DIN 2501
- **Bolt circle PN 10**

* Combined version, metric-ANSI

AL: number of holes

¹⁾ Suitable for socket- and butt fusion systems (no pictograph on flange)

d [mm]	DN [mm]	PN	Code	D [mm]	D1 [mm]	D2 [mm]	D3 [mm]	H [mm]	AL	SC
¹⁾ 20	15	16	727 700 406	95	65.0	28	14	16	4	M12
¹⁾ 25	20	16	727 700 407	105	75.0	34	14	17	4	M12
¹⁾ 32	25	16	727 700 408	115	85.0	42	14	18	4	M12
¹⁾ 40	32	16	727 700 409	140	100.0	51	18	20	4	M16
¹⁾ 50	40	16	727 700 410	150	110.0	62	18	22	4	M16
¹⁾ 63	50	16	727 700 411	165	125.0	78	18	24	4	M16
¹⁾ 75	65	16	727 700 412	185	145.0	92	18	26	4	M16
90	80	16	727 700 513	200	160.0	108	18	27	8	M16
110	100	16	727 700 514	220	180.0	128	18	28	8	M16
125	100	16	727 700 515	220	180.0	135	18	28	8	M16
140	125	16	727 700 516	250	210.0	158	18	30	8	M16
180	150	16	727 700 518	285	240.0	188	22	32	8	M20
250	250	16	727 700 521	395	350.0	288	22	38	12	M20
280	250	16	727 700 522	395	350.0	294	22	38	12	M20
315	300	16	727 700 523	445	400.0	338	22	42	12	M20

27 70 12

Backing flange PP-Steel For butt fusion systems Inch ANSI

Model:

- Material: PP (30 % glass-fibre reinforced) with steel ring
- UV-resistant. Applicable for outside applications
- Connecting dimension: ANSI/ASME B 16.5 class 150, ASTM D 4024, BS 1560, BS EN 1759
- **Bolt circle class 150**

AL: number of holes

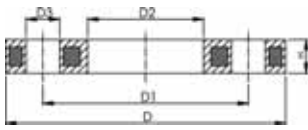

d [inch]	DN [mm]	d [mm]	PN	Code	D1 [mm]	D2 [mm]	D3 [mm]	D [mm]	H [mm]	AL	SC
½	15	20	16	727 701 206	60	28	16	95	12	4	M12
¾	20	25	16	727 701 207	70	34	16	105	12	4	M12
1	25	32	16	727 701 208	79	42	16	115	16	4	M12
1 ¼	32	40	16	727 701 209	89	51	16	140	16	4	M16
1 ½	40	50	16	727 701 210	98	62	16	150	18	4	M16
2	50	63	16	727 701 211	121	78	19	165	18	4	M16
2 ½	65	75	16	727 701 212	140	92	19	185	18	4	M16
3	80	90	16	727 701 313	152	108	19	200	20	4	M16
4	100	110	16	727 701 314	190	128	19	229	20	8	M16
8	200	200	16	727 701 319	298	235	22	340	27	8	M20
8	200	225	16	727 701 320	298	238	22	340	27	8	M20

27 70 02
27 70 03

Backing flange PP-Steel For butt fusion systems metric

Model:

- Material: PP (30 % glass-fibre reinforced) with steel ring
- UV-resistant. Applicable for outside applications
- Connecting dimension: ISO 7005, EN 1092, BS 4504, DIN 2501
- **Bolt circle PN 10**

AL: number of holes

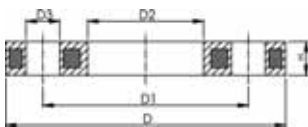

d [mm]	DN [mm]	PN	Code	D [mm]	D1 [mm]	D2 [mm]	D3 [mm]	H [mm]	AL	SC
20	15	16	727 700 206	95	65	28	14	12	4	M12
25	20	16	727 700 207	105	75	34	14	12	4	M12
32	25	16	727 700 208	115	85	42	14	16	4	M12
40	32	16	727 700 209	140	100	51	18	16	4	M16
50	40	16	727 700 210	150	110	62	18	20	4	M16
63	50	16	727 700 211	165	125	78	18	20	4	M16
75	65	16	727 700 212	185	145	92	18	20	4	M16
90	80	16	727 700 313	200	160	108	18	20	8	M16
110	100	16	727 700 314	220	180	128	18	20	8	M16
125	100	16	727 700 315	220	180	135	18	20	8	M16
140	125	16	727 700 316	250	210	158	18	24	8	M16
180	150	16	727 700 318	285	240	188	22	24	8	M20
200	200	16	727 700 319	340	295	235	22	27	8	M20
225	200	16	727 700 320	340	295	238	22	27	8	M20
250	250	16	727 700 321	395	350	288	22	30	12	M20
280	250	16	727 700 322	395	350	294	22	30	12	M20
315	300	16	727 700 323	445	400	338	22	34	12	M20



PROGEF Plus outlet flange adaptor S5/SDR11 Combined jointing Face: flat and serrated

Model:

- Material: PP-R unpigmented
- Conventional butt-welding according to DVS 2207 part 11
- To wafer check valves Type 369
- Cleaned and double bagged

Attention:

- In conjunction with outlet flange adaptors, **flange rings for socket systems** must be used.

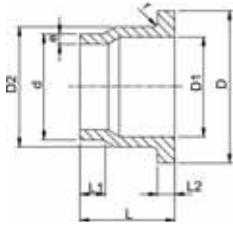

d [mm]	DN [mm]	Code	D [mm]	D1 [mm]	D2 [mm]	L [mm]	L1 [mm]	L2 [mm]	e [mm]	r [mm]
40	32	727 808 134	80	37	50	64	30	11	3,7	3
50	40	727 808 135	90	43	61	67	30	12	4,6	3
63	50	727 808 136	105	54	76	74	30	14	5,8	4
75	65	727 808 137	125	70	90	78	30	16	6,8	4
90	80	727 808 138	140	82	108	87	35	17	8,2	4
110	100	727 808 139	160	105	131	102	41	18	10,0	4
140	125	727 808 141	190	130	165	124	47	25	12,7	4
160	150	727 808 142	215	158	188	149	52	25	14,6	4
225	200	727 808 145	270	206	248	180	55	32	20,5	4
280	250	727 808 147	325	259	308	240	63	35	25,4	4
315	300	727 808 148	375	308	346	272	66	35	28,6	4

EPDM 48 44 17
FPM 49 44 17

Profile flange gasket silicone free

Model:

- Silicone free / paint-compatible
- For all metric GF Flange Adaptors
- Profile Gasket with steel insert (type G-ST-P/K)
- Hardness: 70° Shore **EPDM**, 75° Shore **FPM**

di FA are the suitable inner diameters of flange adaptors

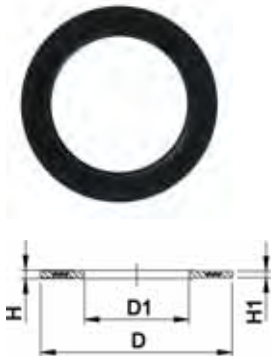

d [mm]	DN [mm]	PN	EPDM Code	FPM Code	D [mm]	D1 [mm]	H [mm]	H1 [mm]	di FA [mm]
20	15	16	748 441 706	749 441 706	51	20	4	3	10 - 20
25	20	16	748 441 707	749 441 707	61	22	4	3	12 - 22
32	25	16	748 441 708	749 441 708	71	28	4	3	18 - 28
40	32	16	748 441 709	749 441 709	82	40	4	3	30 - 40
50	40	16	748 441 710	749 441 710	92	46	4	3	36 - 46
63	50	16	748 441 711	749 441 711	107	58	5	4	48 - 58
75	65	16	748 441 712	749 441 712	127	69	5	4	59 - 69
90	80	16	748 441 713	749 441 713	142	84	5	4	73 - 84
110	100	16	748 441 714	749 441 714	162	104	6	5	94 - 104
125	100	16	748 441 715	749 441 715	162	123	6	5	113 - 123
140	125	16	748 441 716	749 441 716	192	137	6	5	127 - 137
160 / 180	150	16	748 441 717	749 441 717	218	160	8	6	150 - 160
200	200	16	748 441 719	749 441 719	273	203	8	6	192 - 203
225	200	16	748 441 720	749 441 720	273	220	8	6	207 - 207
250	250	16	748 441 721	749 441 721	328	252	8	6	238 - 250
280	250	16	748 441 722	749 441 722	328	274	8	6	264 - 274
315	300	16	748 441 723	749 441 723	378	306	8	6	296 - 296

Unions for Socket Fusion

EPDM 27 51 02
FPM 27 52 02

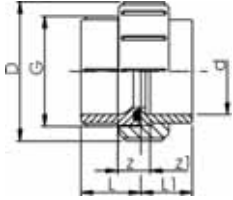

PROGEF Plus union





Model:

- Material: PP-H
- Fusion socket metric
- D75-110 with new thread geometry, now rated PN10 up to d110
- Jointing face: with O-Ring
- Cleaned and double bagged

d [mm]	PN	EPDM Code	FPM Code
16	10	727 510 255	727 520 255
20	10	727 510 256	727 520 256
25	10	727 510 257	727 520 257
32	10	727 510 258	727 520 258
40	10	727 510 259	727 520 259
50	10	727 510 260	727 520 260
63	10	727 510 261	727 520 261
75	10	727 510 272	727 520 272
90	10	727 510 273	727 520 273
110	10	727 510 274	727 520 274

d [mm]	D [mm]	G [inch]	L [mm]	L1 [mm]	z [mm]	z1 [mm]	O-Ring EPDM	O-Ring FPM	Size
16	35	3/4	24	18	5	11	748.413.005	749.413.005	15,54 x 2,62
20	48	1	26	19	5	12	748.413.006	749.413.006	20,22 x 3,53
25	58	1 1/4	28	21	5	12	748.413.007	749.413.007	28,17 x 3,53
32	65	1 1/2	30	23	5	12	748.413.008	749.413.008	32,93 x 3,53
40	79	2	34	25	5	14	748.413.009	749.413.009	40,65 x 5,54
50	91	2 1/4	39	28	5	16	748.413.010	749.413.010	47,00 x 5,34
63	111	2 3/4	47	32	5	20	748.413.011	749.413.011	59,69 x 5,34
75	135	S107,5x3,6	51	36	5	20	748.413.014	749.413.014	81,92 x 5,34
90	158	S127,5x3,6	55	42	7	20	748.413.015	749.413.015	101,00 x 5,34
110	188	S152,5x3,6	54	49	7	12	748.413.016	748.413.016	120,00 x 6,99

PROGEF Plus Hand-Operated and Actuated Valves

		Page
	Ball Valve	360
	Ball valves	364
	Diaphragm valves silicon free	366
	Butterfly valves	375
	Cone check valves	379

Ball Valve

Ball Valve Type 546, PP-H SF with mounting inserts With fusion sockets metric

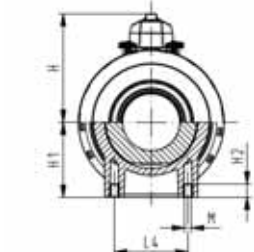
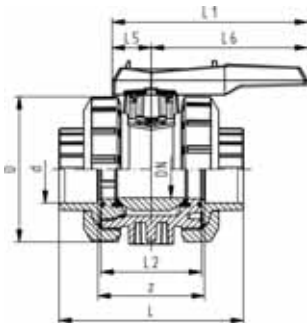
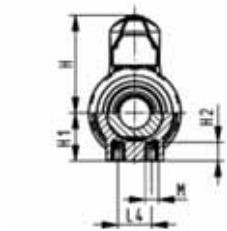
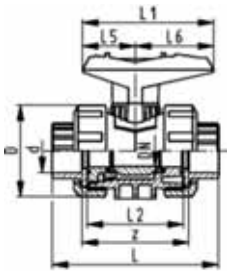

Model:

- Material: PP-H / silicone free cleaned
- For easy installation and removal
- z-dimension, valve end and union nut are **not compatible** with type 346 (DN10/15-50) resp. type 370 (DN65-100)
- Integrated stainless steel mounting inserts
- Double bagged
- Ball seals PVDF

Option:

- Individual configuration of the valve (see diagram)
- Multifunctional module with integrated limit switches

d [mm]	DN [mm]	PN	kv-value ($\Delta p=1$ bar) [l/min]	EPDM Code	FPM Code	kg
16	10	10	71	167 546 601	167 546 611	0.115
20	15	10	185	167 546 602	167 546 612	0.115
25	20	10	350	167 546 603	167 546 613	0.180
32	25	10	700	167 546 604	167 546 614	0.255
40	32	10	1000	167 546 605	167 546 615	0.440
50	40	10	1600	167 546 606	167 546 616	0.610
63	50	10	3100	167 546 607	167 546 617	1.145
75	65	10	5000	167 546 608	167 546 618	3.700
90	80	10	7000	167 546 609	167 546 619	5.500
110	100	10	11000	167 546 610	167 546 620	8.700

d [mm]	D [mm]	H [mm]	H1 [mm]	H2 [mm]	L [mm]	L1 [mm]	L2 [mm]	L4 [mm]	L5 [mm]	L6 [mm]	M	z [mm]
16	50	57	27	12	93	77	56	25	32	45	M6	67
20	50	57	27	12	95	77	56	25	32	45	M6	66
25	58	67	30	12	108	97	65	25	39	58	M6	77
32	68	73	36	12	118	97	71	25	39	58	M6	83
40	84	90	44	15	137	128	85	45	54	74	M8	99
50	97	97	51	15	147	128	89	45	54	74	M8	105
63	124	116	64	15	168	152	101	45	66	87	M8	117
75	166	149	85	15	233	270	136	70	64	206	M8	167
90	200	161	105	15	254	270	141	70	64	206	M8	180
110	238	178	123	22	301	320	164	120	64	256	M12	215

Ball Valve Type 546, PP-H SF with mounting inserts With socket fusion spigots metric



DN10/15 - 50

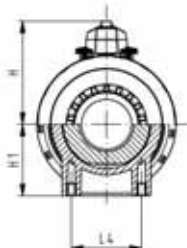
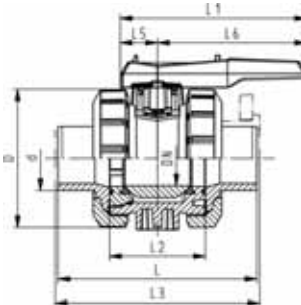
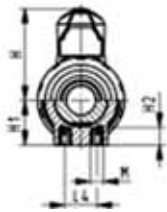
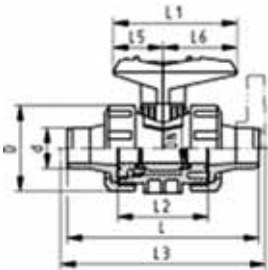

Model:

- Material: PP-H / silicone free cleaned
- For easy installation and removal
- z-dimension, valve end and union nut are **not compatible** with type 346 (DN10/15-50) resp. type 370 (DN65-100)
- Integrated stainless steel mounting inserts
- Double bagged
- Ball seals PVDF

Option:

- Individual configuration of the valve (see diagram)
- Multifunctional module with integrated limit switches

d [mm]	DN [mm]	PN	kv-value ($\Delta p=1$ bar) [l/min]	EPDM Code	FPM Code	kg
16	10	10	71	167 546 621	167 546 631	0.120
20	15	10	185	167 546 622	167 546 632	0.120
25	20	10	350	167 546 623	167 546 633	0.180
32	25	10	700	167 546 624	167 546 634	0.260
40	32	10	1000	167 546 625	167 546 635	0.450
50	40	10	1600	167 546 626	167 546 636	0.640
63	50	10	3100	167 546 627	167 546 637	1.210
75	65	10	5000	167 546 628	167 546 638	3.800
90	80	10	7000	167 546 629	167 546 639	5.600
110	100	10	11000	167 546 630	167 546 640	8.800

d [mm]	D [mm]	H [mm]	H1 [mm]	H2 [mm]	L [mm]	L1 [mm]	L2 [mm]	L3 [mm]	L4 [mm]	L5 [mm]	L6 [mm]	M
16	50	57	27	12	110	77	56		25	32	45	M6
20	50	57	27	12	120	77	56	130	25	32	45	M6
25	58	67	30	12	139	97	65	150	25	39	58	M6
32	68	73	36	12	150	97	71	160	25	39	58	M6
40	84	90	44	15	170	128	85	180	45	54	74	M8
50	97	97	51	15	190	128	89	200	45	54	74	M8
63	124	116	64	15	220	152	101	230	45	66	87	M8
75	166	149	85	15	280	270	136	290	70	64	206	M8
90	200	161	105	15	296	270	141	310	70	64	206	M8
110	238	178	123	22	336	320	164	350	120	64	256	M12



DN10/15 - 50

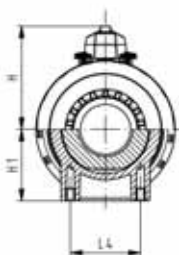
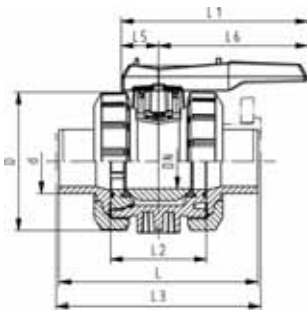
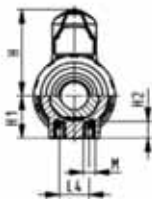
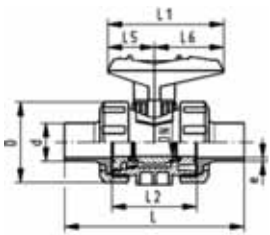

Ball Valve Type 546, PP-H SF with mounting inserts With butt fusion spigots IR-Plus SDR11 metric

Model:

- Material: PP-H / silicone free cleaned
- For easy installation and removal
- z-dimension, valve end and union nut are **not compatible** with type 346 (DN10/15-50) resp. type 370 (DN65-100)
- Integrated stainless steel mounting inserts
- Double bagged
- Ball seals PVDF

Option:

- Individual configuration of the valve (see diagram)
- Multifunctional module with integrated limit switches

d [mm]	DN [mm]	PN	kv-value ($\Delta p=1$ bar) [l/min]	EPDM Code	FPM Code	kg
20	15	10	185	167 546 662	167 546 672	0.120
25	20	10	350	167 546 663	167 546 673	0.180
32	25	10	700	167 546 664	167 546 674	0.255
40	32	10	1000	167 546 665	167 546 675	0.440
50	40	10	1600	167 546 666	167 546 676	0.620
63	50	10	3100	167 546 667	167 546 677	1.200
75	65	10	5000	167 546 668	167 546 678	2.612
90	80	10	7000	167 546 669	167 546 679	5.500
110	100	10	11000	167 546 670	167 546 680	8.700

d [mm]	D [mm]	H [mm]	H1 [mm]	H2 [mm]	L [mm]	L1 [mm]	L2 [mm]	L4 [mm]	L5 [mm]	L6 [mm]	M	e [mm]
20	50	57	27	12	130	77	56	25	32	45	M6	1.9
25	58	67	30	12	143	97	65	25	39	58	M6	2.3
32	68	73	36	12	150	97	71	25	39	58	M6	3.0
40	84	90	44	15	171	128	85	45	54	74	M8	3.7
50	97	97	51	15	191	128	89	45	54	74	M8	4.6
63	124	116	64	15	220	152	101	45	66	87	M8	5.8
75	166	149	85	15	266	270	136	70	64	206	M8	8.2
90	200	161	105	15	264	270	141	70	64	206	M8	9.9
110	238	178	123	22	301	320	164	120	64	256	M12	12.0



Ball Valve Type 546, PP-H SF with mounting inserts With backing flanges PP-st metric

Model:

- Material: PP-H / silicone free cleaned
- For easy installation and removal
- z-dimension, valve end and union nut are **not compatible** with type 346 (DN10/15-50) resp. type 370 (DN65-100)
- Integrated stainless steel mounting inserts
- Double bagged
- Ball seals PVDF
- Overall length according to EN 558
- Connecting dimension: ISO 7005, EN 1092, BS 4504, DIN 2501

Option:

- Individual configuration of the valve (see diagram)
- Multifunctional module with integrated limit switches

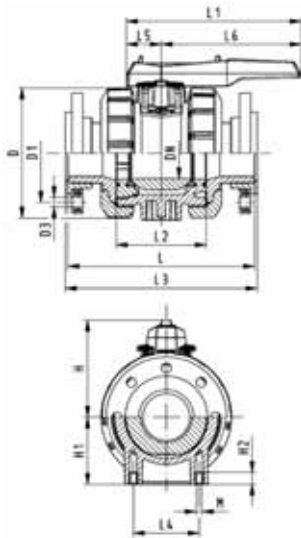

d [mm]	DN [mm]	PN	kv-value ($\Delta p=1$ bar) [l/min]	EPDM Code	FPM Code	kg
75	65	10	5000	167 546 828	167 546 838	4.300
90	80	10	7000	167 546 829	167 546 839	6.400
110	100	10	11000	167 546 830	167 546 840	10.000

d [mm]	D [mm]	D1 [mm]	D3 [mm]	L [mm]	L1 [mm]	L2 [mm]	L3 [mm]	L4 [mm]	L5 [mm]	L6 [mm]	H [mm]	H1 [mm]	M
75	166	145	18	280	270	136	290	70	64	206	149	85	8
90	200	160	18	296	270	141	310	70	64	206	161	105	8
110	238	180	18	336	320	164	350	120	64	256	178	123	12



Ball Valve Type 546, PP-H SF with mounting inserts With backing flanges PP-st Inch ANSI

Model:

- Material: PP-H / silicone free cleaned
- For easy installation and removal
- z-dimension, valve end and union nut are **not compatible** with type 346 (DN10/15-50) resp. type 370 (DN65-100)
- Integrated stainless steel mounting inserts
- Double bagged
- Ball seals PTFE
- Overall length according to EN 558
- Connecting dimension ANSI/ASME B 16.5 / ASTM D 4024

Option:

- Individual configuration of the valve (see diagram)
- Multifunctional module with integrated limit switches

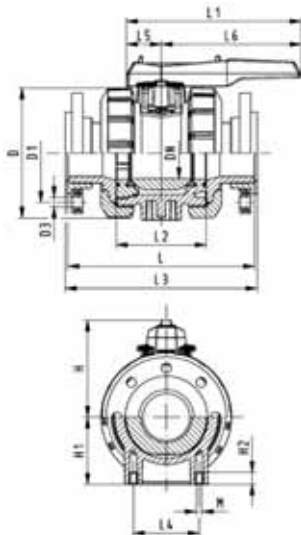

d [mm]	DN [mm]	PN	kv-value ($\Delta p=1$ bar) [l/min]	EPDM Code	FPM Code	kg
75	65	10	5000	167 546 888	167 546 898	4.300
90	80	10	7000	167 546 889	167 546 899	6.400
110	100	10	11000	167 546 890	167 546 900	10.000

d [mm]	D [mm]	D1 [mm]	D3 [mm]	L [mm]	L1 [mm]	L2 [mm]	L3 [mm]	L4 [mm]	L5 [mm]	L6 [mm]	H [mm]	H1 [mm]	M
75	166	140	19	280	270	136	290	70	64	206	149	85	8
90	200	152	19	296	270	141	310	70	64	206	161	105	8
110	238	191	19	336	320	164	350	120	64	256	178	123	12

Ball valves

PROGEF Plus oil free Ball valve type 546 With mounting inserts With fusion sockets metric



DN10/15 - 50

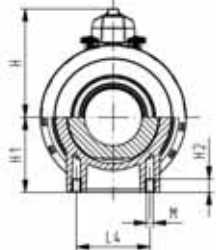
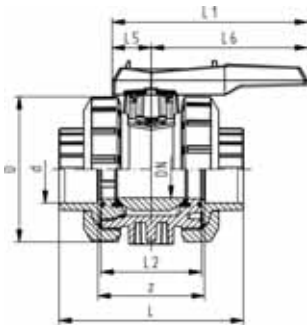
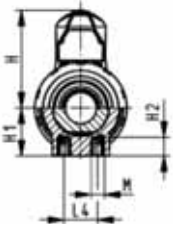
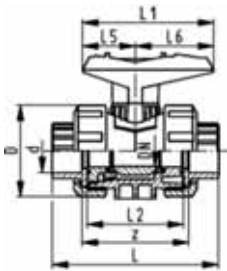

Model:

- Material: PP-H / oil free cleaned
- For easy installation and removal
- z-dimension, valve end and union nut are **not compatible** with type 346 (DN10/15-50) resp. type 370 (DN65-100)
- Ball seals PTFE
- Integrated stainless steel mounting inserts

Option:

- Individual configuration of the valve (see diagram)
- Multifunctional module with integrated limit switches

d [mm]	DN [mm]	PN	kv-value ($\Delta p=1$ bar) [l/min]	EPDM Code	FPM Code	kg
20	15	10	185	167 546 902	167 546 912	0.115
25	20	10	350	167 546 903	167 546 913	0.184
32	25	10	700	167 546 904	167 546 914	0.260
40	32	10	1000	167 546 905	167 546 915	0.440
50	40	10	1600	167 546 906	167 546 916	0.620
63	50	10	3100	167 546 907	167 546 917	1.145
75	65	10	5000	167 546 908	167 546 918	3.700
90	80	10	7000	167 546 909	167 546 919	5.500
110	100	10	11000	167 546 910	167 546 920	8.700

d [mm]	D [mm]	H [mm]	H1 [mm]	H2 [mm]	L [mm]	L1 [mm]	L2 [mm]	L4 [mm]	L5 [mm]	L6 [mm]	M	z [mm]
20	50	57	27	12	95	77	56	25	32	45	M6	66
25	58	67	30	12	109	97	65	25	39	58	M6	77
32	68	73	36	12	119	97	71	25	39	58	M6	83
40	84	90	44	15	135	128	85	45	54	74	M8	99
50	97	97	51	15	147	128	89	45	54	74	M8	105
63	124	116	64	15	168	152	101	45	66	87	M8	117
75	166	149	85	15	233	270	136	70	64	206	M8	167
90	200	161	105	15	254	270	141	70	64	206	M8	180
110	238	178	123	22	301	320	164	120	64	256	M12	215



DN10/15 - 50



PROGEF Plus oil free Ball valve type 546 With mounting inserts With butt fusion spigots IR-Plus SDR11 metric

Model:

- Material: PP-H / oil free cleaned
- For easy installation and removal
- z-dimension, valve end and union nut are **not compatible** with type 346 (DN10/15-50) resp. type 370 (DN65-100)
- Ball seals PTFE
- Integrated stainless steel mounting inserts

Option:

- Individual configuration of the valve (see diagram)
- Multifunctional module with integrated limit switches

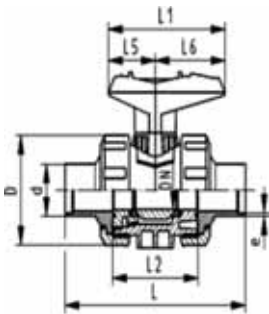

d [mm]	DN [mm]	PN	kv-value ($\Delta p=1$ bar) [l/min]	EPDM Code	kg
20	15	10	185	167 546 482	0.120
25	20	10	350	167 546 483	0.183
32	25	10	700	167 546 484	0.259
40	32	10	1000	167 546 485	0.452
50	40	10	1600	167 546 486	0.620
63	50	10	3100	167 546 487	1.200
75	65	10	5000	167 546 488	3.800
90	80	10	7000	167 546 489	5.500
110	100	10	11000	167 546 490	8.700

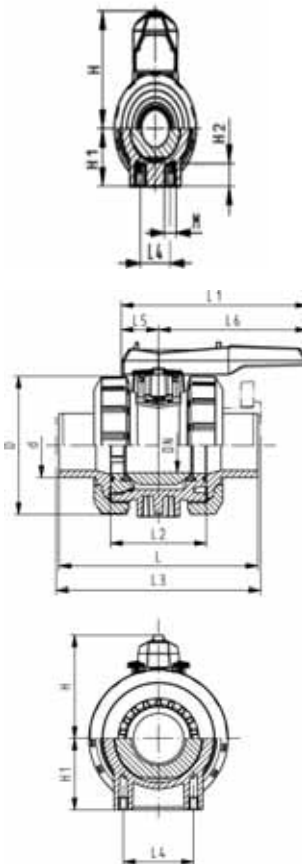

d [mm]	D [mm]	H [mm]	H1 [mm]	H2 [mm]	L [mm]	L1 [mm]	L2 [mm]	L4 [mm]	L5 [mm]	L6 [mm]	M	e [mm]
20	50	57	27	12	130	77	56	25	32	45	M6	1,9
25	58	67	30	12	143	97	65	25	39	58	M6	2,3
32	68	73	36	12	150	97	71	25	39	58	M6	3
40	84	90	44	15	171	128	85	45	54	74	M8	3,7
50	97	97	51	15	191	128	89	45	54	74	M8	4,6
63	124	116	64	15	220	152	101	45	66	87	M8	5,8
75	166	149	85	15	266	270	136	70	64	206	M8	8,2
90	200	161	105	15	264	270	141	70	64	206	M8	9,9
110	238	178	123	22	301	320	164	120	64	256	M12	12

Diaphragm valves silicon free

PROGEF Plus silicone free Diaphragm valve type 514 With fusion sockets metric

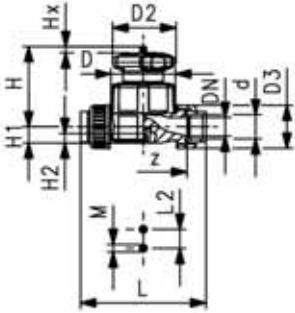

Model:

- Material: PP-H / silicone free cleaned
- Double flow rate compared to predecessor
- One housing nut replaces four screws
- Handwheel with built-in locking mechanism
- For easy installation and removal
- Short overall length

Option:

- Individual configuration of the valve (see diagram)
- Self adjusting multifunctional module with integrated limit switches

d [mm]	DN [mm]	PN	kv-value ($\Delta p=1$ bar) [l/min]	EPDM Code	PTFE/EPDM Code	kg
20	15	10	125	167 514 022	167 514 072	0.371
25	20	10	271	167 514 023	167 514 073	0.499
32	25	10	481	167 514 024	167 514 074	1.101
40	32	10	759	167 514 025	167 514 075	1.297
50	40	10	1263	167 514 026	167 514 076	1.376
63	50	10	1728	167 514 027	167 514 077	3.058

d [mm]	D [mm]	D2 [mm]	D3 [mm]	L [mm]	L2 [mm]	H [mm]	H1 [mm]	H2 [mm]	M	z [mm]	Lift = Hx [mm]
20	65	65	43	128	25	73	14	12	M6	100	7
25	80	65	51	150	25	81	18	12	M6	118	10
32	88	87	58	162	25	107	22	12	M6	126	13
40	101	87	72	184	45	115	26	15	M8	144	15
50	117	135	83	210	45	148	32	15	M8	164	19
63	144	135	100	248	45	166	39	15	M8	194	25

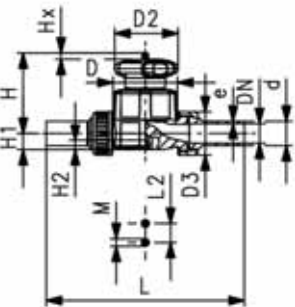

PROGEF Plus silicone free Diaphragm valve type 514 With butt fusion spigots SDR11 metric

Model:

- Material: PP-H / silicone free cleaned
- Double flow rate compared to predecessor
- One housing nut replaces four screws
- Handwheel with built-in locking mechanism
- For easy installation and removal
- Short overall length

Option:

- Individual configuration of the valve (see diagram)
- Self adjusting multifunctional module with integrated limit switches

d [mm]	DN [mm]	PN	kv-value ($\Delta p=1$ bar) [l/min]	EPDM Code	PTFE/EPDM Code	kg
20	15	10	125	167 514 122	167 514 172	0.274
25	20	10	271	167 514 123	167 514 173	0.404
32	25	10	481	167 514 124	167 514 174	0.652
40	32	10	759	167 514 125	167 514 175	0.853
50	40	10	1263	167 514 126	167 514 176	1.453
63	50	10	1728	167 514 127	167 514 177	3.072

table continued next page

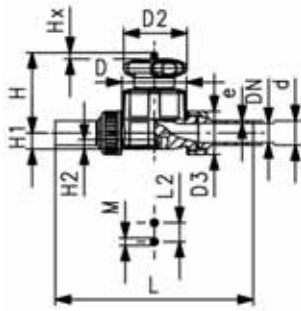

d [mm]	D [mm]	D2 [mm]	D3 [mm]	L [mm]	L2 [mm]	H [mm]	H1 [mm]	H2 [mm]	M	Lift = Hx [mm]	e [mm]
20	65	65	43	196	25	73	14	12	M6	7	1.9
25	80	65	51	221	25	81	18	12	M6	10	2.3
32	88	87	58	234	25	107	22	12	M6	13	2.9
40	101	87	72	260	45	115	26	15	M8	15	3.7
50	117	135	83	284	45	148	32	15	M8	19	4.6
63	144	135	100	321	45	166	39	15	M8	25	5.8



PROGEF Plus silicone free Diaphragm valve type 515 With socket fusion spigots metric

Model:

- Material: PP-H / silicone free cleaned
- Double flow rate compared to predecessor
- One housing nut replaces four screws
- Handwheel with built-in locking mechanism
- Overall length EN 558

Option:

- Individual configuration of the valve (see diagram)
- Self adjusting multifunctional module with integrated limit switches

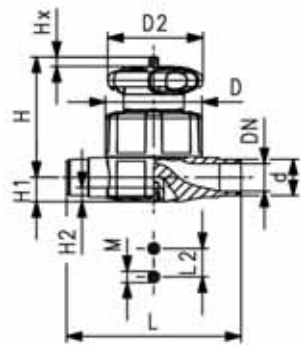

d [mm]	DN [mm]	PN	kv-value ($\Delta p=1$ bar) [l/min]	EPDM Code	PTFE/EPDM Code	kg
20	15	10	125	167 515 022	167 515 072	0.308
25	20	10	271	167 515 023	167 515 073	0.396
32	25	10	481	167 515 024	167 515 074	0.970
40	32	10	759	167 515 025	167 515 075	1.128
50	40	10	1263	167 515 026	167 515 076	2.087
63	50	10	1728	167 515 027	167 515 077	2.632

d [mm]	D [mm]	D2 [mm]	L [mm]	L2 [mm]	H [mm]	H1 [mm]	H2 [mm]	M	Lift = Hx [mm]	e [mm]
20	65	65	124	25	73	14	12	M6	7	1.9
25	80	65	144	25	81	18	12	M6	10	2.3
32	88	87	154	25	107	22	12	M6	13	2.9
40	101	87	174	45	115	26	15	M8	15	3.7
50	117	135	194	45	148	32	15	M8	19	4.6
63	144	135	223	45	166	39	15	M8	25	5.8



PROGEF Plus silicone free Diaphragm valve type 515 With butt fusion spigots SDR11 metric

Model:

- Material: PP-H / silicone free cleaned
- Double flow rate compared to predecessor
- One housing nut replaces four screws
- Handwheel with built-in locking mechanism
- Overall length EN 558

Option:

- Individual configuration of the valve (see diagram)
- Self adjusting multifunctional module with integrated limit switches

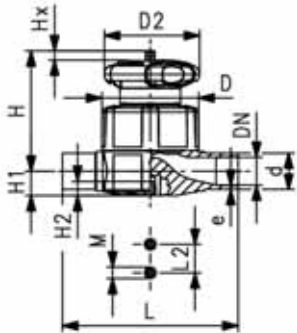

d [mm]	DN [mm]	PN	kv-value ($\Delta p=1$ bar) [l/min]	EPDM Code	PTFE/EPDM Code	kg
20	15	10	125	167 515 122	167 515 172	0.307
25	20	10	271	167 515 123	167 515 173	0.392
32	25	10	481	167 515 124	167 515 174	0.968
40	32	10	759	167 515 125	167 515 175	0.655
50	40	10	1263	167 515 126	167 515 176	2.082
63	50	10	1728	167 515 127	167 515 177	2.629

d [mm]	D [mm]	D2 [mm]	L [mm]	L2 [mm]	H [mm]	H1 [mm]	H2 [mm]	M	Lift = Hx [mm]	e [mm]
20	65	65	124	25	73	14	12	M6	7	1.9
25	80	65	144	25	81	18	12	M6	10	2.3
32	88	87	155	25	107	22	12	M6	13	2.9
40	101	87	176	45	115	26	15	M8	15	3.7
50	117	135	193	45	148	32	15	M8	19	4.6
63	144	135	223	45	166	39	15	M8	25	5.8



PROGEF Plus silicone free Diaphragm valve type 517 With backing flanges PP-V metric/BS

Model:

- Material: PP-H / silicone free cleaned
- Double flow rate compared to predecessor
- One housing nut replaces four screws
- Handwheel with built-in locking mechanism
- Overall length EN 558
- Connecting dimension: ISO 7005 PN 10, EN 1092 PN 10, DIN 2501 PN 10, BS 4504 PN 10
- Flat sealing faces/serrated

Option:

- Individual configuration of the valve (see diagram)
- Self adjusting multifunctional module with integrated limit switches

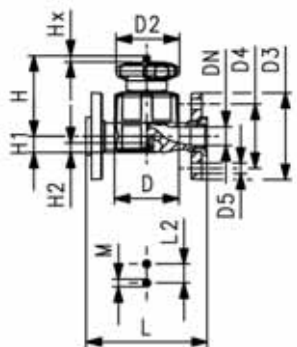

d [mm]	DN [mm]	PN	kv-value ($\Delta p=1$ bar) [l/min]	EPDM Code	PTFE/EPDM Code	kg
20	15	10	125	167 517 122	167 517 172	0.412
25	20	10	271	167 517 123	167 517 173	0.640
32	25	10	481	167 517 124	167 517 174	1.316
40	32	10	759	167 517 125	167 517 175	1.660
50	40	10	1263	167 517 126	167 517 176	2.601
63	50	10	1728	167 517 127	167 517 177	3.572

d [mm]	D [mm]	D2 [mm]	D3 [mm]	D4 [mm]	D5 [mm]	L [mm]	L2 [mm]	H [mm]	H1 [mm]	H2 [mm]	M	Lift = Hx [mm]
20	65	65	95	65	14	130	25	73	14	12	M6	7
25	80	65	105	75	14	150	25	81	18	12	M6	10
32	88	87	115	85	14	160	25	107	22	12	M6	13

table continued next page

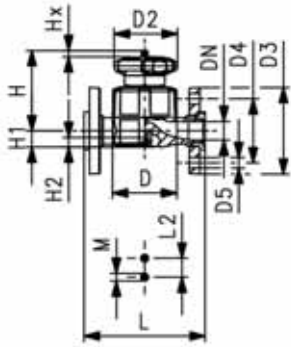

d [mm]	D [mm]	D2 [mm]	D3 [mm]	D4 [mm]	D5 [mm]	L [mm]	L2 [mm]	H [mm]	H1 [mm]	H2 [mm]	M	Lift = Hx [mm]
40	101	87	140	100	18	180	45	115	26	15	M8	15
50	117	135	150	110	18	200	45	148	32	15	M8	19
63	144	135	165	125	18	230	45	166	39	15	M8	25



PROGEF Plus oil free Diaphragm valve type 517 With fixed flanges PP-H JIS

Model:

- Material: PP-H / oil free cleaned
- Double flow rate compared to predecessor
- One housing nut replaces four screws
- Handwheel with built-in locking mechanism
- Connecting dimension: JIS B2238/39 10K
- Flat sealing faces/serrated

Option:

- Individual configuration of the valve (see diagram)
- Self adjusting multifunctional module with integrated limit switches

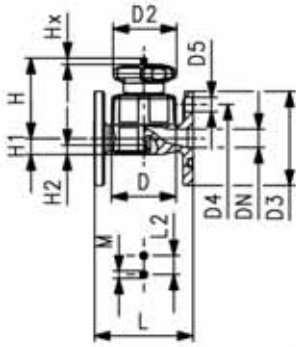

Inch	DN [mm]	PN	kv-value ($\Delta p=1$ bar) [l/min]	EPDM Code	PTFE/EPDM Code	kg
1/2	15	10	125	167 517 922	167 517 972	0.434
3/4	20	10	271	167 517 923	167 517 973	0.514
1	25	10	481	167 517 924	167 517 974	1.168
1 1/4	32	10	759	167 517 925	167 517 975	1.462
1 1/2	40	10	1263	167 517 926	167 517 976	2.449
2	50	10	1728	167 517 927	167 517 977	3.082

Inch	D [mm]	D2 [mm]	D3 [mm]	D4 [mm]	D5 [mm]	L [mm]	L2 [mm]	H [mm]	H1 [mm]	H2 [mm]	M	Lift = Hx [mm]
1/2	65	65	95	70	15	110	25	73	14	12	M6	7
3/4	80	65	100	75	15	120	25	81	18	12	M6	10
1	88	87	125	90	19	130	25	107	22	12	M6	13
1 1/4	101	87	135	100	19	180	45	115	26	15	M8	15
1 1/2	117	135	140	105	19	180	45	148	32	15	M8	19
2	144	135	155	120	19	210	45	166	39	15	M8	25



PROGEF Plus oil free Diaphragm valve DIASTAR Six FC (Fail safe to close) With fixed flanges PP-H JIS

Model:

- Material: PP-H / oil free cleaned
- Double flow rate compared to predecessor
- One housing nut replaces four screws
- Rotating air connection at 90° intervals
- Flat sealing faces/serrated
- Connecting dimension: JIS B2238/39 10K

Option:

- Individual configuration of the valve (see diagram)

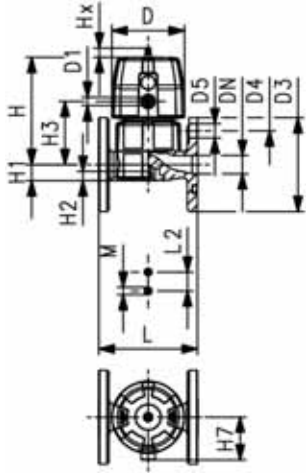

Inch	DN [mm]	PN	kv-value ($\Delta p=1$ bar) [l/min]	EPDM Code	kg
½	15	6	125	167 617 922	0.593
¾	20	6	271	167 617 923	1.023
1	25	6	481	167 617 924	1.263
1 ¼	32	6	759	167 617 925	2.082
1 ½	40	6	960	167 617 926	2.570
2	50	6	1181	167 617 927	3.432

Inch	D [mm]	D1_G [inch]	D3 [mm]	D4 [mm]	D5 [mm]	L [mm]	L2 [mm]	H [mm]	H1 [mm]	H2 [mm]	H3 [mm]	H7 [mm]	M	Lift = Hx [mm]
½	68	¾	95	70	15	110	25	101	14	12	60	43	M6	7
¾	96	¾	100	75	15	120	25	132	18	12	73	57	M6	10
1	96	¾	125	90	19	130	25	143	22	12	84	69	M6	13
1 ¼	120	¾	135	100	19	180	45	173	26	15	99	69	M8	14
1 ½	120	¾	140	105	19	180	45	193	32	15	119	69	M8	16
2	120	¾	155	120	19	210	45	205	39	15	132	69	M8	16



PROGEF Plus oil free Diaphragm valve DIASTAR Ten FC (Fail safe to close) With fixed flanges PP-H JIS

Model:

- Material: PP-H / oil free cleaned
- Double flow rate compared to predecessor
- One housing nut replaces four screws
- Rotating air connection at 90° intervals
- Connecting dimension: JIS B2238/39 10K
- Flat sealing faces/serrated

Option:

- Individual configuration of the valve (see diagram)
- Comprehensive range of accessories available

* PN: PTFE

Working Pressure: **one side**

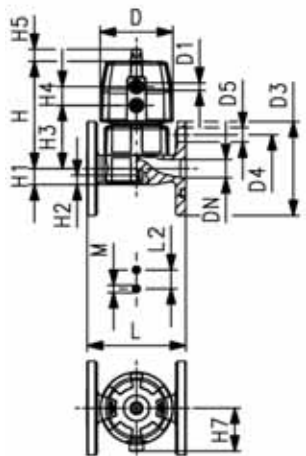

Inch	DN [mm]	PN* [bar]	kv-value ($\Delta p=1$ bar) [l/min]	EPDM Code	PTFE/EPDM Code	kg
½	15	10/10*	125	167 627 922	167 627 972	0.628
¾	20	10/10*	271	167 627 923	167 627 973	1.108
1	25	10/10*	481	167 627 924	167 627 974	1.354
1 ¼	32	10/10*	759	167 627 925	167 627 975	2.251
1 ½	40	10/10*	1263	167 627 926	167 627 976	3.737
2	50	10/6*	1728	167 627 927	167 627 977	4.380

table continued next page

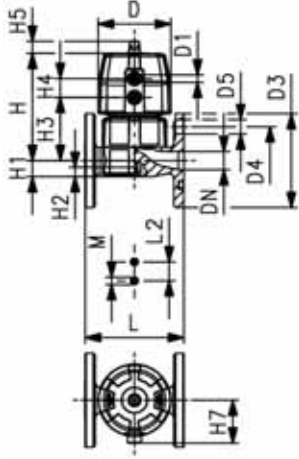

Inch	D [mm]	D1_G [inch]	D3 [mm]	D4 [mm]	D5 [mm]	L [mm]	L2 [mm]	H [mm]	H1 [mm]	H2 [mm]	H3 [mm]	H4 [mm]	H5 [mm]	H7 [mm]	M
1/2	68	1/8	95	70	15	110	25	101	14	12	60	24	16	43	M6
3/4	96	1/8	100	75	15	120	25	132	18	12	73	25	16	57	M6
1	96	1/8	125	90	19	130	25	143	22	12	84	25	16	69	M6
1 1/4	120	1/8	135	100	19	180	45	173	26	15	99	26	26	69	M8
1 1/2	150	1/4	140	105	19	180	45	193	32	15	119	36	26	88	M8
2	150	1/4	155	120	19	210	45	205	39	15	132	36	26	88	M8

Inch	Lift = Hx [mm]
1/2	7
3/4	10
1	13
1 1/4	15
1 1/2	19
2	23



PROGEF Plus oil free Diaphragm valve DIASTAR Ten FO (Fail safe to open) With fixed flanges PP-H JIS

Model:

- Material: PP-H / oil free cleaned
- Double flow rate compared to predecessor
- One housing nut replaces four screws
- Rotating air connection at 90° intervals
- Flat sealing faces/serrated
- Connecting dimension: JIS B2238/39 10K

Option:

- Individual configuration of the valve (see diagram)
- Comprehensive range of accessories available

* PN: PTFE

Working Pressure: **one side**

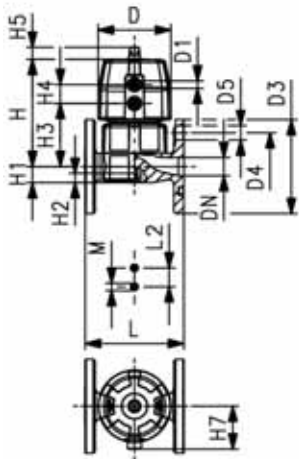

Inch	DN [mm]	PN* [bar]	kv-value (Δp=1 bar) [l/min]	EPDM Code	PTFE/EPDM Code	kg
1/2	15	10/10*	125	167 647 922	167 647 972	0.578
3/4	20	10/10*	271	167 647 923	167 647 973	0.934
1	25	10/10*	481	167 647 924	167 647 974	1.174
1 1/4	32	10/10*	759	167 647 925	167 647 975	1.891
1 1/2	40	10/10*	1263	167 647 926	167 647 976	3.647
2	50	10/10*	1728	167 647 927	167 647 977	4.290

Inch	D [mm]	D1_G [inch]	D3 [mm]	D4 [mm]	D5 [mm]	L [mm]	L2 [mm]	H [mm]	H1 [mm]	H2 [mm]	H3 [mm]	H4 [mm]	H5 [mm]	H7 [mm]	M
1/2	68	1/8	95	70	15	110	25	101	14	12	60	24	16	57	M6
3/4	96	1/8	100	75	15	120	25	132	18	12	73	25	16	57	M6
1	96	1/8	125	90	19	130	25	143	22	12	84	25	16	69	M6
1 1/4	120	1/8	135	100	19	180	45	173	26	15	99	26	26	88	M8
1 1/2	150	1/4	140	105	19	180	45	214	32	15	119	36	26	103	M8
2	150	1/4	155	120	19	210	45	226	39	15	132	36	26	103	M8

Inch	Lift = Hx [mm]
1/2	7
3/4	10
1	13
1 1/4	15
1 1/2	19
2	23



PROGEF Plus oil free Diaphragm valve DIASTAR Ten DA (Double acting) With fixed flanges PP-H JIS

Model:

- Material: PP-H / oil free cleaned
- Double flow rate compared to predecessor
- One housing nut replaces four screws
- Rotating air connection at 90° intervals
- Flat sealing faces/serrated
- Connecting dimension: JIS B2238/39 10K

Option:

- Individual configuration of the valve (see diagram)
- Comprehensive range of accessories available

* PN: PTFE

Working Pressure: **one side**

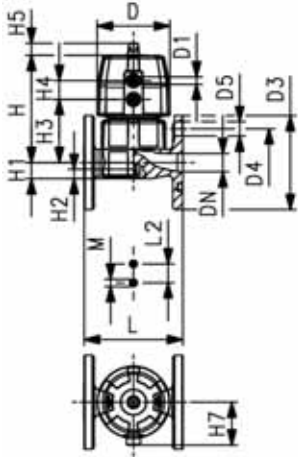

Inch	DN [mm]	PN* [bar]	kv-value ($\Delta p=1$ bar) [l/min]	EPDM Code	PTFE/EPDM Code	kg
½	15	10/10*	125	167 657 922	167 657 972	0.562
¾	20	10/10*	271	167 657 923	167 657 973	0.898
1	25	10/10*	481	167 657 924	167 657 974	1.144
1 ¼	32	10/10*	759	167 657 925	167 657 975	1.831
1 ½	40	10/10*	1263	167 657 926	167 657 976	2.897
2	50	10/10*	1728	167 657 927	167 657 977	3.540

Inch	D [mm]	D1_G [inch]	D3 [mm]	D4 [mm]	D5 [mm]	L [mm]	L2 [mm]	H [mm]	H1 [mm]	H2 [mm]	H3 [mm]	H4 [mm]	H5 [mm]	H7 [mm]	M
½	68	⅜	95	70	15	110	25	101	14	12	60	24	16	57	M6
¾	96	⅜	100	75	15	120	25	132	18	12	73	25	16	57	M6
1	96	⅜	125	90	19	130	25	143	22	12	84	25	16	69	M6
1 ¼	120	⅜	135	100	19	180	45	173	26	15	99	26	26	88	M8
1 ½	150	¼	140	105	19	180	45	214	32	15	119	36	26	103	M8
2	150	¼	155	120	19	210	45	226	39	15	132	36	26	103	M8

Inch	Lift = Hx [mm]
½	7
¾	10
1	13
1 ¼	15
1 ½	19
2	23



PROGEF Plus oil free Diaphragm valve DIASTAR TenPlus FC (Fail safe to close) low pressure With fixed flanges PP-H JIS

Model:

- Material: PP-H / oil free cleaned
- Double flow rate compared to predecessor
- One housing nut replaces four screws
- Rotating air connection at 90° intervals
- Flat sealing faces/serrated
- Connecting dimension: JIS B2238/39 10K

Option:

- Individual configuration of the valve (see diagram)
- Comprehensive range of accessories available

* PN: PTFE

Working Pressure: **both sides**

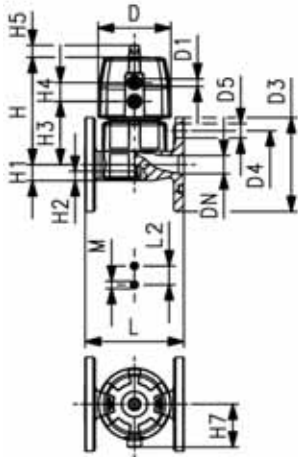

Inch	DN [mm]	PN* [bar]	kv-value ($\Delta p=1$ bar) [l/min]	EPDM Code	PTFE/EPDM Code	kg
1/2	15	10/8*	125	167 687 922	167 687 972	1.028
3/4	20	10/8*	271	167 687 923	167 687 973	1.108
1	25	10/8*	481	167 687 924	167 687 974	1.948
1 1/4	32	10/8*	759	167 687 925	167 687 975	3.321
1 1/2	40	10/8*	1263	167 687 926	167 687 976	5.145
2	50	10/6*	1728	167 687 927	167 687 977	5.787

Inch	D [mm]	D1_G [inch]	D3 [mm]	D4 [mm]	D5 [mm]	L [mm]	L2 [mm]	H [mm]	H1 [mm]	H2 [mm]	H3 [mm]	H4 [mm]	H5 [mm]	H7 [mm]	M
1/2	96	1/8	95	70	15	110	25	127	14	12	68	25	16	57	M6
3/4	96	1/8	100	75	15	120	25	132	18	12	73	25	16	57	M6
1	120	1/8	125	90	19	130	25	167	22	12	93	26	26	69	M6
1 1/4	150	1/4	135	100	19	180	45	196	26	15	101	36	26	88	M8
1 1/2	180	1/4	140	105	19	180	45	239	32	15	124	37	26	103	M8
2	180	1/4	155	120	19	210	45	251	39	15	137	37	26	103	M8

Inch	Lift = Hx [mm]
1/2	7
3/4	10
1	13
1 1/4	15
1 1/2	19
2	23



PROGEF Plus silicone free Diaphragm valve type 519 With butt fusion spigots SDR11 metric

Model:

- Material: PP-H / silicone free cleaned
- Double flow rate compared to predecessor
- One housing nut replaces four screws
- Handwheel with built-in locking mechanism
- Smallest possible dead space

Option:

- Individual configuration of the valve (see diagram)
- Self adjusting multifunctional module with integrated limit switches

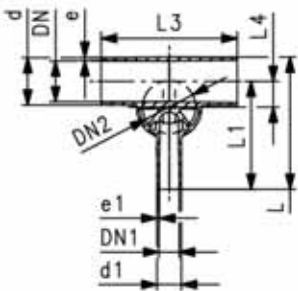
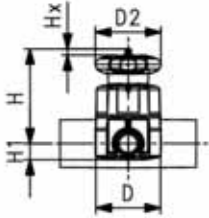

d [mm]	d1 [mm]	Valve Size d [mm]	DN [mm]	DN1 [mm]	DN2 [mm]	PN	kv-value ($\Delta p=1$ bar) [l/min]	EPDM Code	PTFE/EPDM Code	kg
20	20	20	15	15	15	10	57	167 519 201	167 519 701	0.321
25	20	25	20	15	20	10	89	167 519 203	167 519 703	0.397
25	25	25	20	20	20	10	118	167 519 204	167 519 704	0.399
32	20	25	25	15	20	10	80	167 519 207	167 519 707	0.424
32	25	25	25	20	20	10	105	167 519 208	167 519 708	0.426
32	32	32	25	25	25	10	231	167 519 209	167 519 709	0.980
40	20	32	32	15	25	10	85	167 519 212	167 519 712	1.008
50	20	25	40	15	20	10	86	167 519 218	167 519 718	0.485
50	25	32	40	20	25	10	160	167 519 219	167 519 719	1.054
50	32	32	40	25	25	10	206	167 519 220	167 519 720	1.056
63	20	25	50	15	20	10	84	167 519 225	167 519 725	0.524
63	25	32	50	20	25	10	150	167 519 226	167 519 726	1.097
63	32	32	50	25	25	10	184	167 519 227	167 519 727	1.100

d [mm]	D [mm]	D2 [mm]	L [mm]	L1 [mm]	L3 [mm]	L4 [mm]	H [mm]	Lift = Hx [mm]	e [mm]	e1 [mm]
20	65	65	117	96	162	12	75	7	1.9	1.9
25	80	65	133	108	162	16	80	10	2.3	1.9
25	80	65	133	108	162	16	80	10	2.3	2.3
32	80	65	142	120	162	19	84	10	2.9	1.9
32	80	65	142	120	162	19	84	10	2.9	2.3
32	88	87	145	120	160	19	107	13	2.9	2.9
40	88	87	149	128	180	23	115	13	3.7	1.9
50	80	65	160	134	180	27	97	10	4.6	1.9
50	88	87	160	134	180	28	120	13	4.6	2.3
50	88	87	160	134	180	28	120	13	4.6	2.9
63	80	65	177	144	180	33	104	10	5.8	1.9
63	88	87	177	144	180	35	127	13	5.8	2.3
63	88	87	177	144	180	35	127	13	5.8	2.9

Butterfly valves

PROGEF Plus silicone free Butterfly valve type 567 Hand lever with ratchet settings



Model:

- Material: PP-H / silicone free cleaned
- Up to DN 300: Overall length according to EN558 (DN 50-200: line 25, DN250, 300 line 16), ISO 5752
- Connecting dimension: ISO 7005 PN 10, EN 1092 PN 10, DIN 2501 PN 10, ANSI/ASME B 16.5 Class 150, BS 1560: 1989, BS 4504, JIS B 2220
- We recommend for the dimensions DN250 and DN300 only 6 bar maximum system pressure for the hand lever version

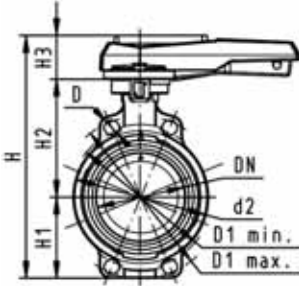

d [mm]	DN [mm]	Inch	PN	kv-value ($\Delta p=1$ bar) [l/min]	EPDM Code	FPM Code	kg
63	50	2	10	1470	167 567 402	167 567 422	0.969
75	65	2 ½	10	2200	167 567 403	167 567 423	1.270
90	80	3	10	3000	167 567 404	167 567 424	1.191
110	100	4	10	6500	167 567 405	167 567 425	1.751
140	125	5	10	11500	167 567 406	167 567 426	2.199
160	150	6	10	16600	167 567 407	167 567 427	2.989
225	200	8	10	39600	167 567 408	167 567 428	4.706

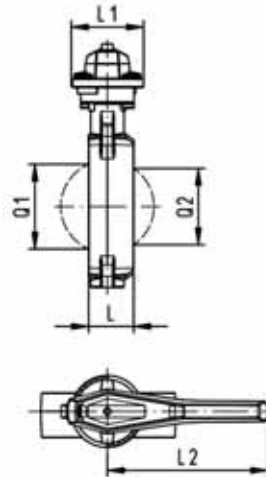

d [mm]	D [mm]	D1 min. [mm]	D1 max. [mm]	d2 [mm]	H [mm]	H1 [mm]	H2 [mm]	H3 [mm]	L [mm]	L1 [mm]	L2 [mm]	Q1 [mm]	Q2 [mm]
63	19	120.0	125.0	104	264	77	134	54	45	106	205	40	
75	19	139.7	145.0	115	277	83	140	54	46	106	205	54	35
90	19	150.0	160.0	131	289	89	146	54	49	106	205	67	50
110	19	175.0	190.5	161	325	104	167	55	56	106	255	88	74
140	23	210.0	215.9	187	352	117	181	55	64	106	255	113	97
160	24	241.3	241.3	215	373	130	189	55	72	106	255	139	123
225	23	290.0	295.0	267	435	158	210	67	73	140	408	178	169



PROGEF Plus oil free Butterfly valve type 567 Hand lever with ratchet settings

Model:

- Material: PP-H / oil free cleaned
- Connecting dimension: ISO 7005 PN 10, EN 1092 PN 10, DIN 2501 PN 10, ANSI/ASME B 16.5 Class 150, BS 1560: 1989, BS 4504, JIS B 2220
- Overall length according to EN 558, ISO 5752

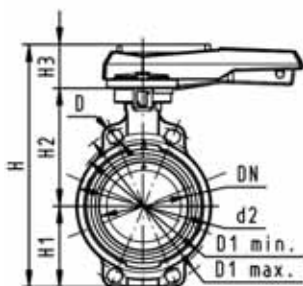

d [mm]	DN [mm]	Inch	PN	kv-value ($\Delta p=1$ bar) [l/min]	EPDM Code	kg
63	50	2	10	1470	167 567 502	0.965
75	65	2 ½	10	2200	167 567 503	1.056
90	80	3	10	3000	167 567 504	1.184
110	100	4	10	6500	167 567 505	1.737
140	125	5	10	11500	167 567 506	2.181
160	150	6	10	16600	167 567 507	2.966
225	200	8	10	39600	167 567 508	4.678

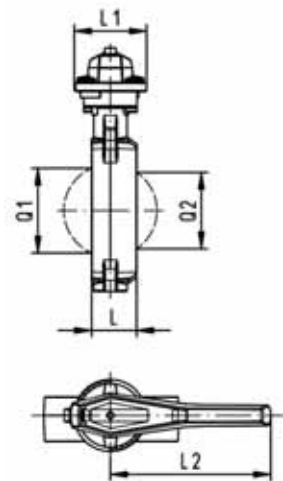

d [mm]	D [mm]	D1 min. [mm]	D1 max. [mm]	d2 [mm]	H [mm]	H1 [mm]	H2 [mm]	H3 [mm]	L [mm]	L1 [mm]	L2 [mm]	Q1 [mm]	Q2 [mm]
63	19	120.0	125.0	104	264	77	134	54	45	106	205	40	
75	19	139.7	145.0	115	277	83	140	54	46	106	205	54	35
90	19	150.0	160.0	131	289	89	146	54	49	106	205	67	50
110	19	175.0	190.5	161	325	104	167	55	56	106	255	88	74
140	23	210.0	215.9	187	352	117	181	55	64	106	255	113	97
160	24	241.3	241.3	215	373	130	189	55	72	106	255	139	123
225	23	290.0	295.0	267	435	158	210	67	73	140	408	178	169



PROGEF Plus silicone free Lugstyle butterfly valve type 568 Hand lever with ratchet settings

Model:

- Material: PP-H / silicone free cleaned
- Outer body in GGG-40.3 epoxy-coated
- Connecting dimension: ISO 7005 PN10, EN 1092 PN10, DIN 2501 PN10
- Overall length according to EN 558, ISO 5752

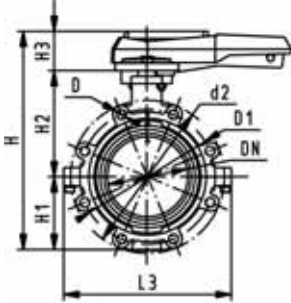

d [mm]	DN [mm]	Inch	PN	kv-value ($\Delta p=1$ bar) [l/min]	EPDM Code	FPM Code	kg
63	50	2	10	1470	167 568 402	167 568 422	3.055
75	65	2 ½	10	2200	167 568 403	167 568 423	3.397
90	80	3	10	3000	167 568 404	167 568 424	4.402
110	100	4	10	6500	167 568 405	167 568 425	5.835
140	125	5	10	11500	167 568 406	167 568 426	7.665
160	150	6	10	16600	167 568 407	167 568 427	9.449
225	200	8	10	39600	167 568 408	167 568 428	14.654

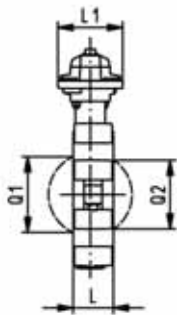

d [mm]	d2 [mm]	D	D1 [mm]	H [mm]	H1 [mm]	H2 [mm]	H3 [mm]	L [mm]	L1 [mm]	L2 [mm]	L3 [mm]	Q1 [mm]	Q2 [mm]
63	150	M16	125	265	77	134	54	45	106	205	150	40	
75	170	M16	145	277	83	140	54	46	106	205	160	54	35
90	184	M16	160	289	89	146	54	49	106	205	205	67	50
110	216	M16	180	326	104	167	55	56	106	255	244	88	74
140	246	M16	210	353	117	181	55	64	106	255	272	113	97
160	273	M20	240	374	130	189	55	72	106	255	297	139	123
225	334	M20	295	435	158	210	67	73	140	408	360	178	169

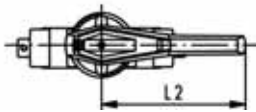



PROGEF Plus silicone free Lugstyle butterfly valve 568 ANSI Hand lever with ratchet settings

Model:

- Material: PP-H / silicone free cleaned
- Outer body in GGG-40.3 epoxy-coated
- Connecting dimension ANSI/ASME B 16.5 Class 150
- Overall length according to EN 558, ISO 5752

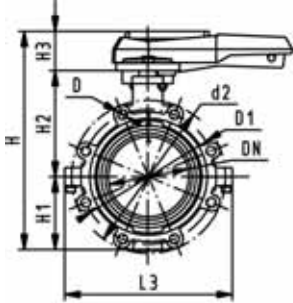

Inch	d [mm]	DN [mm]	PN	kv-value ($\Delta p=1$ bar) [l/min]	EPDM Code	FPM Code	kg
2	63	50	10	1470	167 568 502	167 568 522	3.055
2 ½	75	65	10	2200	167 568 503	167 568 523	3.397
3	90	80	10	3000	167 568 504	167 568 524	3.773
4	110	100	10	6500	167 568 505	167 568 525	5.835
5	140	125	10	11500	167 568 506	167 568 526	7.665
6	160	150	10	16600	167 568 507	167 568 527	9.449
8	225	200	10	39600	167 568 508	167 568 528	14.654

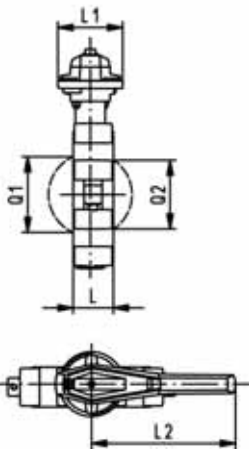

Inch	d2 [mm]	D	D1 [mm]	H [mm]	H1 [mm]	H2 [mm]	H3 [mm]	L [mm]	L1 [mm]	L2 [mm]	L3 [mm]	Q1 [mm]	Q2 [mm]
2	150	UNC 5/8	121	265	77	134	54	45	106	205	150	40	
2 ½	170	UNC 5/8	138	277	83	140	54	46	106	205	160	54	35
3	177	UNC 5/8	152	289	89	146	54	49	106	205	175	67	50
4	216	UNC 5/8	191	326	104	167	55	56	106	255	244	88	74
5	246	UNC 3/4	216	353	117	181	55	64	106	255	272	113	97
6	273	UNC 3/4	241	374	130	189	55	72	106	255	297	139	123
8	334	UNC 3/4	298	435	158	210	67	73	140	408	360	178	169

Cone check valves

PROGEF Plus silicone free Check valve type 561 With fusion sockets metric



Model:

- Material: PP-H / silicone free cleaned
- Designed for easy installation and removal
- Vibration free even at high flow velocity
- Flow-optimized return cone, double guided
- For vertical installation
- Compact installation length, same as ball valve type 546
- Z-length, end connectors and union nuts **not** compatible with type 360

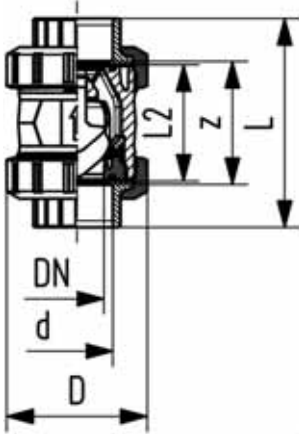

d [mm]	DN [mm]	PN	kv-value ($\Delta p=1$ bar) [l/min]	EPDM Code	FPM Code	kg	D [mm]	L [mm]	L2 [mm]	z [mm]
16	10	10	190	167 561 201	167 561 211	0.080	50	93	56	67
20	15	10	180	167 561 202	167 561 212	0.080	50	95	56	66
25	20	10	380	167 561 203	167 561 213	0.180	58	109	65	77
32	25	10	460	167 561 204	167 561 214	0.190	68	119	71	83
40	32	10	850	167 561 205	167 561 215	0.340	84	135	85	99
50	40	10	1080	167 561 206	167 561 216	0.480	97	147	89	105
63	50	10	1670	167 561 207	167 561 217	0.880	124	168	101	117
75	65	10	2950	167 561 208	167 561 218	2.310	166	233	136	167
90	80	10	3600	167 561 209	167 561 219	3.580	200	254	141	180
110	100	10	4150	167 561 210	167 561 220	5.930	238	301	164	215

PROGEF Plus silicone free Check valve type 561 With socket fusion spigots metric



Model:

- Material: PP-H / silicone free cleaned
- Designed for easy installation and removal
- Vibration free even at high flow velocity
- Flow-optimized return cone, double guided
- For vertical installation
- Compact installation length, same as ball valve type 546
- Z-length, end connectors and union nuts **not** compatible with type 360

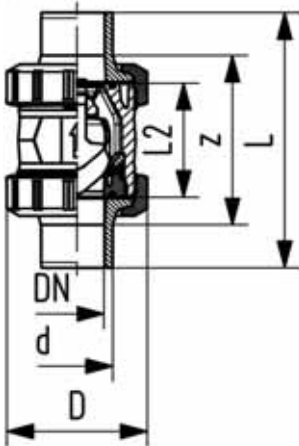

d [mm]	DN [mm]	PN	kv-value ($\Delta p=1$ bar) [l/min]	EPDM Code	FPM Code	kg	D [mm]	L [mm]	L2 [mm]	L3 [mm]
16	10	10	190	167 561 221	167 561 231	0.080	50	110	56	
20	15	10	180	167 561 222	167 561 232	0.090	50	120	56	130
25	20	10	380	167 561 223	167 561 233	0.190	58	139	65	150
32	25	10	460	167 561 224	167 561 234	0.200	68	150	71	160
40	32	10	850	167 561 225	167 561 235	0.350	84	170	85	180
50	40	10	1080	167 561 226	167 561 236	0.510	97	190	89	200
63	50	10	1670	167 561 227	167 561 237	0.950	124	220	101	230
75	65	10	2950	167 561 228	167 561 238	2.370	166	280	136	290
90	80	10	3600	167 561 229	167 561 239	3.750	200	296	141	310
110	100	10	4150	167 561 230	167 561 240	5.980	238	336	164	350



PROGEF Plus silicone free Check valve type 561 With butt fusion spigots IR-Plus SDR11 metric

Model:

- Material: PP-H / silicone free cleaned
- Designed for easy installation and removal
- Vibration free even at high flow velocity
- Flow-optimized return cone, double guided
- For vertical installation
- Compact installation length, same as ball valve type 546
- Z-length, end connectors and union nuts **not** compatible with type 360

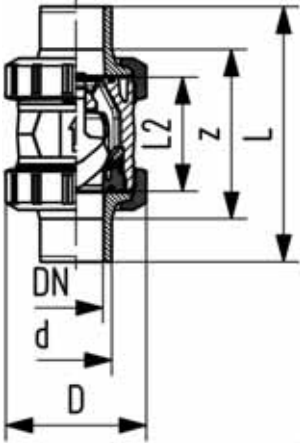

d [mm]	DN [mm]	PN	kv-value ($\Delta p=1$ bar) [l/min]	EPDM Code	FPM Code	kg	D [mm]	L [mm]	L2 [mm]	e [mm]
20	15	10	180	167 561 242	167 561 252	0.080	50	130	56	1.9
25	20	10	380	167 561 243	167 561 253	0.180	58	143	65	2.3
32	25	10	460	167 561 244	167 561 254	0.190	68	150	71	3.0
40	32	10	850	167 561 245	167 561 255	0.340	84	171	85	3.7
50	40	10	1080	167 561 246	167 561 256	0.490	97	191	89	4.6
63	50	10	1670	167 561 247	167 561 257	0.930	124	220	101	5.8
75	65	10	2950	167 561 248	167 561 258	2.360	166	266	136	6.8
90	80	10	3600	167 561 249	167 561 259	3.680	200	264	141	8.2
110	100	10	4150	167 561 250	167 561 260	5.830	238	301	164	10.0



PROGEF Plus silicone free Check valve type 562 With fusion sockets metric

Model:

- Material: PP-H / silicone free cleaned
- Spring loaded, spring made of stainless steel (1.4310)
- Spring available in other materials, see spare parts
- Designed for easy installation and removal
- Vibration free even at high flow velocity
- Flow-optimized return cone, double guided
- For horizontal or vertical installation
- Compact installation length, same as ball valve type 546
- Z-length, end connectors and union nuts **not** compatible with type 360

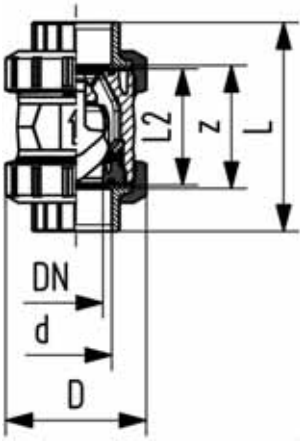

d [mm]	DN [mm]	PN	kv-value ($\Delta p=1$ bar) [l/min]	EPDM Code	FPM Code	kg	D [mm]	L [mm]	L2 [mm]	z [mm]
16	10	10	190	167 562 201	167 562 211	0.080	50	93	56	67
20	15	10	180	167 562 202	167 562 212	0.080	50	95	56	66
25	20	10	380	167 562 203	167 562 213	0.180	58	109	65	77
32	25	10	460	167 562 204	167 562 214	0.190	68	119	71	83
40	32	10	850	167 562 205	167 562 215	0.340	84	135	85	99
50	40	10	1080	167 562 206	167 562 216	0.480	97	147	89	105
63	50	10	1670	167 562 207	167 562 217	0.880	124	168	101	117
75	65	10	2950	167 562 208	167 562 218	2.310	166	233	136	167
90	80	10	3600	167 562 209	167 562 219	3.580	200	254	141	180
110	100	10	4150	167 562 210	167 562 220	5.930	238	301	164	215

PROGEF Plus silicone free Check valve type 562 With socket fusion spigots metric



Model:

- Material: PP-H / silicone free cleaned
- Spring loaded, spring made of stainless steel (1.4310)
- Spring available in other materials, see spare parts
- Designed for easy installation and removal
- Vibration free even at high flow velocity
- Flow-optimized return cone, double guided
- For horizontal or vertical installation
- Compact installation length, same as ball valve type 546
- Z-length, end connectors and union nuts **not** compatible with type 360

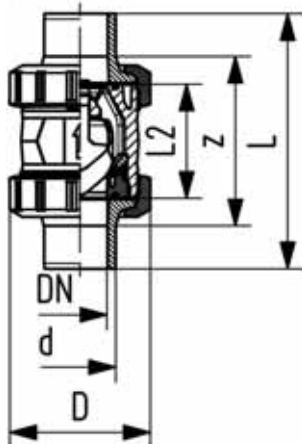

d [mm]	DN [mm]	PN	kv-value ($\Delta p=1$ bar) [l/min]	EPDM Code	FPM Code	kg	D [mm]	L [mm]	L2 [mm]
16	10	10	190	167 562 221	167 562 231	0.080	50	110	56
20	15	10	180	167 562 222	167 562 232	0.090	50	120	56
25	20	10	380	167 562 223	167 562 233	0.190	58	139	65
32	25	10	460	167 562 224	167 562 234	0.200	68	150	71
40	32	10	850	167 562 225	167 562 235	0.350	84	170	85
50	40	10	1080	167 562 226	167 562 236	0.510	97	190	89
63	50	10	1670	167 562 227	167 562 237	0.950	124	220	101
75	65	10	2950	167 562 228	167 562 238	2.370	166	280	136
90	80	10	3600	167 562 229	167 562 239	3.750	200	296	141
110	100	10	4150	167 562 230	167 562 240	5.980	238	336	164

PROGEF Plus silicone free Check valve type 562 With butt fusion spigots IR-Plus SDR11 metric



Model:

- Material: PP-H / silicone free cleaned
- Spring loaded, spring made of stainless steel (1.4310)
- Spring available in other materials, see spare parts
- Designed for easy installation and removal
- Vibration free even at high flow velocity
- Flow-optimized return cone, double guided
- For horizontal or vertical installation
- Compact installation length, same as ball valve type 546
- Z-length, end connectors and union nuts **not** compatible with type 360

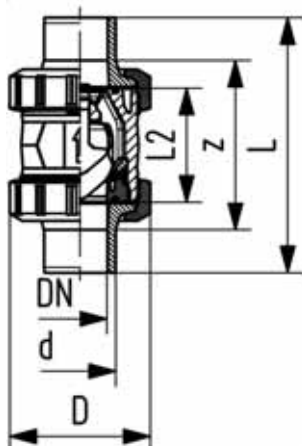

d [mm]	DN [mm]	PN	kv-value ($\Delta p=1$ bar) [l/min]	EPDM Code	FPM Code	kg	D [mm]	L [mm]	L2 [mm]	e [mm]
20	15	10	180	167 562 242	167 562 252	0.080	50	130	56	1.9
25	20	10	380	167 562 243	167 562 253	0.180	58	143	65	2.3
32	25	10	460	167 562 244	167 562 254	0.190	68	150	71	3.0
40	32	10	850	167 562 245	167 562 255	0.340	84	171	85	3.7
50	40	10	1080	167 562 246	167 562 256	0.490	97	191	89	4.6
63	50	10	1670	167 562 247	167 562 257	0.930	124	220	101	5.8
75	65	10	2950	167 562 248	167 562 258	2.360	166	266	136	8.2
90	80	10	3600	167 562 249	167 562 259	3.680	200	264	141	9.9
110	100	10	4150	167 562 250	167 562 260	5.830	238	301	164	12.0

PE 100



- Pipes
- Socket Fusion Fittings
- Butt Fusion Fittings
- Electrofusion Fittings

Pressure Ratings for PE-Fittings and PE-Pipes

	SDR11	SDR17.6
PE 80 C = 1.25	PN12.5	PN7.5
PE 80 C = 1.6	PN10	PN6
PE 100 C = 1.25	PN16	PN10
PE 100 C = 1.6	PN12.5	PN7.5

Polyethylene PE 100 – the third Generation of polyethylene

Pressure/temperature diagram for PE PE 100

The following pressure/temperature diagram for PE100 pipes and fittings is valid for a lifetime of 25 years.

The design factor of 1.6 (respective 1.25) recommended by GF is incorporated.

It can be used for water or media resembling water, in other words, media which have no derating factor regarding the chemical resistance.

Remark: Please take into account the pressure/temperature diagrams for valves and special fittings. Because of the construction and/or sealing material used, differences are possible when compared with pipes and fittings. This information can be found in the planning fundamentals of the relevant types of valves, respectively special fittings.

In case of long-term applications at continuous pressure with temperatures above 40 °C, please contact your GF representative.

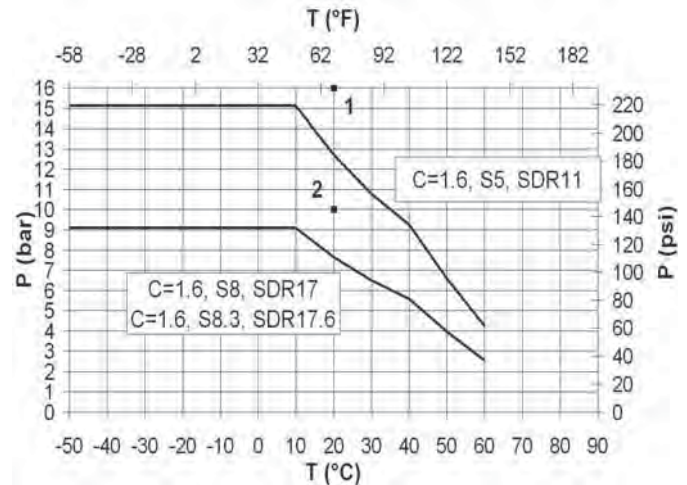

1 Design Factor C = 1.25, S5, SDR11 for 20 °C water, 50 years
 2 Design Factor C=1.25, S8.3, SDR17.6 and S8, SDR17 for 20°C water, 50 years
 P Permissible pressure in bar, psi
 T Temperature in °C, °F

Pressure/temperature diagram for PE PE 80

The following pressure/temperature diagram for PE80 pipes and fittings is valid for a lifetime of 25 years.

The design factor of 1.6 recommended by GF is incorporated.

It can be used for water or media resembling water, in other words, media which have no derating factor regarding the chemical resistance.

Remark: Please take into account the pressure/temperature diagrams for valves and special fittings. Because of the construction and/or sealing material used, differences are possible when compared with pipes and fittings. This information can be found in the planning fundamentals of the relevant types of valves, respectively special fittings.

In case of long-term applications at continuous pressure with temperatures above 40 °C please contact your GF representative.

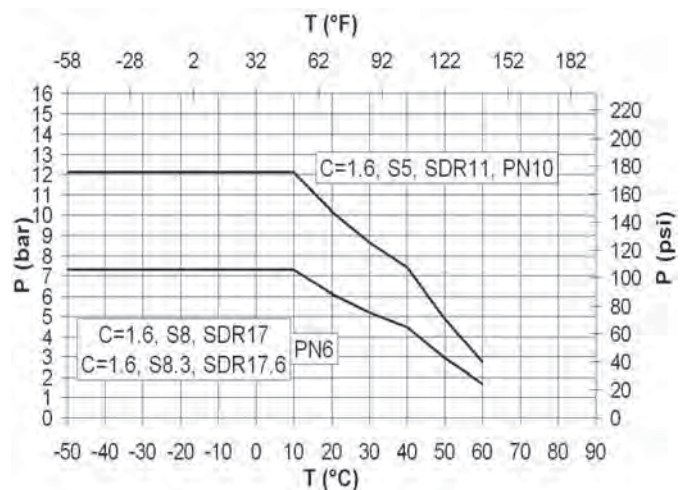

P Permissible pressure in bar, psi
 T Temperature in °C, °F

Comparison of nominal pressure for SDR17 and SDR17.6

Ascertaining the nominal pressure (PN)

According to the standard, the nominal pressure is a numeric measure of the size of a pipeline part, which refers to the mechanical properties of that pipeline part. Besides the geometric sizes such as SDR, the creep strength/dimensioning tension and the minimum design factor are also taken into consideration.

For plastic piping systems intended to carry water, the nominal pressure value indicates the maximum permitted operating pressure in bar, at a temperature of 20°C, and 50 years in water, referenced to the minimum value of the total (calculation) coefficients. It is calculated using the following equation:

$$[PN] = 10 \cdot \sigma_S / [S] = 20 \cdot \sigma_S / (SDR - 1) \quad (\sigma_S \text{ in MPa, PN in bar})$$

Minimum required strength (MRS):

The value of σ_{LCL} at 20°C and 50 years in water, rounded down to the next value in the R10 standard series of numbers.

σ_{LCL} is understood to mean the equivalent stress ascertained for a given period and a given temperature from the time-dependent creep diagram. LCL stands for Lower Confidence Limit. The R10 standard series of numbers is a Renard standard series of numbers as per ISO 3 and ISO 497.

Design stress (σ_S):

The permitted stress for a particular application or operating conditions stated in megapascal. It is derived by dividing the MRS by coefficient C and is calculated as shown in the equation below:

$$\sigma_S = MRS / C$$

The calculated value is rounded down to the next value in the R10 standard series of numbers.

Total operating (calculation) coefficient (C):

A total coefficient having a value greater than one, which takes into account both the operating conditions and also the characteristics of the pipeline component that have not yet been entered into the lower confidence limit σ_{LCL} .

If we use the above definition to calculate the relevant nominal pressure for both SDR classes, the result for a PE 100 pipe is as follows:

SDR17	SDR17.6
MRS = 10 MPa	MRS = 10 MPa
C = 1.25 (minimum factor)	C = 1.25 (minimum factor)
$\sigma = 8.0$ MPa	$\sigma = 8.0$ MPa
PN = 10 bar	PN = 9.6 bar

The above definitions thus produce a difference of 0.4 bar in PN, but in actual practice this does not matter, as shown below:

1.) Industrial pipelines are normally designed for a service life of 25 years. If from the time-dependent creep diagrams we ascertain for ELTEX TUB 121 or CRP 100 an equivalent stress of σ_{LCL} for the operating point of 25 years and 20°C, we obtain a tension of 10.6 MPa (minimum value of both PE100 materials as per manufacturer's data).

2.) If we use this tension to ascertain the dimensioning tension σ_S , and do not round it down, we obtain the value of 8.48 MPa.

3.) Thus the actual nominal pressure in practice is:

for SDR 17 => PN = 10.6 bar and for
SDR 17.6 => PN = 10.2 bar.

To summarise: Both SDR classes comply with requirements for industrial applications mentioning a PN10 system.

Comparison of geometric dimensions

The two SDR classes differ only slightly in wall thickness, as can be seen from the diagram below. This shows that there is an area where the wall thickness complies with both requirements of both SDR classes.

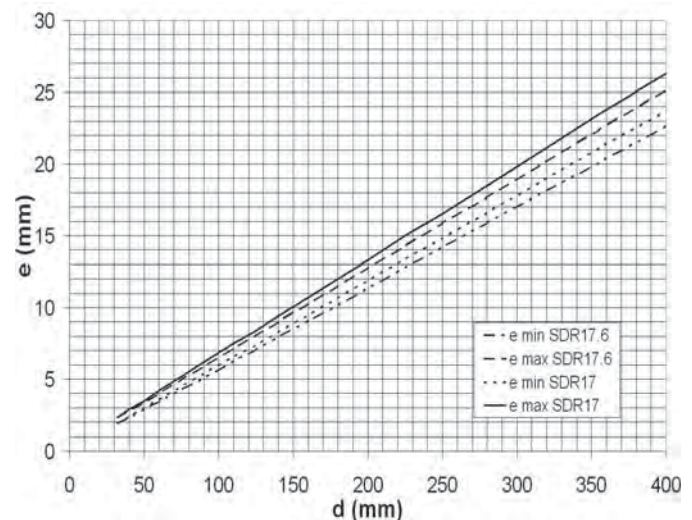

d Outside pipe diameter
e Wall thickness

For butt fusion the wall thickness gap may not exceed 10%. Looking at the differences of the wall thicknesses of SDR17 and SDR17.6 the resulting gap is much lower, that means butt fusion of both SDR's is no problem.

PE Industrial Systems Pipes, Fittings, Unions, Flanges and Flange Adaptors

		Page
	PE100 pipes	388
	Fittings for Socket Fusion	390
	Adaptor Fittings for Socket Fusion	392
	Unions for Socket Fusion	394
	Flange Adaptors, Flanges and Gaskets for Socket Fusion	396
	Fittings for Butt Fusion	402
	Adaptor Fittings for Butt Fusion	420
	Unions for butt fusion	424
 <small>Type A</small>	Flange Adaptors, Flanges and Gaskets for Butt Fusion	429
	Electrofusion Fittings	442
	Spigot Fittings for Electrofusion	461

PE100 pipes

93 01 71

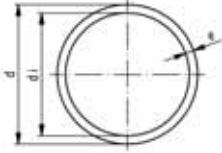

Pipe PE100 S5/SDR11

Model:

- Material: PE 100, Polyethylene
- Colour: RAL 9011 graphite black
- Dimension: DIN 8074
- Pipe length: 5m, with plain ends

* In these two sizes, stiffeners Code No. 733 900 006 (20 x 1,9) and 733 900 007 (25 x 2.3) must be used with socket fusion joints.

d [mm]	PN	Code	kg/m	e [mm]	di [mm]
* 20	16	193 017 156	0.113	1,9	16.2
* 25	16	193 017 157	0.173	2,3	20.4
32	16	193 017 158	0.274	2,9	26.2
40	16	193 017 159	0.434	3,7	32.6
50	16	193 017 160	0.673	4,6	40.8
63	16	193 017 161	1.060	5,8	51.4
75	16	193 017 162	1.480	6,8	61.4
90	16	193 017 163	2.140	8,2	73.6
110	16	193 017 164	3.180	10,0	90.0
125	16	193 017 165	4.120	11,4	102.8
140	16	193 017 166	5.130	12,7	114.6
160	16	193 017 167	6.740	14,6	130.8
180	16	193 017 168	8.510	16,4	147.2
200	16	193 017 169	10.500	18,2	163.6
225	16	193 017 170	13.300	20,5	184.0
250	16	193 017 171	16.300	22,7	204.6
280	16	193 017 172	20.500	25,4	229.2
315	16	193 017 173	25.900	28,6	257.8
355	16	193 017 174	32.900	32,2	290.6
400	16	193 017 175	41.700	36,3	327.4

33 90 00

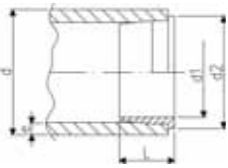

Stiffener PE100

Model:

- Material: PE100
- Used as support during d20 and d25 socket fusion jointing to prevent the pipe from collapsing during the heating and jointing process.

d [mm]	Code	L [mm]	e [mm]	d1 [mm]	D2 [mm]	d2 [mm]
20	733 900 006	10	1,9	14	18	18
25	733 900 007	11	2,3	18	22	23

93 01 72

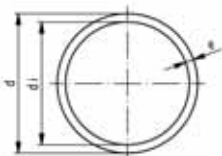

Pipe PE100 S3.2/SDR7.4

Model:

- Dimension: DIN 8074
- Colour: RAL 9011 graphite black
- Length: 5 m
- for socket fusion without stiffeners
- Not suitable for butt fusion

d [mm]	Code	kg/m	e [mm]	di [mm]
20	193 017 206	0.156	2,8	14.4
25	193 017 207	0.243	3,5	18.0

93 01 71

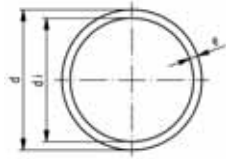

Pipe PE100 S8.3/SDR17.6

Model:

- Material: PE 100, Polyethylene
- Colour: RAL 9011 graphite black
- Dimension: DIN 8074
- Pipe length: 5m, with plain ends

d [mm]	PN	Code	kg/m	e [mm]	di [mm]
50	10	193 017 110	0.445	2,9	44.2
63	10	193 017 111	0.695	3,6	55.8
75	10	193 017 112	0.987	4,3	66.4
90	10	193 017 113	1.400	5,1	79.8
110	10	193 017 114	2.100	6,3	97.4
125	10	193 017 115	2.690	7,1	110.8
140	10	193 017 116	3.370	8,0	124.0
160	10	193 017 117	4.400	9,1	141.8
180	10	193 017 118	5.540	10,2	159.6
200	10	193 017 119	6.860	11,4	177.2
225	10	193 017 120	8.640	12,8	199.4
250	10	193 017 121	10.700	14,2	221.6
280	10	193 017 122	13.300	15,9	248.2
315	10	193 017 123	16.900	17,9	279.2
355	10	193 017 124	21.400	20,1	314.8
400	10	193 017 125	27.200	22,7	354.6
450	10	193 017 126	34.300	25,5	400.0
500	10	193 017 127	42.500	28,4	443.2

Fittings for Socket Fusion

33 10 01

Elbow 90° PE80

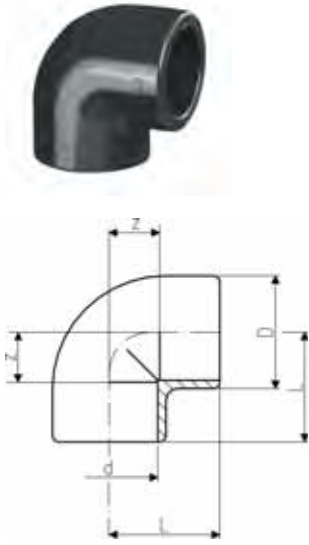

d [mm]	PN	Code	kg	kg/m	D [mm]	L [mm]	z [mm]
20	10	733 100 106	0.022	0.022	31	28	14
25	10	733 100 107	0.031	0.031	36	32	16
32	10	733 100 108	0.048	0.048	44	38	20
40	10	733 100 109	0.078	0.078	54	44	24
50	10	733 100 110	0.129	0.129	66	51	28
63	10	733 100 111	0.228	0.228	82	62	35
75	10	733 100 112	0.311	0.311	93	76	45
90	10	733 100 113	0.498	0.498	110	88	53
110	10	733 100 114	0.864	0.864	134	106	65

33 15 01

Elbow 45° PE80



d [mm]	PN	Code	kg	kg/m	D [mm]	L [mm]	z [mm]
20	10	733 150 106	0.018	0.018	31	21	7
25	10	733 150 107	0.026	0.026	36	24	8
32	10	733 150 108	0.043	0.043	44	28	10
40	10	733 150 109	0.061	0.061	53	33	13
50	10	733 150 110	0.087	0.087	64	36	13
63	10	733 150 111	0.184	0.184	82	43	16
75	10	733 150 112	0.229	0.229	93	51	20
90	10	733 150 113	0.357	0.357	114	58	23
110	10	733 150 114	0.653	0.653	134	68	27

33 20 01

Tee 90° equal PE80

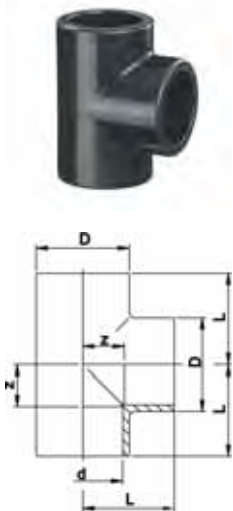

d [mm]	PN	Code	kg	kg/m	D [mm]	L [mm]	z [mm]
20	10	733 200 106	0.028	0.028	31	28	14
25	10	733 200 107	0.041	0.041	36	32	16
32	10	733 200 108	0.060	0.060	44	38	20
40	10	733 200 109	0.100	0.100	54	44	24
50	10	733 200 110	0.166	0.166	66	51	28
63	10	733 200 111	0.298	0.298	82	62	35
75	10	733 200 112	0.409	0.409	93	76	45
90	10	733 200 113	0.749	0.749	114	88	53
110	10	733 200 114	1.112	1.112	134	106	65

33 91 01

Sockets equal, PE80



d [mm]	PN	Code	kg	kg/m	D [mm]	L [mm]	z [mm]
20	10	733 910 106	0.014	0.014	31	35	7
25	10	733 910 107	0.018	0.018	36	39	7
32	10	733 910 108	0.027	0.027	44	43	7
40	10	733 910 109	0.043	0.043	54	48	8
50	10	733 910 110	0.074	0.074	66	54	8
63	10	733 910 111	0.124	0.124	82	62	8
75	10	733 910 112	0.152	0.152	93	70	8
90	10	733 910 113	0.234	0.234	112	81	11
110	10	733 910 114	0.419	0.419	134	96	14

33 91 03

Reducers, PE80

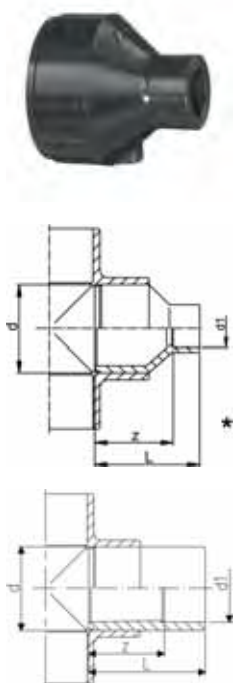

d [mm]	d1 [mm]	PN	Code	kg	kg/m	L [mm]	z [mm]
25	20	10	733 910 337	0.013	0.013	39	23
32	25	10	733 910 341	0.021	0.021	43	27
* 40	20	10	733 910 348	0.023	0.023	48	34
* 40	25	10	733 910 347	0.027	0.027	48	32
40	32	10	733 910 346	0.032	0.032	48	30
* 50	32	10	733 910 353	0.042	0.042	54	36
50	40	10	733 910 352	0.049	0.049	54	34
* 63	20	10	733 910 362	0.057	0.057	64	50
* 63	25	10	733 910 361	0.060	0.060	64	48
* 63	32	10	733 910 360	0.064	0.064	64	46
* 63	40	10	733 910 359	0.070	0.070	64	44
63	50	10	733 910 358	0.086	0.086	64	41
75	63	10	733 910 364	0.103	0.103	62	35
* 90	63	10	733 910 371	0.180	0.180	88	62
90	75	10	733 910 370	0.144	0.144	70	39
110	90	10	733 910 376	0.254	0.254	81	45

33 96 01

End Caps, PE80



d [mm]	PN	Code	kg	kg/m	D [mm]	L [mm]
20	10	733 960 106	0.010	0.010	30	27
25	10	733 960 107	0.016	0.016	36	30
32	10	733 960 108	0.025	0.025	44	34
40	10	733 960 109	0.038	0.038	53	38
50	10	733 960 110	0.061	0.061	65	44
63	10	733 960 111	0.097	0.097	80	51
75	10	733 960 112	0.150	0.150	91	66
90	10	733 960 113	0.274	0.274	111	77
110	10	733 960 114	0.405	0.405	137	93

Adaptor Fittings for Socket Fusion

33 10 02

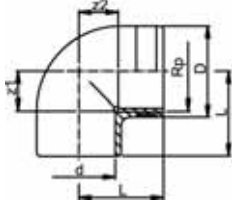

Elbow 90°, PE80 metric - Rp

Model:

- With fusion socket metric and parallel female thread Rp, reinforced
- Reinforcing ring stainless (A2)
- Connection to plastic or metal threads
- Do not use thread sealing pastes that are harmful to PE
- Install with low mechanical stress and avoid large cyclic temperature changes

d [mm]	Rp [inch]	PN	Code	kg	kg/m	D [mm]	L [mm]	z1 [mm]	z2 [mm]
20	1/2	10	733 100 206	0.024	0.024	30	28	14	14
25	3/4	10	733 100 207	0.033	0.033	35	32	16	16
32	1	10	733 100 208	0.061	0.061	44	38	20	20
40	1 1/4	10	733 100 209	0.094	0.094	54	44	24	24

33 91 02

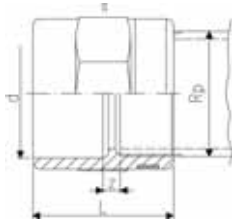

Adaptor Sockets, PE80 metric - Rp

Model:

- With fusion socket metric and parallel female thread Rp, reinforced
- Reinforcing ring stainless (A2)
- Connection to plastic or metal threads
- Do not use thread sealing pastes that are harmful to PE
- Install with low mechanical stress and avoid large cyclic temperature changes

d [mm]	Rp [inch]	PN	Code	kg	kg/m	L [mm]	s [mm]	z [mm]
20	1/2	10	733 910 206	0.020	0.020	35	32	7
25	3/4	10	733 910 207	0.026	0.026	39	36	7
32	1	10	733 910 208	0.042	0.042	45	46	7
40	1 1/4	10	733 910 209	0.068	0.068	53	55	7
50	1 1/2	10	733 910 210	0.098	0.098	54	65	9
63	2	10	733 910 211	0.155	0.155	62	80	9

33 91 04

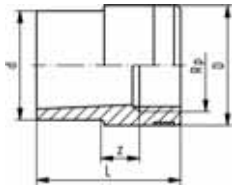

Reducing bush PE80 metric Rp

Model:

- With fusion spigot metric and BSP parallel female thread, reinforced
- Reinforcing ring stainless (A2)
- Connection to plastic or metal threads
- Do not use thread sealing pastes that are harmful to PE
- Install with low mechanical stress and avoid large cyclic temperature changes

d [mm]	Rp [inch]	PN	Code	kg	kg/m	L [mm]	z [mm]
20	3/8	10	733 910 434	0.012	0.012	33	7
25	1/2	10	733 910 437	0.015	0.015	37	6
32	3/4	10	733 910 441	0.028	0.028	43	8
40	1	10	733 910 446	0.046	0.046	49	9
50	1 1/4	10	733 910 452	0.071	0.071	55	10

53 96 04

Hose connector PE100 metric

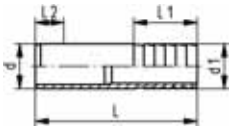

Model:

- With socket fusion spigot metric and parallel hose connection

d [mm]	d1 [mm]	PN	Code	kg	kg/m	L [mm]	L1 [mm]	L2 [mm]
20	20	10	753 960 406	0.006	0.006	55	27	14
25	25	10	753 960 407	0.015	0.015	68	36	16
32	32	10	753 960 408	0.024	0.024	77	36	18
40	40	10	753 960 409	0.035	0.035	80	42	20
50	50	10	753 960 410	0.056	0.056	90	48	23
63	60	10	753 960 411	0.093	0.093	100	50	27

Unions for Socket Fusion

33 58 01

Adapter union PE80 - PE80 metric

Model:

- Union End: Fusion socket, PE80 metric
- Union Bush: Brass with fusion socket insert, PE80 metric
- Union Nut: brass
- Gasket: O-ring NBR (Nitrile-rubber)



d [mm]	d1 [mm]	PN	Code	kg	kg/m	G [inch]	L [mm]	z1 [mm]	D2 [mm]	d2 [mm]	z2 [mm]
20	20	10	733 580 106	0.163	0.163	1 1/4	46	6	46	46	3
25	25	10	733 580 107	0.214	0.214	1 1/2	49	6	52	52	3
32	32	10	733 580 108	0.294	0.294	2	51	6	64	64	3
40	40	10	733 580 109	0.473	0.473	2 1/2	56	8	79	79	3
50	50	10	733 580 110	0.491	0.491	2 2/3	61	8	85	85	3
63	63	10	733 580 111	0.730	0.730	3 1/2	69	8	104	104	3

33 58 02

Adaptor union PE80 - brass metric Rp

Model:

- Union End: Fusion socket, PE80 metric
- Union bush: nickel-plated, parallel female thread Rp
- Union Nut: brass
- Gasket: O-ring NBR (Nitrile-rubber)



d [mm]	Rp [inch]	PN	Code	kg	kg/m	G [inch]	L [mm]	d1 [mm]	z1 [mm]	z2 [mm]
20	1/2	10	733 580 206	0.209	0.209	1 1/4	46	46	6	10
25	3/4	10	733 580 207	0.269	0.269	1 1/2	48	52	6	9
32	1	10	733 580 208	0.376	0.376	2	51	64	6	8
40	1 1/4	10	733 580 209	0.596	0.596	2 1/2	56	79	8	7
50	1 1/2	10	733 580 210	0.666	0.666	2 3/4	59	85	8	7
63	2	10	733 580 211	0.960	0.960	3 1/2	65	104	8	5

33 58 07

Adaptor union PE80 - brass metric R

Model:

- Union End: Fusion socket, PE80 metric
- Union bush: nickel-plated, taper male thread R
- Union Nut: brass
- Gasket: O-ring NBR (Nitrile-rubber)



d [mm]	R [inch]	PN	Code	kg	kg/m	d1 [mm]	G [inch]	L [mm]	L1 [mm]	z [mm]
20	1/2	10	733 580 706	0.260	0.260	46	1 1/4	62	40	6
25	3/4	10	733 580 707	0.324	0.324	52	1 1/2	65	41	6
32	1	10	733 580 708	0.470	0.470	64	2	71	45	6
40	1 1/4	10	733 580 709	0.754	0.754	79	2 1/2	78	48	8
50	1 1/2	10	733 580 710	0.781	0.781	85	2 3/4	81	43	8
63	2	10	733 580 711	1.166	1.166	104	3 1/2	91	54	8

34 60 01

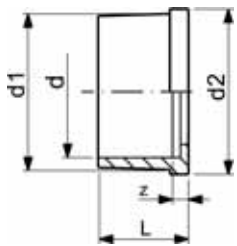

Union end PE80

Model:

- With fusion socket metric
- Suitable for unions, tank connectors and diaphragm valves Type 514

d [mm]	PN	Code	kg	kg/m	d1 [mm]	d2 [mm]	L [mm]	L1 [mm]	z [mm]
20	10	734 600 106	0.006	0.006	28	30	19	5	5
25	10	734 600 107	0.013	0.013	36	39	21	5	5
32	10	734 600 108	0.015	0.015	42	45	23	6	5
40	10	734 600 109	0.026	0.026	53	57	25	6	5
50	10	734 600 110	0.025	0.025	59	63	28	7	5
63	10	734 600 111	0.044	0.044	74	79	32	8	5

EPDM 48 41 00
FPM 49 41 00

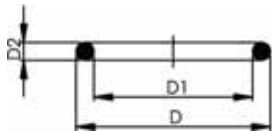

O-Ring Gaskets

Model:

- For unions and adaptor unions
- Hardness approx. 65° Shore
- EPDM minimum temperature -40°C
- FPM minimum temperature -15°C

* for unions PVC-U, PVC-C and ABS: 21 51 01, 21 51 11, 21 53 03, 21 53 08, 21 55 04, 21 55 13, 21 55 18, 23 51 01 and 29 51 01 only

d [mm]	DN [mm]	EPDM Code	FPM Code	kg	kg/m	D [mm]	D1 [mm]	D2 [mm]
10 - 12	8	748 410 004	749 410 004	0.001	0.001	18	12	2.62
16	10	748 410 005	749 410 005	0.001	0.001	21	16	2.62
20	15	748 410 006	749 410 006	0.001	0.001	27	20	3.53
25	20	748 410 007	749 410 007	0.002	0.002	35	28	3.53
32	25	748 410 008	749 410 008	0.002	0.002	40	33	3.53
40	32	748 410 009	749 410 009	0.007	0.007	51	41	5.34
50	40	748 410 010	749 410 010	0.060	0.060	58	47	5.34
63	50	748 410 011	749 410 011	0.003	0.003	70	60	5.34
75	65	748 410 014	749 410 014	0.012	0.012	93	82	5.34
90	80	748 410 015	749 410 015	0.015	0.015	112	101	5.34
* 90	80	748 410 248	749 410 248	0.020	0.020	105	95	5.34
110	100	748 410 016	749 410 016	0.031	0.031	134	120	6.99

Flange Adaptors, Flanges and Gaskets for Socket Fusion

53 79 02



Flange adaptor PE100 Jointing face flat/serrated

Model:

- Counterpart: Flange Adaptor flat/serrated or with O-ring groove
- Connection: according to EN ISO 15494-, DIN 16963-11
- Gasket: Profile flange gasket EPDM No. 48 44 07, FPM No. 49 44 07
- Flanges: PP with steel core, No. 27 70 02, PP-V, No 27 70 04

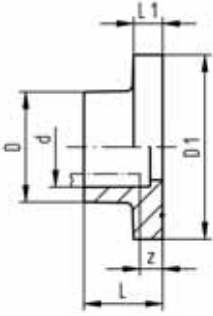

d [mm]	DN [mm]	PN	Code	kg	kg/m	D [mm]	D1 [mm]	L [mm]	L1 [mm]	z [mm]
20	15	10	753 790 206	0.013	0.013	27	45	19	7	5
25	20	10	753 790 207	0.022	0.022	33	58	21	9	5
32	25	10	753 790 208	0.035	0.035	41	68	23	10	5
40	32	10	753 790 209	0.052	0.052	50	78	25	11	5
50	40	10	753 790 210	0.061	0.061	61	88	28	12	5
63	50	10	753 790 211	0.095	0.095	76	102	32	14	5
75	65	10	753 790 212	0.163	0.163	90	122	36	16	5
90	80	10	753 790 213	0.203	0.203	108	138	42	17	7
110	100	10	753 790 214	0.293	0.293	131	158	48	18	7

33 81 01



Flange adaptor PE80 Jointing face with o-ring groove

Model:

- Counterpart: Flange adaptor flat/serrated 53 79 02
- Gasket: O-Ring EPDM No. 48 41 00
- Flanges: PP with steel core, No. 27 70 02, PP-V, No 27 70 04

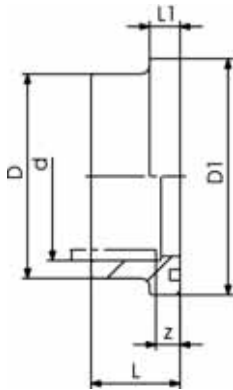

d [mm]	DN [mm]	PN	Code	kg	kg/m	D [mm]	D1 [mm]	L [mm]	L1 [mm]	z [mm]
20	15	10	733 810 106	0.008	0.008	27	34	22	9	8
25	20	10	733 810 107	0.012	0.012	33	41	24	10	8
32	25	10	733 810 108	0.019	0.019	41	50	26	10	8
40	32	10	733 810 109	0.031	0.031	50	61	30	13	10
50	40	10	733 810 110	0.044	0.044	61	73	33	13	10
63	50	10	733 810 111	0.072	0.072	76	90	37	14	10
75	65	10	733 810 112	0.112	0.112	90	106	40	15	10
90	80	10	733 810 113	0.185	0.185	108	125	47	16	12
110	100	10	733 810 114	0.285	0.285	131	150	55	18	13

53 70 06



Blanking flange set PE Combined jointing face flat and serrated metric

Model:

- d63 - d315: Backing Flange PP-V with End Blank PE
- d355 - d630: Backing Flange PP/Steel with End Blank PE
- Connecting dimensions: ISO 7005, EN 1092, DIN 2501
- **Bolt circle PN 10**

AL: number of holes

L: length of the End Blank

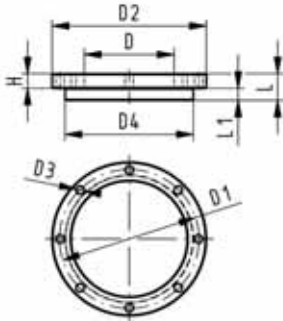

d [mm]	DN [mm]	PN	Code	kg	kg/m
63	50	16	753 700 611	0.674	0.674
75	65	16	753 700 612	0.910	0.910
90	80	16	753 700 613	0.921	0.921
110	100	16	753 700 614	1.158	1.158
125	100	16	753 700 615	1.678	1.678
140	125	16	753 700 616	1.913	1.913
160	150	16	753 700 617	2.373	2.373
180	150	16	753 700 618	2.430	2.430
200	200	16	753 700 619	3.495	3.495
225	200	16	753 700 620	3.744	3.744
250	250	16	753 700 621	6.051	6.051
280	250	16	753 700 622	6.305	6.305
315	300	16	753 700 623	8.894	8.894
355	350	16	753 700 624	23.198	23.198
400	400	16	753 700 625	30.766	30.766
450	500	10	753 700 626	44.271	44.271
500	500	10	753 700 627	47.165	47.165
560	600	10	753 700 628	67.147	67.147
630	600	10	753 700 629	68.574	68.574

d [mm]	D [mm]	D1 [mm]	D2 [mm]	D3 [mm]	D4 [mm]	H [mm]	L [mm]	L1 [mm]	AL
63	75	125	165	18	102	24	30	14	4
75	89	145	185	18	122	26	30	16	4
90	105	160	200	18	138	27	30	17	8
110	125	180	220	18	158	28	30	18	8
125	132	180	220	18	158	28	35	25	8
140	155	210	250	18	188	30	40	25	8
160	175	240	285	22	212	32	40	25	8
180	180	240	285	22	212	32	45	30	8
200	232	295	340	22	268	34	50	32	8
225	235	295	340	22	268	34	50	32	8
250	285	350	395	22	320	38	55	35	12
280	291	350	395	22	320	38	60	35	12
315	335	400	445	22	370	42	65	35	12
355	373	460	515	22	430	40	70	40	16
400	427	515	574	26	482	40	75	46	16
450	510	620	684	26	585	49	80	60	20
500	530	620	684	26	585	49	90	60	20
560	615	725	796	30	685	58	100	60	20
630	642	725	796	30	685	68	110	60	20

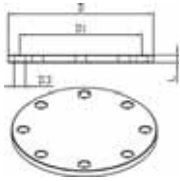

Blanking Flanges PE100

Model:

- made out of sheet material
- **Bolt circle PN 10**

d [mm]	DN [mm]	PN	Code	L [mm]	D [mm]	D1 [mm]	D3 [mm]	AL
63	50	2,5	700 647 886	15	165	125	18	4
75	65	2,5	700 647 887	15	185	145	18	4
90	80	2,5	700 647 888	15	200	160	18	8
110	100	2,5	700 647 889	15	220	180	18	8
125	100	2,5	700 647 890	15	220	180	18	8
140	125	2,5	700 647 891	15	250	210	18	8
160	150	2,5	700 647 892	20	285	240	22	8
180	150	2,5	700 647 893	25	285	240	22	8
200	200	2,5	700 647 894	25	340	295	22	8
225	200	2,5	700 647 895	30	340	295	22	8
250	250	2,5	700 647 896	30	395	350	22	12
280	250	2,5	700 647 897	30	395	350	22	12
315	300	2,5	700 647 898	40	445	400	22	12
355	350	2,5	700 647 899	40	515	460	22	16
400	400	2,5	700 647 900	45	574	515	26	16
450	500	2,5	700 647 901	55	670	620	26	20
500	500	2,5	700 647 902	60	670	620	26	20
560	600	2,5	700 647 903	65	780	725	30	20
630	600	2,5	700 647 904	75	780	725	30	20

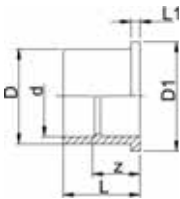

Outlet flange adaptor PE80 Jointing face flat

Model:

- With fusion socket metric
- Suitable for wafer check valves Type 369
- To be installed on the outlet side of the valve
- Use flanges PP-V 27 70 04

d [mm]	DN [mm]	PN	Code	kg	kg/m	D [mm]	D1 [mm]	L [mm]	L1 [mm]	z [mm]
40	32	6	733 800 009	0.065	0.065	50	78	55	11	35
50	40	6	733 800 010	0.088	0.088	61	88	61	12	38
63	50	6	733 800 011	0.136	0.136	76	102	69	14	41
75	65	6	733 800 012	0.223	0.223	90	122	79	16	49
90	80	6	733 800 013	0.357	0.357	107	138	100	17	65
110	100	6	733 800 014	0.482	0.482	130	158	105	18	62

27 70 04
27 70 05

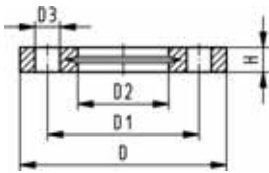

Backing Flanges, PP-V For socket systems metric

Model:

- Modern full-plastic flange PP-GF (30 % glass-fibre reinforced)
- With V-groove which applies force evenly on collar
- With integrated bolt retainers as an assembly aid
- UV-resistant. Applicable for outside applications
- Connecting dimension: ISO 7005, EN 1092, BS 4504, DIN 2501
- **Bolt circle PN 10**

* Combined version, metric-ANSI

AL: number of holes

1) Suitable for socket- and butt fusion systems (no pictograph on flange)

d [mm]	DN [mm]	PN	Code	kg	D [mm]	D1 [mm]	D2 [mm]	D3 [mm]	H [mm]	AL	SC
1) 20	15	16	727 700 406	0.093	95	65.0	28	14	16	4	M12
1) 25	20	16	727 700 407	0.120	105	75.0	34	14	17	4	M12
1) 32	25	16	727 700 408	0.151	115	85.0	42	14	18	4	M12
1) 40	32	16	727 700 409	0.244	140	100.0	51	18	20	4	M16
1) 50	40	16	727 700 410	0.297	150	110.0	62	18	22	4	M16
1) 63	50	16	727 700 411	0.362	165	125.0	78	18	24	4	M16
1) 75	65	16	727 700 412	0.487	185	145.0	92	18	26	4	M16
90	80	16	727 700 413	0.550	200	160.0	110	18	27	8	M16
110	100	16	727 700 414	0.640	220	180.0	133	18	28	8	M16

27 70 14
27 70 15

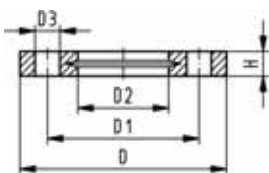

Backing Flanges, PP-V For socket systems Inch ANSI

Model:

- Modern full-plastic flange PP-GF (30 % glass-fibre reinforced)
- With V-groove which applies force evenly on collar
- With integrated bolt-fixing as an assembly aid
- UV-resistant. Applicable for outside applications
- Connecting dimension: ANSI/ASME B 16.5 class 150, ASTM D 4024, BS 1560, BS EN 1759
- **Bolt circle class 150**
- 727701414, 727700417, 727700419: only for use with original metric flange adaptors

1) Suitable for socket- and butt fusion systems (no pictograph on flange)

AL: number of holes

* Combined version, metric-ANSI

Inch	DN [mm]	d [mm]	PN	Code	kg	kg/m
1/2	15	20	16	727 701 406	0.091	0.091
3/4	20	25	16	727 701 407	0.120	0.120
1	25	32	16	727 701 408	0.147	0.147
1 1/4	32	40	16	727 701 409	0.246	0.246
1 1/2	40	50	16	727 701 410	0.299	0.299
2	50	63	16	727 701 411	0.361	0.361
2 1/2	65	75	16	727 701 412	0.492	0.492
3	80	90	16	727 701 413	0.605	0.605
4	100	110	16	727 701 414	0.704	0.704

Inch	D [mm]	D1 [mm]	D2 [mm]	D3 [mm]	H [mm]	AL	SC
1/2	95	60.0	28	16	16	4	M12
3/4	105	70.0	34	16	17	4	M12
1	115	79.0	42	16	18	4	M12
1 1/4	140	89.0	51	16	20	4	M16
1 1/2	150	98.0	62	16	22	4	M16
2	165	121.0	78	19	24	4	M16
2 1/2	185	140.0	92	19	26	4	M16
3	200	152.0	110	19	27	4	M16
4	229	190.0	133	19	28	8	M16

27 70 02

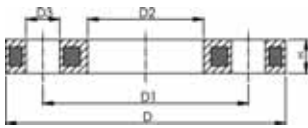

Backing flange PP-Steel For socket systems metric

Model:

- PP-GF (30% glass-fibre reinforced) with steel ring
- UV-resistant. Applicable for outside applications
- Connecting dimension: ISO 7005, EN 1092, BS 4504, DIN 2501
- **Bolt circle PN 10**

¹ Connecting dimension: ISO 2536, bolt circle acc. DN125, suitable for flange adaptor d125/DN100

² Connecting dimension: ISO 2536, bolt circle acc. DN225, suitable for flange adaptor d250/DN250

AL: number of holes

d [mm]	DN [mm]	PN	Code	kg	D [mm]	D1 [mm]	D2 [mm]	D3 [mm]	H [mm]	AL	SC
20	15	16	727 700 206	0.216	95	65	28	14	12	4	M12
25	20	16	727 700 207	0.279	105	75	34	14	12	4	M12
32	25	16	727 700 208	0.429	115	85	42	14	16	4	M12
40	32	16	727 700 209	0.621	140	100	51	18	16	4	M16
50	40	16	727 700 210	0.722	150	110	62	18	20	4	M16
63	50	16	727 700 211	1.084	165	125	78	18	20	4	M16
75	65	16	727 700 212	1.349	185	145	92	18	20	4	M16
90	80	16	727 700 213	1.369	200	160	110	18	20	8	M16
110	100	16	727 700 214	1.522	220	180	133	18	20	8	M16

27 70 12

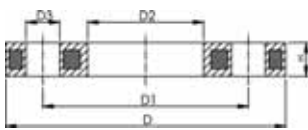

Backing Flanges, PP/Steel For socket systems Inch/ANSI

Model:

- For Flange Adaptors BS/ANSI
- Material: PP (30 % glass-fibre reinforced) with steel ring
- UV-resistant. Applicable for outside applications
- Connecting dimension: ANSI/ASME B 16.5 class 150, ASTM D 4024, BS 1560, BS EN 1759
- **Bolt circle class 150**
- 727701214, 727700217: only for use with original metric flange adaptors

AL: number of holes

d [inch]	DN [mm]	d [mm]	PN	Code	kg	kg/m	D1 [mm]	D2 [mm]	D3 [mm]	D [mm]	H [mm]	AL	SC
½	15	20	16	727 701 206	0.213	0.213	60	28	16	95	12	4	M12
¾	20	25	16	727 701 207	0.260	0.260	70	34	16	105	12	4	M12
1	25	32	16	727 701 208	0.416	0.416	79	42	16	115	16	4	M12
1 ¼	32	40	16	727 701 209	0.730	0.730	89	51	16	140	16	4	M16
1 ½	40	50	16	727 701 210	0.809	0.809	98	62	16	150	18	4	M16
2	50	63	16	727 701 211	0.866	0.866	121	78	19	165	18	4	M16
2 ½	65	75	16	727 701 212	1.117	1.117	140	92	19	185	18	4	M16
3	80	90	16	727 701 213	1.492	1.492	152	110	19	200	20	4	M16
4	100	110	16	727 701 214	1.695	1.695	190	133	19	229	20	8	M16

EPDM 48 41 01
FPM 49 41 01

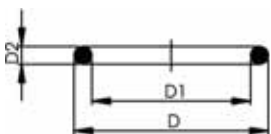

O-Ring Gaskets

Model:

- For Flange Adaptors
- Hardness approx. 65° Shore

d [mm]	DN [mm]	EPDM Code	FPM Code	kg	kg/m	D [mm]	D1 [mm]	D2 [mm]
20	15	748 410 001	749 410 001	0.002	0.002	31	23	3.53
25	20	748 410 007	749 410 007	0.002	0.002	35	28	3.53
32	25	748 410 002	749 410 002	0.003	0.003	43	36	3.53
40	32	748 410 003	749 410 003	0.001	0.001	55	44	5.34
50	40	748 410 012	749 410 012	0.008	0.008	64	53	5.34
63	50	748 410 013	749 410 013	0.011	0.011	80	69	5.34

table continued next page

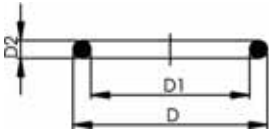

d [mm]	DN [mm]	EPDM Code	FPM Code	kg	kg/m	D [mm]	D1 [mm]	D2 [mm]	
75	65	748 410 014	749 410 014	0.012	0.012	93	82	5.34	
90	80	748 410 015	749 410 015	0.015	0.015	112	101	5.34	
110	100	748 410 016	749 410 016	0.031	0.031	134	120	6.99	

Fittings for Butt Fusion

53 01 87

Bend 90° PE100 SDR11

Model:

- Conventional butt-welding according to DVS 2207 part 1
- IR = Infrared-(IR Plus®) compatible. Choose fusion parameters: PE100

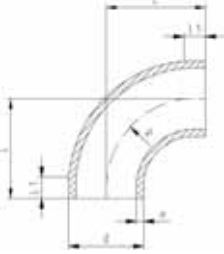

d [mm]	FM	Code	kg	L [mm]	L1 [mm]	R [mm]	e [mm]	PF
20	IR	753 018 706	0.007	38	23	15	1.9	2 68 240 006
25	IR	753 018 707	0.013	42	23	19	2.3	2 68 240 006
32	IR	753 018 708	0.025	46	22	24	2.9	2 68 240 006
40	IR	753 018 709	0.041	51	21	30	3.7	2 68 240 006
50	IR	753 018 710	0.065	58	21	37	4.6	2 68 240 006
63	IR	753 018 711	0.124	66	21	45	5.8	2 68 240 006
75	IR	753 018 712	0.246	100	20	90	6.8	2 68 240 006
90	IR	753 018 713	0.355	100	20	90	8.2	2 68 240 006
110	IR	753 018 714	0.757	141	25	130	10.0	2 68 240 006
125	IR	753 018 690	1.014	140	15	125	11.4	2 68 240 002
140	IR	753 018 691	1.383	155	15	140	12.7	2 68 240 002
160	IR	753 018 692	1.991	175	15	160	14.6	2 68 240 002
180	IR	753 018 693	2.876	195	15	180	16.4	2 68 240 002
200	IR	753 018 694	3.882	215	15	200	18.2	2 68 240 002
225	IR	753 018 695	5.587	245	20	225	20.5	2 68 240 002
250	--	753 018 621	6.713	256	48	232	22.7	2 68 240 002
280	--	753 018 622	9.885	286	48	262	25.4	2 68 240 002
315	--	753 018 623	14.158	321	48	297	28.6	2 68 240 002
355	--	753 021 024	17.200	380	38	355	32.3	2 68 240 040
400	--	753 021 025	31.100	434	41	400	36.3	2 68 240 040
450	--	753 021 026	38.300	445	49	450	40.9	2 68 240 040
500	--	753 021 027	47.300	450	49	500	45.5	2 68 240 040

Bend 90° PE100 SDR17/17.6

Model:

- Conventional butt-welding according to DVS 2207 part 1
- IR = Infrared-(IR Plus®) compatible. Choose fusion parameters: PE100

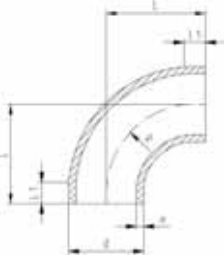

d [mm]	FM	Code	kg	L [mm]	L1 [mm]	R [mm]	e [mm]	PF
50	IR	753 018 635	0.052	58	21	37	2.9	2 68 240 026
63	IR	753 018 636	0.087	66	21	45	3.6	2 68 240 026
75	IR	753 018 737	0.176	100	20	90	4.3	2 68 240 026
90	IR	753 018 738	0.245	100	20	90	5.1	2 68 240 026
110	IR	753 018 739	0.513	141	20	130	6.3	2 68 240 026
125	IR	753 018 590	0.692	140	15	125	7.1	2 68 240 022
140	IR	753 018 591	0.904	155	15	140	8.0	2 68 240 022
160	IR	753 018 592	1.350	175	15	160	9.1	2 68 240 022
180	IR	753 018 593	1.935	195	15	180	10.2	2 68 240 022
200	IR	753 018 594	2.578	215	15	200	11.4	2 68 240 022
225	IR	753 018 595	3.542	245	15	225	12.8	2 68 240 022
250	--	753 018 521	4.645	256	48	232	14.2	2 68 240 002
280	--	753 018 522	7.020	286	48	262	15.9	2 68 240 002
315	--	753 018 523	10.099	321	48	297	17.9	2 68 240 002
355	--	753 020 824	11.300	340	38	355	21.1	2 68 240 040
400	--	753 020 825	15.700	345	41	400	23.7	2 68 240 040
450	--	753 020 826	25.868	449	49	450	25.8	2 68 240 040
500	--	753 020 827	35.000	449	49	500	32.0	2 68 240 040

53 10 86

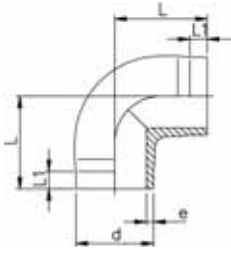
Elbow 90° PE100 SDR11**Model:**

- Conventional butt-welding according to DVS 2207 part 1
- IR = Infrared-(IR Plus®) compatible. Choose fusion parameters: PE100

d [mm]	FM	Code	kg	L [mm]	L1 [mm]	e [mm]	
20	IR	753 108 606	0.009	38	25	1,9	
25	IR	753 108 607	0.013	42	26	2,3	
32	IR	753 108 608	0.026	46	27	2,9	
40	IR	753 108 609	0.047	51	22	3,7	
50	IR	753 108 610	0.086	58	23	4,6	
63	IR	753 108 611	0.150	66	21	5,8	

53 15 86

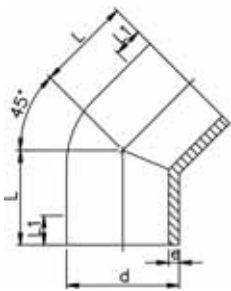
Elbow 45° PE100 SDR11**Model:**

- Conventional butt-welding according to DVS 2207 part 1
- IR = Infrared-(IR Plus®) compatible. Choose fusion parameters: PE100

d [mm]	FM	Code	kg	L [mm]	L1 [mm]	e [mm]	PF
20	IR	753 158 606	0.007	32	24	1,9	2 68 240 008
25	IR	753 158 607	0.013	34	25	2,3	2 68 240 008
32	IR	753 158 608	0.019	36	25	2,9	2 68 240 008
40	IR	753 158 609	0.036	39	25	3,7	2 68 240 008
50	IR	753 158 610	0.059	42	26	4,6	2 68 240 008
63	IR	753 158 611	0.103	47	29	5,8	2 68 240 008
75	IR	753 158 612	0.146	49	29	6,8	2 68 240 008
90	IR	753 158 613	0.241	57	34	8,2	2 68 240 008
110	IR	753 158 614	0.442	70	43	10,0	2 68 240 008
125	IR	753 158 615	0.638	79	48	11,4	2 68 240 003
140	IR	753 158 616	0.902	88	55	12,7	2 68 240 003
160	IR	753 158 617	1.340	100	60	14,6	2 68 240 003
200	IR	753 158 619	2.612	124	75	18,2	2 68 240 003
225	IR	753 158 620	3.638	140	85	20,5	2 68 240 003

53 15 85

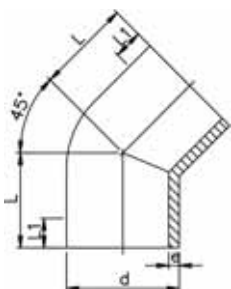
Elbow 45° PE100 SDR17.6**Model:**

- Conventional butt-welding according to DVS 2207 part 1
- IR = Infrared-(IR Plus®) compatible. Choose fusion parameters: PE100

d [mm]	FM	Code	kg	L [mm]	L1 [mm]	e [mm]	PF
50	IR	753 158 535	0.045	42	26	2,9	2 68 240 008
63	IR	753 158 536	0.091	47	29	3,6	2 68 240 008
75	IR	753 158 412	0.125	49	29	4,7	2 68 240 008
90	IR	753 158 413	0.198	57	34	5,6	2 68 240 028
110	IR	753 158 414	0.375	70	43	6,9	2 68 240 028
125	IR	753 158 540	0.542	79	48	7,1	2 68 240 028
140	IR	753 158 541	0.784	88	55	8,0	2 68 240 023
160	IR	753 158 542	1.190	100	60	9,1	2 68 240 023
200	IR	753 158 544	2.331	124	75	11,4	2 68 240 023
225	IR	753 158 545	3.282	140	85	12,8	2 68 240 023

53 20 86

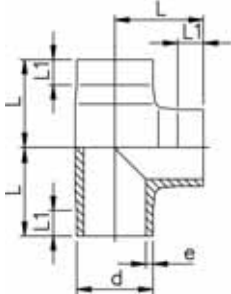
Tee 90° equal PE100 SDR11**Model:**

- Conventional butt-welding according to DVS 2207 part 1
- IR = Infrared-(IR Plus®) compatible. Choose fusion parameters: PE100

d [mm]	FM	Code	kg	L [mm]	L1 [mm]	e [mm]
20	IR	753 208 606	0.013	38	24	1,9
25	IR	753 208 607	0.021	42	26	2,3
32	IR	753 208 608	0.042	46	26	2,9
40	IR	753 208 609	0.065	51	22	3,7
50	IR	753 208 610	0.111	58	22	4,6
63	IR	753 208 611	0.202	66	21	5,8
75	IR	753 208 612	0.312	75	20	6,8
90	IR	753 208 613	0.553	90	20	8,2
110	IR	753 208 614	1.002	110	20	10,0
125	IR	753 208 615	1.509	125	25	11,4
140	IR	753 208 616	2.105	140	28	12,7
160	IR	753 208 617	3.085	160	28	14,6
180	IR	753 208 668	5.062	190	70	16,4
200	IR	753 208 619	5.982	200	35	18,2
225	IR	753 208 620	8.090	220	35	20,5
250	--	753 208 671	13.326	272	90	22,7
280	--	753 208 672	20.458	313	108	25,4
315	--	753 208 673	27.400	348	114	28,6
355	--	753 221 024	30.500	352	97	32,3
400	--	753 221 025	39.000	337	100	36,4
450	--	753 221 026	45.000	450	130	40,9
500	--	753 221 027	75.500	450	130	45,5

53 20 86

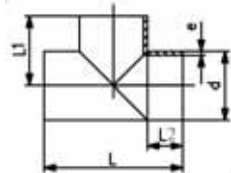
Tee 90° equal PE100 SDR11**Model:**

- Conventional butt-welding according to DVS 2207 part 1
- Machined
- 10 bar Gas / 16 bar Water

* on request

d [mm]	Code	kg	L [mm]	L1 [mm]	z [mm]	e [mm]
560	753 211 028		780	500	80	50.8
630	753 211 029		850	540	80	57.2
710	753 211 030	177.442	950	650	75	64.5
* 800	753 211 031	233.384	1013	700	75	72.6

53 20 85

Tee 90° equal PE100 SDR17/17.6**Model:**

- Conventional butt-welding according to DVS 2207 part 1
- IR = Infrared-(IR Plus®) compatible. Choose fusion parameters: PE100

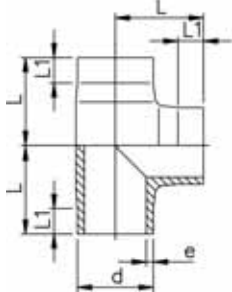

d [mm]	FM	Code	kg	L [mm]	L1 [mm]	e [mm]	PF
50	IR	753 208 535	0.080	59	26	2,9	2 68 240 021
63	IR	753 208 536	0.187	71	25	3,6	2 68 240 021
75	IR	753 208 412	0.232	74	20	4,8	2 68 240 021
90	IR	753 208 413	0.408	90	20	5,6	2 68 240 021
110	IR	753 208 414	0.724	110	20	6,9	2 68 240 021
125	IR	753 208 540	1.175	124	27	7,1	2 68 240 029
140	IR	753 208 541	1.623	141	33	8,0	2 68 240 029
160	IR	753 208 542	2.431	160	40	9,1	2 68 240 029
180	IR	753 208 543	3.756	190	70	10,2	2 68 240 029
200	IR	753 208 544	5.243	210	70	11,4	2 68 240 029
225	IR	753 208 545	1.872	238	80	12,8	2 68 240 029
250	--	753 208 546	9.964	272	90	14,2	2 68 240 029
280	--	753 208 547	14.265	313	108	15,9	2 68 240 029
315	--	753 208 548	22.284	348	114	17,9	2 68 240 029
355	--	753 220 824	22.593	330	95	21,1	2 68 240 040
400	--	753 220 825	30.500	345	104	23,7	2 68 240 040
450	--	753 220 826	38.000	450	130	26,7	2 68 240 040
500	--	753 220 827	52.600	445	130	29,7	2 68 240 040

53 20 85

Tee 90° equal PE100 SDR17/17.6**Model:**

- Conventional butt-welding according to DVS 2207 part 1
- Machined
- 5 bar Gas / 10 bar Water

* on request

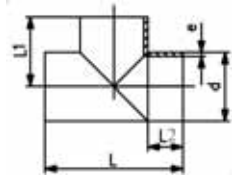

d [mm]	Code	kg	L [mm]	L1 [mm]	L2 [mm]	e [mm]
560	753 220 831	153.300	780	500	80	33.2
630	753 208 832	205.500	850	540	80	37.4
710	753 220 833	121.141	950	650	75	42.1
* 800	753 220 834	158.977	1013	700	75	47.4

Tee 90° equal PE100 S5/SDR11

- For IR, butt- and electro fusion
- Reducing factor = 0,6

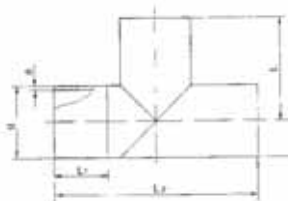

d [mm]	Code	kg	L [mm]	L1 [mm]	L2 [mm]	e [mm]
110	700 649 056	2.230	205	150	410	10,0
125	700 649 057	2.400	215	150	430	11,4
140	700 649 058	3.100	220	150	440	12,8
160	700 649 059	4.150	230	150	460	14,6
180	700 649 060	5.320	240	150	480	16,4
200	700 649 061	6.810	250	150	500	18,2
225	700 649 062	8.960	265	150	530	20,5
250	700 649 063	16.200	375	250	750	22,8
280	700 649 064	20.950	390	250	780	25,5
315	700 649 065	31.540	460	300	920	28,7
355	700 649 066	41.250	480	300	960	32,3
400	700 649 067	5.380	500	1000	1000	36,4
450	700 649 068	70.400	525	1050	1050	41,0
500	700 649 069	98.380	600	1200	1200	45,5
560	700 649 070	131.830	630	1260	1260	51,0
630	700 649 071	172.600	665	1330	1330	57,3

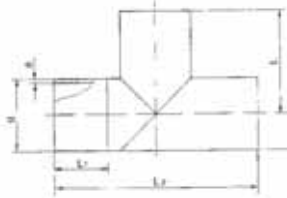

Tee 90° equal PE100 S8/SDR17.6

- For IR, butt- and electro fusion
- Reducing factor = 0,6

d [mm]	Code	kg	L [mm]	L1 [mm]	L2 [mm]	e [mm]
110	700 649 072	9.782	205	150	410	6,3
125	700 649 073	13.430	215	150	430	7,1
140	700 649 074	18.342	220	150	440	8,0
160	700 649 075	20.062	230	150	460	9,1
180	700 649 076	26.736	240	150	480	10,2
200	700 649 077	36.063	250	150	500	11,4
225	700 649 078	1.162	265	150	530	12,8
250	700 649 079	1.584	375	250	750	14,2
280	700 649 080	2.046	390	250	780	15,9
315	700 649 081	2.739	460	300	920	17,9
355	700 649 082	29.960	480	300	960	20,1
400	700 649 083	4.495	500	300	1000	22,7
450	700 649 084	55.340	525	300	1050	25,5
500	700 649 085	10.692	600	350	1200	28,3
560	700 649 086	13.827	630	350	1260	31,7
630	700 649 087	20.816	665	350	1330	35,7

53 20 83

Tee 90° reduced PE100 SDR11

Model:

- Conventional butt-welding according to DVS 2207 part 1
- IR = Infrared-(IR Plus®) compatible. Choose fusion parameters: PE100

d [mm]	d1 [mm]	FM	Code	kg	L [mm]	L1 [mm]	L2 [mm]	L3 [mm]	e [mm]	e1 [mm]	PF
63	32	IR	753 208 351	0.161	65	70	25	25	5,8	2,9	2 68 240 017
63	50	IR	753 208 352	0.180	65	70	25	25	5,8	4,6	2 68 240 017
75	32	IR	753 208 353	0.255	70	75	25	25	6,8	2,9	2 68 240 017
75	50	IR	753 208 354	0.265	70	75	25	25	6,8	4,6	2 68 240 017
75	63	IR	753 208 355	0.278	70	75	25	25	6,8	5,8	2 68 240 017
90	50	IR	753 208 357	0.435	80	85	25	25	8,2	4,6	2 68 240 017
90	63	IR	753 208 358	0.448	80	85	25	25	8,2	5,8	2 68 240 017
90	75	IR	753 208 359	0.462	80	85	25	25	8,2	6,8	2 68 240 017
110	32	IR	753 208 360	0.685	90	95	30	25	10,0	2,9	2 68 240 017
110	50	IR	753 208 361	0.694	90	95	30	25	10,0	4,6	2 68 240 017
110	63	IR	753 208 362	0.709	90	95	30	25	10,0	5,8	2 68 240 017
110	75	IR	753 208 363	0.717	90	95	30	25	10,0	6,8	2 68 240 017
110	90	IR	753 208 364	0.734	90	95	30	25	10,0	8,2	2 68 240 017
160	63	IR	753 208 371	2.269	142	135	50	30	14,6	5,8	2 68 240 017
160	75	IR	753 208 372	2.255	142	135	50	30	14,6	6,8	2 68 240 017
160	90	IR	753 208 373	2.317	142	135	50	30	14,6	8,2	2 68 240 017
160	110	IR	753 208 374	2.353	142	135	50	30	14,6	10,0	2 68 240 017
225	90	IR	753 208 388	4.759	155	165	40	30	20,5	8,2	2 68 240 017
225	110	IR	753 208 389	4.796	155	165	40	30	20,5	10,0	2 68 240 017
225	160	IR	753 208 391	4.854	155	165	40	30	20,5	14,6	2 68 240 017
3 250	110	--	753 221 031	8.199	228	197	140	37	22,7	10,0	2 68 240 040
3 250	160	--	753 221 032	8.564	229	219	117	60	22,7	14,6	2 68 240 040

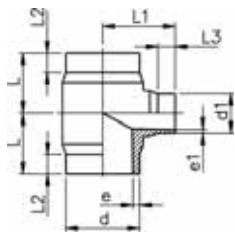



Tee 90° reduced PE100 SDR17.6

Model:

- Conventional butt-welding according to DVS 2207 part 1
- IR = Infrared-(IR Plus®) compatible. Choose fusion parameters: PE100
- 5 bar Gas / 10 bar Water

* Branch SDR11

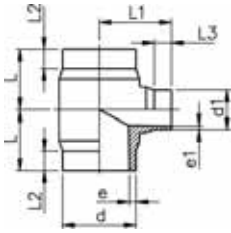

d	d1	FM	Code	kg	L	L1	L2	L3	e	e1
[mm]	[mm]				[mm]	[mm]	[mm]	[mm]	[mm]	[mm]
* 63	32	IR	753 208 301	0.163	65	70	25	25	3,6	2,9
63	50	IR	753 208 302	0.171	65	70	25	25	3,6	2,9
* 75	32	IR	753 208 303	0.231	70	75	25	25	4,3	2,9
75	50	IR	753 208 304	0.250	70	75	25	25	4,3	2,9
75	63	IR	753 208 305	0.263	70	75	25	25	4,3	3,6
90	50	IR	753 208 307	0.411	80	85	25	25	5,1	2,9
90	63	IR	753 208 308	0.329	80	85	25	25	5,1	3,6
90	75	IR	753 208 309	0.339	80	85	25	25	5,1	4,3
* 110	32	IR	753 208 310	0.643	90	95	30	25	6,3	2,9
110	50	IR	753 208 311	0.655	90	95	30	25	6,3	2,9
110	63	IR	753 208 312	0.516	90	95	30	25	6,3	3,6
110	75	IR	753 208 313	0.521	90	95	30	25	6,3	4,3
110	90	IR	753 208 314	0.529	90	95	30	25	6,3	5,1
160	63	IR	753 208 321	2.103	142	135	50	30	9,1	3,6
160	75	IR	753 208 322	2.142	142	135	50	30	9,1	4,3
160	90	IR	753 208 323	1.668	142	135	50	30	9,1	5,1
160	110	IR	753 208 324	1.687	142	135	50	30	9,1	6,3
225	90	IR	753 208 338	3.439	155	165	40	30	12,8	5,1
225	110	IR	753 208 339	3.448	155	165	40	30	12,8	6,3
225	160	IR	753 208 341	3.471	155	165	40	30	12,8	9,1

Tee 90° reduced PE100 S5/SDR11

- For IR, butt- and electro fusion
- Reducing factor = 0,6

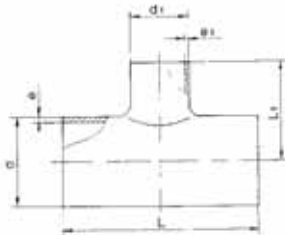

d	d1	Code	kg	L	L1	e	e1
[mm]	[mm]			[mm]	[mm]	[mm]	[mm]
225	63	700 649 155	35.500	363	238	20,5	5,8
225	75	700 649 156	35.855	375	238	20,5	6,9
225	90	700 649 157	36.214	390	238	20,5	8,2
225	110	700 649 158	36.576	410	238	20,5	10,0
225	125	700 649 159	36.941	425	238	20,5	11,4
225	140	700 649 160	37.311	440	238	20,5	12,8
225	160	700 649 161	37.684	460	238	20,5	14,6
250	75	700 649 162	38.061	475	250	22,8	6,9
250	90	700 649 163	38.441	490	250	22,8	8,2
250	110	700 649 164	38.826	510	250	22,8	10,0
250	125	700 649 165	39.214	525	250	22,8	11,4
250	140	700 649 166	39.606	540	1000	22,8	12,8
250	160	700 649 167	40.002	560	1050	22,8	14,6
250	180	700 649 168	40.402	580	275	22,8	16,4
280	75	700 649 169	40.806	475	265	25,5	6,9
280	90	700 649 170	6.650	490	265	25,5	8,2
280	110	700 649 171	41.627	510	265	25,5	10,0
280	125	700 649 172	42.043	525	265	25,5	11,4
280	140	700 649 173	42.463	540	265	25,5	12,8
280	160	700 649 174	42.888	560	265	25,5	14,6
280	180	700 649 175	43.317	580	290	25,5	16,4
280	200	700 649 176	43.750	600	290	25,5	18,2
315	90	700 649 177	44.187	490	283	28,7	8,2
315	110	700 649 178	44.629	510	283	28,7	10,0
315	125	700 649 179	45.076	525	283	28,7	11,4
315	140	700 649 180	45.526	540	283	28,7	12,8
315	160	700 649 181	7.580	560	283	28,7	14,6
315	180	700 649 182	46.441	580	308	28,7	16,4
315	200	700 649 183	46.906	600	308	28,7	18,2
315	225	700 649 184	9.310	625	308	28,7	20,5
355	110	700 649 185	47.849	510	303	32,3	10,0

table continued next page

d [mm]	d1 [mm]	Code	kg	L [mm]	L1 [mm]	e [mm]	e1 [mm]
355	125	700 649 186	48.327	525	303	32,3	11,4
355	140	700 649 187	48.810	540	303	32,3	12,8
355	160	700 649 188	49.298	560	303	32,3	14,6
355	180	700 649 189	49.791	580	328	32,3	16,4
355	200	700 649 190	50.289	600	328	32,3	18,2
355	225	700 649 191	50.792	625	328	32,3	20,5
355	250	700 649 192	51.300	650	378	32,3	22,8
400	110	700 649 193	51.813	510	325	36,4	10,0
400	125	700 649 194	52.331	525	325	36,4	11,4
400	140	700 649 195	52.855	540	325	36,4	12,8
400	160	700 649 196	53.383	560	325	36,4	14,6
400	180	700 649 197	53.917	580	350	36,4	16,4
400	200	700 649 198	54.456	600	350	36,4	18,2
400	225	700 649 199	55.001	625	350	36,4	20,5
400	250	700 649 200	55.551	650	400	36,4	22,8
400	280	700 649 201	56.106	680	400	36,4	25,5
450	110	700 649 202	56.667	510	350	41,0	10,0
450	125	700 649 203	57.234	525	350	41,0	11,4
450	140	700 649 204	57.806	540	350	41,0	12,8
450	160	700 649 205	58.384	560	350	41,0	14,6
450	180	700 649 206	58.968	580	375	41,0	16,4
450	200	700 649 207	59.558	600	375	41,0	18,2
450	225	700 649 208	60.154	625	375	41,0	20,5
450	250	700 649 209	60.755	650	425	41,0	22,8
450	280	700 649 210	61.363	680	425	41,0	25,5
450	315	700 649 211	61.976	715	425	41,0	28,7
500	110	700 649 212	62.596	510	375	45,5	10,0
500	125	700 649 213	63.222	525	375	45,5	11,4
500	140	700 649 214	63.854	540	375	45,5	12,8
500	160	700 649 215	64.493	560	375	45,5	14,6
500	180	700 649 216	65.138	580	400	45,5	16,4
500	200	700 649 217	65.789	600	400	45,5	18,2
500	225	700 649 218	66.447	625	400	45,5	20,5
500	250	700 649 219	67.111	650	450	45,5	22,8
500	280	700 649 220	67.783	680	450	45,5	25,5
500	315	700 649 221	68.460	715	450	45,5	28,7

Tee 90° reduced PE100 S8/SDR17.6

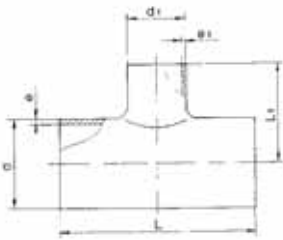

- For IR, butt- and electro fusion
- Reducing factor = 0,6

d [mm]	d1 [mm]	Code	kg	L [mm]	L1 [mm]	e [mm]	e1 [mm]
225	63	700 649 088	35.500	363	238	12,8	3,6
225	75	700 649 089	3.280	375	238	12,8	4,3
225	90	700 649 090	36.214	390	238	12,8	5,1
225	110	700 649 091	36.576	410	238	12,8	6,3
225	125	700 649 092	36.941	425	238	12,8	7,1
225	140	700 649 093	4.320	440	238	12,8	8,0
225	160	700 649 094	4.410	460	238	12,8	9,1
250	75	700 649 095	38.061	475	250	14,2	4,3
250	90	700 649 096	38.441	490	250	14,2	5,1
250	110	700 649 097	38.826	510	250	14,2	6,3
250	125	700 649 098	39.214	525	250	14,2	7,1
250	140	700 649 099	39.606	540	250	14,2	8,0
250	160	700 649 100	40.002	560	250	14,2	9,1
250	180	700 649 101	7.490	580	275	14,2	10,2
280	75	700 649 102	6.650	475	265	15,9	4,3
280	90	700 649 103	41.214	490	265	15,9	5,1
280	110	700 649 104	7.400	510	265	15,9	6,3
280	125	700 649 105	42.043	525	265	15,9	7,1
280	140	700 649 106	7.320	540	265	15,9	8,0
280	160	700 649 107	7.580	560	265	15,9	9,1
280	180	700 649 108	43.317	580	290	15,9	10,2
280	200	700 649 109	43.750	600	290	15,9	11,4
315	90	700 649 110	44.187	490	283	17,9	5,1

table continued next page

d [mm]	d1 [mm]	Code	kg	L [mm]	L1 [mm]	e [mm]	e1 [mm]
315	110	700 649 111	44.629	510	283	17,9	6,3
315	125	700 649 112	45.076	525	283	17,9	7,1
315	140	700 649 113	10.140	540	283	17,9	8,0
315	160	700 649 114	10.280	560	283	17,9	9,1
315	180	700 649 115	46.441	580	308	17,9	10,2
315	200	700 649 116	46.906	600	308	17,9	11,4
315	225	700 649 117	11.830	625	308	17,9	12,8
355	110	700 649 118	11.130	510	303	20,1	6,3
355	125	700 649 119	11.340	525	303	20,1	7,1
355	140	700 649 120	48.810	540	303	20,1	8,0
355	160	700 649 121	12.200	560	303	20,1	9,1
355	180	700 649 122	49.791	580	328	20,1	10,2
355	200	700 649 123	50.289	600	328	20,1	11,4
355	225	700 649 124	14.550	625	328	20,1	12,8
355	250	700 649 125	17.120	650	378	20,1	14,2
400	110	700 649 126	51.813	510	325	22,7	6,3
400	125	700 649 127	52.331	525	325	22,7	7,1
400	140	700 649 128	52.855	540	325	22,7	8,0
400	160	700 649 129	15.450	560	325	22,7	9,1
400	180	700 649 130	15.630	580	350	22,7	10,2
400	200	700 649 131	54.456	600	350	22,7	11,4
400	225	700 649 132	17.620	625	350	22,7	12,8
400	250	700 649 133	18.970	650	400	22,7	14,2
400	280	700 649 134	19.510	680	400	22,7	15,9
450	110	700 649 135	56.667	510	350	25,5	6,3
450	125	700 649 136	57.234	525	350	25,5	7,1
450	140	700 649 137	57.806	540	350	25,5	8,0
450	160	700 649 138	58.384	560	350	25,5	9,1
450	180	700 649 139	58.968	580	375	25,5	10,2
450	200	700 649 140	59.558	600	375	25,5	11,4
450	225	700 649 141	60.154	625	375	25,5	12,8
450	250	700 649 142	60.755	650	425	25,5	14,2
450	280	700 649 143	61.363	680	425	25,5	15,9
450	315	700 649 144	26.780	715	425	25,5	17,9
500	110	700 649 145	62.596	510	375	28,3	6,3
500	125	700 649 146	63.222	525	375	28,3	7,1
500	140	700 649 147	63.854	540	375	28,3	8,0
500	160	700 649 148	64.493	560	375	28,3	9,1
500	180	700 649 149	65.138	580	400	28,3	10,2
500	200	700 649 150	65.789	600	400	28,3	11,4
500	225	700 649 151	66.447	625	400	28,3	12,8
500	250	700 649 152	67.111	650	450	28,3	14,2
500	280	700 649 153	67.783	680	450	28,3	15,9
500	315	700 649 154	68.460	715	450	28,3	17,9

Branch 45° PE100 S5/SDR11

- For IR, butt- and electro fusion
- Reduction factor = 0,5

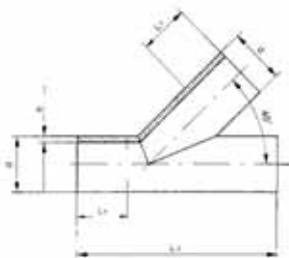

d [mm]	Code	kg	L1 [mm]	L2 [mm]	e [mm]
110	700 649 299	3.190	150	520	10,0
125	700 649 300	4.120	150	520	11,4
140	700 649 301	5.130	150	570	12,8
160	700 649 302	6.730	150	640	14,6
180	700 649 303	8.500	150	700	16,4
200	700 649 304	12.600	150	800	18,2
225	700 649 305	15.960	150	800	20,5
250	700 649 306	16.200	250	1000	22,8
280	700 649 307	20.950	250	1000	25,5
315	700 649 308	31.540	300	1300	28,7
355	700 649 309	41.250	300	1500	32,3
400	700 649 310	53.800	300	1500	36,4
450	700 649 311	70.400	300	1500	41,0

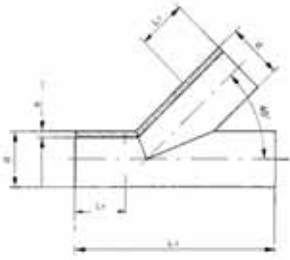

Branch 45° PE100 S8/SDR17.6

- For IR, butt- and electro fusion
- Reduction factor = 0,5

d [mm]	Code	kg	L1 [mm]	L2 [mm]	e [mm]
110	700 649 286	2.210	150	520	6,3
125	700 649 287	2.960	150	520	7,1
140	700 649 288	0.561	150	570	8,0
160	700 649 289	4.830	150	640	9,1
180	700 649 290	0.898	150	700	10,2
200	700 649 291	1.155	150	800	11,4
225	700 649 292	10.350	150	800	12,8
250	700 649 293	15.110	250	1000	14,2
280	700 649 294	3.115	250	1000	15,9
315	700 649 295	33.800	300	1300	17,9
355	700 649 296	4.851	300	1500	20,1
400	700 649 297	54.200	300	1500	22,7
450	700 649 298	46.464	300	1500	25,5

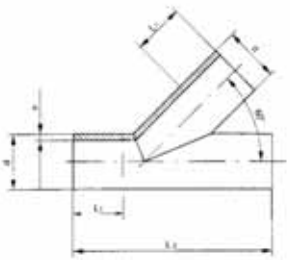

Branch 60° PE100 S5/SDR11

- For IR, butt- and electro fusion
- Reduction factor = 0,5

d [mm]	Code	kg	L1 [mm]	L2 [mm]	e [mm]
110	700 649 325	3.190	150	520	10,0
125	700 649 326	4.120	150	520	11,4
140	700 649 327	4.130	150	570	12,8
160	700 649 328	6.730	150	640	14,6
180	700 649 329	5.320	150	700	16,4
200	700 649 330	12.600	150	800	18,2
225	700 649 331	8.960	150	800	20,5
250	700 649 332	16.200	250	1000	22,8
280	700 649 333	20.950	250	1000	25,5
315	700 649 334	31.540	300	1300	28,7
355	700 649 335	41.250	300	1500	32,3
400	700 649 336	53.800	300	1500	36,4
450	700 649 337	70.400	300	1500	41,0

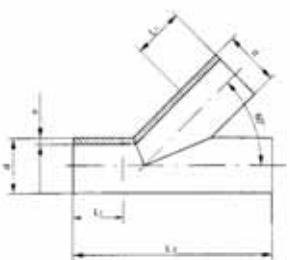

Branch 60° PE100 S8/SDR17.6

- For IR, butt- and electro fusion
- Reduction factor = 0,5

d [mm]	Code	kg	L1 [mm]	L2 [mm]	e [mm]
110	700 649 312	1.176	150	520	6,3
125	700 649 313	2.056	150	520	7,1
140	700 649 314	2.553	150	570	8,0
160	700 649 315	3.202	150	640	9,1
180	700 649 316	4.055	150	700	10,2
200	700 649 317	30.666	150	800	11,4
225	700 649 318	10.360	150	800	12,8
250	700 649 319	1.584	250	1000	14,2
280	700 649 320	2.046	250	1000	15,9
315	700 649 321	2.739	300	1300	17,9
355	700 649 322	3.511	300	1500	20,1
400	700 649 323	4.495	300	1500	22,7
450	700 649 324	5.914	300	1500	25,5

Revision Tees 90°, PE100 SDR11

Model:

- Flued and butt fusion according to DVS2207
- Backing Flanges to ISO 7005, EN 1092, DIN 2501, bolt circle PN 10
- Reducing factor = 0,6

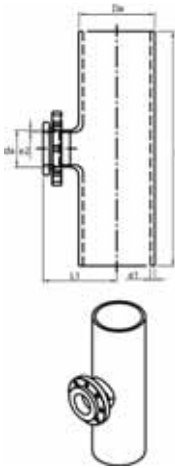

d [mm]	d1 [mm]	PN	Code	kg	L [mm]	L1 [mm]	e1 [mm]	e2 [mm]
110	110	16	700 665 656	1.000	500	236	10,0	10,0
125	125	16	700 665 657	1.000	500	248	11,4	11,4
140	140	16	700 665 658	1.000	500	265	12,7	12,7
160	110	16	700 665 659	1.000	500	278	14,6	10,0
180	110	16	700 665 660	1.000	500	350	16,4	10,0
200	140	16	700 665 661	1.000	500	350	18,2	12,7
225	140	16	700 665 662	1.000	560	400	20,5	12,7
250	160	16	700 665 663	1.000	750	450	22,7	14,6
280	225	16	700 665 664	1.000	750	350	25,4	20,5
315	225	16	700 665 665	1.000	850	400	28,6	20,5
355	225	16	700 665 666	1.000	950	450	32,2	20,5
400	225	16	700 665 667	1.000	1000	450	36,3	20,5

Revision Tees 90°, PE100 SDR17.6

Model:

- Flued and butt fusion according to DVS2207
- Backing Flanges to ISO 7005, EN 1092, DIN 2501, bolt circle PN 10
- Reducing factor = 0,6

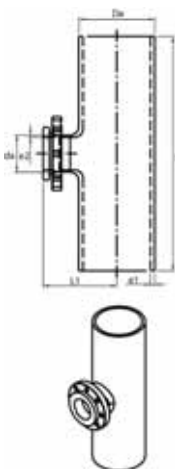

d [mm]	d1 [mm]	PN	Code	kg	L [mm]	L1 [mm]	e1 [mm]	e2 [mm]
110	110	10	700 665 668	1.000	500	236	6,3	6,3
125	125	10	700 665 669	1.000	500	248	7,1	7,1
140	140	10	700 665 670	1.000	500	265	8,0	8,0
160	110	10	700 665 671	1.000	500	278	9,1	6,3
180	110	10	700 665 672	1.000	500	350	10,2	6,3
200	140	10	700 665 673	1.000	500	350	11,4	8,0
225	140	10	700 665 674	1.000	560	400	12,8	8,0
250	160	10	700 665 675	1.000	750	450	14,2	9,1
280	225	10	700 665 676	1.000	750	350	15,9	12,8
315	225	10	700 665 677	1.000	850	400	17,9	12,8
355	225	10	700 665 678	1.000	950	450	20,1	12,8
400	225	10	700 665 679	1.000	1000	450	22,7	12,8
450	315	10	700 665 680	1.000	1100	500	25,5	17,9
500	315	10	700 665 681	1.000	1200	500	28,4	17,9
560	315	10	700 665 682	1.000	1300	550	31,7	17,9
630	315	10	700 665 683	1.000	1450	550	35,7	17,9

Saddle-tee PE100 S5/SDR11 Outlet with female thread Rp welded

- For IR, butt- and electro fusion
- Reduction factor = 0,8

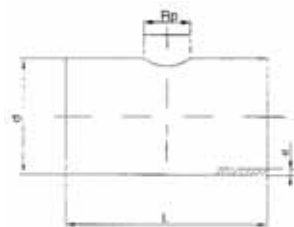

d [mm]	Thread 1" Code	Thread 11/4" Code	kg	L [mm]	e [mm]
110	700 649 238	700 649 270	0.850	260	10,0
125	700 649 239	700 649 271	1.100	260	11,4
140	700 649 240	700 649 272	1.360	260	12,8
160	700 649 241	700 649 273	1.750	260	14,6
180	700 649 242	700 649 274	2.200	360	16,4
200	700 649 243	700 649 275	2.700	360	18,2
225	700 649 244	700 649 276	4.720	360	20,5
250	700 649 245	700 649 277	5.860	360	22,8
280	700 649 246	700 649 278	7.350	360	25,5
315	700 649 247	700 649 279	9.310	360	28,7
355	700 649 248	700 649 280	13.200	460	32,3
400	700 649 249	700 649 281	19.120	460	36,4
450	700 649 250	700 649 282	24.200	460	41,0

table continued next page

d [mm]	Thread 1" Code	Thread 1 1/4" Code	kg	L [mm]	e [mm]
500	700 649 251	700 649 283	29.850	460	45,5
560	700 649 252	700 649 284	31.250	460	51,0
630	700 649 253	700 649 285	43.250	500	57,3

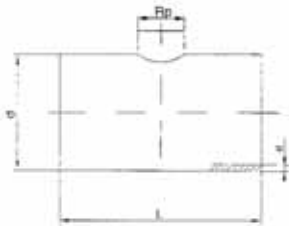

Saddle-tee PE100 S8/SDR17.6 Outlet with female thread Rp welded

- For IR, butt- and electro fusion
- Reduction factor = 0,8

d [mm]	Thread 1" Code	Thread 1 1/4" Code	kg	L [mm]	e [mm]
110	700 649 222	700 649 254	0.560	260	6,3
125	700 649 223	700 649 255	30.666	260	7,1
140	700 649 224	700 649 256	1.162	260	8,0
160	700 649 225	700 649 257	1.584	260	9,1
180	700 649 226	700 649 258	2.046	360	10,2
200	700 649 227	700 649 259	2.739	360	11,4
225	700 649 228	700 649 260	3.511	360	12,8
250	700 649 229	700 649 261	4.495	360	14,2
280	700 649 230	700 649 262	5.914	360	15,9
315	700 649 231	700 649 263	10.692	360	17,9
355	700 649 232	700 649 264	13.827	460	20,1
400	700 649 233	700 649 265	20.816	460	22,7
450	700 649 234	700 649 266	27.225	460	25,5
500	700 649 235	700 649 267	35.508	460	28,3
560	700 649 236	700 649 268	46.464	460	31,7
630	700 649 237	700 649 269	0.776	500	35,7

53 90 88

Reducer PE100 SDR11

Model:

- Conventional butt-welding according to DVS 2207 part 1
- IR = Infrared-(IR Plus®) compatible. Choose fusion parameters: PE100
- Up to d 315 injection moulded, above machined

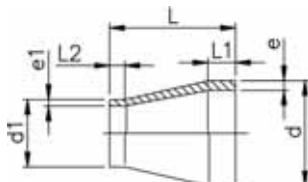

d [mm]	d1 [mm]	FM	Code	kg	L [mm]	L1 [mm]	L2 [mm]	e [mm]	e1 [mm]	PF
125	20	IR	753 908 637	0.008	50	20	18	2,3	1,9	2 68 240 011
132	20	IR	753 908 642	0.010	50	20	18	2,9	1,9	2 68 240 011
132	25	IR	753 908 641	0.006	50	20	18	2,9	2,3	2 68 240 011
140	20	IR	753 908 648	0.017	58	20	20	3,7	1,9	2 68 240 011
140	25	IR	753 908 647	0.017	55	20	18	3,7	2,3	2 68 240 011
140	32	IR	753 908 646	0.019	55	20	18	3,7	2,9	2 68 240 011
150	25	IR	753 908 654	0.025	60	20	18	4,6	2,3	2 68 240 011
150	32	IR	753 908 653	0.026	60	20	18	4,6	2,9	2 68 240 011
150	40	IR	753 908 652	0.032	60	20	18	4,6	3,7	2 68 240 011
163	32	IR	753 908 660	0.046	65	20	18	5,8	2,9	2 68 240 011
163	40	IR	753 908 659	0.051	65	20	18	5,8	3,7	2 68 240 011
163	50	IR	753 908 658	0.056	65	20	18	5,8	4,6	2 68 240 011
175	40	IR	753 908 666	0.070	68	20	20	6,8	3,7	2 68 240 011
175	50	IR	753 908 665	0.074	65	20	18	6,8	4,6	2 68 240 011
175	63	IR	753 908 664	0.081	65	20	18	6,8	5,8	2 68 240 011
190	63	IR	753 908 671	0.126	75	21	17	8,2	5,8	2 68 240 011
190	75	IR	753 908 670	0.132	75	22	17	8,2	6,8	2 68 240 011
1110	75	IR	753 908 677	0.219	90	28	17	10,0	6,8	2 68 240 011
1110	90	IR	753 908 676	0.240	90	28	20	10,0	8,2	2 68 240 011
2125	110	IR	753 908 680	0.350	100	32	26	11,4	10,0	2 68 240 005
2140	110	IR	753 908 685	0.437	110	35	28	12,7	10,0	2 68 240 005
2140	125	IR	753 908 684	0.474	110	35	28	12,7	11,4	2 68 240 005
2160	110	IR	753 908 690	0.612	120	40	25	14,6	10,0	2 68 240 005
2160	140	IR	753 908 688	0.674	120	40	33	14,6	12,7	2 68 240 005
1180	90	IR	753 908 877	0.678	157	45	22	16,4	8,2	2 68 240 011
1180	110	IR	753 908 878	0.991	157	45	28	16,4	10,0	2 68 240 011
1180	125	IR	753 908 879	0.528	136	45	32	16,4	11,4	2 68 240 011
1180	140	IR	753 908 880	0.963	136	45	35	16,4	12,7	2 68 240 011

table continued next page

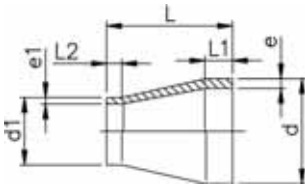

d [mm]	d1 [mm]	FM	Code	kg	L [mm]	L1 [mm]	L2 [mm]	e [mm]	e1 [mm]	PF
1 180	160	IR	753 908 881	1.094	136	45	40	16,4	14,6	2 68 240 011
2 200	160	IR	753 908 692	1.247	150	50	35	18,2	14,6	2 68 240 005
1 200	180	IR	753 908 883	1.419	151	50	45	18,2	16,4	2 68 240 011
2 225	110	IR	753 908 695	1.559	171	55	45	20,5	10,0	2 68 240 005
2 225	160	IR	753 908 696	1.643	160	55	37	20,5	14,6	2 68 240 005
1 225	180	IR	753 908 885	1.999	171	55	45	20,5	16,4	2 68 240 011
2 225	200	IR	753 908 697	1.844	160	55	48	20,5	18,2	2 68 240 005
1 250	160	--	753 908 890	2.416	194	60	40	22,7	14,6	2 68 240 011
3 250	180	--	753 900 001	2.513	175	60	55	22,7	16,4	2 68 240 040
3 250	200	--	753 900 002	2.450	180	60	60	22,7	18,2	2 68 240 040
1 250	225	--	753 908 887	2.766	182	60	55	22,7	20,5	2 68 240 011
3 280	200	--	753 900 004	3.540	205	70	50	25,4	18,2	2 68 240 040
1 280	225	--	753 908 892	1.943	105	30	20	25,4	20,5	2 68 240 011
1 280	250	--	753 908 891	1.802	70	30	18	25,4	22,7	2 68 240 011
3 315	200	--	753 900 007	3.996	225	80	50	28,6	20,5	2 68 240 040
1 315	225	--	753 908 897	3.491	130	30	30	28,6	20,5	2 68 240 011
1 315	250	--	753 908 896	2.379	100	30	20	28,6	22,7	2 68 240 011
1 315	280	--	753 908 895	1.684	63	30	18	28,6	25,4	2 68 240 011
3 355	225	--	753 900 011	4.700	245	90	55	32,3	20,5	2 68 240 040
3 355	250	--	753 900 012	4.400	245	90	60	32,3	22,7	2 68 240 040
3 355	280	--	753 900 013	4.100	245	90	70	32,3	25,4	2 68 240 040
3 355	315	--	753 900 014	3.700	245	90	80	32,3	28,6	2 68 240 040
3 400	225	--	753 900 015	7.963	260	95	60	36,4	20,5	2 68 240 040
3 400	250	--	753 900 016	6.800	260	95	70	36,4	22,7	2 68 240 040
3 400	280	--	753 900 017	6.200	260	95	70	36,4	25,4	2 68 240 040
3 400	315	--	753 900 018	10.829	260	95	80	36,4	28,6	2 68 240 040
3 400	355	--	753 900 019	4.800	260	95	90	36,4	32,3	2 68 240 040
3 450	280	--	753 900 020	9.000	230	60	70	40,9	25,4	2 68 240 040
3 450	315	--	753 900 021	8.000	230	60	80	40,9	28,6	2 68 240 040
3 450	355	--	753 900 022	7.400	230	60	90	40,9	32,3	2 68 240 040
3 450	400	--	753 900 023	6.600	230	60	95	40,9	36,4	2 68 240 040
3 500	315	--	753 900 024	12.000	230	60	80	45,5	28,6	2 68 240 040
3 500	355	--	753 900 025	10.800	230	60	90	45,5	32,3	2 68 240 040
3 500	400	--	753 900 026	10.000	230	60	95	45,5	36,4	2 68 240 040
3 500	450	--	753 900 027	8.300	200	60	60	45,5	40,9	2 68 240 040
3 710	500	--	753 900 035	24.157	190	84	40	64,5	45,4	2 68 240 040
3 710	560	--	753 900 036	21.770	170	81	40	64,5	50,8	2 68 240 040
3 710	630	--	753 900 037	17.845	140	71	40	64,5	57,2	2 68 240 040

Reducer PE100 SDR17/17.6

Model:

- Conventional butt-welding according to DVS 2207 part 1
- IR = Infrared-(IR Plus®) compatible. Choose fusion parameters: PE100
- Up to d 315 injection moulded, above machined

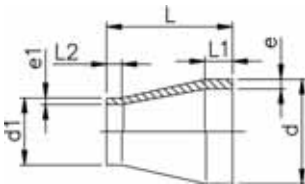

d [mm]	d1 [mm]	FM	Code	kg	L [mm]	L1 [mm]	L2 [mm]	e [mm]	e1 [mm]
50	40	IR	753 908 926	0.024	55	12	12	2,9	2,3
63	40	IR	753 908 927	0.036	65	16	12	3,6	2,3
63	50	IR	753 908 928	0.039	65	16	12	3,6	2,9
75	40	IR	753 908 904	0.041	71	19	12	4,3	2,3
75	50	IR	753 908 465	0.049	65	20	20	4,3	2,9
75	63	IR	753 908 464	0.056	65	20	20	4,3	3,6
90	63	IR	753 908 471	0.083	75	20	19	5,1	3,6
90	75	IR	753 908 470	0.092	75	20	20	5,1	4,3
110	75	IR	753 908 477	0.157	89	28	18	6,3	4,3
110	90	IR	753 908 476	0.168	90	28	20	6,3	5,1
125	110	IR	753 908 912	0.272	108	32	28	7,1	6,3
140	110	IR	753 908 917	0.330	115	35	28	8,0	6,3
140	125	IR	753 908 916	0.374	115	35	32	8,0	7,1
160	110	IR	753 908 922	0.456	124	40	28	9,1	6,3
160	140	IR	753 908 920	0.499	124	40	35	9,1	8,0
180	90	IR	753 908 975	0.897	157	45	22	10,2	5,1
180	110	IR	753 908 976	0.690	157	45	28	10,2	6,3
180	125	IR	753 908 977	0.616	136	45	32	10,2	7,1

table continued next page

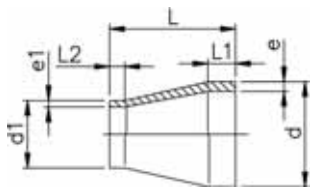

d [mm]	d1 [mm]	FM	Code	kg	L [mm]	L1 [mm]	L2 [mm]	e [mm]	e1 [mm]
180	140	IR	753 908 978	0.647	136	45	35	10,2	8,0
180	160	IR	753 908 979	0.713	136	45	40	10,2	9,1
200	160	IR	753 908 931	0.860	151	50	40	11,4	9,1
200	180	IR	753 908 981	0.971	151	50	45	11,4	10,2
225	110	IR	753 908 938	1.382	160	55	35	12,8	6,3
225	160	IR	753 908 933	1.120	171	55	40	12,8	9,1
225	180	IR	753 908 985	1.364	171	55	45	12,8	10,2
225	200	IR	753 908 932	1.234	171	55	50	12,8	11,4
250	160	--	753 908 939	1.601	194	60	40	14,2	9,1
250	180	--	753 902 801	1.690	175	60	55	14,8	10,7
250	200	--	753 902 802	1.899	180	60	60	14,8	11,9
250	225	--	753 908 937	1.853	182	60	55	14,2	12,8
280	200	--	753 902 804	2.585	205	70	50	16,6	11,9
280	225	--	753 908 944	1.423	105	30	20	15,9	12,8
280	250	--	753 908 943	1.002	70	30	18	15,9	14,2
315	200	--	753 902 807	2.907	225	80	50	18,7	11,9
315	225	--	753 908 950	2.154	130	30	20	17,9	12,8
315	250	--	753 908 949	1.702	100	30	20	17,9	14,2
315	280	--	753 908 999	1.598	63	30	18	17,9	15,9
355	225	--	753 902 811	4.700	245	90	55	21,1	13,4
355	250	--	753 902 812	9.425	245	90	60	21,1	14,8
355	280	--	753 902 813	4.280	245	90	70	21,1	16,6
355	315	--	753 902 814	3.700	245	90	80	21,1	18,7
400	225	--	753 902 815	4.600	260	95	60	23,7	13,4
400	250	--	753 902 816	4.400	260	95	70	23,7	14,8
400	280	--	753 902 817	5.922	260	95	70	23,7	16,6
400	315	--	753 902 818	3.520	260	95	80	23,7	18,7
400	355	--	753 902 819	7.163	260	95	90	23,7	21,1
450	280	--	753 902 820	6.340	230	60	70	26,7	16,6
450	315	--	753 902 821	5.400	230	60	80	26,7	18,7
450	355	--	753 902 822	5.000	230	60	90	26,7	21,1
450	400	--	753 902 823	8.098	230	60	95	26,7	23,7
500	315	--	753 902 824	8.100	230	60	80	29,7	18,7
500	355	--	753 902 825	8.424	230	60	90	29,7	21,1
500	400	--	753 902 826	7.974	230	60	95	29,7	23,7
500	450	--	753 902 827	5.500	200	60	60	29,7	26,7
560	400	--	753 902 828	9.900	230	60	95	33,2	23,7
560	450	--	753 902 829	8.600	200	60	60	33,2	26,7
560	500	--	753 902 830	7.600	200	60	60	33,2	29,7
630	400	--	753 902 831	15.100	230	60	95	37,4	23,7
630	450	--	753 902 832	13.700	200	60	60	37,4	26,7
630	500	--	753 902 833	12.000	200	60	60	37,4	29,7
630	560	--	753 902 834	9.800	200	60	60	37,4	33,2
710	500	--	753 902 835	16.750	190	84	40	42,1	29,7
710	560	--	753 902 836	15.014	170	81	40	42,1	33,2
710	630	--	753 902 837	12.215	140	71	40	42,1	37,4
800	560	--	753 902 838	22.731	200	85	40	47,4	33,2
800	630	--	753 902 839	20.475	180	85	40	47,4	37,4
800	710	--	753 902 840	16.774	150	78	40	47,4	42,1
900	630	--	753 902 841	32.055	220	96	40	53,3	37,4
900	710	--	753 902 842	27.731	190	89	40	53,3	42,1
900	800	--	753 902 843	22.854	160	85	40	53,3	47,4
1000	710	--	753 902 844	40.412	220	91	40	59,3	42,1
1000	800	--	753 902 845	33.910	180	86	40	59,3	47,4
1000	900	--	753 902 846	25.824	140	75	40	59,3	53,3

Reducing Bushes eccentric, PE100 SDR11

Model:

- Conventional butt fusion according to DVS2207
- Machined

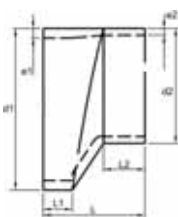

d1 [mm]	d2 [mm]	PN	Code	kg	L [mm]	L1 [mm]	L2 [mm]	e1 [mm]	e2 [mm]
63	50	16	700 647 600	1.000	120	35	35	5,8	4,6
75	50	16	700 647 601	1.000	120	40	35	6,8	4,6
75	63	16	700 647 602	1.000	120	40	35	6,8	5,8
90	63	16	700 647 603	1.000	140	50	50	8,2	5,8
90	75	16	700 647 604	1.000	140	50	50	8,2	6,8
110	75	16	700 647 605	1.000	140	50	50	10	6,8
110	90	16	700 647 606	1.000	140	50	50	10	8,2
125	90	16	700 647 607	1.000	140	50	50	11,4	5,1
125	110	16	700 647 608	1.000	140	50	50	11,4	10
140	90	16	700 647 609	1.000	140	50	50	12,7	8,2
140	110	16	700 647 610	1.000	140	50	50	12,7	10
160	90	16	700 647 611	1.000	140	50	54	14,6	8,2
160	110	16	700 647 612	1.000	120	40	45	14,6	10
160	125	16	700 647 613	1.000	110	40	44	14,6	11,4
160	140	16	700 647 614	1.000	90	40	33	14,6	12,7
180	125	16	700 647 615	1.000	130	40	52	16,4	11,4
180	140	16	700 647 616	1.000	110	40	41	16,4	12,7
180	160	16	700 647 617	1.000	90	40	33	16,4	16,4
200	140	16	700 647 618	1.000	140	40	50	18,2	12,7
200	160	16	700 647 619	1.000	120	40	41	18,2	14,6
200	180	16	700 647 620	1.000	100	40	43	18,2	16,4
225	160	16	700 647 621	1.000	140	40	57	20,5	14,6
225	180	16	700 647 622	1.000	120	40	48	20,5	16,4
225	200	16	700 647 623	1.000	100	40	40	20,5	18,2
250	180	16	700 647 624	1.000	150	40	54	22,7	16,4
250	200	16	700 647 625	1.000	130	40	55	22,7	18,2
250	225	16	700 647 626	1.000	110	40	40	22,7	20,5
280	200	16	700 647 627	1.000	160	40	58	25,4	18,2
280	225	16	700 647 628	1.000	130	40	52	25,4	20,5
280	250	16	700 647 629	1.000	110	40	47	25,4	22,7
315	225	16	700 647 630	1.000	160	40	62	28,6	20,5
315	250	16	700 647 631	1.000	140	40	57	28,6	22,7
315	280	16	700 647 632	1.000	120	40	54	28,6	25,4
355	250	16	700 647 633	1.000	180	40	74	32,2	22,7
355	250	16	700 647 634	1.000	150	40	61	32,2	25,4
355	315	16	700 647 635	1.000	120	40	51	32,2	28,6
400	280	16	700 647 636	1.000	200	40	85	36,3	25,4
400	315	16	700 647 637	1.000	170	40	75	36,3	28,6
400	355	16	700 647 638	1.000	130	40	58	36,3	32,2
450	355	16	700 647 639	1.000	210	40	86	40,9	28,6
450	355	16	700 647 640	1.000	180	40	79	40,9	32,2
450	400	16	700 647 641	1.000	140	40	65	40,9	36,3
500	400	16	700 647 642	1.000	260	40	107	45,4	28,6
500	355	16	700 647 643	1.000	220	40	91	45,4	32,2
500	400	16	700 647 644	1.000	190	40	86	45,4	36,3
500	450	16	700 647 645	1.000	140	40	65	45,4	40,9
560	450	16	700 647 646	1.000	200	40	91	50,8	40,9
560	500	16	700 647 647	1.000	150	40	70	50,8	45,4
630	500	16	700 647 648	1.000	220	40	99	57,2	45,4
630	560	16	700 647 649	1.000	170	40	84	57,2	50,8

Reducing Bushes eccentric, PE100 SDR17.6

Model:

- Conventional butt fusion according to DVS2207
- Machined

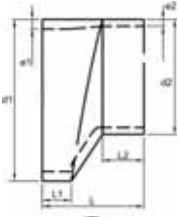

d1 [mm]	d2 [mm]	PN	Code	kg	L [mm]	L1 [mm]	L2 [mm]	e1 [mm]	e2 [mm]
63	50	10	700 647 650	1.000	120	35	35	3,6	2,9
75	50	10	700 647 651	1.000	120	40	35	4,3	2,9
75	63	10	700 647 652	1.000	120	40	35	4,3	3,6
90	63	10	700 647 653	1.000	140	50	50	5,1	3,6
90	75	10	700 647 654	1.000	140	50	50	5,1	4,3
110	75	10	700 647 655	1.000	140	50	50	6,3	4,3
110	90	10	700 647 656	1.000	140	50	50	6,3	5,1
125	90	10	700 647 657	1.000	140	50	50	7,1	5,1
125	110	10	700 647 658	1.000	140	50	50	7,1	6,3
140	90	10	700 647 659	1.000	140	50	50	8,0	5,1
140	110	10	700 647 660	1.000	140	50	50	8,0	6,3
160	90	10	700 647 661	1.000	140	50	54	9,5	5,4
160	110	10	700 647 662	1.000	120	40	45	9,5	6,6
160	125	10	700 647 663	1.000	110	40	44	9,5	7,4
160	140	10	700 647 664	1.000	90	40	33	9,5	8,3
180	125	10	700 647 665	1.000	130	40	52	10,7	7,4
180	140	10	700 647 666	1.000	110	40	41	10,7	8,3
180	160	10	700 647 667	1.000	90	40	33	10,7	9,5
200	140	10	700 647 668	1.000	140	40	50	11,9	8,3
200	160	10	700 647 669	1.000	120	40	41	11,9	9,5
200	180	10	700 647 670	1.000	100	40	43	11,9	10,7
225	160	10	700 647 671	1.000	140	40	57	13,4	9,5
225	180	10	700 647 672	1.000	120	40	48	13,4	10,7
225	200	10	700 647 673	1.000	100	40	40	13,4	11,9
250	180	10	700 647 674	1.000	150	40	54	14,8	10,7
250	200	10	700 647 675	1.000	130	40	55	14,8	11,9
250	225	10	700 647 676	1.000	110	40	40	14,8	13,4
280	200	10	700 647 677	1.000	160	40	58	16,6	11,9
280	225	10	700 647 678	1.000	130	40	52	16,6	13,4
280	250	10	700 647 679	1.000	110	40	47	16,6	14,8
315	225	10	700 647 680	1.000	160	40	62	18,7	13,4
315	250	10	700 647 681	1.000	140	40	57	18,7	14,8
315	280	10	700 647 682	1.000	120	40	54	18,7	16,6
355	250	10	700 647 683	1.000	180	40	74	21,1	14,8
355	280	10	700 647 684	1.000	150	40	61	21,1	16,6
355	315	10	700 647 685	1.000	120	40	51	21,1	18,7
400	280	10	700 647 686	1.000	200	40	85	23,7	16,6
400	315	10	700 647 687	1.000	170	40	75	23,7	18,7
400	355	10	700 647 688	1.000	130	40	58	23,7	21,1
450	315	10	700 647 689	1.000	210	40	86	26,7	18,7
450	355	10	700 647 690	1.000	180	40	79	26,7	21,1
450	400	10	700 647 691	1.000	140	40	65	26,7	23,7
500	315	10	700 647 692	1.000	260	40	107	29,7	18,7
500	355	10	700 647 693	1.000	220	40	91	29,7	21,1
500	400	10	700 647 694	1.000	190	40	86	29,7	23,7
500	450	10	700 647 695	1.000	140	40	65	29,7	26,7
560	450	10	700 647 696	1.000	200	40	91	33,2	26,7
560	500	10	700 647 697	1.000	150	40	70	33,2	29,7
630	500	10	700 647 698	1.000	220	40	99	37,4	29,7
630	560	10	700 647 699	1.000	170	40	84	37,4	33,2

End Cap PE100, SDR11

Model:

- Conventional butt fusion according to DVS2207
- Machined



d [mm]	PN	Code	L [mm]	L1 [mm]	e [mm]	r [mm]
63	16	700 665 184	30	15	5,8	5
75	16	700 665 185	30	15	6,8	5
90	16	700 665 186	30	15	8,2	5
110	16	700 665 187	30	15	10,0	5
125	16	700 665 188	35	15	11,4	5
140	16	700 665 189	40	15	12,7	5
160	16	700 665 190	40	15	14,6	6
180	16	700 665 191	45	15	16,4	6
200	16	700 665 192	50	15	18,2	6
225	16	700 665 193	50	15	20,5	8
250	16	700 665 194	55	15	22,7	8
280	16	700 665 195	60	15	25,4	8
315	16	700 665 196	65	15	28,6	8
355	16	700 665 197	70	15	32,2	8
400	16	700 665 198	75	15	36,3	10
450	16	700 665 199	80	15	40,9	10
500	16	700 665 200	90	14	45,4	10
560	16	700 665 201	100	14	50,8	10
630	16	700 665 202	110	15	57,2	10

End Cap PE100, SDR17.6

Model:

- Conventional butt fusion according to DVS2207
- Machined



d [mm]	PN	Code	L [mm]	L1 [mm]	e [mm]	r [mm]
63	10	700 665 260	30	15	3,6	5
75	10	700 665 261	30	15	4,3	5
90	10	700 665 262	30	15	5,1	5
110	10	700 665 263	30	15	6,3	5
125	10	700 665 264	30	15	7,1	5
140	10	700 665 265	30	15	8,0	5
160	10	700 665 266	35	15	9,1	6
180	10	700 665 267	40	15	10,2	6
200	10	700 665 268	40	15	11,4	6
225	10	700 665 269	45	15	12,8	8
250	10	700 665 270	45	15	14,2	8
280	10	700 665 271	45	15	15,9	8
315	10	700 665 272	55	15	17,9	8
355	10	700 665 273	55	15	20,1	8
400	10	700 665 274	60	15	22,7	10
450	10	700 665 275	70	15	26,7	10
500	10	700 665 276	75	14	29,7	10
560	10	700 665 277	80	14	33,2	10
630	10	700 665 278	90	15	37,4	10

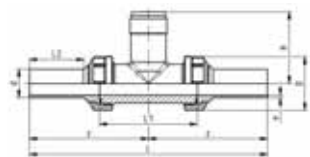

Installation fitting type 318 PE100 SDR 11 For butt fusion systems metric

Model:

- Body and union nut PP-H
- Threaded outlet 1 1/4" NPSM
- Union end with butt fusion spigot PE100

Range of use:

- compatible signet flow sensors: type 2551, 2537, 515, 8510, 2536, 8512
- compatible signet pH/ORP sensors: type 2724, 2725, 2726

Attention:

- sensor length depends on installation fitting

d [mm]	DN [mm]	PN	FM	EPDM Code	FPM Code	kg	
20	15	10	IR	753 318 006	753 318 036	0.136	
25	20	10	IR	753 318 007	753 318 037	0.190	
32	25	10	IR	753 318 008	753 318 038	0.250	
40	32	10	IR	753 318 009	753 318 039	0.356	
50	40	10	IR	753 318 010	753 318 040	0.510	
63	50	10	IR	753 318 011	753 318 041	0.800	

d [mm]	D [mm]	z [mm]	L [mm]	L1 [mm]	L2 [mm]	H [mm]	e [mm]	Sensor Type	
20	48	112	224	90	52	76	1.9	flow X0, pH XX	
25	58	121	242	100	53	78	2.3	flow X0, pH XX	
32	65	128	256	110	55	81	2.9	flow X0, pH XX	
40	79	136	272	110	60	85	3.7	flow X0, pH XX	
50	91	147	294	120	66	89	4.6	flow X0, pH XX	
63	105	158	316	130	70	95	5.8	flow X0, pH XX	

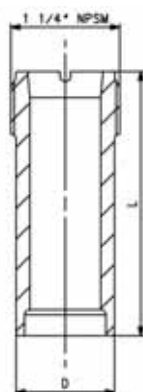

Installation fitting type 314 PE100

Model:

- Material: PE100
- Threaded outlet 1 1/4" NPSM
- for conventional hot gas back welding according to DVS 2207 part 3

Range of use:

- compatible signet flow sensors: type 2551, 2537, 515, 8510, 2536, 8512
- compatible signet pH/ORP sensors: type 2724, 2725, 2726

Attention:

- only for pressureless or low pressure application
- pressure rate depends on quality of hot gas back welding
- please consult the instruction manual
- Installation by trained and certified welders only
- sensor length depends on installation fitting

d [mm]	DN	PN* [bar]	Code	kg	D [mm]	L [mm]	Sensor Type	
75 - 180	65 - 150	-	753 314 000	0.042	37	68	flow X0, pH XX	
200 - 355	200 - 350	-	753 314 001	0.057	37	102	flow X1	
400 - 630	350 - 600	-	753 314 002	0.934	37	178	flow X2	

21 31 00

Installation fitting type 312 PE electrofusion system



Model:

- Material: Polyethylene
- Threaded outlet 1 ¼" NPSM

Range of use:

- compatible signet flow sensors: type 2551, 2537, 515, 8510, 2536, 8512
- compatible signet pH/ORP sensors: type 2724, 2725, 2726

Attention:

- sensor length depends on installation fitting

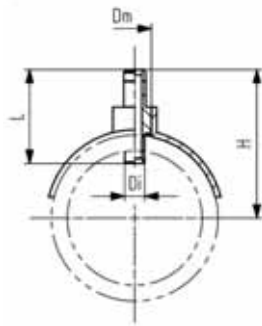

d [mm]	Code	kg	PN [bar]	H [mm]	Di [mm]	L [mm]	Dm [mm]	Sensor Type
75	753 312 012	1.000	16	126.10	37.8	101.6	63	flow x1
90	753 312 013	1.000	16	132.80	37.8	101.6	63	flow x1
110	753 312 014	1.000	16	142.00	37.8	101.6	63	flow x1
125	753 312 015	1.000	16	141.60	37.8	101.6	63	flow x1
140	753 312 016	1.000	16	145.90	37.8	101.6	63	flow x1
160	753 312 017	1.000	16	153.00	37.8	101.6	63	flow x1
180	753 312 018	1.000	16	235.20	37.8	177.8	63	flow x2
200	753 312 019	1.000	16	244.00	37.8	177.8	63	flow x2
225	753 312 020	1.000	16	250.30	37.8	177.8	63	flow x2
250	753 312 021	1.000	16	257.80	37.8	177.8	63	flow x2
280	753 312 022	1.000	16	267.80	37.8	177.8	63	flow x2
315	753 312 023	1.000	16	279.00	37.8	177.8	63	flow x2
355	753 312 024	1.000	16	344.64	37.8	177.8	63	flow x2
400	753 312 025	1.000	16	359.20	37.8	177.8	63	flow x2

Adaptor Fittings for Butt Fusion

53 91 02

Adaptor socket PE100 SDR11 metric Rp

Model:

- With butt fusion spigot **SDR11** and BSP parallel female thread Rp, reinforced
- Reinforcing ring stainless (A2)
- Connection to plastic or metal threads
- Do not use thread sealing pastes that are harmful to PE
- Install with low mechanical stress and avoid large cyclic temperature changes

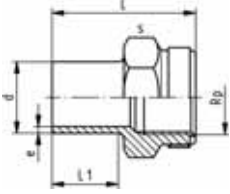

d [mm]	Rp [inch]	DN [mm]	FM	Code	kg	L [mm]	L1 [mm]	s [mm]	e [mm]
20	1/2	15	IR	753 910 266	0.018	48	23	32	1,9
25	3/4	20	IR	753 910 267	0.022	50	23	36	2,3
32	1	25	IR	753 910 268	0.038	54	23	46	2,9
40	1 1/4	32	IR	753 910 269	0.068	56	23	55	3,7
50	1 1/2	40	IR	753 910 270	0.083	60	23	65	4,6
63	2	50	IR	753 910 271	0.134	62	23	80	5,8

53 91 42

Adaptor socket PE100 SDR11 metric NPT

Model:

- Conventional butt-welding according to DVS 2207 part 1
- IR = Infrared-(IR Plus®) compatible. Choose fusion parameters: PE100
- NPT tapered female thread to ASTM F 1498
- Reinforcing ring stainless (A2)
- Connection to plastic or metal threads
- Do not use thread sealing pastes that are harmful to PE
- Install with low mechanical stress and avoid large cyclic temperature changes

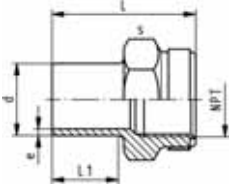

d [mm]	NPT [inch]	FM	Code	kg	L [mm]	L1 [mm]	s [mm]	e [mm]
20	1/2	IR	753 914 266	0.018	48	23	32	1,9
25	3/4	IR	753 914 267	0.022	50	23	36	2,3
32	1	IR	753 914 268	0.038	54	23	46	2,9
40	1 1/4	IR	753 914 269	0.058	56	23	55	3,7
50	1 1/2	IR	753 914 270	0.083	60	23	65	4,6
63	2	IR	753 914 271	0.134	62	23	80	5,8

53 91 05

Adaptor nipple PE100 SDR11 metric R

Model:

- With butt fusion spigot SDR11 and tapered male thread
- Do not use thread sealing pastes that are harmful to PE
- Install with low mechanical stress and avoid large cyclic temperature changes

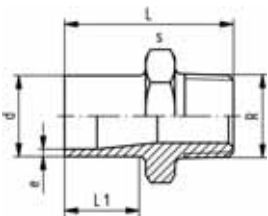

d [mm]	R [inch]	DN [mm]	FM	Code	kg	L [mm]	L1 [mm]	s [mm]	e [mm]
20	1/2	15	IR	753 910 556	0.013	51	23	32	1,9
25	3/4	20	IR	753 910 557	0.026	52	23	36	2,3
32	1	25	IR	753 910 558	0.028	55	23	46	3,0
40	1 1/4	32	IR	753 910 559	0.043	58	23	55	3,7
50	1 1/2	40	IR	753 910 560	0.063	60	23	65	4,6
63	2	50	IR	753 910 561	0.104	67	26	80	5,8

53 96 86

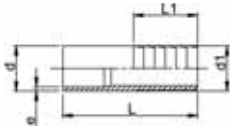

Hose connector PE100 SDR11 metric

Model:

- With butt fusion spigot **SDR11** and parallel hose connection

d [mm]	d1 [mm]	DN [mm]	FM	Code	kg	L [mm]	L1 [mm]	e [mm]
20	20	15	IR	753 968 606	0.007	64	27	1,9
25	25	20	IR	753 968 607	0.015	75	36	2,3
32	32	25	IR	753 968 608	0.023	82	36	2,9
40	40	32	IR	753 968 609	0.034	84	42	3,7
50	50	40	IR	753 968 610	0.057	90	48	4,6
63	60	50	IR	753 968 611	0.095	100	50	5,8

73 28 19

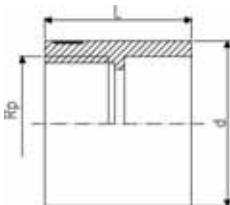

PE adaptor Female thread

- **PE 80 SDR 11** (ISO S5)
- 5 bar Gas / 12,5 bar Water
- Connection to plastic or metal
- Reinforcing ring stainless (A2)
- For ELGEF Plus Branch Saddle (53 131 000) d63 - 400mm, pipe SDR 11, d75 - 400mm, pipe SDR 17
- Parallel female thread
- *PE 100 SDR 11 (ISO S5)

d [mm]	Rp [inch]	Code	kg	L [mm]
63	1 ½	173 281 925	0.088	54
63	½	193 281 617	0.060	68

End Cap PE100, SDR11 with female thread

Model:

- Conventional butt fusion according to DVS2207
- Machined
- metric - Rp
- other thread-dimensions and NPT-thread available on request

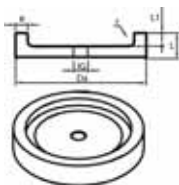

d [mm]	Rp [inch]	PN	Code	L [mm]	L1 [mm]	e [mm]	r [mm]
63	½	16	700 665 203	30	15	5,8	5
75	½	16	700 665 204	30	15	6,8	5
90	½	16	700 665 205	30	15	8,2	5
110	½	16	700 665 206	30	15	10	5
125	½	16	700 665 207	35	15	11,4	5
140	½	16	700 665 208	40	15	12,7	5
160	½	16	700 665 209	40	15	14,6	6
180	½	16	700 665 210	45	15	16,4	6
200	½	16	700 665 211	50	15	18,2	6
225	½	16	700 665 212	50	15	20,5	8
250	½	16	700 665 213	55	15	22,7	8
280	½	16	700 665 214	60	15	25,4	8
315	½	16	700 665 215	65	15	28,6	8
355	½	16	700 665 216	70	15	32,2	8
400	½	16	700 665 217	75	15	36,3	10
450	½	16	700 665 218	80	15	40,9	10

table continued next page

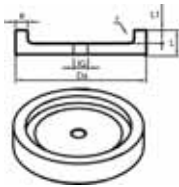

d [mm]	Rp [inch]	PN	Code	L [mm]	L1 [mm]	e [mm]	r [mm]
500	½	16	700 665 219	90	14	45,4	10
560	½	16	700 665 220	100	14	50,8	10
630	½	16	700 665 221	110	15	57,2	10

End Cap PE100, SDR17.6 with female thread

Model:

- Conventional butt fusion according to DVS2207
- Machined
- metric - Rp
- other thread-dimensions and NPT-thread available on request

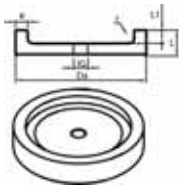

d [mm]	Rp [inch]	PN	Code	L [mm]	L1 [mm]	e [mm]	r [mm]
63	½	10	700 665 279	30	15	3,6	5
75	½	10	700 665 280	30	15	4,3	5
90	½	10	700 665 281	30	15	5,1	5
110	½	10	700 665 282	30	15	6,3	5
125	½	10	700 665 283	30	15	7,1	5
140	½	10	700 665 284	30	15	8,0	5
160	½	10	700 665 285	35	15	9,1	6
180	½	10	700 665 286	40	15	10,2	6
200	½	10	700 665 287	40	15	11,4	6
225	½	10	700 665 288	45	15	12,8	8
250	½	10	700 665 289	45	15	14,2	8
280	½	10	700 665 290	45	15	15,9	8
315	½	10	700 665 291	55	15	17,9	8
355	½	10	700 665 292	55	15	20,1	8
400	½	10	700 665 293	60	15	22,7	10
450	½	10	700 665 294	70	15	26,7	10
500	½	10	700 665 295	75	14	29,7	10
560	½	10	700 665 296	80	14	33,2	10
630	½	10	700 665 297	90	15	37,2	10



Instrument Installation Fittings PE, SDR11 with female thread

Model:

- Conventional butt fusion according to DVS2207
- Machined
- metric - Rp
- other thread-dimensions and NPT-thread available on request

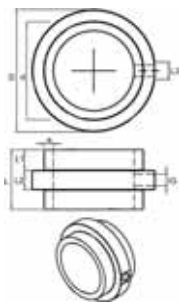

d [mm]	Rp [inch]	PN	Code	L [mm]	L1 [mm]	L2 [mm]	D [mm]	e [mm]
63	½	16	700 665 425	90	30	30	90	5,8
75	½	16	700 665 426	90	30	30	110	6,8
90	½	16	700 665 427	100	30	40	125	8,2
110	½	16	700 665 428	100	30	40	140	10
125	½	16	700 665 429	110	35	40	160	11,4
140	½	16	700 665 430	125	40	45	180	12,7
160	½	16	700 665 431	125	40	45	200	14,6
180	½	16	700 665 432	135	45	45	225	16,4
200	½	16	700 665 433	135	45	45	250	18,2
225	½	16	700 665 434	135	45	45	280	20,5
250	½	16	700 665 435	145	50	45	280	22,7
280	½	16	700 665 436	155	50	55	315	25,4
315	½	16	700 665 437	155	50	55	355	28,6
355	½	16	700 665 438	115	30	55	400	32,2
400	½	16	700 665 439	130	30	70	450	36,3



Instrument Installation Fittings PE, SDR17.6 with female thread

Model:

- Conventional butt fusion according to DVS2207
- Machined
- metric - Rp
- other thread-dimensions and NPT-thread available on request

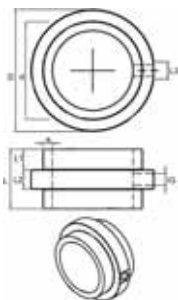

d [mm]	Rp [inch]	PN	Code	L [mm]	L1 [mm]	L2 [mm]	D [mm]	e [mm]
63	½	10	700 665 462	90	30	30	90	3,6
75	½	10	700 665 463	90	30	30	110	4,3
90	½	10	700 665 464	100	30	40	125	5,1
110	½	10	700 665 465	100	30	40	140	6,3
125	½	10	700 665 466	110	35	40	160	7,1
140	½	10	700 665 467	125	40	45	180	8,0
160	½	10	700 665 468	125	40	45	200	9,1
180	½	10	700 665 469	135	45	45	225	10,2
200	½	10	700 665 470	135	45	45	250	11,4
225	½	10	700 665 471	135	45	45	280	12,8
250	½	10	700 665 472	145	50	45	280	14,2
280	½	10	700 665 473	155	50	55	315	15,9
315	½	10	700 665 474	155	50	55	355	17,9
355	½	10	700 665 475	115	30	55	400	20,1
400	½	10	700 665 476	130	30	70	450	22,7

Unions for butt fusion

Union PE100 S5/SDR11



Model:

- Conventional butt-welding according to DVS 2207 part 1
- IR = Infrared- (IR Plus®) compatible.
- Gasket: O-Ring EPDM No. 48 41 00
- **For the dimensions d75-110 please see instructions for the installation**

d [mm]	PN	FM	EPDM Code	FPM Code	kg
20	16	IR	753 518 606	753 528 606	0.042
25	16	IR	753 518 607	753 528 607	0.052
32	16	IR	753 518 608	753 528 608	0.083
40	16	IR	753 518 609	753 528 609	0.151
50	16	IR	753 518 610	753 528 610	0.196
63	16	IR	753 518 611	753 528 611	0.406
75	10	IR	753 518 612	753 528 612	0.520
90	10	IR	753 518 613	753 528 613	0.562
110	10	IR	753 518 614	753 528 614	0.760

d [mm]	D [mm]	G [inch]	L [mm]	L1 [mm]	L2 [mm]	L3 [mm]	L4 [mm]	e [mm]
20	48	1	107	54.0	53.0	26	38	1,9
25	58	1 1/4	113	57.0	56.0	26	42	2,3
32	65	1 1/2	119	60.0	59.0	25	41	3,0
40	79	2	126	63.0	63.0	25	42	3,7
50	91	2 1/4	131	65.5	65.5	25	44	4,6
63	111	2 3/4	137	69.0	68.0	25	45	5,8
75	135	S107,5x3,6	132	66.0	65.5	24	34	6,8
90	135	S107,5x3,6	131	65.5	65.5	24	45	8,2
110	158	S127,5x3,6	131	65.5	65.5	25	40	10,0



Union PE100 S8.3/SDR17.6

Model:

- Conventional butt-welding according to DVS 2207 part 1
- IR = Infrared- (IR Plus®) compatible.
- Gasket: O-Ring EPDM No. 48 41 00
- **For the dimensions d75-110 please see instructions for the installation**

d [mm]	PN	FM	EPDM Code	FPM Code	kg
75	10	IR	753 518 412	753 528 412	0.476
90	10	IR	753 518 413	753 528 413	0.483
110	10	IR	753 518 414	753 528 414	0.663

d [mm]	D [mm]	G [inch]	L [mm]	L1 [mm]	L2 [mm]	e [mm]
75	135	S107,5x3,6	132	66.0	66.0	4,3
90	135	S107,5x3,6	131	65.5	65.5	5,1
110	158	S127,5x3,6	131	65.5	65.5	6,3

Instructions for the installation of unions in PP, PE d 75, d 90 and d 110

The newest generation of plastic unions in the above materials and dimensions has been fitted with a state-of-the-art, plastics-oriented buttress thread. You therefore have a product in which the nominal pressure and the safety reserve have been dramatically increased. Also new are the butt fusion versions. In this connection, there are a few points which you must be aware of.

Caution

- ① The threads of the union nut and bush have been reworked for PP, PVDF and PE! When using individual parts, please check prior to installation if the threads of the union bush and the union nut coincide.



Union bush with trapezoid thread on union nut with trapezoid thread
or
Union bush with buttress thread on union nut with buttress thread

Tip

To make installation of the union easier, wet the union nut.

- ② For the dimensions d90 and d110 we advise fusing the complete union, if possible (or slide the union nut to the collar of the union end) because after fusion the union nut cannot be slid over the fusion bead. (Fig. 1)
- ③ For design reasons, it is theoretically possible to combine different nominal diameters of union ends and nuts. To make sure combinations are technically correct, you can find the code numbers of the single parts and spare parts for each union in the Tables 1-3.

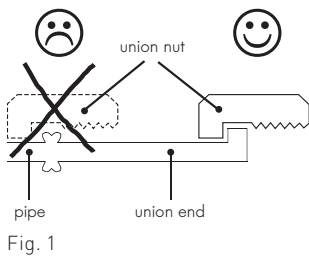

Fig. 1

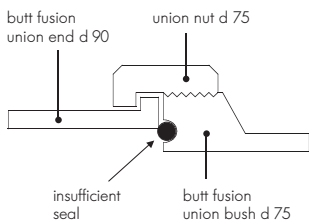

Fig. 2

Caution

Only use union bushes and union ends with the same nominal diameter!

A butt fusion union bush d75 may not be combined with a butt fusion union end d90 to form a reducer because this can cause leakage, as illustrated to the left. (Fig. 2)

Markings on the union nuts

SF/MS = socket fusion, BF/ST = butt fusion

SF/MS 75 specified for socket fusion d75
BF/ST 75-90 specified for butt fusion d75-75 and d90-90

SF/MS 90 specified socket fusion d90
BF/ST 110 specified butt fusion d110

110 specified for socket fusion d110

Tip

We recommend changing materials only for the union end for installation reasons.

Selection tables for single parts and spare parts



Butt fusion

Socket fusion

Table 1

Single parts for **PP-H** unions d 75, d 90 and d 110

d	BF/ST	SF/MS	SDR	PN	Code union end	Code union bush	Code union nut*
75	≡≡	≡≡	11	10	727 608 512	727 648 512	727 690 422
			17.6	6	727 608 412	727 648 412	727 690 422
	—		10	727 600 112	727 640 172	727 690 422	
90	≡≡	≡≡	11	10	727 608 513	727 648 513	727 690 422
			17.6	6	727 608 413	727 648 413	727 690 422
	—		10	727 600 113	727 640 173	727 690 423	
110	≡≡	≡≡	11	10	727 608 514	727 648 514	727 690 423
			17.6	6	727 608 414	727 648 414	727 690 423
	—		10	727 600 114	727 640 174	727 690 424	

Table 2

Single parts for **PE 100** unions d 75, d 90 and d 110

d	BF/ST	SF/MS	SDR	PN	Code union end	Code union bush	Code union nut*
75	≡≡	≡≡	11	10	753 608 612	753 648 612	727 690 442
			17.6	10	753 608 412	753 648 412	727 690 442
90	≡≡		11	10	753 608 613	753 648 613	727 690 442
		17.6	10	753 608 413	753 648 413	727 690 442	
110	≡≡	11	10	753 608 614	753 648 614	727 690 443	
		17.6	10	753 608 414	753 648 414	727 690 443	

Table 3

O-Rings for PP-H, PE 100

d	BF/ST	SF/MS	SDR	PN	Code O-Ring EPDM ¹	Code O-Ring FPM ¹
75	≡≡	≡≡		16	748 410 013	749 410 013
				16	748 410 014	749 410 014
90	≡≡		16		748 410 014	749 410 014
		16		748 410 015	749 410 015	
110	≡≡	16		748 410 015	749 410 015	
		16		748 410 016	749 410 016	

* Union nuts overlap several dimensions

¹ Flange adaptor O-rings, one size smaller in nominal dimensions, are used for the d 75–110 butt-fusion unions

53 60 86

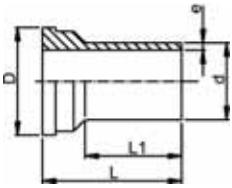

Union Ends, PE100 SDR11

Model:

- Conventional butt-welding according to DVS 2207 part 1
- IR = Infrared- (IR Plus®) compatible.
- For the dimensions d75-110 please see instructions for the installation

d [mm]	PN	FM	Code	kg	D [mm]	L [mm]	L1 [mm]	e [mm]
20	16	IR	753 508 606	0.011	30	54	38	1,9
25	16	IR	753 508 607	0.018	39	57	42	2,3
32	16	IR	753 508 608	0.027	45	60	41	2,9
40	16	IR	753 508 609	0.044	57	63	42	3,7
50	16	IR	753 508 610	0.061	63	66	44	4,6
63	16	IR	753 508 611	0.100	78	69	45	5,8
75	10	IR	753 608 612	0.147	101	66	34	6,8
90	10	IR	753 608 613	0.156	101	66	45	8,2
110	10	IR	753 608 614	0.226	121	66	40	10,0

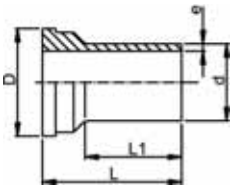

Union Ends, PE100 SDR17,6

Model:

- Conventional butt-welding according to DVS 2207 part 1
- IR = Infrared- (IR Plus®) compatible.
- For the dimensions d75-110 please see instructions for the installation

d [mm]	PN	FM	Code	kg	D [mm]	L [mm]	L1 [mm]	e [mm]
75	10	IR	753 608 412	0.124	101	66	34	4,3
90	10	IR	753 608 413	0.131	101	66	45	5,1
110	10	IR	753 608 414	0.178	121	66	40	6,3

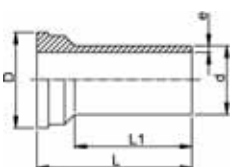

Union Ends long, PE100

Model:

- For butt-, IR Plus® and electrofusion
- Suitable for unions, tank connectors and diaphragm valves Type 514

d [mm]	PN	FM	Code	kg	D [mm]	L [mm]	L1 [mm]	e [mm]
20	16	IR	753 508 616	0.006	30	67	52	1,9
25	16	IR	753 508 617	0.019	39	71	53	2,3
32	16	IR	753 508 618	0.027	45	73	55	2,9
40	16	IR	753 508 619	0.048	57	81	60	3,7
50	16	IR	753 508 620	0.069	63	87	66	4,6
63	16	IR	753 508 621	0.120	78	93	70	5,8

53 64 86

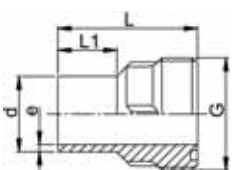

Union Bushes, PE100 SDR11

Model:

- Conventional butt-welding according to DVS 2207 part 1
- IR = Infrared- (IR Plus®) compatible.
- Gasket: O-Ring EPDM No. 48 41 00
- For the dimensions d75-110 please see instructions for the installation

d [mm]	PN	FM	Code	kg	G [inch]	L [mm]	L1 [mm]	e [mm]
20	16	IR	753 648 606	0.016		1	54	1,9
25	16	IR	753 648 607	0.025		1 1/4	57	2,3
32	16	IR	753 648 608	0.035		1 1/2	60	2,9
40	16	IR	753 648 609	0.057		2	63	3,7
50	16	IR	753 648 610	0.077		2 1/4	66	4,6
63	16	IR	753 648 611	0.128		2 3/4	69	5,8
75	10	IR	753 648 612	0.181		S107,5x3,6	66	6,8
90	10	IR	753 648 613	0.192		S107,5x3,6	66	8,2
110	10	IR	753 648 614	0.272		S127,5x3,6	66	10

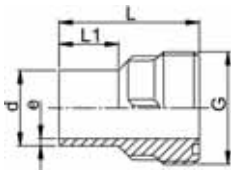

Union Bushes, PE100 SDR17,6

Model:

- Conventional butt-welding according to DVS 2207 part 1
- IR = Infrared- (IR Plus®) compatible.
- For the dimensions d75-110 please see instructions for the installation

d [mm]	PN	FM	Code	kg	G [inch]	L [mm]	L1 [mm]	e [mm]
75	10	IR	753 648 412	0.158	S107.5x3.6	66	24	4,3
90	10	IR	753 648 413	0.161	S107.5x3.6	66	24	5,1
110	10	IR	753 648 414	0.216	S127.5x3.6	66	25	6,3

33 69 04

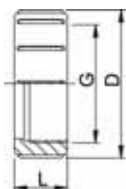

Union Nuts, PE-GF

Model:

- PE glass-fibre reinforced
- For the dimensions d75-110 please see instructions for the installation
- * PP glass fibre reinforced

d-d [mm]	Code	kg	G [inch]	D [mm]	L [mm]
20 -	733 690 406	0.022	1	48	24
25 -	733 690 407	0.036	1 1/4	58	26
32 -	733 690 408	0.042	1 1/2	65	28
40 -	733 690 409	0.068	2	79	31
50 -	733 690 410	0.097	2 1/4	91	35
63 -	733 690 411	0.164	2 3/4	111	39
* 75 - 90	727 690 442	0.202	S107,5x3,6	135	40
* 90 - 110	727 690 443	0.277	S127,5x3,6	158	43

EPDM 48 41 00
FPM 49 41 00

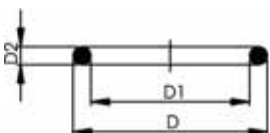

O-Ring Gaskets

Model:

- For unions and adaptor unions
- Hardness approx. 65° Shore
- EPDM minimum temperature -40°C
- FPM minimum temperature -15°C

* for unions PVC-U, PVC-C and ABS: 21 51 01, 21 51 11, 21 53 03, 21 53 08, 21 55 04, 21 55 13, 21 55 18, 23 51 01 and 29 51 01 only

d [mm]	DN [mm]	EPDM Code	FPM Code	kg	D [mm]	D1 [mm]	D2 [mm]
20	15	748 410 006	749 410 006	0.001	27	20	3.53
25	20	748 410 007	749 410 007	0.002	35	28	3.53
32	25	748 410 008	749 410 008	0.002	40	33	3.53
40	32	748 410 009	749 410 009	0.007	51	41	5.34
50	40	748 410 010	749 410 010	0.060	58	47	5.34
63	50	748 410 011	749 410 011	0.003	70	60	5.34

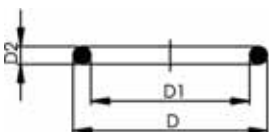

O-Ring Gasket, FPM black

Model:

- for unions PP-H, PE100 and PVDF butt fusion
- d75 748 410 013 (EPDM), 749 410 013 (FPM)
- d90 748 410 014 (EPDM), 749 410 014 (FPM)
- d110 748 410 015 (EPDM), 749 410 015 (FPM)

EPDM Code	FPM Code	kg	D [mm]	D1 [mm]	D2 [mm]
748 410 013	749 410 013	0.011	80		
748 410 014	749 410 014	0.012	93		
748 410 015	749 410 015	0.015	112		

Flange Adaptors, Flanges and Gaskets for Butt Fusion

538000

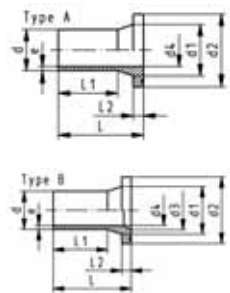
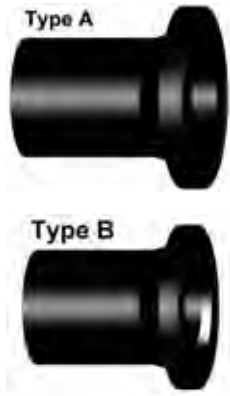

Flange adaptor PE100 S5/SDR11 Combined jointing face: flat and serrated

Model:

- Long spigot
- For butt-, IR Plus® and electrofusion
- Suitable for flange connections to metric (from d110 also to ANSI/ASME B16.5)
- Up to d315, suitable for butterfly valve type 567/568
Above use PE100 Adaptor for butterfly valves SDR11 (d355-d800)
- Up to d280, suitable for butterfly valve type 037/038/039
Above use PE100 Adaptor for butterfly valves SDR11 (d315-d800)
- Gasket d20-d630: Profile flange gasket NBR No. 45 44 07, EPDM No. 48 44 07
- Gasket d710-d1000: flat gasket EPDM No. 48 40 03
- 10 bar Gas / 16 bar Water
- Type A without chamfer, Type B with chamfer

d [mm]	DN [mm]	FM	Code	kg
20	15	IR	753 800 006	0.022
25	20	IR	753 800 007	0.037
32	25	IR	753 800 008	0.059
40	32	IR	753 800 009	0.081
50	40	IR	753 800 010	0.129
63	50	IR	753 800 011	0.187
75	65	IR	753 800 012	0.314
90	80	IR	753 800 013	0.471
110	100	IR	753 800 014	0.706
125	100	IR	753 800 015	0.883
140	125	IR	753 800 016	1.348
160	150	IR	753 800 017	1.718
180	150	IR	753 800 018	2.035
200	200	IR	753 800 019	2.899
225	200	IR	753 800 020	3.208
250	250	--	753 800 021	4.878
280	250	--	753 800 022	4.925
315	300	--	753 800 023	7.135
355	350	--	753 800 024	10.400
400	400	--	753 800 025	14.600
450	500	--	753 800 026	24.800
500	500	--	753 800 027	27.400
560	600	--	753 800 028	40.000
630	600	--	753 800 029	42.300
710	700	--	753 800 030	56.379
800	800	--	753 800 033	72.636

d [mm]	DN [mm]	d1 [mm]	d2 [mm]	d3 [mm]	d4 [mm]	L [mm]	L1 [mm]	L2 [mm]	e [mm]	PF	Type
20	15	27	45		16	85	41	7	1.9	2 51 301 001	A
25	20	33	58		20	85	41	9	2.3	2 51 301 001	A
32	25	40	68		26	85	44	10	3.0	2 51 301 001	A
40	32	50	78		32	85	49	11	3.7	2 51 301 001	A
50	40	61	88		40	105	55	12	4.6	2 51 301 001	A
63	50	75	102		51	98	69	14	5.8	2 51 301 001	A
75	65	89	122	66	61	125	89	16	6.8	2 51 301 001	B
90	80	105	138	78	73	140	103	17	8.2	2 51 301 001	B
110	100	125	158	100	90	160	114	18	10.0	2 51 301 001	B
125	100	132	158	114	102	170	125	25	11.4	2 51 301 001	B
140	125	155	188	127	114	200	147	25	12.7	2 51 301 001	B
160	150	175	212	151	130	200	147	25	14.6	2 51 301 001	B
180	150	180	212	158	147	200	170	30	16.4	2 51 301 001	B
200	200	232	268	203	163	200	128	32	18.2	2 51 301 001	B
225	200	235	268	210	184	200	138	32	20.5	2 51 301 001	B
250	250	285	320	245	204	219	138	35	22.7	2 51 301 002	B
280	250	291	320	265	229	231	144	35	25.4	2 51 301 002	B

table continued next page

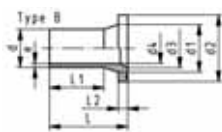
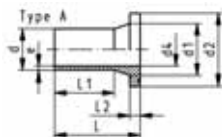

d [mm]	DN [mm]	d1 [mm]	d2 [mm]	d3 [mm]	d4 [mm]	L [mm]	L1 [mm]	L2 [mm]	e [mm]	PF	Type
315	300	335	370	300	257	239	158	35	28.6	2 51 301 002	B
355	350	373	430	340	290	260	176	40	32.3	2 51 301 008	B
400	400	427	482	385	327	290	186	46	36.3	2 51 301 008	B
450	500	514	585	400	368	333	195	60	40.9	2 51 301 008	B
500	500	530	585	440	409	350	212	60	45.5	2 51 301 008	B
560	600	615	685	490	458	365	230	60	50.9	2 51 301 008	B
630	600	642	685	545	515	385	250	60	57.3	2 51 301 008	B
710	700	737	800		581	400	280	60	64.5	2 51 301 008	A
800	800	840	905		652	400	280	65	74.0	2 51 301 008	A

53 80 00

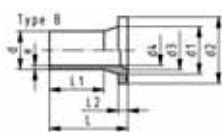
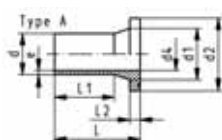

Flange adaptor LS PE100 SDR11 Combined jointing face: flat and serrated

Model:

- For butt-, IR Plus® and electrofusion
- Suitable for flange connections to **ANSI/ASME B 16.5**
- Suitable for butterfly valve type 567/568 and 037/038/039
- Gasket: Profile flange gasket NBR No. 45 44 07, EPDM No. 48 44 07
- 10 bar Gas / 16 bar Water

* Type B with chamfer

d [mm]	DN [mm]	FM	Code	kg	d1 [mm]	d2 [mm]	d3 [mm]	d4 [mm]	L [mm]	L1 [mm]	L2 [mm]	e [mm]
25	20	IR	753 800 057	0.031	33	54		20	85	41	9	2.3
32	25	IR	753 800 058	0.046	40	63		26	85	44	10	3.0
40	32	IR	753 800 059	0.070	50	73		32	85	49	11	3.7
50	40	IR	753 800 060	0.098	61	82		40	105	55	12	4.6
* 90	80	IR	753 800 063	0.423	105	133		73	140	85	17	8.2

538000

538001

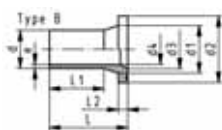
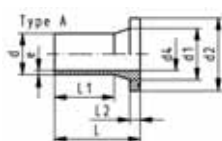

Flange adaptor PE100 SDR17/17.6 Combined jointing face: flat and serrated

Model:

- Long spigot
- For butt-, IR Plus® and electrofusion
- Suitable for flange connections to metric (**from d110 also to ANSI/ASME B16.5**)
- Up to d315, suitable for butterfly valve type 567/568
Above use PE100 Adaptor for butterfly valves SDR17/17.6 (d355-d1200)
- Up to d280, suitable for butterfly valve type 037/038/039
Above use PE100 Adaptor for butterfly valves SDR17/17.6 (d315-d1200)
- Gasket d20-d630: Profile flange gasket NBR No. 45 44 07, EPDM No. 48 44 07
- Gasket d710-d1000: flat gasket EPDM No. 48 40 03
- 5 bar Gas / 10 bar Water
- Type A without chamfer, Type B with chamfer

d [mm]	DN [mm]	FM	Code	kg
50	40	IR	753 800 085	0.107
63	50	IR	753 800 086	0.168
75	65	IR	753 800 087	0.260
90	80	IR	753 800 088	0.367
110	100	IR	753 800 089	0.571
125	100	IR	753 800 090	0.684
140	125	IR	753 800 091	1.035
160	150	IR	753 800 092	1.342
180	150	IR	753 800 093	1.469
200	200	IR	753 800 094	2.297

table continued next page

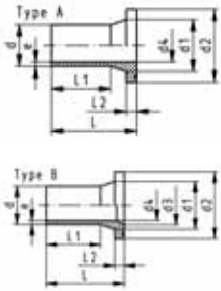

d [mm]	DN [mm]	FM	Code	kg
225	200	IR	753 800 095	2.456
250	250	--	753 800 096	3.500
280	250	--	753 800 097	3.714
315	300	--	753 800 098	5.470
355	350	--	753 800 099	16.200
400	400	--	753 800 100	10.300
450	500	--	753 800 101	15.800
500	500	--	753 800 102	19.995
560	600	--	753 800 103	27.500
630	600	--	753 800 104	30.000
710	700	--	753 800 105	39.376
800	800	--	753 800 106	50.759
900	900	--	753 800 107	64.202
1000	1000	--	753 800 108	79.495

d [mm]	d1 [mm]	d2 [mm]	d3 [mm]	d4 [mm]	L [mm]	L1 [mm]	L2 [mm]	e [mm]	PF	Type
50	61	88		44	104	55	12	3.0	2 51 301 001	A
63	75	102		55	120	65	14	3.8	2 51 301 001	A
75	89	122		66	130	75	16	4.5	2 51 301 001	A
90	105	138		79	140	103	17	5.4	2 51 301 001	A
110	125	158		96	160	117	18	6.6	2 51 301 001	A
125	132	158	114	110	170	125	25	7.4	2 51 301 001	B
140	155	188	127	123	200	147	25	8.3	2 51 301 001	B
160	175	212	158	141	200	147	25	9.5	2 51 301 001	B
180	180	212		158	200	170	30	10.7	2 51 301 001	A
200	232	268	203	176	200	128	32	11.9	2 51 301 001	B
225	235	268	210	198	200	138	32	13.4	2 51 301 001	B
250	285	320	245	220	220	148	25	14.8	2 51 301 002	B
280	291	320	265	246	230	154	25	16.6	2 51 301 002	B
315	335	370	300	277	242	166	36	18.7	2 51 301 002	B
355	373	430	340	312	261	179	30	21.1	2 51 301 008	B
400	427	483	385	352	290	196	33	23.7	2 51 301 008	B
450	514	585		396	333	195	60	26.7	2 51 301 008	A
500	530	585		440	350	212	60	29.7	2 51 301 008	A
560	615	685		493	365	230	60	33.2	2 51 301 008	A
630	642	685		555	385	250	60	37.4	2 51 301 008	A
710	737	800		626	400	280	50	42.1	2 51 301 008	A
800	840	905		705	400	280	52	47.4	2 51 301 008	A
900	944	1005		793	400	260	55	53.3	2 51 301 008	A
1000	1047	1110		881	400	260	60	59.3	2 51 301 008	A

537987

Adaptor for butterfly valves PE100 SDR11 Jointing face flat metric



Model:

- Conventional butt-welding according to DVS 2207 part 11
- Suitable for butterfly valves type 567/568 and 037/038/039

Note:

* available starting Q1 2013

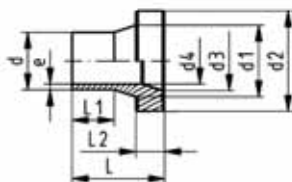

d [mm]	DN [mm]	Code	kg	d1 [mm]	d2 [mm]	d3 [mm]	d4 [mm]	L [mm]	L1 [mm]	L2 [mm]	e [mm]
* 315	300	753 798 723									
355	350	753 798 724	7.805	373	430	346	312	180	90	65	32.2
400	400	753 798 725	10.057	427	482	404	352	196	95	90	36.3
450	450	753 798 726	13.448	467	533	460	396	195	60	70	40.9
500	500	753 798 727	15.001	530	585	500	440	144	60	90	45.4
560	600	753 798 728	29.270	615	685	610	493	227	60	147	50.8
630	600	753 798 729	23.042	642	685	610	555	149	60	132	57.2
710	700	753 798 730	33.765	737	800	701	625	175	20	155	64.5
800	800	753 798 731	41.787	840	905	785	705	142	18	140	72.6

537987

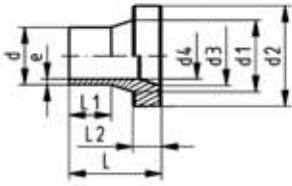

Adaptor for butterfly valves PE100 SDR17/17.6 Joining face flat metric

Model:

- Conventional butt-welding according to DVS 2207 part 1
- Suitable for butterfly valves type 567/568 and 037/038/039

Note:

* available starting Q1 2013

d [mm]	DN [mm]	Code	kg	d1 [mm]	d2 [mm]	d3 [mm]	d4 [mm]	L [mm]	L1 [mm]	L2 [mm]	e [mm]
* 315	300	753 798 748									-
355	350	753 798 749	6.479	373	430	346	312	180	90	65	21.1
400	400	753 798 750	8.426	427	482	404	352	196	95	69	23.7
450	450	753 798 751	9.570	467	533	460	396	195	60	90	26.7
500	500	753 798 752	8.263	530	585	500	440	144	60	90	29.7
560	600	753 798 753	17.307	615	685	610	493	227	60	92	33.2
630	600	753 798 754	12.122	642	685	610	555	149	60	71	37.4
710	700	753 798 755	21.505	737	800	701	625	175	20	105	42.1
800	800	753 798 756	21.841	840	905	785	705	142	18	74	47.4
900	900	753 798 757	34.187	947	1005	890	793	189	15	104	53.3
1000	1000	753 798 758	43.733	1047	1110	994	881	204	10	124	59.3
1200	1200	753 798 759	106.295	1256	1330	1860	1057	377	160	126	71.2

537988

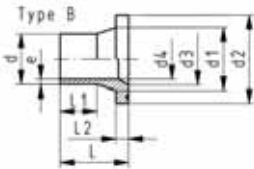
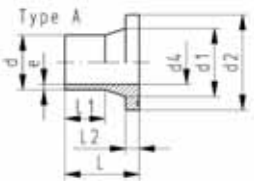

Flange adaptor PE100 SDR11 Joining face combination serrated/flat metric

Model:

- Conventional butt-welding according to DVS 2207 part 1
- Up to d315, suitable for butterfly valve type 567/568
Above use PE100 Adaptor for butterfly valves SDR11 (d355-d800)
- Up to d280, suitable for butterfly valve type 037/038/039
Above use PE100 Adaptor for butterfly valves SDR11 (d315-d800)
- Gasket d20-d630: Profile flange gasket NBR No. 45 44 07, EPDM No. 48 44 07
- Gasket d710-d1000: flat gasket EPDM No. 48 40 03

d [mm]	DN [mm]	Code	kg	d1 [mm]	d2 [mm]	d3 [mm]	d4 [mm]	L [mm]	L1 [mm]	L2 [mm]	e [mm]	Type
250	250	753 798 826	3.087	285	320	245	204	121	54	35	22,7	B
280	250	753 798 827	3.760	291	320	265	229	119	69	35	25,4	B
315	300	753 798 828	4.385	335	370	300	257	166	88	35	28,6	B
355	350	753 798 829	1.795	373	430	340	290	187	98	40	32,2	B
400	400	753 798 830	8.760	427	482	385	327	196	106	45	36,3	B
450	500	753 798 831	14.680	514	585	400	368	139	61	60	40,9	B
500	500	753 798 832	13.630	530	585	440	409	138	62	60	45,4	B
560	600	753 798 833	19.380	615	684	490	458	135	20	60	50,8	B
630	600	753 798 834	16.500	642	684	545	516	135	40	60	57,2	B
710	700	753 798 835	21.586	737	800		581	120	20	60	64,5	B
800	800	753 798 836	28.505	840	905		655	120	18	65	72,6	B

537988

Flange adaptor PE100 S8.3/SDR17.6 Jointing face combination serrated/flat metric

Type A



Type B

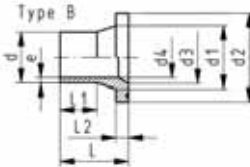
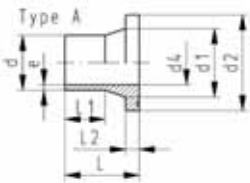

Model:

- Conventional butt-welding according to DVS 2207 part 1
- Up to d315, suitable for butterfly valve type 567/568
Above use PE100 Adaptor for butterfly valves SDR17/17.6 (d355-d1200)
- Up to d280, suitable for butterfly valve type 037/038/039
Above use PE100 Adaptor for butterfly valves SDR17/17.6 (d315-d1200)
- Gasket d20-d630: Profile flange gasket NBR No. 45 44 07, EPDM No. 48 44 07
- Gasket d710-d1000: flat gasket EPDM No. 48 40 03

d [mm]	DN [mm]	Code	kg
250	250	753 798 851	2.272
280	250	753 798 852	2.154
315	300	753 798 853	3.819
355	350	753 798 854	4.155
400	400	753 798 855	7.810
450	500	753 798 856	10.914
500	500	753 798 857	9.865
560	600	753 798 858	14.875
630	600	753 798 859	12.515
710	700	753 798 860	15.878
800	800	753 798 861	20.948
900	900	753 798 862	29.183
1000	1000	753 798 863	36.209

d [mm]	DN [mm]	d1 [mm]	d2 [mm]	d3 [mm]	d4 [mm]	L [mm]	L1 [mm]	L2 [mm]	e [mm]	Type
250	250	285	320	245	220	121	61	25	14,8	B
280	250	291	320	265	246	119	69	25	16,6	B
315	300	335	370	300	277	164	86	25	18,7	B
355	350	373	430	340	312	180	100	30	21,1	B
400	400	427	482	385	352	197	110	33	23,7	B
450	500	514	585		396	141	64	46	26,7	B
500	500	530	585		440	141	67	46	29,7	B
560	600	615	685		493	142	60	50	33,2	B
630	600	642	685		555	144	71	50	37,4	B
710	700	737	800		626	120	20	50	42,1	A
800	800	840	905		705	120	18	52	47,4	A
900	900	944	1005		793	140	15	55	53,3	A
1000	1000	1047	1110		881	140	10	60	59,3	A

33 80 80

Outlet flange adaptor PE80 SDR11

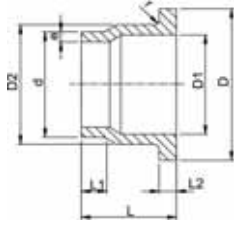

Model:

- Conventional butt-welding according to DVS 2207 part 1
- Suitable for wafer check valves Type 369

Attention:

- In conjunction with outlet flange adaptors, **flange rings for socket systems** must be used.

d [mm]	DN [mm]	Code	kg	D [mm]	D1 [mm]	D2 [mm]	L [mm]	L1 [mm]	L2 [mm]	e [mm]	r [mm]
40	32	733 808 034	0.073	80	37	50	64	30	11	3,7	3
50	40	733 808 035	0.104	90	43	61	67	30	12	4,6	3
63	50	733 808 036	0.172	105	54	76	74	30	14	5,8	4
75	65	733 808 037	0.242	125	70	90	78	30	16	6,8	4
90	80	733 808 038	0.348	140	82	108	87	35	17	8,2	4
110	100	733 808 039	0.508	160	105	131	102	41	18	10,0	4
140	125	733 808 041	0.976	190	130	165	124	47	25	12,7	4
160	150	733 808 042	1.337	215	158	188	149	52	25	14,6	4
225	200	733 808 045	2.814	270	206	248	180	55	32	20,5	4
280	250	733 808 047	3.550	325	259	308	240	63	35	25,4	4
315	300	733 808 048	4.960	375	308	346	272	66	35	28,6	4

33 80 80

Outlet flange adaptor PE80 SDR17.6

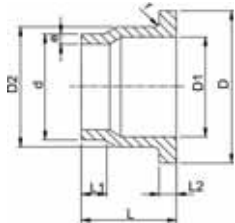

Model:

- Conventional butt-welding according to DVS 2207 part 11
- Suitable for wafer check valves Type 369

Attention:

- In conjunction with outlet flange adaptors, **flange rings for socket systems** must be used.

d [mm]	DN [mm]	Code	kg	D [mm]	D1 [mm]	D2 [mm]	L [mm]	L1 [mm]	L2 [mm]	e [mm]	r [mm]
40	32	733 808 009	0.060	80	37	50	64	30	11	2,3	3
50	40	733 808 010	0.067	90	43	61	67	30	12	2,9	3
63	50	733 808 011	0.159	105	54	76	74	30	14	3,6	4
75	65	733 808 012	0.219	125	70	90	78	30	16	4,3	4
90	80	733 808 013	0.314	140	82	108	87	35	17	5,1	4
110	100	733 808 014	0.465	160	105	131	102	41	18	6,3	4
140	125	733 808 016	0.862	190	130	165	124	47	18	8,0	4
160	150	733 808 017	1.176	215	158	188	149	52	18	9,1	4
225	200	733 808 020	2.484	270	206	248	180	55	24	12,8	4
280	250	733 808 022	2.230	325	259	308	240	63	25	15,9	4
315	300	733 808 023	2.450	375	308	346	272	66	25	17,9	4

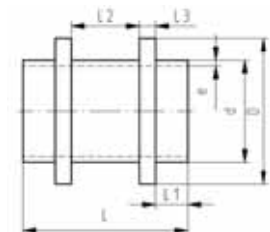

Fixed point fitting PE100 S5/SDR11

Model:

- Conventional butt-welding according to DVS 2207 part 1
- IR = Infrared-(IR Plus®) compatible. Choose fusion parameters: PE100
- Machined

d [mm]	FM	Code	kg	D [mm]	L [mm]	L1 [mm]	L2 [mm]	L3 [mm]	e [mm]
63	IR	753 665 558	0.182	90	122	30	42	10	5.8
75	IR	753 665 559	0.265	110	122	30	42	10	6.8
90	IR	753 665 560	0.357	125	122	30	42	10	8.2
110	IR	753 665 561	0.592	140	142	30	52	15	10.0
125	IR	753 665 562	0.811	160	152	35	52	15	11.4
140	IR	753 665 563	1.068	180	162	40	52	15	12.7
160	IR	753 665 564	1.349	200	162	40	52	15	14.6
180	IR	753 665 565	2.001	225	182	45	52	20	16.4
200	IR	753 665 566	2.469	250	182	45	52	20	18.2
225	IR	753 665 567	3.438	280	192	45	52	25	20.5
250	--	753 665 568	3.858	280	212	50	62	25	22.7
280	--	753 665 569	5.217	315	222	50	62	30	25.4
315	--	753 665 570	6.627	355	222	50	62	30	28.6
355	--	753 665 571	7.731	400	192	30	62	35	32.2

table continued next page

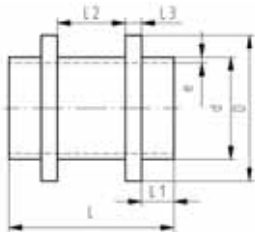

d [mm]	FM	Code	kg	D [mm]	L [mm]	L1 [mm]	L2 [mm]	L3 [mm]	e [mm]
400	--	753 665 572	10.890	450	212	30	72	40	36.3
450	--	753 665 573	14.775	500	232	35	72	45	40.9
500	--	753 665 574	20.268	560	252	40	72	50	45.4
560	--	753 665 575	28.608	630	282	45	82	55	50.8
630	--	753 665 576	39.129	710	302	50	82	60	57.2

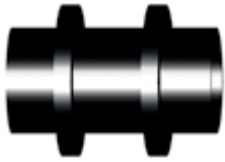

Fixed point fitting PE100 SDR17/17.6

Model:

- Conventional butt-welding according to DVS 2207 part 1
- IR = Infrared-(IR Plus®) compatible. Choose fusion parameters: PE100
- Machined

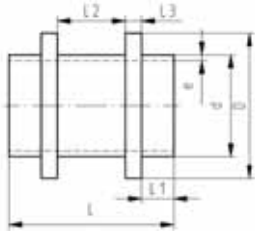

d [mm]	FM	Code	kg	D [mm]	L [mm]	L1 [mm]	L2 [mm]	L3 [mm]	e [mm]
63	IR	753 665 577	0.144	90	122	30	42	10	3.8
75	IR	753 665 578	0.212	110	122	30	42	10	4.5
90	IR	753 665 579	0.279	125	122	30	42	10	5.4
110	IR	753 665 580	0.457	140	142	30	52	15	6.6
125	IR	753 665 581	0.618	160	152	35	52	15	7.4
140	IR	753 665 582	0.815	180	162	40	52	15	8.3
160	IR	753 665 583	1.014	200	162	40	52	15	9.5
180	IR	753 665 584	1.528	225	182	45	52	20	10.7
200	IR	753 665 585	1.887	250	182	45	52	20	11.9
225	IR	753 665 586	2.661	280	192	45	52	25	13.4
250	--	753 665 587	2.796	280	212	50	62	25	14.8
280	--	753 665 588	3.829	315	222	50	62	30	16.6
315	--	753 665 589	4.871	355	222	50	62	30	18.7
355	--	753 665 590	5.812	400	192	30	62	35	21.1
400	--	753 665 591	8.180	450	212	30	72	40	23.7
450	--	753 665 592	11.015	500	232	35	72	45	26.7
500	--	753 665 593	15.251	560	252	40	72	50	29.7
560	--	753 665 594	0.000	630	282	45	82	55	33.2
630	--	753 665 595	29.574	710	302	50	82	60	37.4

27 70 04
27 70 05

Backing flange PP-V For butt fusion systems metric

Model:

- Modern full-plastic flange PP-GF (30 % glass-fibre reinforced)
- With V-groove which applies force evenly on collar
- With integrated bolt retainers as an assembly aid
- UV-resistant. Applicable for outside applications
- Connecting dimension: ISO 7005, EN 1092, BS 4504, DIN 2501
- **Bolt circle PN 10**

* Combined version, metric-ANSI

AL: number of holes

1) Suitable for socket- and butt fusion systems (no pictograph on flange)

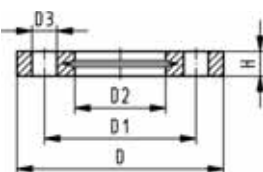

d [mm]	DN [mm]	PN	Code	kg	D [mm]	D1 [mm]	D2 [mm]	D3 [mm]	H [mm]	AL	SC
1) 20	15	16	727 700 406	0.093	95	65.0	28	14	16	4	M12
1) 25	20	16	727 700 407	0.120	105	75.0	34	14	17	4	M12
1) 32	25	16	727 700 408	0.151	115	85.0	42	14	18	4	M12
1) 40	32	16	727 700 409	0.244	140	100.0	51	18	20	4	M16
1) 50	40	16	727 700 410	0.297	150	110.0	62	18	22	4	M16
1) 63	50	16	727 700 411	0.362	165	125.0	78	18	24	4	M16
1) 75	65	16	727 700 412	0.487	185	145.0	92	18	26	4	M16
90	80	16	727 700 513	0.544	200	160.0	108	18	27	8	M16
110	100	16	727 700 514	0.643	220	180.0	128	18	28	8	M16
125	100	16	727 700 515	0.635	220	180.0	135	18	28	8	M16
140	125	16	727 700 516	0.842	250	210.0	158	18	30	8	M16
180	150	16	727 700 518	1.200	285	240.0	188	22	32	8	M20
250	250	16	727 700 521	2.052	395	350.0	288	22	38	12	M20
280	250	16	727 700 522	1.700	395	350.0	294	22	38	12	M20

table continued next page

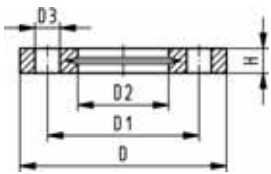

d [mm]	DN [mm]	PN	Code	kg	D [mm]	D1 [mm]	D2 [mm]	D3 [mm]	H [mm]	AL	SC
315	300	16	727 700 523	2.400	445	400.0	338	22	42	12	M20
355	350	10	727 700 524	4.440	515	460.0	376	22	46	16	M20
400	400	10	727 700 525	5.624	574	515.0	430	26	50	16	M24

27 70 14
27 70 15

Backing flange PP-V For butt fusion systems Inch ANSI

Model:

- Modern full-plastic flange PP-GF (30 % glass-fibre reinforced)
- With V-groove which applies force evenly on collar
- With integrated bolt-fixing as an assembly aid
- UV-resistant. Applicable for outside applications
- Connecting dimension: ANSI/ASME B 16.5 class 150, ASTM D 4024, BS 1560, BS EN 1759

• **Bolt circle class 150**

¹⁾ Suitable for socket- and butt fusion systems (no pictograph on flange)

AL: number of holes

* Combined version, metric-ANSI

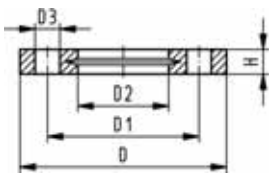

Inch	DN [mm]	d [mm]	PN	Code	kg	D [mm]	D1 [mm]	D2 [mm]	D3 [mm]	H [mm]	AL	SC
1/2	15	20	16	727 701 406	0.091	95	60.0	28	16	16	4	M12
3/4	20	25	16	727 701 407	0.120	105	70.0	34	16	17	4	M12
1	25	32	16	727 701 408	0.147	115	79.0	42	16	18	4	M12
1 1/4	32	40	16	727 701 409	0.246	140	89.0	51	16	20	4	M16
1 1/2	40	50	16	727 701 410	0.299	150	98.0	62	16	22	4	M16
2	50	63	16	727 701 411	0.361	165	121.0	78	19	24	4	M16
2 1/2	65	75	16	727 701 412	0.492	185	140.0	92	19	26	4	M16
3	80	90	16	727 701 513	0.607	200	152.0	108	19	27	4	M16
4	100	110	16	727 701 514	0.736	229	190.0	128	19	28	8	M16
10	250	250	16	727 701 521	2.241	406	362.0	288	26	38	12	M20
10	250	280	16	727 701 522	2.173	406	362.0	294	26	38	12	M20
12	300	315	16	727 701 523	3.627	483	432.0	338	26	42	12	M20

27 70 02
27 70 03

Backing flange PP-Steel For butt fusion systems metric

Model:

- Material: PP (30 % glass-fibre reinforced) with steel ring
 - UV-resistant. Applicable for outside applications
 - Connecting dimension: ISO 7005, EN 1092, BS 4504, DIN 2501
- **Bolt circle PN 10**

AL: number of holes

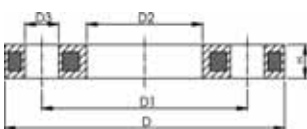

d [mm]	DN [mm]	PN	Code	kg	D [mm]	D1 [mm]	D2 [mm]	D3 [mm]	H [mm]	AL	SC
20	15	16	727 700 206	0.216	95	65	28	14	12	4	M12
25	20	16	727 700 207	0.279	105	75	34	14	12	4	M12
32	25	16	727 700 208	0.429	115	85	42	14	16	4	M12
40	32	16	727 700 209	0.621	140	100	51	18	16	4	M16
50	40	16	727 700 210	0.722	150	110	62	18	20	4	M16
63	50	16	727 700 211	1.084	165	125	78	18	20	4	M16
75	65	16	727 700 212	1.349	185	145	92	18	20	4	M16
90	80	16	727 700 313	1.390	200	160	108	18	20	8	M16
110	100	16	727 700 314	1.407	220	180	128	18	20	8	M16
125	100	16	727 700 315	1.408	220	180	135	18	20	8	M16
140	125	16	727 700 316	2.318	250	210	158	18	24	8	M16
180	150	16	727 700 318	3.108	285	240	188	22	24	8	M20
200	200	16	727 700 319	5.600	340	295	235	22	27	8	M20
225	200	16	727 700 320	5.533	340	295	238	22	27	8	M20
250	250	16	727 700 321	6.632	395	350	288	22	30	12	M20
280	250	16	727 700 322	6.573	395	350	294	22	30	12	M20

table continued next page

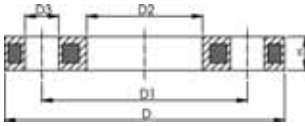

d [mm]	DN [mm]	PN	Code	kg	D [mm]	D1 [mm]	D2 [mm]	D3 [mm]	H [mm]	AL	SC
315	300	16	727 700 323	7.903	445	400	338	22	34	12	M20
355	350	16	727 700 324	14.587	515	460	376	22	40	16	M20
400	400	16	727 700 325	20.034	574	515	430	26	40	16	M24

24 70 04

Profiled backing flange PP/Steel For butt fusion systems metric



Model:

- PP with glass-fibre reinforcement and GGG 50 insert
- UV-resistant. Applicable for outside applications
- Connecting dimensions: ISO 7005, EN 1092, DIN 2501
- **Bolt circle PN 10**

Note:

flat side = bolt side
profiled side = flange adaptor side

AL: number of holes

* Galvanized steel, suitable for underground laying

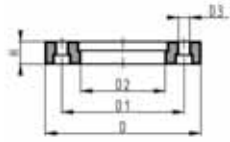
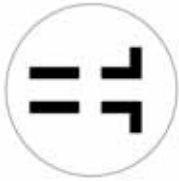

d [mm]	DN [mm]	PN	Code	kg	D [mm]	D1 [mm]	D2 [mm]	D3 [mm]	H [mm]	AL	SC
450	500	10	724 700 426	25.600	685	620	517	26	54	20	M24
500	500	10	724 700 427	21.061	685	620	533	26	54	20	M24
560	600	10	724 700 428	35.000	796	725	618	30	64	20	M27
630	600	10	724 700 429	32.500	800	725	645	30	58	20	M27
710	700	6	724 700 430	28.600	912	840	740	30	49	24	M27
800	800	6	724 700 431	39.300	1026	950	843	33	58	24	M30
900	900	6	724 700 432	48.500	1129	1050	947	33	62	28	M30

24 70 03

Profiled backing flange PP-Steel For butt fusion systems metric



Model:

- PP with glass-fibre reinforcement and GGG 50 insert
- UV-resistant. Applicable for outside applications
- Connecting dimensions: ISO 7005, EN 1092, DIN 2501
- **Bolt circle PN 16**

Note:

flat side = bolt side
profiled side = flange adaptor side

AL: number of holes

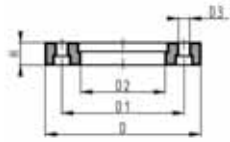

d [mm]	DN [mm]	PN	Code	kg	D [mm]	D1 [mm]	D2 [mm]	D3 [mm]	H [mm]	AL	SC
200	200	16	724 700 319	3.549	344	295	235	22	28	12	M20
225	200	16	724 700 320	3.380	344	295	238	22	28	12	M20
250	250	16	724 700 321	6.390	410	355	288	26	33	12	M24
280	250	16	724 700 322	6.310	410	355	294	26	33	12	M24
315	300	16	724 700 323	9.740	455	410	338	26	40	12	M24
355	350	16	724 700 324	15.203	521	470	376	26	50	16	M24
400	400	16	724 700 325	20.600	582	525	430	30	54	16	M27

01 48 04



Backing flange steel For butt fusion systems metric

Model:

- Galvanized steel, suitable for underground laying
- Connecting dimensions: ISO 7005, EN 1092, DIN 2501
- **Bolt circle PN 16**

AL: number of holes

d [mm]	DN [mm]	PN	Code	kg	D [mm]	D1 [mm]	D2 [mm]	D3 [mm]	H [mm]	AL	SC
32	25	16	701 474 390	0.830	115	85	42	14	12	4	M12
40	32	16	701 474 391	1.430	140	100	51	18	14	4	M16
50	40	16	701 474 392	1.530	150	110	62	18	14	4	M16
63	50	16	701 474 393	1.840	165	125	78	18	16	4	M16
75	65	16	701 474 394	2.150	185	145	92	18	16	8	M16
90	80	16	701 474 395	2.830	200	160	108	18	18	8	M16
110	100	16	701 474 396	3.300	220	180	128	18	18	8	M16
125	100	16	701 474 397	3.170	220	180	135	18	18	8	M16
125	125	16	701 474 386	3.500	250	210	135	18	25	8	M16
140	125	16	701 474 387	4.100	250	210	158	18	18	8	M16
160	150	16	701 474 382	5.440	285	240	178	22	20	8	M20
180	150	16	701 474 398	5.180	285	240	188	22	20	8	M20
200	200	16	701 480 475	8.000	340	295	235	22	24	12	M20
225	200	16	701 480 476	7.810	340	295	238	22	24	12	M20
250	250	16	701 480 477	8.120	405	355	288	26	30	12	M24
280	250	16	701 480 478	8.320	405	355	294	26	30	12	M24
315	300	16	701 480 479	9.850	460	410	338	26	34	12	M24
355	350	16	701 480 480	10.500	520	470	376	26	35	16	M24
400	400	16	701 480 481	24.400	580	525	430	30	38	16	M27
450	500	16	701 480 482	37.000	715	650	517	33	46	20	M30
500	500	16	701 480 483	32.000	715	650	533	33	46	20	M30

01 47 43

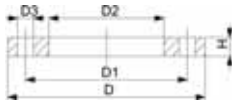

Backing flange steel For butt fusion systems metric

Model:

- Galvanized steel, suitable for underground laying
- Connecting dimensions: ISO 7005, EN 1092, DIN 2501
- **Bolt circle PN 10**

AL: number of holes

* Profiled version

d [mm]	DN [mm]	PN	Code	kg	D [mm]	D1 [mm]	D2 [mm]	D3 [mm]	H [mm]	AL	SC
200	200	10	701 474 383	6.630	340	295	235	22	20	8	M20
225	200	10	701 474 388	6.580	340	295	238	22	20	8	M20
250	250	10	701 474 399	9.090	395	350	288	22	22	12	M20
280	250	10	701 474 400	8.700	395	350	294	22	22	12	M20
315	300	10	701 474 401	12.500	445	400	338	22	26	12	M20
355	350	10	701 480 489	18.300	505	460	376	22	28	16	M20
400	400	10	701 480 490	24.400	565	515	430	26	32	16	M24
450	500	10	701 480 491	37.000	670	620	517	26	38	20	M24
500	500	10	701 480 492	32.000	670	620	533	26	38	20	M24
560	600	10	701 480 493	56.300	780	725	618	30	42	20	M27
630	600	10	701 480 494	47.200	780	725	645	30	42	20	M27

24 70 51

Profiled backing flange steel For butt fusion systems metric

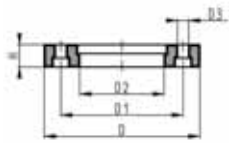

Model:

- Ductile iron (GGG40), epoxy coated (black)
- Connecting dimensions: ISO 7005, EN 1092, DIN 2501
- **Bolt circle PN 10**

Note:

flat side = bolt side
profiled side = flange adaptor side

AL: number of holes

* Galvanized steel, suitable for underground laying

d [mm]	DN [mm]	PN	Code	kg	D [mm]	D1 [mm]	D2 [mm]	D3 [mm]	H [mm]	AL	SC
* 450	450	10	724 705 026	22.600	615	565	470	26	44	20	M24
710	700	6	724 705 130	36.400	900	840	740	30	45	24	M27
800	800	6	724 705 131	50.500	1015	950	843	33	53	24	M30
900	900	6	724 705 132	55.800	1115	1050	947	33	56	28	M30
1000	1000	6	724 705 133	71.100	1230	1160	1050	36	62	28	M33
1200	1200	4	724 705 134	101.000	1455	1380	1260	39	68	32	M36

EPDM 48 40 03

Flat gasket



Model:

- For all metric GF Flange Adaptors
 - Hardness approx. 65° Shore
 - Integrated fixation aids from d110
 - Centering on the inner diameter of the screw crown
- di FA are the suitable inner diameters of flange adaptors

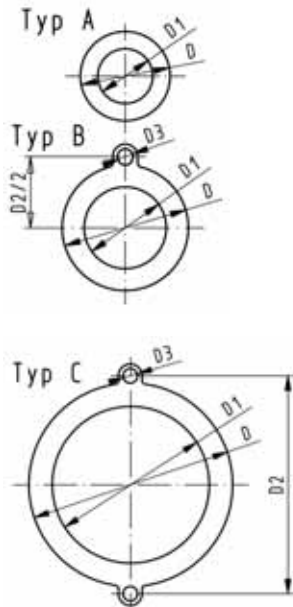

d [mm]	DN [mm]	PN	Type	EPDM Code	kg	D [mm]	D1 [mm]	D2 [mm]	D3 [mm]	H [mm]	di FA [mm]
16	10	10	A	748 400 305	0.004	46	16			2	6 - 26
20	15	10	A	748 400 306	0.012	51	20			2	10 - 30
25	20	10	A	748 400 307	0.004	61	25			2	15 - 35
32	25	10	A	748 400 308	0.008	71	32			2	22 - 42
40	32	10	A	748 400 309	0.013	82	40			3	30 - 50
50	40	10	A	748 400 310	0.016	92	50			3	40 - 60
63	50	10	A	748 400 311	0.018	107	63			3	53 - 73
75	65	10	A	748 400 312	0.029	127	71			3	61 - 81
90	80	10	A	748 400 313	0.035	142	84			3	74 - 94
110	100	10	B	748 400 314	0.051	162	104	180	18	4	94 - 114
125	100	10	B	748 400 315	0.044	162	119	180	18	4	109 - 129
140	125	10	B	748 400 316	0.068	192	134	210	18	4	124 - 144
160 / 180	150	10	B	748 400 317	0.090	218	155	241	22	4	145 - 165
200	200	6	C	748 400 319	0.210	273	195	295	22	5	185 - 205
225	200	6	C	748 400 320	0.140	273	216	295	22	5	206 - 226
250	250	6	C	748 400 321	0.210	328	250	350	22	5	240 - 260
280	250	6	C	748 400 322	0.151	328	273	350	22	5	263 - 283
315	300	6	C	748 400 323	0.237	378	305	400	22	5	295 - 315

EPDM 48 44 07
FPM 49 44 07

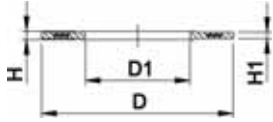

Profile flange gasket metric

Model:

- For all metric GF Flange Adaptors
- Profile Gasket with steel insert (type G-ST-P/K)
- Hardness: 70° Shore **EPDM**, 75° Shore **FPM**
- **EPDM**: approved acc. to DVGW W 270, KTW recommendation
- Centering on the inner diameter of the screw crown
- material steel insert: carbon steel

di FA are the suitable inner diameters of flange adaptors

d [mm]	DN [mm]	PN	EPDM Code	FPM Code	kg	D [mm]	D1 [mm]	H [mm]	H1 [mm]	di FA [mm]
16	10	16	748 440 705	749 440 705	0.012	46	16	4	3	6 - 16
20	15	16	748 440 706	749 440 706	0.013	51	20	4	3	10 - 20
25	20	16	748 440 707	749 440 707	0.014	61	22	4	3	12 - 22
32	25	16	748 440 708	749 440 708	0.019	71	28	4	3	18 - 28
40	32	16	748 440 709	749 440 709	0.026	82	40	4	3	30 - 40
50	40	16	748 440 710	749 440 710	0.039	92	46	4	3	36 - 46
63	50	16	748 440 711	749 440 711	0.050	107	58	5	4	48 - 58
75	65	16	748 440 712	749 440 712	0.082	127	69	5	4	59 - 69
90	80	16	748 440 713	749 440 713	0.083	142	84	5	4	73 - 84
110	100	16	748 440 714	749 440 714	0.127	162	104	6	5	94 - 104
125	100	16	748 440 715	749 440 715	0.105	162	123	6	5	113 - 123
140	125	16	748 440 716	749 440 716	0.173	192	137	6	5	127 - 137
160 / 180	150	16	748 440 717	749 440 717	0.207	218	160	8	6	150 - 160
200	200	16	748 440 719	749 440 719	0.263	273	203	8	6	192 - 203
225	200	16	748 440 720	749 440 720	0.255	273	220	8	6	207 - 220
250	250	16	748 440 721	749 440 721	0.482	328	252	8	6	238 - 252
280	250	16	748 440 722	749 440 722	0.323	328	274	8	6	264 - 274
315	300	16	748 440 723	749 440 723	0.549	378	306	8	6	296 - 306
355	350	16	748 440 724	749 440 724	0.870	438	355	10	7	340 - 355
400	400	16	748 440 725	749 440 725	1.088	489	400	10	7	385 - 400
450	500	16	748 440 726	749 440 726	0.718	594	403	10	7	393 - 403
500	500	16	748 440 727	749 440 727	0.718	594	447	10	7	437 - 447
560	600	16	748 440 728	749 440 728	0.923	695	494	10	7	484 - 494
630	600	16	748 440 729	749 440 729	0.923	695	555	10	7	545 - 555

45 44 07

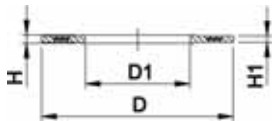

Profile flange gasket metric

Model:

- For all metric GF Flange Adaptors
- Profile Gasket with steel insert (type G-ST-P/K)
- material steel insert: carbon steel
- NBR/DUO = Nitrile rubber, hardness approx. 80° Shore
- Suitable for drinking water and gas applications
- Approved acc. to DVGW standard DIN EN 682
- Approved acc. to DVGW W 270, KTW recommendation
- d corresponds to the centring at the inner diameter of the screw crown

di FA are the suitable inner diameters of flange adaptors

d [mm]	DN [mm]	PN	NBR/DUO Code	kg	D [mm]	D1 [mm]	H [mm]	H1 [mm]	di FA [mm]
20	15	16	745 440 706	0.009	51	20	4	3	10 - 20
25	20	16	745 440 707	0.012	61	22	4	3	12 - 22
32	25	16	745 440 708	0.018	71	28	4	3	18 - 28
40	32	16	745 440 709	0.021	82	40	4	3	30 - 40
50	40	16	745 440 710	0.029	92	46	4	3	36 - 46
63	50	16	745 440 711	0.039	107	58	5	4	48 - 58
75	65	16	745 440 712	0.058	127	69	5	4	59 - 69
90	80	16	745 440 713	0.061	142	84	5	4	73 - 84
110	100	16	745 440 714	0.096	162	104	6	5	94 - 104
125	100	16	745 440 715	0.073	162	123	6	5	113 - 123
140	125	16	745 440 716	0.127	192	137	6	5	127 - 137
160 / 180	150	16	745 440 717	0.145	218	160	8	6	150 - 160
200	200	16	745 440 719	0.295	273	203	8	6	192 - 203
225	200	16	745 440 720	0.183	273	220	8	6	207 - 220
250	250	16	745 440 721	0.355	328	252	8	6	238 - 252

table continued next page

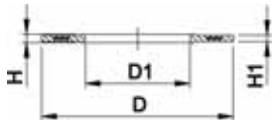

d [mm]	DN [mm]	PN	NBR/DUO Code	kg	D [mm]	D1 [mm]	H [mm]	H1 [mm]	di FA [mm]
280	250	16	745 440 722	0.229	328	274	8	6	264 - 274
315	300	16	745 440 723	0.419	378	306	8	6	296 - 306
355	350	16	745 440 724	0.645	438	355	10	7	340 - 355
400	400	16	745 440 725	0.819	489	400	10	7	385 - 400
450	500	16	745 440 726	1.885	594	403	10	7	393 - 403
500	500	16	745 440 727	1.618	594	447	10	7	437 - 447
560	600	16	745 440 728	2.281	695	494	10	7	484 - 494
630	600	16	745 440 729	2.000	695	555	10	7	545 - 555

48 40 03

Flat gasket for flange adaptor

Model:

- Hardness : EPDM ca. 70° Shore
- Flange bolt circle: PN10
- Integrated fixation aids
- Centering on the inner diameter of the screw crown

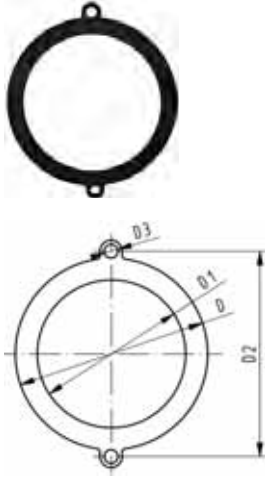

d [mm]	DN [mm]	PN* [bar]	EPDM Code	kg	D [mm]	D1 [mm]	D2 [mm]	D3 [mm]	H [mm]
710	700	6	748 400 330	0.900	810	625	840	30	5
800	800	6	748 400 331	1.000	917	705	950	33	5
900	900	6	748 400 332	1.200	1014	805	1050	36	5
1000	1000	6	748 400 333	1.400	1121	890	1160	39	5

Electrofusion Fittings

53 91 16

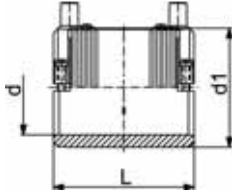

Coupler With integral pipe fixation

- PE 100 SDR 11 (ISO S5)
- 10 bar Gas / 16 bar Water
- 4 mm pin connectors
- Limited path fusion indicators
- Removable centre stop

d [mm]	Code	kg	d1 [mm]	L [mm]
20	753 911 606	0.053	31	70
25	753 911 607	0.050	36	70
32	753 911 608	0.071	44	72
40	753 911 609	0.095	54	80
50	753 911 610	0.131	66	88
63	753 911 611	0.194	81	96

53 91 16

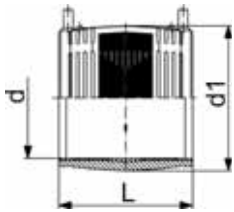

Coupler

- PE 100 SDR 11 (ISO S5)
- 10 bar Gas / 16 bar Water
- 4 mm pin connectors
- Limited path fusion indicators
- Removable centre stop up to d160

d [mm]	Code	kg	d1 [mm]	L [mm]
75	753 911 612	0.282	96	110
90	753 911 613	0.406	113	125
110	753 911 614	0.692	138	145
125	753 911 615	0.718	154	156
140	753 911 616	0.945	172	166
160	753 911 617	1.362	196	180
180	753 911 618	1.747	219	192
200	753 911 619	1.866	244	208
225	753 911 620	3.329	273	225
250	753 911 621	4.678	304	248
280	753 911 622	5.647	340	252
315	753 911 623	8.142	382	267
355	753 911 624	13.098	432	290
400	753 911 625	18.320	487	290

53 91 16

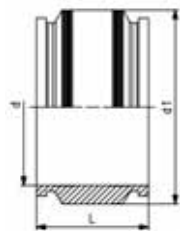

Coupler

- PE 100 SDR 11 (ISO S5)
- 16 bar Water
- Only for water applications
- 4 mm pin connectors
- Limited path fusion indicators

d [mm]	Code	kg	d1 [mm]	L [mm]
450	753 911 646	20.675	559	320
500	753 911 647	28.403	621	360
560	753 911 648	39.503	694	390
630	753 911 649	55.641	780	430

53 91 16



Coupler

- PE 100 SDR 11 (ISO S5)
- 16 bar Water
- Only for water applications
- 4 mm pin connectors

d [mm]	Code	kg	d1 [mm]	L [mm]
710	753 911 650	72.450	878	475
800	753 911 651	102.490	988	520
900	753 911 652	137.930	1110	550

53 91 18

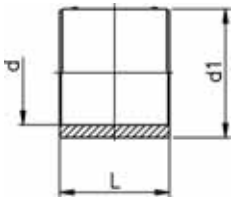

Coupler

- PE 100 SDR 17 (ISO S8)
- 5 bar Gas / 10 bar Water
- 4 mm pin connectors
- Limited path fusion indicators
- d160 with removable centre stop

d [mm]	Code	kg	d1 [mm]	L [mm]
160	753 911 817	1.017	186	180
180	753 911 818	1.434	213	192
200	753 911 819	1.726	233	206
225	753 911 820	2.545	261	225
250	753 911 821	4.616	304	248
280	753 911 822	5.606	304	252
315	753 911 823	8.186	382	267
355	753 911 824	9.522	414	290
400	753 911 825	18.000	487	290
450	753 911 826	16.000	522	313
500	753 911 827	22.000	579	343

53 91 18



Coupler

- PE 100 SDR 17 (ISO S8)
- 10 bar water
- Only for water applications
- 4 mm pin connectors

d [mm]	Code	kg	d1 [mm]	L [mm]
710	753 911 850	49.370	814	475
800	753 911 851	69.180	916	520
900	753 911 852	93.150	1030	550
1000	753 911 853	125.650	1143	600
1200	753 911 854	196.450	1370	650

53 10 16

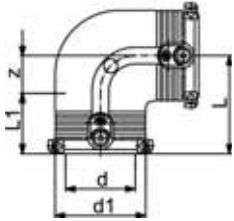

Elbow 90° With integral pipe fixation

- PE 100 SDR 11 (ISO S5)
- 10 bar Gas / 16 bar Water
- 4 mm pin connectors
- Limited path fusion indicators

d [mm]	Code	kg	d1 [mm]	L [mm]	L1 [mm]	z [mm]
20	753 101 606	0.080	35	54	34	20
25	753 101 607	0.068	35	54	34	20
32	753 101 608	0.098	44	53	36	17
40	753 101 609	0.141	54	62	39	23
50	753 101 610	0.200	66	71	43	28
63	753 101 611	0.318	81	81	48	32

53 10 18

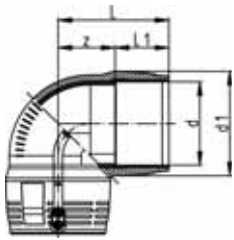

Elbow 90°

- PE 100 SDR 11 (ISO S5)
- 10 bar Gas / 16 bar Water
- 4 mm pin connectors
- Limited path fusion indicators

d [mm]	Code	kg	d1 [mm]	L [mm]	L1 [mm]	z [mm]
75	753 101 612	0.415	97	94	54	40
90	753 101 813	0.828	115	122	62	60
110	753 101 814	1.224	140	147	72	76
125	753 101 815	1.742	160	142	74	68
160	753 101 817	3.830	196	178	92	86
180	753 101 818	5.410	219	195	95	100

53 10 18

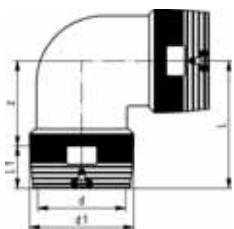

Elbow 90°

- PE 100 SDR 11 (ISO S5)
- 10 bar Gas / 16 bar Water
- 4 mm pin connectors
- Limited path fusion indicators
- Two separate fusion zones

d [mm]	Code	kg	d1 [mm]	L [mm]	L1 [mm]	z [mm]
200	753 101 819	9.320	250	298	104	194
225	753 101 820	13.220	280	318	112	206
250	753 101 821	16.600	310	347	123	224

53 15 16

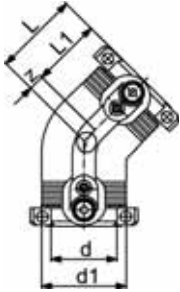

Elbow 45° With integral pipe fixation

- PE 100 SDR 11 (ISO S5)
- 10 bar Gas / 16 bar Water
- 4 mm pin connectors
- Limited path fusion indicators

d [mm]	Code	kg	d1 [mm]	L [mm]	L1 [mm]	z [mm]
40	753 151 609	0.106	54	50	39	11
50	753 151 610	0.171	66	56	43	13
63	753 151 611	0.252	81	63	48	15

53 15 18



Elbow 45°

- PE 100 SDR 11 (ISO S5)
- 10 bar Gas / 16 bar Water
- 4 mm pin connectors
- Limited path fusion indicators

d [mm]	Code	kg	d1 [mm]	L [mm]	L1 [mm]	z [mm]
90	753 151 813	0.583	115	91	62	29
110	753 151 814	0.985	140	112	72	40
125	753 151 815	1.438	160	127	78	49
160	753 151 817	3.055	196	134	92	42
180	753 151 818	4.037	217	142	95	47

53 15 18

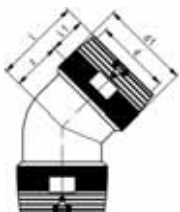

Elbow 45°

- PE 100 SDR 11 (ISO S5)
- 10 bar Gas / 16 bar Water
- 4 mm pin connectors
- Limited path fusion indicators
- Two separate fusion zones

d [mm]	Code	kg	d1 [mm]	L [mm]	L1 [mm]	z [mm]
200	753 151 819	7.566	250	232	104	128
225	753 151 820	11.300	280	247	112	135
250	753 151 821	13.500	310	275	123	152

53 21 16

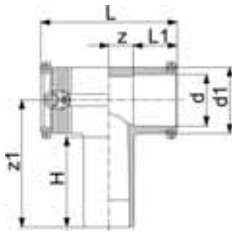

Tee 90°, equal with Integral Clamp

- PE 100 SDR 11 (ISO S5)
- 10 bar Gas / 16 bar Water
- 4 mm pin connectors
- Limited path fusion indicators

d [mm]	Code	kg	d1 [mm]	L [mm]	L1 [mm]	z [mm]	z1 [mm]	H [mm]
20	753 211 606	0.085	35	88	32	11	92	67
25	753 211 607	0.075	35	90	32	11	92	70
32	753 211 608	0.118	44	102	34	15	100	74
40	753 211 609	0.175	54	119	39	21	114	82
50	753 211 610	0.252	66	135	42	24	126	90
63	753 211 611	0.407	81	151	46	28	150	102

53 20 18



Tee 90° equal

- PE 100 SDR 11 (ISO S5)
- 10 bar Gas / 16 bar Water
- 4 mm pin connectors
- Limited path fusion indicators

d [mm]	Code	kg	d1 [mm]	L [mm]	L1 [mm]	z [mm]	z1 [mm]	H [mm]
75	753 211 612	0.569	97	178	54	35	143	87
90	753 201 813	0.891	115	205	62	41	161	94
110	753 201 814	1.576	140	255	72	56	184	104
125	753 201 815	2.212	161	276	78	60	207	113
160	753 201 817	4.386	196	325	92	71	206	103
180	753 201 818	6.796	225	344	90	82	250	110

53 20 18

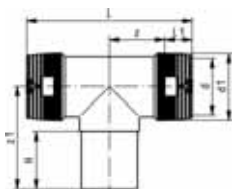

Tee 90°, equal

- PE 100 SDR 11 (ISO S5)
- 10 bar Gas / 16 bar Water
- 4 mm pin connectors
- Limited path fusion indicators
- Two separate fusion zones

d [mm]	Code	kg	d1 [mm]	L [mm]	L1 [mm]	z [mm]	z1 [mm]	H [mm]
200	753 201 819	10.800	250	590	104	191.0	250	117
225	753 201 820	15.900	280	636	112	206.0	270	122
250	753 201 821	18.900	310	685	123	219.5	288	127

93 28 10

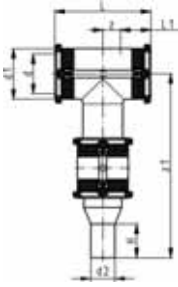

Tee 90°, reduced (Kit)

- PE 100 SDR 11 (ISO S5)
- 10 bar Gas / 16 bar Water
- Integral pipe fixation (up to d63)
- 4 mm pin connectors
- Limited path fusion indicators
- Supplied as kit including ELGEF® Plus Coupler and Spigot Reducer

d [mm]	d2 [mm]	Code	kg	d1 [mm]	L [mm]	L1 [mm]	z [mm]	z1 [mm]	H [mm]
40	20	193 281 004	0.314	54	120	39	21	244	212
40	25	193 281 005	0.319	54	120	39	21	244	212
75	40	193 280 998	1.060	97	187	61	33	296	248
90	50	193 280 999	1.655	112	202	61	41	336	274
110	63	193 280 961	2.812	136	242	65	56	366	293
125	63	193 280 963	3.673	151	256	75	53	361	279
125	110	193 280 965	3.920	151	256	75	53	389	307
180	90	193 281 032	10.891	225	344	90	82	487	347
180	110	193 281 033	10.465	225	344	90	82	495	355

53 21 10



Tee 90°, reduced

- PE 100 SDR 11 (ISO S5)
- 10 bar Gas / 16 bar Water
- 4 mm pin connectors
- Limited path fusion indicators
- Two separate fusion zones

d [mm]	d2 [mm]	Code	kg	d1 [mm]	L [mm]	L1 [mm]	z [mm]	z1 [mm]	H [mm]
160	63	753 211 037	5.660	200	433	90	126.5	176	65
160	90	753 211 039	5.508	200	496	90	158.0	188	79
160	110	753 211 040	5.157	200	496	90	158.0	195	85
200	90	753 211 059	9.012	250	596	104	194.0	215	81
200	110	753 211 060	12.400	250	596	104	194.0	218	84
200	160	753 211 063	12.400	250	596	104	194.0	236	101
225	90	753 211 069	13.100	280	658	112	217.0	226	80
225	110	753 211 070	13.100	280	658	112	217.0	235	85
225	160	753 211 073	13.600	280	658	112	217.0	255	105
250	110	753 211 080	11.660	310	685	123	219.5	245	85
250	160	753 211 083	11.660	310	685	123	219.5	264	101

53 20 16

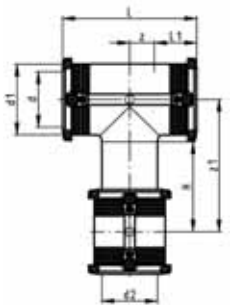

Tee 90° with weldable outlet (Kit)

- PE 100 SDR 11 (ISO S5)
- 10 bar Gas / 16 bar Water
- Integral pipe fixation (up to d63)
- 4 mm pin connectors
- Limited path fusion indicators
- Supplied as kit including ELGEF® Plus Coupler or ELGEF® Plus Reducer

d [mm]	d2 [mm]	Code	kg	d1 [mm]	L [mm]	L1 [mm]	z [mm]	z1 [mm]	H [mm]
20	20	753 201 606	0.161	35	90	34	11	92	67
25	25	753 201 607	0.122	35	90	34	11	92	70
32	32	753 201 608	0.201	44	102	36	15	100	74
40	32	193 281 006	0.288	54	120	39	21	127	95
40	40	753 201 609	0.285	54	120	39	21	114	82
50	32	193 281 007	0.364	66	135	43	24	144	108
50	40	193 281 008	0.407	66	135	43	24	140	104
50	50	753 201 610	0.389	66	135	43	24	126	90
63	32	193 280 997	0.550	81	152	48	28	173	125
63	40	193 281 009	0.566	81	152	48	28	169	121
63	50	193 281 010	0.628	81	152	48	28	165	117
63	63	753 201 611	0.615	81	152	48	28	150	102
90	63	193 281 011	1.311	112	202	61	41	182	120
90	90	753 201 613	1.342	112	202	61	41	146	84
110	90	193 281 012	2.343	136	242	65	56	200	127
110	110	753 201 614	2.329	136	242	65	56	161	88

table continued next page

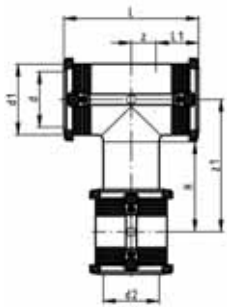

d [mm]	d2 [mm]	Code	kg	d1 [mm]	L [mm]	L1 [mm]	z [mm]	z1 [mm]	H [mm]
125	90	193 281 013	3.146	151	256	75	53	214	132
125	125	753 201 615	2.960	151	256	75	53	174	92
160	110	193 281 030	7.443	196	325	92	71	271	168
160	160	753 201 617	6.359	196	325	92	71	206	103
180	125	193 281 031	9.654	225	344	90	82	330	190
180	180	753 201 618	8.561	225	344	90	82	250	110

53 90 16

Reducer with Integral Clamp

- PE 100 SDR 11 (ISO S5)
- 10 bar Gas / 16 bar Water
- 4 mm pin connectors
- Limited path fusion indicators

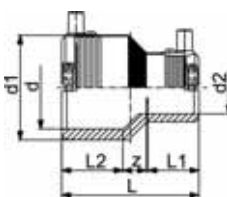

d [mm]	d2 [mm]	Code	kg	d1 [mm]	L [mm]	L1 [mm]	L2 [mm]	z [mm]
25	20	753 901 639	0.051	35	74	34	34	6
32	20	753 901 640	0.056	44	79	33	36	10
32	25	753 901 641	0.062	44	79	33	36	10
40	20	753 901 644	0.069	54	88	33	39	15
40	25	753 901 645	0.084	54	88	33	39	15
40	32	753 901 646	0.095	54	88	33	39	13
50	32	753 901 651	0.124	66	96	35	43	18
50	40	753 901 652	0.119	66	96	39	43	14
63	32	753 901 656	0.158	81	105	35	48	23
63	40	753 901 657	0.176	81	105	39	48	19
63	50	753 901 658	0.176	81	105	43	48	15

53 90 18

Reducer

- PE 100 SDR 11 (ISO S5)
- 10 bar Gas / 16 bar Water
- 4 mm pin connectors
- Limited path fusion indicators

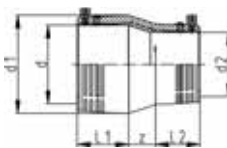

d [mm]	d2 [mm]	Code	kg	d1 [mm]	L [mm]	L1 [mm]	L2 [mm]	z [mm]
90	63	753 901 831	0.385	113	146	63	47	36
110	90	753 901 833	0.700	138	173	73	63	38
125	90	753 901 836	0.891	152	180	79	61	40
160	110	753 901 834	1.641	196	226	91	70	65
180	125	753 901 835	1.962	220	247	97	70	80

53 90 18

Reducer

- PE 100 SDR 11 (ISO S5)
- 10 bar Gas / 16 bar Water
- 4 mm pin connectors
- Limited path fusion indicators
- Two separate fusion zones

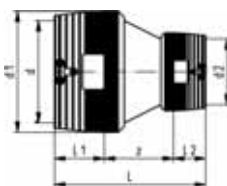

d [mm]	d2 [mm]	Code	kg	d1 [mm]	L [mm]	L1 [mm]	L2 [mm]	z [mm]
200	160	753 901 837	5.098	250	365	104	90	171
225	160	753 901 838	6.000	280	385	112	90	183
250	160	753 901 840	7.860	310	400	123	90	187
250	200	753 901 841	8.480	310	427	123	104	200

93 28 09

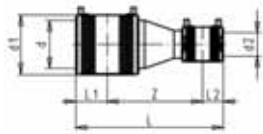

Reducer (Kit)

- PE 100 SDR 11 (ISO S5)
- 10 bar Gas / 16 bar Water
- Integral pipe fixation (up to d63)
- 4 mm pin connectors
- Limited path fusion indicators
- Supplied as kit including ELGEF® Plus Coupler and Spigot Reducer

d [mm]	d2 [mm]	Code	kg	d1 [mm]	L [mm]	L1 [mm]	L2 [mm]	z [mm]
75	40	193 280 992	0.574	96	265	55	40	170
75	50	193 280 993	0.623	96	269	55	44	170
75	63	193 280 994	0.700	96	273	55	48	170
90	50	193 280 958	0.857	113	297	63	44	190
90	75	193 280 995	1.071	113	308	63	55	190
110	63	193 280 950	1.389	138	326	73	48	205
110	75	193 280 996	1.496	138	333	73	55	205
125	63	193 280 953	1.567	154	314	79	48	187
125	110	193 280 951	2.098	154	367	79	73	215
160	90	193 280 954	3.060	196	370	90	63	217
160	125	193 280 952	3.252	196	414	90	79	245
180	110	193 280 959	4.167	214	413	95	73	245

53 96 16

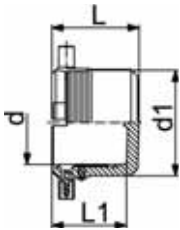

End Cap with integral pipe fixation

- PE 100 SDR 11 (ISO S5)
- 10 bar Gas / 16 bar Water
- 4 mm pin connectors
- Limited path fusion indicators

d [mm]	Code	kg	d1 [mm]	L [mm]	L1 [mm]
20	753 961 606	0.041	35	52	44
25	753 961 607	0.046	35	52	44
32	753 961 608	0.058	44	52	44
40	753 961 609	0.064	54	56	47
50	753 961 610	0.154	66	60	49
63	753 961 611	0.142	81	66	54

53 96 17

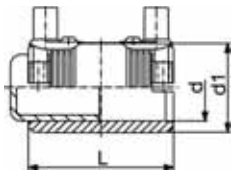

End cap (Kit)

- PE 100 SDR 11 (ISO S5)
- 10 bar Gas / 16 bar Water
- 4 mm pin connectors
- Limited path fusion indicators
- Supplied as kit including ELGEF Plus Coupler

d [mm]	Code	kg	d1 [mm]	L [mm]
75	753 961 712	0.446	96	110
90	753 961 713	0.663	113	125
110	753 961 714	1.090	133	145
125	753 961 715	1.345	155	158
140	753 961 716	2.250	175	170
160	753 961 717	2.382	197	180
180	753 961 718	3.098	220	194
200	753 961 719	4.180	245	208
225	753 961 720	5.852	296	224

53 96 16

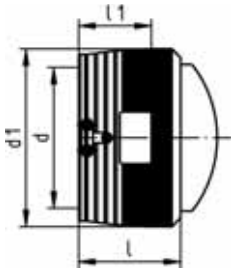

End Cap

- PE 100 SDR 11 (ISO S5)
- 10 bar Gas / 16 bar Water
- 4 mm pin connectors
- Limited path fusion indicators

d [mm]	Code	kg	d1 [mm]	L [mm]	L1 [mm]
160	753 961 617	1.782	200	143	90
200	753 961 619	3.585	250	162	104
225	753 961 620	4.500	280	170	112
250	753 961 621	6.300	310	185	123

73 28 19

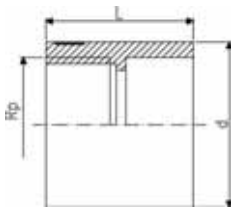

PE Adaptor Female thread

- PE 80 SDR 11 (ISO S5)
- 5 bar Gas / 12,5 bar Water
- Connection to plastic or metal
- Reinforcing ring stainless (A2)
- For ELGEF Plus Branch Saddle (53 131 000) d63 - 400mm, pipe SDR 11, d75 - 400mm, pipe SDR 17
- Parallel female thread
- *PE 100 SDR 11 (ISO S5)

d [mm]	Rp [inch]	Code	kg	L [mm]
63	1 ½	173 281 925	0.088	54

51 336 001

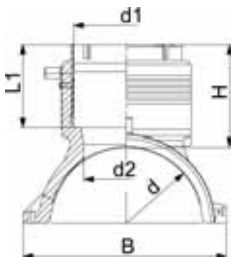

Branch saddle outlet 90 - 125 mm

- PE 100 SDR 11 (ISO S5)
- 10 bar Gas / 16 bar Water
- Branch Saddle complete, incl. lower part and 3 screws
- Additional fixing with snatch hinge
- Electrofusion outlet with integrated pipe fixation
- Protected wire without medium contact
- 4 mm pin connectors
- Limited path fusion indicators
- * Delivered without lower part. Pipe fixation with multiple use assembly tool no. 193 281 027

d [mm]	d1 [mm]	Code	kg	H [mm]	L [mm]	L1 [mm]	B [mm]	d2 [mm]
110	90	193 135 009	1.124	101	220	82	164	65
110	110	193 135 010	1.224	107	220	88	164	65
125	90	193 135 019	1.134	101	220	82	179	65
125	110	193 135 020	1.290	107	220	88	179	65
* 140	90	193 135 029	0.982	101	220	81	195	65
* 140	110	193 135 030	1.087	107	220	87	195	65
160	90	193 135 039	1.449	102	240	82	215	65
160	110	193 135 040	1.582	108	240	88	215	86
160	125	193 135 041	1.782	129	240	99	215	86

table continued next page

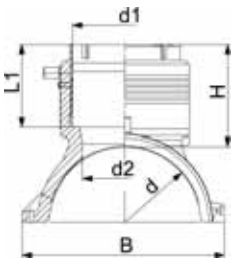

d [mm]	d1 [mm]	Code	kg	H [mm]	L [mm]	L1 [mm]	B [mm]	d2 [mm]
180	90	193 135 049	1.672	102	260	82	237	65
180	110	193 135 050	1.765	108	260	88	237	86
180	125	193 135 051	2.015	129	260	99	237	86
200	90	193 135 059	1.803	102	260	82	253	65
200	110	193 135 060	1.963	108	260	88	253	86
200	125	193 135 061	2.128	129	260	99	253	86
225	90	193 135 069	2.006	102	260	82	287	65
225	110	193 135 070	2.040	108	260	88	287	86
225	125	193 135 071	2.312	129	260	99	287	86
250	90	193 135 079	2.145	102	260	82	312	65
250	110	193 135 080	2.258	108	260	88	312	86
250	125	193 135 081	2.500	129	260	99	312	86

51 336 001

Branch saddle topload outlet 90 - 125 mm



- PE 100 SDR 11 (ISO S5)
- 10 bar Gas / 16 bar Water
- Branch Saddle for assembling as Topload with tool 799.350.477; angle adaptors (799.350.340) for fusion cable required
- Electrofusion outlet with integrated pipe fixation
- Protected wire without medium contact
- 4 mm pin connectors
- Limited path fusion indicators

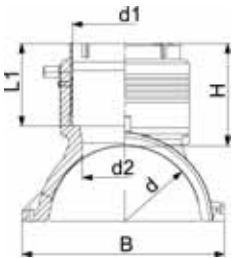

d [mm]	d1 [mm]	Code	kg	H [mm]	L [mm]	L1 [mm]	B [mm]	d2 [mm]
280	90	193 135 289	1.242	102	260	82	243	65
280	110	193 135 290	1.295	108	260	88	243	86
280	125	193 135 291	1.530	129	260	99	243	86
315 - 355	90	193 135 309	1.214	102	260	82	249	65
315 - 355	110	193 135 310	1.297	108	260	88	249	86
315 - 355	125	193 135 311	1.530	129	260	99	249	86
400 - 450	90	193 135 329	1.039	102	260	82	256	65
400 - 450	110	193 135 330	1.116	108	260	88	256	86
400 - 450	125	193 135 331	1.369	129	260	99	256	86
500 - 630	90	193 135 159	1.086	102	260	82	263	65
500 - 630	110	193 135 160	1.159	108	260	88	263	86
500 - 630	125	193 135 161	1.388	129	260	99	263	86

51 336 001

Branch saddle topload outlet 160 - 225 mm



- PE 100 SDR 11 (ISO S5)
- 10 bar Gas / 16 bar Water
- Branch Saddle installation only with installation set Topload TL225 (799.300.807); angle adaptors (799.350.340) for fusion cable required
- 4 mm pin connectors
- Limited path fusion indicators
- Protected wire without medium contact
- Spigot outlet for butt- and electrofusion
- Full pressure applicable - no derating factor

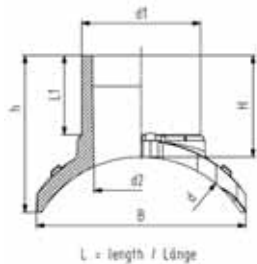

d [mm]	d1 [mm]	Code	kg	h [mm]	H [mm]	L [mm]	L1 [mm]	B [mm]	d2 [mm]
315	160	193 135 402	2.662	212	137	322	110	282	131
315	225	193 135 404	4.594	306	160	366	127	260	184
355	160	193 135 412	2.662	206	137	322	110	282	131
355	225	193 135 414	4.710	319	160	366	127	249	184
400	160	193 135 422	2.678	198	137	322	110	300	131
400	225	193 135 424	4.700	329	160	366	127	241	184
450	160	193 135 432	2.678	194	137	322	110	300	131
450	225	193 135 434	4.700	329	160	366	127	233	184
500	160	193 135 442	2.708	186	137	322	110	310	131
500	225	193 135 444	4.650	344	160	366	127	226	184
560	160	193 135 452	2.708	183	137	322	110	310	131

table continued next page



d [mm]	d1 [mm]	Code	kg	h [mm]	H [mm]	L [mm]	L1 [mm]	B [mm]	d2 [mm]
560	225	193 135 454	4.650	344	160	366	127	220	184
630	160	193 135 462	2.500	177	137	322	110	312	131
630	225	193 135 464	4.630	353	160	366	127	214	184
710	160	193 135 472	2.500	172	137	322	110	312	131
710	225	193 135 474	4.630	352	160	366	127	208	184
800	160	193 135 482	2.500	168	137	322	110	312	131
800	225	193 135 484	4.610	359	160	366	127	203	184
900	225	193 135 494	4.610	359	160	366	127	199	184
1000	225	193 135 504	4.610	359	160	366	127	195	184

53 131 000



Electrofusion saddle

- PE 100 SDR 11 (ISO S5)
- 10 bar Gas / 16 bar Water
- Complete with lower part
- ***Complete with moulded-on lower part
- 4 mm pin connectors
- Limited path fusion indicators

*not suitable for all tapping-tees, tapping-valves and spigots with cutter of the modular systems

** = not suitable for all tapping-tees, tapping-valves and spigots with cutter of the modular systems / delivery without lower part for assembling as Top load with tool 799.350.475

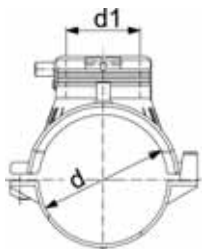

L = length / Länge

d [mm]	d1 [mm]	Code	kg	L [mm]
63	63	193 131 037	0.325	165
75	63	193 131 047	0.455	165
90	63	193 131 057	0.412	165
110	63	193 131 067	0.458	165
125	63	193 131 077	0.502	165
140	63	193 131 087	0.523	165
160	63	193 131 097	0.493	165
180	63	193 131 107	0.600	165
200	63	193 131 117	0.634	165
225	63	193 131 127	0.618	165
* 250	63	193 131 137	0.627	165
** 280	63	193 131 147	0.359	165
** 315 - 355	63	193 131 157	0.373	165

53 131 400



Tapping Saddle Monobloc version

- PE 100 SDR 11 (ISO S5)
- 10 bar Gas / 16 bar Water
- With integrated cutter to tap live mains under pressure
- Complete with lower part
- 4 mm pin connectors
- Limited path fusion indicators
- Long fusion outlet
- O-ring-sealed screw cap

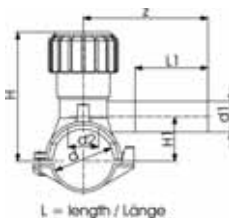

L = length / Länge

d [mm]	d1 [mm]	Code	kg	d2 [mm]	H [mm]	H1 [mm]	L [mm]	L1 [mm]	z [mm]
40	20	193 131 412	0.225	16	99	33	103	70	102
40	25	193 131 413	0.226	16	99	33	103	70	102
40	32	193 131 414	0.225	16	99	33	103	70	120
50	20	193 131 422	0.214	16	104	38	103	70	102
50	25	193 131 423	0.212	16	104	38	103	70	102
50	32	193 131 424	0.228	16	104	38	103	70	120
63	20	193 131 432	0.428	25	134	44	126	70	115
63	25	193 131 433	0.431	25	134	44	126	70	115
63	32	193 131 434	0.425	25	134	44	126	70	130

Tapping Saddle with 360° rotatable outlet

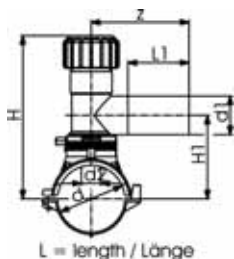

- PE 100 SDR 11 (ISO S5)
- 10 bar Gas / 16 bar Water
- With integrated cutter to tap live mains under pressure
- Complete with lower part
- 4 mm pin connectors
- Limited path fusion indicators
- Long fusion outlet
- O-ring-sealed screw cap
- d315-400mm: restricted application for pipes d355 and d400mm. Not suitable for pipes if wall thickness is larger than SDR17 pipes.
- *moulded-on lower clamp
- **Delivery without lower part for assembling as Top Load with tool no. 799.350.477; angle adaptor (799.350.340) for fusion cable required

d [mm]	d1 [mm]	Code	kg	d2 [mm]	H [mm]	H1 [mm]	L [mm]	L1 [mm]	z [mm]
63	20	193 131 402	0.697	32	186	108	165	71	130
63	25	193 131 403	0.637	32	186	108	165	71	130
63	32	193 131 404	0.701	32	186	108	165	76	130
63	40	193 131 405	0.718	32	186	108	165	81	137
63	63	193 131 437	1.426	32	134	112	165	100	160
75	20	193 131 442	0.831	32	191	113	165	71	130
75	25	193 131 443	0.830	32	191	113	165	71	130
75	32	193 131 444	0.812	32	191	113	165	76	130
75	40	193 131 445	0.849	32	191	113	165	81	137
75	63	193 131 447	1.565	32	240	118	165	100	160
90	20	193 131 452	0.793	32	199	121	165	71	130
90	25	193 131 453	0.790	32	199	121	165	71	130
90	32	193 131 454	0.770	32	199	121	165	76	130
90	40	193 131 455	0.811	32	199	121	165	81	137
90	63	193 131 457	1.494	32	248	126	165	100	160
* 110	20	193 131 462	0.826	32	209	131	165	71	130
* 110	25	193 131 463	0.808	32	209	131	165	71	130
* 110	32	193 131 464	0.831	32	209	131	165	76	130
* 110	40	193 131 465	0.805	32	209	131	165	81	137
* 110	63	193 131 467	1.097	35	258	136	165	100	160
125	20	193 131 472	0.880	32	216	138	165	71	130
125	25	193 131 473	0.878	32	216	138	165	71	130
125	32	193 131 474	0.878	32	216	138	165	76	130
125	40	193 131 475	0.874	32	216	138	165	81	137
125	63	193 131 477	1.184	35	265	143	165	100	160
140	20	193 131 482	0.887	32	233	146	165	71	130
140	25	193 131 483	0.874	32	233	146	165	71	130
140	32	193 131 484	0.894	32	233	146	165	76	130
140	40	193 131 485	0.920	32	233	146	165	81	137
140	63	193 131 487	1.180	35	273	151	165	100	160
* 160	20	193 131 492	0.916	32	243	156	165	71	130
* 160	25	193 131 493	0.912	32	243	156	165	71	130
* 160	32	193 131 494	0.915	32	243	156	165	76	130
* 160	40	193 131 495	0.936	32	243	156	165	81	137
* 160	63	193 131 497	1.221	35	283	161	165	100	160
180	20	193 131 502	0.994	32	244	166	165	71	130
180	25	193 131 503	1.001	32	244	166	165	71	130
180	32	193 131 504	0.957	32	244	166	165	76	130
180	40	193 131 505	1.007	32	244	166	165	81	137
180	63	193 131 507	1.587	35	293	171	165	100	160
200	20	193 131 512	1.015	32	254	176	165	71	137
200	25	193 131 513	1.015	32	254	176	165	71	130
200	32	193 131 514	0.985	32	254	176	165	76	130
200	40	193 131 515	1.024	32	254	176	165	81	137
200	63	193 131 517	1.745	35	303	181	165	100	160
225	20	193 131 522	1.016	32	266	188	165	71	130
225	25	193 131 523	1.025	32	266	188	165	71	130
225	32	193 131 524	1.019	32	266	188	165	76	130
225	40	193 131 525	1.029	32	266	188	165	81	137

table continued next page

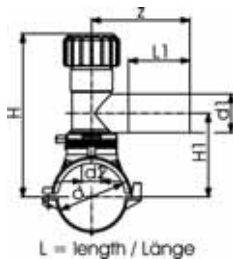

d [mm]	d1 [mm]	Code	kg	d2 [mm]	H [mm]	H1 [mm]	L [mm]	L1 [mm]	z [mm]
225	63	193 131 527	1.738	35	315	193	165	100	160
250	20	193 131 532	1.025	32	279	201	165	76	130
250	25	193 131 533	1.026	32	279	201	165	76	130
250	32	193 131 534	0.996	32	279	201	165	76	130
250	40	193 131 535	1.008	32	279	201	165	81	137
250	63	193 131 537	1.733	35	328	206	165	100	160
** 280	63	193 131 547	1.478	35	328	206	165	100	160
** 315-355	63	193 131 557	1.481	35	328	206	165	100	160

53 131 200

Spigot Saddle with Cutter

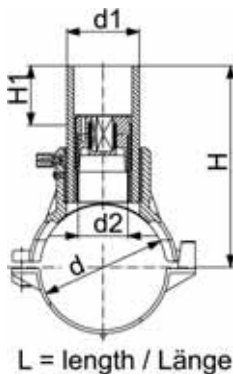

- PE 100 SDR 11 (ISO S5)
- 10 bar Gas / 16 bar Water
- Complete with lower part
- 4 mm pin connectors
- Limited path fusion indicators
- d315 - 400 mm: application is limited on pipes d355 and d400 mm. Not suitable for pipes if larger wall thickness than SDR 17 pipes.
- **Delivery without lower part for assembling as Top Load with tool no. 799.350.477; angle adaptor (799.350.340) for fusion cable required

d [mm]	d1 [mm]	Code	kg	d2 [mm]	H [mm]	H1 [mm]	L [mm]	SW [mm]
63	32	193 131 234	0.469	19	145	50	165	13
63	63	193 131 237	1.036	32	152	50	165	17
75	32	193 131 244	0.618	19	151	50	165	13
75	63	193 131 247	1.166	32	158	50	165	17
90	32	193 131 254	0.543	19	158	50	165	13
90	63	193 131 257	1.128	32	165	50	165	17
110	32	193 131 264	0.607	19	168	50	165	13
110	63	193 131 267	1.195	32	175	50	165	17
125	32	193 131 274	0.659	19	176	50	165	13
125	63	193 131 277	1.224	32	183	50	165	17
140	32	193 131 284	0.679	19	183	50	165	13
140	63	193 131 287	1.224	32	190	50	165	17
160	32	193 131 294	0.652	19	193	50	165	13
160	63	193 131 297	1.186	32	200	50	165	17
180	32	193 131 304	0.777	19	203	50	165	13
180	63	193 131 307	1.316	32	210	50	165	17
200	32	193 131 314	0.854	19	213	50	165	13
200	63	193 131 317	1.352	32	220	50	165	17
225	32	193 131 324	0.856	19	226	50	165	13
225	63	193 131 327	1.324	32	233	50	165	17
250	32	193 131 334	0.787	19	238	50	165	13
250	63	193 131 337	1.348	32	245	50	165	17
** 280	63	193 131 347	0.830	35	245	50	165	17
** 315 - 355	63	193 131 357	1.094	35	245	50	165	17

20 92 07

Transition coupler PE/brass (Ms 58) Male thread

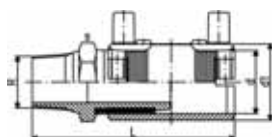

- PE 100 SDR 11 (ISO S5)
- 10 bar Gas / 16 bar Water
- With integral pipe fixation
- 4 mm pin connectors
- Limited path fusion indicators
- Supplied as a kit

d [mm]	R [inch]	Code	kg	d1 [mm]	L [mm]	s [mm]
20	½	720 920 756	0.187	31	110	30
20	1	720 920 754	0.344	44	124	40
25	¾	720 920 757	0.254	36	111	35
25	1	720 920 763	0.340	44	124	40
32	½	720 920 764	0.213	44	121	30
32	¾	720 920 765	0.268	44	122	35

table continued next page

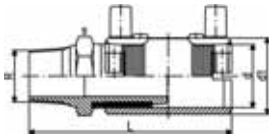

d [mm]	R [inch]	Code	kg	d1 [mm]	L [mm]	s [mm]
32	1	720 920 758	0.340	44	117	40
32	1 ¼	720 920 766	0.489	54	135	50
32	1 ½	720 920 767	0.635	60	143	60
32	2	720 920 768	1.000	81	157	70
40	1	720 920 771	0.364	54	133	40
40	1 ¼	720 920 759	0.514	54	127	50
40	1 ½	720 920 772	0.645	66	143	60
40	2	720 920 773	0.961	81	157	70
50	1	720 920 776	0.367	66	141	40
50	1 ¼	720 920 777	0.554	66	143	50
50	1 ½	720 920 760	0.652	66	135	60
50	2	720 920 778	0.971	81	157	70
63	1	720 920 781	0.441	81	151	40
63	1 ¼	720 920 782	0.600	81	153	40
63	1 ½	720 920 783	0.712	81	153	60
63	2	720 920 761	0.943	81	147	70

20 92 02



Transition coupler PE/brass (Ms 58) Female thread

- PE 100 SDR 11 (ISO S5)
- 10 bar Gas / 16 bar Water
- With integral pipe fixation
- 4 mm pin connectors
- Limited path fusion indicators
- Supplied as a kit

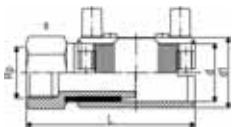

d [mm]	Rp [inch]	Code	kg	d1 [mm]	L [mm]	s [mm]
32	1	720 920 258	0.306	44	108	40
40	1 ¼	720 920 259	0.496	54	118	50
50	1 ½	720 920 260	0.725	66	126	60
63	1	720 920 281	1.300	81	138	70
63	1 ¼	720 920 282	1.230	81	138	70
63	1 ½	720 920 283	1.134	81	138	70
63	2	720 920 261	1.057	81	138	70

20 91 00



Transition Coupler PE/brass (Ms 58) with loose Nut

- PE 100 SDR 11 (ISO S5)
- 16 bar Water
- With integral pipe fixation
- 4 mm pin connectors
- Limited path fusion indicators
- Delivered as a kit. Further combinations: modular system with threaded adapter and reductions
- Incl. flat gasket for water applications (KTW / WRAS approved)

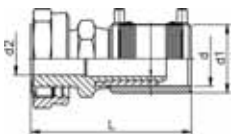

d [mm]	Rp [inch]	Code	kg	d1 [mm]	d2 [mm]	L [mm]
25	¾	720 910 007	0.232	36	15	104
25	1	720 910 017	0.315	36	16	106
32	1	720 910 008	0.297	44	20	110
32	1 ¼	720 910 018	0.460	44	22	114
32	1 ½	720 910 028	0.480	44	22	114
40	1	720 910 009	0.465	54	21	119
40	1 ¼	720 910 019	0.520	54	25	123
40	1 ½	720 910 029	0.577	54	28	123
50	1	720 910 020	0.635	66	20	128
50	1 ¼	720 910 030	0.730	66	25	133
50	1 ½	720 910 010	0.736	66	29	133
50	2	720 910 040	0.929	66	36	137
63	1	720 910 021	1.013	81	20	137

table continued next page

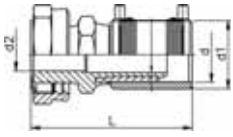

d [mm]	Rp [inch]	Code	kg	d1 [mm]	d2 [mm]	L [mm]
63	1 ¼	720 910 031	1.060	81	25	141
63	1 ½	720 910 041	1.070	81	29	141
63	2	720 910 011	1.251	81	36	145

20 10 07

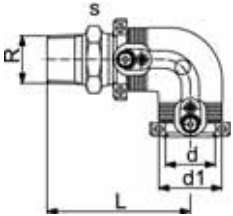

Transition elbow 90° PE/brass (Ms 58) Male thread

- PE 100 SDR 11 (ISO S5)
- 10 bar Gas / 16 bar Water
- With integral pipe fixation
- 4 mm pin connectors
- Limited path fusion indicators
- Supplied as a kit

d [mm]	R [inch]	Code	kg	d1 [mm]	L [mm]	s [mm]
20	½	720 100 756	0.240	31	96	30
25	¾	720 100 757	0.260	36	97	35
32	1	720 100 758	0.368	44	98	40
32	1 ¼	720 100 766	0.500	44	100	50
32	1 ½	720 100 767	0.562	44	100	60
40	1	720 100 771	0.511	54	107	50
40	1 ¼	720 100 759	0.534	54	109	50
40	1 ½	720 100 772	0.615	54	109	60
50	1	720 100 776	0.677	66	116	60
50	1 ¼	720 100 777	0.771	66	118	60
50	1 ½	720 100 760	0.734	66	118	60
63	1 ¼	720 100 782	1.040	81	128	70
63	1 ½	720 100 783	1.039	81	128	70
63	2	720 100 761	1.108	81	132	70

20 10 02

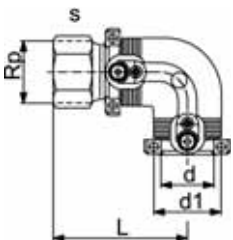

Transition elbow 90° PE/brass (Ms 58) Female thread

- PE 100 SDR 11 (ISO S5)
- 10 bar Gas / 16 bar Water
- With integral pipe fixation
- 4 mm pin connectors
- Limited path fusion indicators
- Supplied as a kit

d [mm]	Rp [inch]	Code	kg	d1 [mm]	L [mm]	s [mm]
32	1	720 100 258	0.359	44	89	40
40	1 ¼	720 100 259	0.525	54	100	50
50	1 ½	720 100 260	0.825	66	109	60
63	1	720 100 281	1.420	81	123	70
63	1 ¼	720 100 282	1.391	81	123	70
63	1 ½	720 100 283	1.305	81	123	70
63	2	720 100 261	1.165	81	123	70

20 10 00

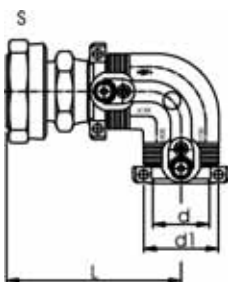

Transition Elbow 90° PE/brass (Ms 58) with loose Nut

- PE 100 SDR 11 (ISO S5)
- 16 bar Water
- With integral pipe fixation
- 4 mm pin connectors
- Limited path fusion indicators
- Supplied as a kit
- Incl. flat gasket for water applications (KTW / WRAS approved)

d [mm]	Rp [inch]	Code	kg	d1 [mm]	L [mm]
25	¾	720 100 007	0.240	36	90
25	1	720 100 017	0.310	36	92
32	1	720 100 008	0.347	44	91
32	1 ¼	720 100 018	0.490	44	95
40	1	720 100 009	0.505	54	101
40	1 ¼	720 100 019	0.565	54	105
40	1 ½	720 100 029	0.635	54	105
50	1	720 100 020	0.760	66	111
50	1 ½	720 100 010	0.850	66	116
50	2	720 100 040	1.060	66	120
63	1	720 100 021	1.114	81	121
63	1 ½	720 100 041	1.210	81	125
63	2	720 100 011	1.375	81	129

24 92 07

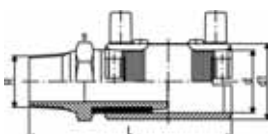

Transition coupler PE/steel (stainless 1.4305) Male thread

- PE 100 SDR 11 (ISO S5)
- 10 bar Gas / 16 bar Water
- With integral pipe fixation
- 4 mm pin connectors
- Limited path fusion indicators
- Delivered as a kit. Further combinations: modular system with threaded adapter and reductions

d [mm]	R [inch]	Code	kg	d1 [mm]	L [mm]	s [mm]
20	½	724 920 756	0.165	31	110	30
25	¾	724 920 757	0.249	36	111	35
32	1	724 920 758	0.332	44	117	40
40	1 ¼	724 920 759	0.464	54	127	50
40	1 ½	724 920 772	0.528	66	143	60
50	1 ½	724 920 760	0.611	66	135	60
63	1 ½	724 920 771	0.904	81	147	70
63	2	724 920 761	0.942	81	147	70

24 92 02

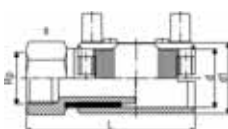

Transition coupler PE/steel (stainless 1.4305) Female thread

- PE 100 SDR 11 (ISO S5)
- 10 bar Gas / 16 bar Water
- With integral pipe fixation
- 4 mm pin connectors
- Limited path fusion indicators
- Supplied as a kit

d [mm]	Rp [inch]	Code	kg	d1 [mm]	L [mm]	s [mm]
20	½	724 920 256	0.179	31	100	30
25	¾	724 920 257	0.231	36	101	35
32	1	724 920 258	0.319	44	108	40
40	1 ¼	724 920 259	0.480	54	118	50
50	1 ½	724 920 260	0.646	66	126	60
63	2	724 920 261	0.931	81	138	70

24 10 07

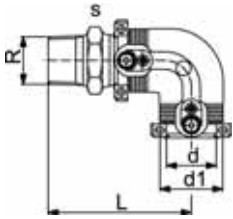

Transition elbow 90° PE/steel (stainless 1.4305) Male thread

- PE 100 SDR 11 (ISO S5)
- 10 bar Gas / 16 bar Water
- With integral pipe fixation
- 4 mm pin connectors
- Limited path fusion indicators
- Supplied as a kit

d [mm]	R [inch]	Code	kg	d1 [mm]	L [mm]	s [mm]	
20	½	724 100 756	0.211	31	96	30	
25	¾	724 100 757	0.230	36	97	35	
32	1	724 100 758	0.324	44	98	40	
40	1 ¼	724 100 759	0.560	54	109	50	
40	1 ½	724 100 772	0.599	54	109	60	
50	1 ½	724 100 760	0.701	66	118	60	
63	1 ½	724 100 771	0.986	81	132	70	
63	2	724 100 761	1.105	81	132	70	

24 10 02

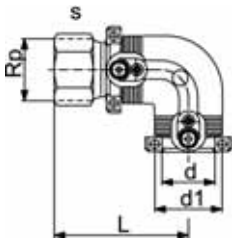

Transition elbow 90° PE/steel (stainless 1.4305) Female thread

- PE 100 SDR 11 (ISO S5)
- 10 bar Gas / 16 bar Water
- With integral pipe fixation
- 4 mm pin connectors
- Limited path fusion indicators
- Supplied as a kit

d [mm]	Rp [inch]	Code	kg	d1 [mm]	L [mm]	s [mm]	
20	½	724 100 256	0.211	31	86	30	
25	¾	724 100 257	0.237	36	87	35	
32	1	724 100 258	0.320	44	89	40	
40	1 ¼	724 100 259	0.545	54	100	50	
50	1 ½	724 100 260	0.805	66	109	60	
63	2	724 100 261	1.020	81	123	70	

Union adaptor

- With female thread and PE-union end
- The Code Nr. includes the entire union (galvanised)
- PE 100 SDR 11 (ISO S5)

d [mm]	Rp [inch]	Code	kg	L [mm]	L2 [mm]	SW1 [mm]	G [inch]	
20	½	701 485 560	0.152	94	52	27	1	
25	¾	701 485 561	0.252	100	52	32	1 1/4	
32	1	701 485 562	0.333	108	54	34	1 1/2	
40	1 ¼	701 485 563	0.563	114	57	43	2	
50	1 ½	701 485 564	0.765	124	65	50	2 1/4	
63	2	701 485 565	1.054	134	65	61	2 3/4	

24 92 07

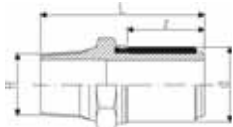

Transition adaptor PE/steel (stainless 1.4305) Male thread

- PE 100 SDR 11 (ISO S5)
- 10 bar Gas / 16 bar Water
- Only for ELGEF Plus Couplers and Fittings

d [mm]	R [inch]	Code	kg	L [mm]	z [mm]	
20	½	724 920 706	0.120	75	33	
25	¾	724 920 707	0.179	76	33	
32	1	724 920 708	0.244	80	35	
40	1 ¼	724 920 709	0.390	86	39	
40	1 ½	724 920 719	0.446	86	39	

table continued next page

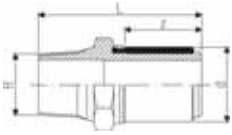

d [mm]	R [inch]	Code	kg	L [mm]	z [mm]
50	1 ½	724 920 710	0.478	90	43
63	1 ½	724 920 721	0.653	98	47
63	2	724 920 711	0.722	98	47

24 92 02

Transition adaptor PE/steel (stainless 1.4305) Female thread



- PE 100 SDR 11 (ISO S5)
- 10 bar Gas / 16 bar Water
- Only for ELGEF Plus Couplers and Fittings

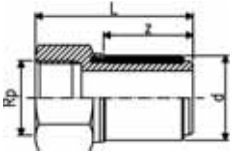

d [mm]	Rp [inch]	Code	kg	L [mm]	z [mm]
20	½	724 920 206	0.128	65	33
25	¾	724 920 207	0.181	66	33
32	1	724 920 208	0.237	71	35
40	1 ¼	724 920 209	0.373	77	39
50	1 ½	724 920 210	0.527	81	43
63	2	724 920 211	0.733	89	47

20 92 00

Transition adaptor PE/brass Loose nut (Ms 58)



- PE 100 SDR 11 (ISO S5)
- 16 bar Water
- Only for ELGEF Plus Couplers and Fittings
- Incl. flat gasket for water applications (KTW / WRAS approved)

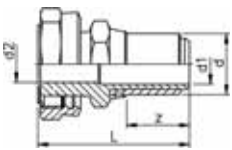

d [mm]	Rp [inch]	Code	kg	d2 [mm]	L [mm]	z [mm]
25	¾	720 920 007	0.152	15	68	32
25	1	720 920 017	0.223	16	70	32
32	1	720 920 008	0.235	20	72	34
32	1 ¼	720 920 018	0.356	22	76	34
32	1 ½	720 920 028	0.355	22	76	34
40	1	720 920 009	0.341	21	77	38
40	1 ¼	720 920 019	0.401	25	81	38
40	1 ½	720 920 029	0.471	28	81	38
50	1	720 920 020	0.517	20	82	42
50	1 ¼	720 920 030	0.549	25	87	42
50	1 ½	720 920 010	0.584	29	87	42
50	2	720 920 040	0.808	36	91	42
63	1	720 920 021	0.804	20	87	46
63	1 ¼	720 920 031	0.850	25	91	46
63	1 ½	720 920 041	0.847	29	91	46
63	2	720 920 011	1.018	36	95	46

20 92 02

Transition adaptor PE/brass (Ms 58) Female thread



- PE 100 SDR 11 (ISO S5)
- 10 bar Gas / 16 bar Water
- Only for ELGEF Plus Couplers and Fittings

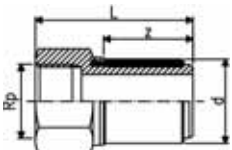

d [mm]	Rp [inch]	Code	kg	L [mm]	z [mm]
32	1	720 920 208	0.250	71	35
40	1 ¼	720 920 209	0.386	77	39
50	1 ½	720 920 210	0.594	81	43
63	1	720 920 221	1.100	89	47
63	1 ¼	720 920 231	1.062	89	47
63	1 ½	720 920 241	0.958	89	47
63	2	720 920 211	0.832	89	47

20 92 07

Transition adaptor PE/brass (Ms 58) Male thread

- PE 100 SDR 11 (ISO S5)
- 10 bar Gas / 16 bar Water
- Only for ELGEF Plus Couplers and Fittings



d [mm]	R [inch]	Code	kg	L [mm]	z [mm]
20	½	720 920 706	0.133	75	33
25	¾	720 920 707	0.182	76	33
32	1	720 920 708	0.257	80	35
32	1 ¼	720 920 718	0.370	82	35
32	1 ½	720 920 728	0.437	82	35
40	1	720 920 719	0.358	84	39
40	1 ¼	720 920 709	0.410	86	39
40	1 ½	720 920 729	0.454	86	39
50	1	720 920 720	0.505	88	43
50	1 ¼	720 920 730	0.539	90	43
50	1 ½	720 920 710	0.514	90	43
63	1 ¼	720 920 721	0.739	94	47
63	1 ½	720 920 731	0.709	94	47
63	2	720 920 711	0.762	98	47

Spigot Fittings for Electrofusion

53 10 10

Elbow 90° PE100 SDR11

- Long spigot version
- 10 bar Gas / 16 bar Water



d [mm]	Code	kg	z [mm]	L [mm]	e [mm]	PF
20	753 101 006	0.027	75	52	3.0	2 51 301 001
25	753 101 007	0.040	80	52	3.0	2 51 301 001
32	753 101 008	0.056	85	54	3.0	2 51 301 001
40	753 101 009	0.089	95	57	3.7	2 51 301 001
50	753 101 010	0.156	105	63	4.6	2 51 301 001
63	753 101 011	0.274	115	65	5.8	2 51 301 001
75	753 101 012	0.414	130	72	6.8	2 51 301 001
90	753 101 013	0.704	150	81	8.2	2 51 301 001
110	753 101 014	1.158	165	86	10.0	2 51 301 001
125	753 101 015	1.609	180	93	11.4	2 51 301 001
140	753 101 016	2.222	194	92	12.7	2 51 301 001
160	753 101 017	3.100	210	103	14.6	2 51 301 001
180	753 101 018	4.328	232	107	16.4	2 51 301 001
200	753 101 019	5.739	253	117	18.2	2 51 301 001
225	753 101 020	7.775	270	122	20.5	2 51 301 001
250	753 101 001	10.506	292	130	22.7	2 51 301 002
280	753 100 922	15.059	320	140	25.4	2 51 301 002
315	753 100 923	21.960	370	150	28.6	2 51 301 002

53 10 08

Elbow 90° PE100 SDR17/17,6

- Long spigot version
- 5 bar Gas / 10 bar Water



d [mm]	Code	kg	z [mm]	L [mm]	e [mm]	PF
90	753 100 813	0.543	150	81	5,4	2 51 301 001
110	753 100 814	0.876	165	86	6,6	2 51 301 001
125	753 100 815	0.927	180	93	7,4	2 51 301 001
140	753 100 816	1.547	194	92	8,3	2 51 301 001
160	753 100 817	2.385	210	102	9,5	2 51 301 001
180	753 100 818	3.205	232	107	10,7	2 51 301 001
200	753 100 819	4.298	253	115	11,9	2 51 301 001
225	753 100 820	5.864	270	120	13,4	2 51 301 001
250	753 100 821	8.000	292	130	14,8	2 51 301 002
280	753 100 822	11.328	320	140	16,6	2 51 301 002
315	753 100 823	15.877	370	150	18,7	2 51 301 002

53 00 09

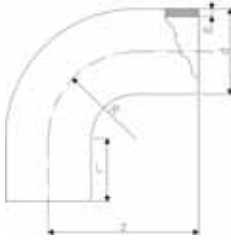
Bend 90° PE100 SDR11

- Long spigot version
 - 10 bar Gas / 16 bar Water
 - bends made out of seamless pipe shall not be shortened
- * made out of seamless pipe

d [mm]	Code	kg	z [mm]	L [mm]	R [mm]	e [mm]
32	753 001 008	0.050	78	46	32	2,9
40	753 001 009	0.090	91	49	40	3,7
50	753 001 010	0.160	107	55	50	4,6
63	753 001 011	0.280	130	63	63	5,8
75	753 001 012	0.464	152	70	75	6,8
90	753 001 013	0.530	168	79	90	8,2
110	753 001 014	1.282	193	82	110	10,0
125	753 001 015	1.290	216	87	125	11,4
140	753 001 016	2.230	232	92	140	12,7
160	753 001 017	3.424	258	98	160	14,6
180	753 001 018	5.000	290	105	180	16,4
200	753 001 019	6.925	317	112	200	18,2
225	753 001 020	9.770	350	120	225	20,5
250	753 001 021	9.230	375	130	250	22,7
280	753 001 022	15.487	430	150	280	25,4
315	753 001 023	23.950	470	150	315	28,6
* 355	753 001 024	53.300	900	250	533	32,3
* 400	753 001 025	71.900	980	250	600	36,4
* 450	753 001 026	97.300	1070	250	675	40,9
* 500	753 001 027	134.000	1200	280	750	45,5
* 560	753 001 028	179.300	1290	280	840	50,9
* 630	753 001 029	243.200	1400	280	945	57,3
* 710	753 001 030	469.943	2200	570	1630	64,5
* 800	753 001 031	577.131	2200	480	1720	72,6

53 00 08

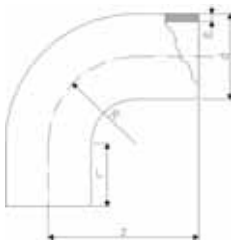
Bend 90° PE100 SDR17

- Long spigot version
 - 5 bar Gas / 10 bar Water
 - bends made out of seamless pipe shall not be shortened
- * made out of seamless pipe

d [mm]	Code	kg	z [mm]	L [mm]	R [mm]	e [mm]
90	753 000 813	0.521	168	79	90	5,4
110	753 000 814	0.465	193	82	110	6,6
125	753 000 815	1.300	216	87	125	7,4
140	753 000 816	1.789	232	92	140	8,3
160	753 000 817	2.410	258	98	160	9,5
180	753 000 818	4.000	290	105	180	10,7
200	753 000 819	6.500	317	112	200	11,9
225	753 000 820	6.414	350	120	225	13,4
250	753 000 821	9.940	375	130	250	14,8
280	753 000 822	13.795	430	150	280	16,6
315	753 000 823	24.000	470	150	315	18,7
* 355	753 000 824	36.700	900	250	533	21,1
* 400	753 000 825	49.700	980	250	600	23,7
* 450	753 000 826	66.600	1070	250	675	26,7
* 500	753 000 827	87.400	1200	280	750	29,7
* 560	753 000 828	116.000	1290	280	840	33,2
* 630	753 000 829	159.600	1400	280	945	37,4
* 710	753 000 830	317.382	2200	570	1630	42,1
* 800	753 000 831	389.859	2200	480	1720	47,4

53 00 08

Bend 90° PE100 SDR17**Model:**

- Long spigot
- Conventional butt-welding according to DVS 2207 part 1
- Production process: segment welded
- Segment-welded fittings have a pressure reduction factor of 0.8
- 8 bar water

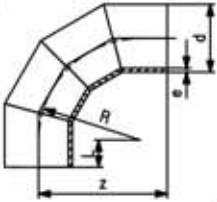

d [mm]	Code	kg	z [mm]	L [mm]	R [mm]	e [mm]
710	753 002 001	202.419	1415	350	1065	42.1
800	753 002 002	279.918	1550	350	1200	47.4
900	753 002 003	386.595	1700	350	1350	53.3
1000	753 002 004	534.660	1900	400	1500	59.3

53 07 10

Bend 60° PE100 SDR11

- Long spigot version
- 10 bar Gas / 16 bar Water
- made out of seamless pipe
- bends made out of seamless pipe shall not be shortened

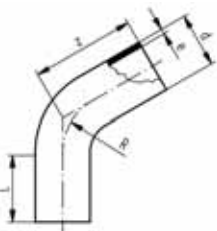

d [mm]	Code	kg	z [mm]	L [mm]	R [mm]	e [mm]
32	753 071 008	0.070	128	80	48	2,9
40	753 071 009	0.120	135	80	60	3,7
50	753 071 010	0.240	158	100	75	4,6
63	753 071 011	0.420	173	100	95	5,8
75	753 071 012	0.600	182	100	113	6,8
90	753 071 013	0.900	193	100	135	8,2
110	753 071 014	1.780	270	150	165	10,0
125	753 071 015	2.500	283	150	188	11,4
140	753 071 016	2.700	296	150	210	12,7
160	753 071 017	4.574	313	150	240	14,6
180	753 071 018	4.900	330	150	270	16,4
200	753 071 019	6.400	348	150	300	18,2
225	753 071 020	8.600	370	150	338	20,5
250	753 071 021	14.500	500	250	375	22,7
280	753 071 022	19.100	530	250	420	25,4
315	753 071 023	25.600	612	250	473	28,6
355	753 071 024	41.700	690	300	533	32,3
400	753 071 025	55.800	730	300	600	36,4
450	753 071 026	76.000	780	300	675	40,9
500	753 071 027	104.600	880	350	750	45,5
560	753 071 028	139.500	930	350	840	50,9
630	753 071 029	188.500	1000	350	945	57,3

53 07 08

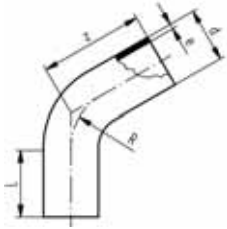
Bend 60° PE100 SDR17/17,6

- Long spigot version
- 5 bar Gas / 10 bar Water
- made out of seamless pipe
- bends made out of seamless pipe shall not be shortened

d [mm]	Code	kg	z [mm]	L [mm]	R [mm]	e [mm]	
90	753 070 813	0.600	193	100	135	5,4	
110	753 070 814	1.280	270	150	165	6,6	
125	753 070 815	1.300	283	150	187	7,4	
140	753 070 816	1.800	296	150	210	8,3	
160	753 070 817	3.160	313	150	240	9,5	
180	753 070 818	3.190	330	150	270	10,7	
200	753 070 819	4.200	348	150	300	11,9	
225	753 070 820	5.600	370	150	337	13,4	
250	753 070 821	9.250	500	250	375	14,8	
280	753 070 822	15.000	530	250	420	16,6	
315	753 070 823	19.500	612	250	472	18,7	
355	753 070 824	30.100	690	300	532	21,1	
400	753 070 825	38.200	730	300	600	23,7	
450	753 070 826	53.700	780	300	675	26,7	
500	753 070 827	73.900	880	350	750	29,7	
560	753 070 828	98.200	930	350	840	33,2	
630	753 070 829	132.300	1000	350	945	37,4	

53 15 10

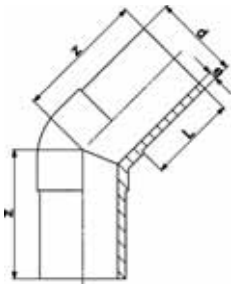
Elbow 45° PE100 SDR11

- Long spigot version
- 10 bar Gas / 16 bar Water

d [mm]	Code	kg	z [mm]	L [mm]	e [mm]	PF	
20	753 151 006	0.027	70	52	3,0	2 51 301 001	
25	753 151 007	0.037	75	52	3,0	2 51 301 001	
32	753 151 008	0.050	80	54	3,0	2 51 301 001	
40	753 151 009	0.086	85	57	3,7	2 51 301 001	
50	753 151 010	0.133	90	63	4,6	2 51 301 001	
63	753 151 011	0.227	95	65	5,8	2 51 301 001	
75	753 151 012	0.350	105	72	6,8	2 51 301 001	
90	753 151 013	0.565	120	81	8,2	2 51 301 001	
110	753 151 014	0.921	130	86	10,0	2 51 301 001	
125	753 151 015	1.290	140	92	11,4	2 51 301 001	
140	753 151 016	1.796	164	120	12,7	2 51 301 001	
160	753 151 017	2.454	162	102	14,6	2 51 301 001	
180	753 151 018	3.274	170	107	16,4	2 51 301 001	
200	753 151 019	4.362	186	116	18,2	2 51 301 001	
225	753 151 020	5.981	200	123	20,5	2 51 301 001	
250	753 151 021	8.283	220	130	22,7	2 51 301 002	
280	753 150 922	10.285	230	140	25,4	2 51 301 002	
315	753 150 923	14.124	250	150	28,6	2 51 301 002	

53 15 08

Elbow 45° PE100 SDR17/17,6

- Long spigot version
- 5 bar Gas / 10 bar Water

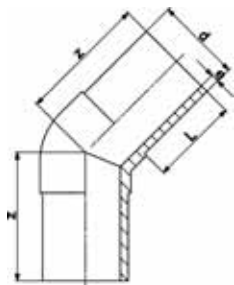

d [mm]	Code	kg	z [mm]	L [mm]	e [mm]	PF
90	753 150 813	0.411	120	81	5,4	2 51 301 001
110	753 150 814	0.686	130	86	6,6	2 51 301 001
125	753 150 815	0.948	140	92	7,4	2 51 301 001
140	753 150 816	1.259	164	120	8,3	2 51 301 001
160	753 150 817	1.901	162	102	9,5	2 51 301 001
180	753 150 818	2.386	170	107	10,7	2 51 301 001
200	753 150 819	3.153	186	116	11,9	2 51 301 001
225	753 150 820	4.441	205	123	13,4	2 51 301 001
250	753 150 821	6.012	217	130	14,8	2 51 301 002
280	753 150 822	7.489	230	140	16,6	2 51 301 002
315	753 150 823	10.123	250	150	18,7	2 51 301 002

53 05 10

Bend 45° PE100 SDR11

- Long spigot version
- 10 bar Gas / 16 bar Water
- made out of seamless pipe
- bends made out of seamless pipe shall not be shortened

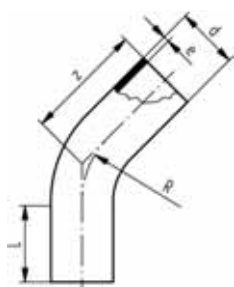

d [mm]	Code	kg	z [mm]	L [mm]	R [mm]	e [mm]
32	753 051 008	0.077	120	80	48	2,9
40	753 051 009	0.120	120	80	60	3,7
50	753 051 010	0.240	149	100	75	4,6
63	753 051 011	0.360	161	100	95	5,8
75	753 051 012	0.560	168	100	113	6,8
90	753 051 013	0.760	177	100	135	8,2
110	753 051 014	1.700	243	150	165	10,0
125	753 051 015	2.186	253	150	188	11,4
140	753 051 016	2.800	262	150	210	12,7
160	753 051 017	3.800	274	160	240	14,6
180	753 051 018	5.140	287	150	270	16,4
200	753 051 019	7.058	299	150	300	18,2
225	753 051 020	7.400	315	150	338	20,5
250	753 051 021	13.000	440	250	375	22,7
280	753 051 022	22.000	460	250	420	25,4
315	753 051 023	24.930	535	250	473	28,6
355	753 051 024	39.500	620	300	533	32,3
400	753 051 025	48.500	650	300	600	36,4
450	753 051 026	69.800	680	300	675	40,9
500	753 051 027	96.300	760	350	750	45,5
560	753 051 028	129.800	800	350	840	50,9
630	753 051 029	174.000	870	350	945	57,3

53 05 08

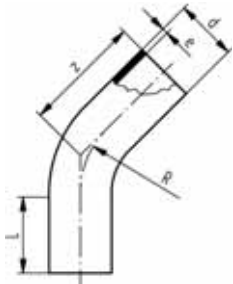
Bend 45° PE100 SDR17/17,6

- Long spigot version
- 5 bar Gas / 10 bar Water
- made out of seamless pipe
- bends made out of seamless pipe shall not be shortened

d [mm]	Code	kg	z [mm]	L [mm]	R [mm]	e [mm]
90	753 050 813	0.600	177	100	135	5,4
110	753 050 814	1.208	243	150	165	6,6
125	753 050 815	1.540	253	150	188	7,4
140	753 050 816	1.720	262	150	210	8,3
160	753 050 817	2.200	274	150	240	9,5
180	753 050 818	3.000	287	150	270	10,7
200	753 050 819	3.700	299	150	300	11,9
225	753 050 820	5.000	315	150	338	13,4
250	753 050 821	10.691	440	250	375	14,8
280	753 050 822	15.000	460	250	420	16,6
315	753 050 823	17.800	535	250	473	18,7
355	753 050 824	25.600	620	300	533	21,1
400	753 050 825	36.600	650	300	600	23,7
450	753 050 826	45.300	680	300	675	26,7
500	753 050 827	62.400	760	350	750	29,7
560	753 050 828	81.900	800	350	840	33,2
630	753 050 829	62.400	870	350	945	37,4

53 05 08

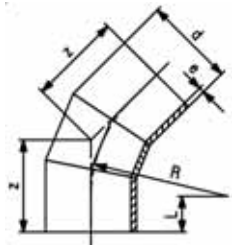
Bend 45° PE100 SDR17/17,6**Model:**

- Long spigot
- Conventional butt-welding according to DVS 2207 part 1
- Production process: segment welded
- Segment-welded fittings have a pressure reduction factor of 0.8
- 8 bar water

d [mm]	Code	kg	z [mm]	L [mm]	R [mm]	e [mm]
710	753 003 001	129.998	792	350	1065	42.1
800	753 003 002	176.165	847	350	1200	47.4
900	753 003 003	252.638	960	350	1350	53.3
1000	753 003 004	332.107	1022	400	1500	59.3

53 12 09

Elbow 30° PE100 SDR11

- Long spigot version
- 10 bar Gas / 16 bar Water
- Welded design



d [mm]	Code	kg	z [mm]	L [mm]	e [mm]
32	753 120 908	0.530	70	54	3,0
40	753 120 909	0.530	80	57	3,7
50	753 120 910	0.121	80	63	4,6
63	753 120 911	0.207	80	65	5,8
75	753 120 912	0.311	90	72	6,8
90	753 120 913	0.540	100	81	8,2
110	753 120 914	0.840	105	86	10,0
125	753 120 915	1.174	115	92	11,4
140	753 120 916	1.760	135	92	12,7
160	753 120 917	2.155	130	102	14,6
180	753 120 918	2.911	140	107	16,4
200	753 120 919	3.892	150	116	18,2
225	753 120 920	5.332	165	123	20,5
250	753 120 921	7.307	190	130	22,7
280	753 120 922	10.600	200	139	25,4
315	753 120 923	12.775	200	150	28,6

53 12 08

Elbow 30° PE100 SDR17

- Long spigot version
- 5 bar Gas / 10 bar Water
- Welded design



d [mm]	Code	kg	z [mm]	L [mm]	e [mm]
90	753 120 813	0.363	110	81	5,4
110	753 120 814	0.607	115	86	6,6
125	753 120 815	0.819	125	92	7,4
140	753 120 816	1.112	150	92	8,3
160	753 120 817	1.526	140	102	9,5
180	753 120 818	2.040	150	107	10,7
200	753 120 819	2.780	160	116	11,9
225	753 120 820	3.798	180	123	13,4
250	753 120 821	5.830	200	130	14,8
280	753 120 822	8.100	200	139	16,6
315	753 120 823	8.655	220	150	18,7

53 06 10

Bend 30° PE100 SDR11

- Long spigot version
- 10 bar Gas / 16 bar Water
- made out of seamless pipe
- bends made out of seamless pipe shall not be shortened

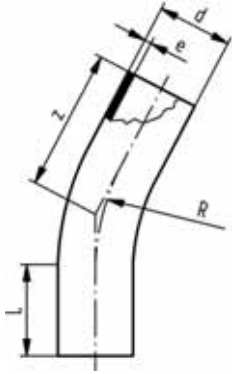

d [mm]	Code	kg	z [mm]	L [mm]	R [mm]	e [mm]
32	753 061 008	0.077	113	80	48	2,9
40	753 061 009	0.120	116	80	60	3,7
50	753 061 010	0.200	140	100	75	4,6
63	753 061 011	0.400	150	100	95	5,8
75	753 061 012	0.520	155	100	113	6,8
90	753 061 013	0.760	160	100	135	8,2
110	753 061 014	1.689	219	150	165	10,0
125	753 061 015	2.065	225	150	188	11,4
140	753 061 016	2.200	231	150	210	12,7
160	753 061 017	3.650	239	150	240	14,6
180	753 061 018	4.782	247	150	270	16,4
200	753 061 019	5.777	255	150	300	18,2
225	753 061 020	6.300	266	150	338	20,5
250	753 061 021	13.100	385	250	375	22,7
280	753 061 022	16.300	400	250	420	25,4
315	753 061 023	21.850	460	250	473	28,6
355	753 061 024	34.900	540	300	533	32,3
400	753 061 025	45.900	560	300	600	36,4
450	753 061 026	60.200	580	300	675	40,9
500	753 061 027	83.300	630	350	750	45,5
560	753 061 028	108.600	680	350	840	50,9
630	753 061 029	148.300	730	350	945	57,3

53 06 08

Bend 30° PE100 SDR17

- Long spigot version
- 5 bar Gas / 10 bar Water
- made out of seamless pipe
- bends made out of seamless pipe shall not be shortened

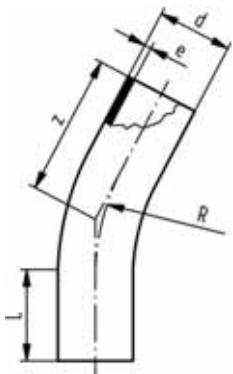

d [mm]	Code	kg	z [mm]	L [mm]	R [mm]	e [mm]
90	753 060 813	0.500	160	100	135	5,4
110	753 060 814	1.060	219	150	165	6,6
125	753 060 815	1.100	225	150	188	7,4
140	753 060 816	1.720	231	150	210	8,3
160	753 060 817	2.565	239	150	240	9,5
180	753 060 818	3.389	247	150	270	10,7
200	753 060 819	4.213	255	150	300	11,9
225	753 060 820	7.540	266	150	338	13,4
250	753 060 821	11.600	385	250	375	14,8
280	753 060 822	12.800	400	250	420	16,6
315	753 060 823	25.000	460	250	473	18,7
355	753 060 824	22.700	540	300	533	21,1
400	753 060 825	29.800	560	300	600	23,7
450	753 060 826	39.100	580	300	675	26,7
500	753 060 827	54.000	650	350	750	29,7
560	753 060 828	70.300	680	350	840	33,2
630	753 060 829	95.800	730	350	945	37,4

Bend 22° PE100 SDR11

- Long spigot version
- 10 bar Gas / 16 bar Water
- made out of seamless pipe
- bends made out of seamless pipe shall not be shortened

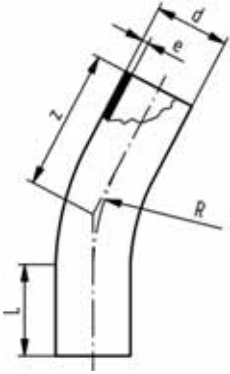

d [mm]	Code	kg	z [mm]	L [mm]	R [mm]	e [mm]
32	753 081 008	0.077	113	80	48	2,9
40	753 081 009	0.120	116	80	60	3,7
50	753 081 010	0.200	140	100	75	4,6
63	753 081 011	0.400	150	100	95	5,8
75	753 081 012	0.520	155	100	113	6,8
90	753 081 013	0.760	160	100	135	8,2
110	753 081 014	1.500	219	150	165	10,0
125	753 081 015	2.000	225	150	188	11,4
140	753 081 016	2.200	231	150	210	12,7
160	753 081 017	3.300	239	150	240	14,6
180	753 081 018	3.700	247	150	270	16,4
200	753 081 019	4.750	255	150	300	18,2
225	753 081 020	6.300	266	150	338	20,5
250	753 081 021	14.015	385	250	375	22,7
280	753 081 022	18.510	400	250	420	25,4
315	753 081 023	21.845	460	250	473	28,6
355	753 081 024	34.900	540	300	533	32,3
400	753 081 025	45.900	560	300	600	36,4
450	753 081 026	60.200	580	300	675	40,9
500	753 081 027	83.300	650	350	750	45,5
560	753 081 028	108.600	680	350	840	50,9
630	753 081 029	148.300	730	350	945	57,3

Bend 22° PE100 SDR17/17,6

- Long spigot version
- 5 bar Gas / 10 bar Water
- made out of seamless pipe
- bends made out of seamless pipe shall not be shortened

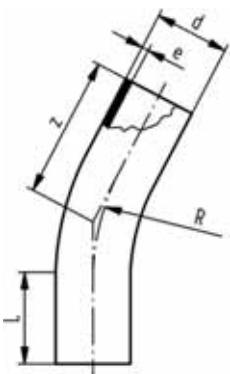

d [mm]	Code	kg	z [mm]	L [mm]	R [mm]	e [mm]
90	753 080 813	0.500	160	100	135	5.4
110	753 080 814	1.060	219	150	165	6.6
125	753 080 815	1.100	225	150	188	7.4
140	753 080 816	1.720	231	150	210	8.3
160	753 080 817	1.900	239	150	240	9.5
180	753 080 818	3.318	247	150	270	10.7
200	753 080 819	3.200	255	150	300	11.9
225	753 080 820	5.431	266	150	338	13.4
250	753 080 821	9.904	385	250	375	14.8
280	753 080 822	12.800	400	250	420	16.6
315	753 080 823	14.144	460	250	473	18.7
355	753 080 824	22.700	540	300	533	21.1
400	753 080 825	29.800	560	300	600	23.7
450	753 080 826	39.100	580	300	675	26.7
500	753 080 827	54.000	650	350	750	29.7
560	753 080 828	70.300	680	350	840	33.2
630	753 080 829	95.800	730	350	945	37.4

Elbow 15° type L PE100 SDR11

- Long spigot version
- 10 bar Gas / 16 bar Water
- Welded design

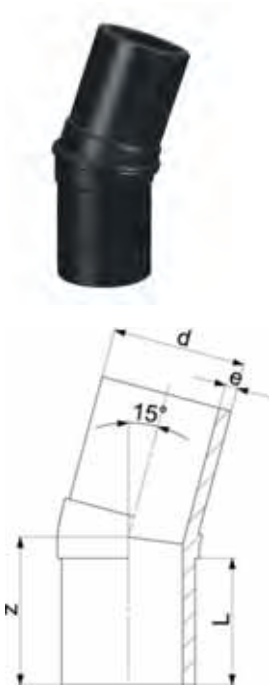

d [mm]	Code	kg	z [mm]	L [mm]	e [mm]
32	753 141 008	0.051	70	54	3.0
40	753 141 009	0.082	80	57	3.7
50	753 141 010	0.118	80	63	4.6
63	753 141 011	0.200	80	65	5.8
75	753 141 012	0.290	90	72	6.8
90	753 141 013	0.479	100	81	8.2
110	753 141 014	0.785	105	86	10.0
125	753 141 015	1.063	115	92	11.4
140	753 141 016	1.600	135	92	12.7
160	753 141 017	2.170	130	102	14.6
180	753 141 018	2.653	140	107	16.4
200	753 141 019	3.438	150	116	18.2
225	753 141 020	4.765	165	123	20.5
250	753 141 021	8.300	190	130	22.7
280	753 141 022	10.600	200	139	25.4
315	753 141 023	13.100	200	150	28.6

Elbow 15° PE100 SDR17/17,6

- Long spigot version
- 5 bar Gas / 10 bar Water
- Welded design



d [mm]	Code	kg	z [mm]	L [mm]	e [mm]
90	753 140 813	0.337	100	81	5.4
110	753 140 814	0.551	105	86	6.6
125	753 140 815	0.728	115	92	7.4
140	753 140 816	0.370	135	92	8.3
160	753 140 817	1.364	130	102	9.5
180	753 140 818	2.040	140	107	10.7
200	753 140 819	2.371	150	116	11.9
225	753 140 820	3.335	165	123	13.4
250	753 140 821	5.830	190	130	14.8
280	753 140 822	8.100	195	139	16.6
315	753 140 823	7.528	200	150	18.7

Bend 11° PE100 SDR11



- Long spigot version
- 10 bar Gas / 16 bar Water
- made out of seamless pipe
- bends made out of seamless pipe shall not be shortened

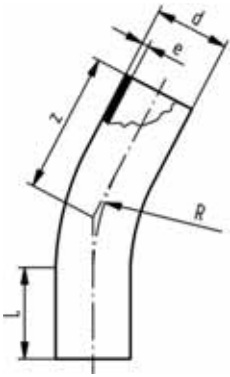

d [mm]	Code	kg	z [mm]	L [mm]	R [mm]	e [mm]
32	753 091 008	0.077	113	80	48	2.9
40	753 091 009	0.120	116	80	60	3.7
50	753 091 010	0.200	140	100	75	4.6
63	753 091 011	0.400	150	100	95	5.8
75	753 091 012	0.520	155	100	113	6.8
90	753 091 013	0.760	160	100	135	8.2
110	753 091 014	1.500	219	150	165	10.0
125	753 091 015	2.000	225	150	188	11.4
140	753 091 016	2.200	231	150	210	12.7
160	753 091 017	3.300	239	150	240	14.6
180	753 091 018	3.700	247	150	270	16.4
200	753 091 019	4.750	255	150	300	18.2
225	753 091 020	7.773	266	150	338	20.5
250	753 091 021	13.100	385	250	375	22.7
280	753 091 022	16.300	400	250	420	25.4
315	753 091 023	21.845	460	250	473	28.6
355	753 091 024	34.900	540	300	533	32.3
400	753 091 025	45.900	560	300	600	36.4
450	753 091 026	60.200	580	300	675	40.9
500	753 091 027	83.300	650	350	750	45.5
560	753 091 028	108.600	680	350	840	50.9
630	753 091 029	148.300	730	350	945	57.3

Bend 11° PE100 SDR17/17,6



- Long spigot version
- 5 bar Gas / 10 bar Water
- made out of seamless pipe
- bends made out of seamless pipe shall not be shortened

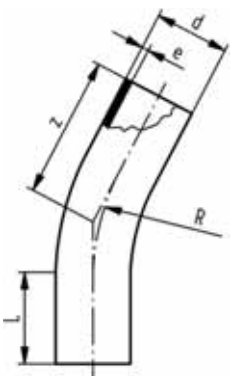

d [mm]	Code	kg	z [mm]	L [mm]	R [mm]	e [mm]
90	753 090 813	0.500	160	100	135	5.4
110	753 090 814	1.060	219	150	165	6.6
125	753 090 815	1.100	225	150	188	7.4
140	753 090 816	1.720	231	150	210	8.3
160	753 090 817	2.653	239	150	240	9.5
180	753 090 818	2.500	247	150	270	10.7
200	753 090 819	4.308	255	150	300	11.9
225	753 090 820	7.540	266	150	338	13.4
250	753 090 821	11.600	385	250	375	14.8
280	753 090 822	12.800	400	250	420	16.6
315	753 090 823	25.000	460	250	473	18.7
355	753 090 824	22.700	540	300	533	21.1
400	753 090 825	29.800	560	300	600	23.7
450	753 090 826	39.100	580	300	675	26.7
500	753 090 827	54.000	650	350	750	29.7
560	753 090 828	70.300	680	350	840	33.2
630	753 090 829	95.800	730	350	945	37.4



Bend 90° PE100 S5/SDR11

- For IR, butt- and electro fusion
- Reduction factor = 0,8

d [mm]	Code	L [mm]	L1 [mm]	e [mm]
110	700 648 928	315	150	10,0
125	700 648 929	338	150	11,4
140	700 648 930	360	150	12,8
160	700 648 931	390	150	14,6
180	700 648 932	420	150	16,4
200	700 648 933	450	150	18,2
225	700 648 934	488	150	20,5
250	700 648 935	625	250	22,8
280	700 648 936	670	250	25,5
315	700 648 937	773	300	28,7
355	700 648 938	833	300	32,3
400	700 648 939	900	300	36,4
450	700 648 940	975	300	41,0
500	700 648 941	1100	350	45,5
560	700 648 942	1190	350	51,0
630	700 648 943	1295	350	57,3



Bend 90° PE100 S8/SDR17.6

- For IR, butt- and electro fusion
- Reduction factor = 0,8

d [mm]	Code	kg	L [mm]	L1 [mm]	e [mm]
110	700 648 944	1.122	315	150	6,3
125	700 648 945	1.584	338	150	7,1
140	700 648 946	2.145	360	150	8,0
160	700 648 947	2.970	390	150	9,1
180	700 648 948	4.026	420	150	10,2
200	700 648 949	5.346	450	150	11,4
225	700 648 950	7.260	488	150	12,8
250	700 648 951	11.550	625	250	14,2
280	700 648 952	15.510	670	250	15,9
315	700 648 953	23.100	773	300	17,9
355	700 648 954	31.152	833	300	20,1
400	700 648 955	42.768	900	300	22,7
450	700 648 956	58.410	975	300	25,5
500	700 648 957	63.888	1100	350	28,3
560	700 648 958	85.140	1190	350	31,7
630	700 648 959	114.840	1295	350	35,7

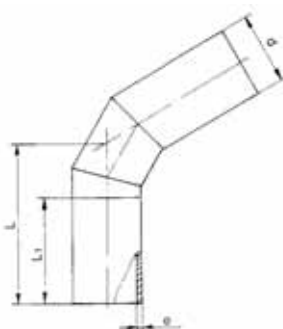

Bend 60° PE100 S5/SDR11

- For IR, butt- and electro fusion
- Reduction factor = 0,8

d [mm]	Code	kg	L [mm]	L1 [mm]	e [mm]
110	700 648 960	1.377	245	150	10,0
125	700 648 961	1.944	258	150	11,4
140	700 648 962	2.633	271	150	12,8
160	700 648 963	3.645	288	150	14,6
180	700 648 964	4.941	305	150	16,4
200	700 648 965	6.561	323	150	18,2
225	700 648 966	8.910	345	150	20,5
250	700 648 967	14.175	466	250	22,8
280	700 648 968	19.035	492	250	25,5
315	700 648 969	28.350	576	300	28,7
355	700 648 970	38.232	608	300	32,3
400	700 648 971	52.488	646	300	36,4
450	700 648 972	71.685	689	300	41,0

table continued next page

d [mm]	Code	kg	L [mm]	L1 [mm]	e [mm]
500	700 648 973	78.408	783	350	45,5
560	700 648 974	104.490	835	350	51,0
630	700 648 975	140.940	896	350	57,3

Bend 60° PE100 S8/SDR17.6

- For IR, butt- and electro fusion
- Reduction factor = 0,8

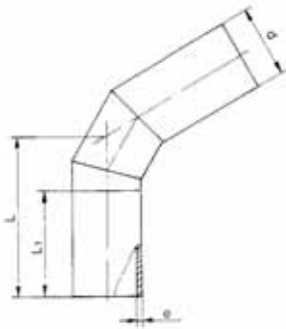

d [mm]	Code	kg	L [mm]	L1 [mm]	e [mm]
110	700 648 976	0.909	245	150	6,3
125	700 648 977	1.283	258	150	7,1
140	700 648 978	1.737	271	150	8,0
160	700 648 979	2.406	288	150	9,1
180	700 648 980	3.261	305	150	10,2
200	700 648 981	4.330	323	150	11,4
225	700 648 982	5.881	345	150	12,8
250	700 648 983	9.356	466	250	14,2
280	700 648 984	12.563	492	250	15,9
315	700 648 985	18.711	576	300	17,9
355	700 648 986	25.233	608	300	20,1
400	700 648 987	34.642	646	300	22,7
450	700 648 988	47.312	689	300	25,5
500	700 648 989	51.749	783	350	28,3
560	700 648 990	68.963	835	350	31,7
630	700 648 991	93.020	896	350	35,7

Bend 45° PE100 S5/SDR11

- For IR, butt- and electro fusion
- Reduction factor = 0,8

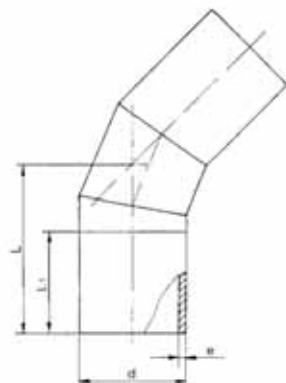

d [mm]	Code	kg	L [mm]	L1 [mm]	e [mm]
110	700 648 992	1.115	218	150	10,0
125	700 648 993	1.575	228	150	11,4
140	700 648 994	2.132	237	150	12,8
160	700 648 995	2.952	249	150	14,6
180	700 648 996	4.002	262	150	16,4
200	700 648 997	5.314	274	150	18,2
225	700 648 998	7.217	290	150	20,5
250	700 648 999	11.482	412	250	22,8
280	700 649 000	15.418	424	250	25,5
315	700 649 001	22.964	498	300	28,7
355	700 649 002	30.968	520	300	32,3
400	700 649 003	42.515	548	300	36,4
450	700 649 004	58.065	580	300	41,0
500	700 649 005	63.510	665	350	45,5
560	700 649 006	84.637	698	350	51,0
630	700 649 007	114.161	741	350	57,3

Bend 45° PE100 S8/SDR17.6

- For IR, butt- and electro fusion
- Reduction factor = 0,8

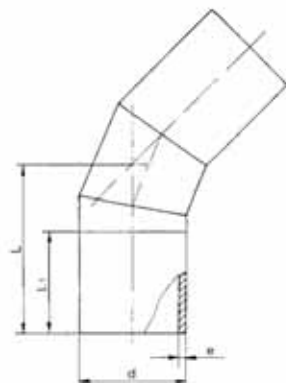

d [mm]	Code	kg	L [mm]	L1 [mm]	e [mm]
110	700 649 008	22.864	218	150	6,3
125	700 649 009	31.226	228	150	7,1
140	700 649 010	34.155	237	150	8,0
160	700 649 011	2.200	249	150	9,1
180	700 649 012	61.393	262	150	10,2
200	700 649 013	0.736	274	150	11,4
225	700 649 014	5.180	290	150	12,8
250	700 649 015	8.990	412	250	14,2
280	700 649 016	11.440	424	250	15,9

table continued next page

d [mm]	Code	kg	L [mm]	L1 [mm]	e [mm]
315	700 649 017	21.400	498	300	17,9
355	700 649 018	3.508	520	300	20,1
400	700 649 019	29.810	548	300	22,7
450	700 649 020	7.578	580	300	25,5
500	700 649 021	10.176	665	350	28,3
560	700 649 022	15.156	698	350	31,7
630	700 649 023	20.439	741	350	35,7

Bend 30° PE100 S5/SDR11

- For IR, butt- and electro fusion
- Reduction factor = 0,8

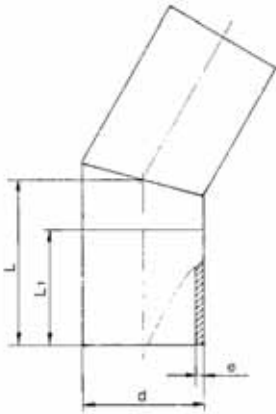

d [mm]	Code	kg	L [mm]	L1 [mm]	e [mm]
110	700 649 024	1.280	194	150	10,0
125	700 649 025	8.326	200	150	11,4
140	700 649 026	2.150	206	150	12,8
180	700 649 028	3.830	222	150	16,4
200	700 649 029	30.831	230	150	18,2
225	700 649 030	6.650	241	150	20,5
250	700 649 031	46.057	350	250	22,8
280	700 649 032	61.377	362	250	25,5
315	700 649 033	82.788	428	300	28,7
355	700 649 034	0.993	443	300	32,3
400	700 649 035	1.401	461	300	36,4
450	700 649 036	1.898	481	300	41,0
500	700 649 037	2.628	551	350	45,5
560	700 649 038	3.562	575	350	51,0
630	700 649 039	4.730	603	350	57,3

Bend 30° PE100 S8/SDR17.6

- For IR, butt- and electro fusion
- Reduction factor = 0,8

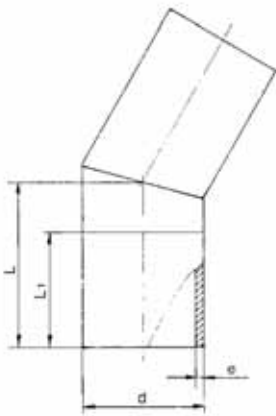

d [mm]	Code	kg	L [mm]	L1 [mm]	e [mm]
110	700 649 040	0.840	194	150	6,3
125	700 649 041	3.144	200	150	7,1
140	700 649 042	1.340	206	150	8,0
160	700 649 043	1.930	214	150	9,1
180	700 649 044	2.490	222	150	10,2
200	700 649 045	13.490	230	150	11,4
225	700 649 046	4.320	241	150	12,8
250	700 649 047	5.495	350	250	14,2
280	700 649 048	7.380	362	250	15,9
315	700 649 049	14.530	428	300	17,9
355	700 649 050	14.822	443	300	20,1
400	700 649 051	20.349	461	300	22,7
450	700 649 052	27.791	481	300	25,5
500	700 649 053	30.398	551	350	28,3
560	700 649 054	40.509	575	350	31,7
630	700 649 055	54.640	603	350	35,7

53 20 10

Tee 90° equal PE100 SDR11

- Long spigot version
- 10 bar Gas / 16 bar Water
- * With welded pipes
- * Segment welded and reinforced
- * No pressure reduction factor



d [mm]	Code	kg	z [mm]	z1 [mm]	L [mm]	e [mm]	PF
20	753 201 006	0.038	150	75	52	3,0	2 51 301 001
25	753 201 007	0.054	160	80	52	3,0	2 51 301 001
32	753 201 008	0.077	170	85	54	3,0	2 51 301 001
40	753 201 009	0.130	190	95	57	3,7	2 51 301 001
50	753 201 010	0.214	210	105	63	4,6	2 51 301 001
63	753 201 011	0.376	230	115	65	5,8	2 51 301 001
75	753 201 012	0.599	264	132	72	6,8	2 51 301 001
90	753 201 013	1.021	300	150	81	8,2	2 51 301 001
110	753 201 014	1.612	330	165	86	10,0	2 51 301 001
125	753 201 015	2.420	366	183	92	11,4	2 51 301 001
140	753 201 016	3.090	393	193	92	12,7	2 51 301 001
160	753 201 017	4.403	420	210	102	14,6	2 51 301 001
180	753 201 018	6.014	460	230	107	16,4	2 51 301 001
200	753 201 019	8.480	500	250	117	18,2	2 51 301 001
225	753 201 020	11.507	540	270	122	20,5	2 51 301 001
250	753 201 001	14.099	575	288	130	22,7	2 51 301 002
280	753 200 902	18.670	615	308	139	25,4	2 51 301 002
315	753 200 903	26.150	695	346	150	28,6	2 51 301 002
355	753 200 904	39.800	818	410	165	32,3	2 51 301 008
400	753 200 905	42.495	910	455	180	36,4	2 51 301 008
450	753 200 906	77.300	970	485	195	40,9	2 51 301 008
500	753 200 907	101.000	1060	530	215	45,5	2 51 301 008
* 560	753 200 908	153.300	1510	755	230	50,9	2 51 301 008
* 630	753 200 909	205.500	1630	815	250	57,3	2 51 301 008
* 710	753 201 120	318.698	1720	860	450	64,5	2 51 301 008
* 800	753 201 121	409.142	1780	890	450	72,6	2 51 301 008

53 20 08

Tee 90° equal PE100 SDR17/17,6

- Long spigot version
- 5 bar Gas / 10 bar Water
- * Segment welded and reinforced
- * With welded pipes
- * No pressure reduction factor

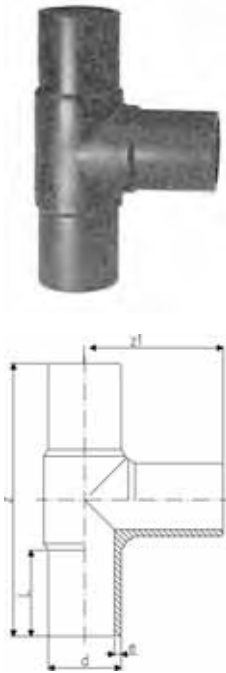

d [mm]	Code	kg	z [mm]	z1 [mm]	L [mm]	e [mm]	PF
90	753 200 813	0.777	300	150	80	5,4	2 51 301 001
110	753 200 814	1.231	330	165	86	6,6	2 51 301 001
125	753 200 815	1.690	366	183	92	7,4	2 51 301 001
140	753 200 816	2.202	396	196	92	8,3	2 51 301 001
160	753 200 817	3.201	428	214	104	9,5	2 51 301 001
180	753 200 818	4.287	460	230	105	10,7	2 51 301 001
200	753 200 819	5.889	500	250	115	11,9	2 51 301 001
225	753 200 820	7.886	540	270	122	13,4	2 51 301 001
250	753 200 821	10.000	575	288	130	14,8	2 51 301 002
280	753 200 802	13.350	615	308	139	16,6	2 51 301 002
315	753 200 803	17.985	695	346	150	18,7	2 51 301 002
355	753 200 804	25.850	818	410	165	21,1	2 51 301 008
400	753 200 805	35.015	910	455	180	23,7	2 51 301 008
450	753 200 806	56.000	970	485	195	26,7	2 51 301 008
500	753 200 807	71.000	1060	530	215	29,7	2 51 301 008
* 560	753 200 808	99.200	1510	755	230	33,2	2 51 301 008
* 630	753 200 809	132.700	1630	815	250	37,4	2 51 301 008
* 710	753 201 920	219.870	1720	860	450	42,1	2 51 301 008
* 800	753 201 921	281.495	1780	890	450	47,4	2 51 301 008

53 20 08

Tee 90° equal PE100 SDR17/17,6**Model:**

- Long spigot
- Conventional butt-welding according to DVS 2207 part 1
- Production process: segment welded
- Does not conform to pressure rating. Pressure reduction factor of 0.5
- 5 bar water

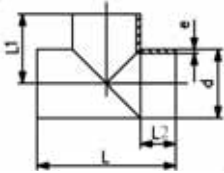

d [mm]	Code	kg	L [mm]	L1 [mm]	L2 [mm]	e [mm]
710	753 202 810	158.180	1410	705	350	42.1
800	753 202 811	210.302	1500	750	350	47.4
900	753 202 812	302.118	1700	850	400	53.3
1000	753 202 813	457.054	2040	1020	520	59.3

53 20 10

Tee 90° reduced moulded PE100 SDR11

- Long spigot version
- 10 bar Gas / 16 bar Water

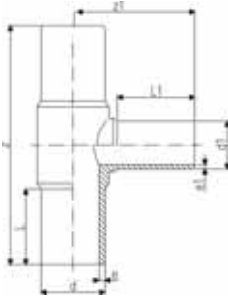

d [mm]	d1 [mm]	Code	kg	z [mm]	z1 [mm]	L [mm]	L1 [mm]	e [mm]	e1 [mm]
63	50	753 201 044	0.305	215	103	63	56	5.8	4.6
75	32	753 201 045	0.519	256	108	70	46	6.8	2.9
75	50	753 201 046	0.531	253	113	70	56	6.8	4.6
75	63	753 201 047	0.554	255	117	70	63	6.8	5.8
90	50	753 201 027	0.794	280	117	79	55	8.2	4.6
90	63	753 201 029	0.775	280	123	79	63	8.2	5.8
90	75	753 201 030	0.779	272	138	73	68	8.2	6.8
110	63	753 201 028	1.409	320	147	87	63	10.0	5.8
110	75	753 201 031	1.221	309	151	82	70	10.0	6.8
110	90	753 201 032	1.275	320	158	86	79	10.0	8.2
125	90	753 201 048	1.717	340	170	112	92	11.4	8.2
125	110	753 201 033	1.909	341	170	90	83	11.4	10.0
160	63	753 201 034	2.680	416	176	98	65	14.6	5.8
160	75	753 201 035	2.676	343	180	98	74	14.6	6.8
160	90	753 201 036	2.775	412	188	101	79	14.6	8.2
160	110	753 201 037	3.300	412	195	101	82	14.6	10.0
180	90	753 201 049	4.410	420	200	136	97	16.4	8.2
180	110	753 201 050	4.379	430	206	130	101	16.4	10.0
180	160	753 201 038	4.715	411	205	105	94	16.4	14.6
200	63	753 201 073	7.300	500	190	122	63	18.2	5.8
200	90	753 201 074	9.730	500	207	122	79	18.2	8.2
200	110	753 201 075	7.120	500	215	122	82	18.2	10.0
200	160	753 201 076	9.730	500	234	122	98	18.2	14.6
225	75	753 201 039	9.880	555	215	120	70	20.5	6.8
225	90	753 201 040	6.633	558	226	120	80	20.5	8.2
225	110	753 201 041	10.010	558	235	120	82	20.5	10.0
225	160	753 201 042	8.095	560	253	120	98	20.5	14.6
225	180	753 201 043	9.375	560	280	120	105	20.5	16.4
250	110	753 201 078	11.820	575	242	130	82	22.7	10.0
250	160	753 201 079	12.302	575	261	127	98	22.7	14.6
315	110	753 201 051	15.300	695	277	150	82	28.6	10.0
315	160	753 201 052	22.998	695	296	150	102	28.6	14.6
315	225	753 201 053	20.011	650	335	170	145	28.6	20.5
315	250	753 201 054	24.243	695	325	150	130	28.6	22.7

53 20 08

Tee 90° reduced, moulded PE100 SDR17/17,6

- Long spigot version
- 5 bar Gas / 10 bar Water



d [mm]	d1 [mm]	Code	kg	z [mm]	z1 [mm]	L [mm]	L1 [mm]	e [mm]	e1 [mm]	e1 [mm]
90	50	753 201 827	0.630	275	117	79	55	5.4	3,0	3,0
90	63	753 200 829	0.560	275	123	79	63	5.4	3,8	3,8
90	75	753 200 830	0.593	272	139	74	71	5.4	4,5	4,5
110	63	753 200 828	1.010	318	147	82	63	6.6	3,8	3,8
110	75	753 200 831	0.891	315	152	84	70	6.6	4,5	4,5
110	90	753 200 832	0.941	318	158	82	79	6.6	5,4	5,4
125	110	753 200 833	1.399	334	168	84	83	7.4	6,6	6,6
160	63	753 200 834	1.950	330	130	86	63	9.5	3,8	3,8
160	75	753 200 835	1.932	343	180	98	74	9.5	4,5	4,5
160	90	753 200 836	1.972	410	188	98	79	9.5	5,4	5,4
160	110	753 200 837	2.716	410	195	98	82	9.5	6,6	6,6
180	90	753 200 844	3.250	422	204	134	97	10.7	5,4	5,4
180	160	753 200 838	3.557	411	205	105	94	10.7	9,5	9,5
200	63	753 201 873	6.800	500	190	122	63	11.9	3,8	3,8
200	90	753 201 874	6.900	500	207	122	79	11.9	5,4	5,4
200	110	753 201 875	5.097	500	215	122	82	11.9	6,6	6,6
200	160	753 201 876	7.400	500	234	122	98	11.9	9,5	9,5
225	75	753 200 839	7.128	555	277	120	70	13.4	4,5	4,5
225	90	753 200 840	4.732	555	226	127	80	13.4	5,4	5,4
225	110	753 200 841	4.700	555	235	127	82	13.4	6,6	6,6
225	160	753 200 842	5.922	555	253	127	98	13.4	9,5	9,5
225	180	753 200 843	7.211	550	280	120	105	13.4	10,7	10,7
250	110	753 201 878	9.400	575	242	130	82	14.8	6,6	6,6
250	160	753 201 879	9.800	575	261	130	98	14.8	9,5	9,5
315	110	753 200 851	15.621	695	277	150	82	18.7	6,6	6,6
315	160	753 200 852	12.200	695	296	150	102	18.7	9,5	9,5
315	225	753 200 853	14.869	650	335	170	145	18.7	13,4	13,4
315	250	753 200 854	15.500	695	325	150	130	18.7	14,8	14,8

53 20 10

Tee 90° reduced with welded reducer

- PE 100 SDR 11 (ISO S5)
- 10 bar Gas / 16 bar Water



d [mm]	d1 [mm]	Code	kg	z [mm]	z1 [mm]	L [mm]	L1 [mm]	e [mm]	e1 [mm]
25	20	753 201 002	0.053	160		52	52	3,0	3,0
32	20	753 201 003	0.094	170	105	54	52	3,0	3,0
32	25	753 201 004	0.098	170	110	54	52	3,0	3,0
40	20	753 201 005	0.124	190	120	57	52	3,7	3,0
40	25	753 201 069	0.160	190	120	57	52	3,7	3,0
40	32	753 201 070	0.160	190	120	57	52	3,7	3,0
50	20	753 201 072	0.252	210	140	63	52	4,6	3,0
50	25	753 201 077	0.260	210	130	63	52	4,6	3,0
50	32	753 201 080	0.207	210	130	63	53	4,6	3,0
50	40	753 201 081	0.224	210	130	63	57	4,6	3,7
63	32	753 201 082	0.359	230	140	65	53	5,8	3,0
63	40	753 201 116	0.480	230	145	65	57	5,8	3,7
75	40	753 201 084	0.603	264	180	72	57	6,8	3,7
125	63	753 201 085	2.359	366	225	92	61	11,4	5,8
125	75	753 201 086	2.434	366	235	92	72	11,4	6,8
140	75	753 201 087	3.038	396	230	92	70	12,7	6,8
140	90	753 201 089	3.092	396	235	92	79	12,7	8,2
140	110	753 201 090	3.600	396	240	92	82	12,7	10,0
140	125	753 201 091	4.170	396	240	92	90	12,7	11,4
160	125	753 201 092	4.544	420	265	102	92	14,6	11,4
160	140	753 201 093	5.895	420	270	102	96	14,6	12,7
180	125	753 201 094	6.111	460	285	107	92	16,4	11,4
180	140	753 201 095	6.317	460	295	107	110	16,4	12,7
200	125	753 201 096	8.424	500	295	117	92	18,2	11,4
200	140	753 201 097	10.570	500	310	117	110	18,2	12,7

table continued next page

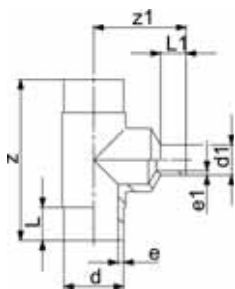

d [mm]	d1 [mm]	Code	kg	z [mm]	z1 [mm]	L [mm]	L1 [mm]	e [mm]	e1 [mm]
200	180	753 201 098	9.031	500	310	117	110	18,2	16,4
225	125	753 201 099	11.260	540	320	122	92	20,5	11,4
225	140	753 201 100	14.574	540	335	122	110	20,5	12,7
225	200	753 201 101	14.925	540	340	122	117	20,5	18,2
250	180	753 201 102	14.327	576	350	130	105	22,7	16,4
250	200	753 201 103	19.220	576	360	130	112	22,7	18,2
250	225	753 201 104	15.240	576	390	130	120	22,7	20,5
280	200	753 201 105	24.520	616	410	139	112	25,4	18,2
280	225	753 201 106	24.755	616	420	139	120	25,4	20,5
280	250	753 201 107	25.210	616	420	139	130	25,4	22,7
315	200	753 201 108	33.950	690	470	150	134	28,6	18,2
315	280	753 201 109	34.950	690	480	150	139	28,6	25,4
355	250	753 201 110	48.900	818	530	165	130	32,3	22,7
355	280	753 201 111	49.300	818	480	165	139	32,3	25,4
355	315	753 201 112	49.690	818	480	165	150	32,3	28,6
400	280	753 201 113	52.915	910	530	180	139	36,4	25,4
400	315	753 201 114	53.625	910	580	180	150	36,4	28,6
400	355	753 201 115	54.075	910	675	180	165	36,4	32,3

Tee 90° reduced with welded reducer PE100 SDR17/17,6

• 5 bar Gas / 10 bar Water

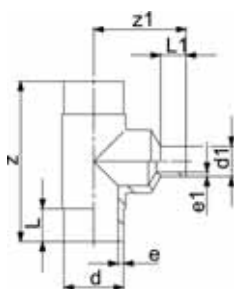

d [mm]	d1 [mm]	Code	kg	z [mm]	z1 [mm]	L [mm]	L1 [mm]	e [mm]	e1 [mm]
125	63	753 200 801	2.115	366	215	92	61	7.4	3.8
125	75	753 200 810	1.806	366	235	92	72	7.4	4.5
125	90	753 200 811	1.712	366	235	92	80	7.4	5.4
140	75	753 200 812	2.820	396	240	92	70	8.3	4.5
140	90	753 200 822	2.211	396	240	92	78	8.3	5.4
140	110	753 200 823	2.266	396	235	92	82	8.3	6.6
140	125	753 200 824	2.317	396	240	92	87	8.3	7.4
160	125	753 200 825	3.311	428	265	104	90	9.5	5.4
160	140	753 200 826	3.416	428	280	104	96	9.5	8.3
180	110	753 200 827	4.410	460	285	105	92	10.7	6.6
180	125	753 200 845	4.460	460	285	105	90	10.7	7.4
180	140	753 200 846	4.483	460	305	105	110	10.7	8.3
200	125	753 200 847	5.886	500	310	115	92	11.9	7.4
200	140	753 200 848	7.200	500	315	115	110	11.9	8.3
200	180	753 200 849	6.900	500	315	115	110	11.9	10.7
225	125	753 200 850	7.937	540	320	122	92	13.4	7.4
225	140	753 200 855	8.780	540	345	122	110	13.4	8.3
225	200	753 200 856	9.064	540	335	122	115	13.4	11.9
250	180	753 200 857	15.000	576	340	130	105	14.8	10.7
250	200	753 200 858	15.440	576	350	130	112	14.8	11.9
250	225	753 200 859	15.620	576	370	130	120	14.8	13.4
280	200	753 200 860	19.200	616	400	139	112	16.6	11.9
280	225	753 200 861	19.500	616	400	139	120	16.6	13.4
280	250	753 200 862	20.120	616	400	139	130	16.6	14.8
315	200	753 200 863	18.700	690	480	150	134	18.7	11.9
315	280	753 200 864	26.940	690	480	150	139	18.7	16.6
355	250	753 200 865	35.770	818	480	165	130	21.1	14.8
355	280	753 200 866	36.330	818	480	165	139	21.1	16.6
355	315	753 200 867	37.740	818	490	165	150	21.1	18.7
400	280	753 200 868	48.330	910	540	180	139	23.7	16.6
400	315	753 200 869	48.880	910	580	180	150	23.7	18.7
400	355	753 200 870	50.020	910	675	180	165	23.7	21.1

53 25 10

Tee 45° equal PE100 SDR11

- Long spigot version
- 10 bar Gas / 16 bar Water

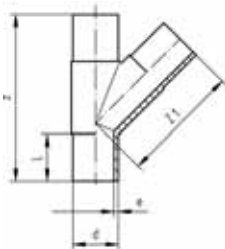

d [mm]	Code	kg	z [mm]	z1 [mm]	L [mm]	e [mm]
63	753 251 011	0.463	255	158	63	5,8
75	753 251 012	0.800	301	190	70	6,8
90	753 251 013	1.373	368	234	79	8,2
110	753 251 014	1.800	395	260	82	10,0

53 25 10

Tee 45° equal PE100 SDR17/17,6

- 5 bar Gas / 10 bar Water

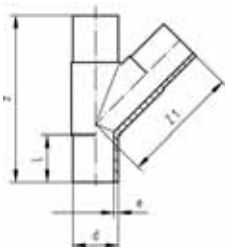

d [mm]	Code	kg	z [mm]	z1 [mm]	L [mm]	e [mm]
90	753 251 063	0.800	368	234	79	5,4
110	753 251 064	1.400	395	260	82	6,6

Reducer PE100 SDR11

- Long spigot version
- 10 bar Gas / 16 bar Water

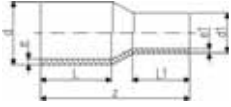

d [mm]	d1 [mm]	Code	kg	z [mm]	L [mm]	L1 [mm]	e [mm]	e1 [mm]	PF
25	20	753 901 038	0.022	115	52	52	3,0	3,0	2 51 301 001
32	20	753 901 042	0.027	120	54	52	3,0	3,0	2 51 301 001
32	25	753 901 041	0.033	120	54	52	3,0	3,0	2 51 301 001
40	20	753 901 048	0.043	129	57	52	3,7	3,0	2 51 301 001
40	25	753 901 047	0.045	129	57	52	3,7	3,0	2 51 301 001
40	32	753 901 046	0.047	129	57	53	3,7	3,0	2 51 301 001
50	20	753 901 055	0.064	149	63	52	4,6	3,0	2 51 301 001
50	25	753 901 054	0.069	139	63	52	4,6	3,0	2 51 301 001
50	32	753 901 053	0.067	140	63	53	4,6	3,0	2 51 301 001
50	40	753 901 052	0.079	139	63	57	4,6	3,7	2 51 301 001
63	32	753 901 060	0.113	149	65	53	5,8	3,0	2 51 301 001
63	40	753 901 059	0.122	150	65	57	5,8	3,7	2 51 301 001
63	50	753 901 058	0.128	150	65	63	5,8	4,6	2 51 301 001
75	40	753 901 063	0.185	170	72	57	6,8	3,7	2 51 301 001
75	50	753 901 064	0.188	170	72	63	6,8	4,6	2 51 301 001
75	63	753 901 065	0.209	170	72	65	6,8	5,8	2 51 301 001
90	50	753 901 072	0.289	190	81	63	8,2	4,6	2 51 301 001
90	63	753 901 071	0.316	190	81	65	8,2	5,8	2 51 301 001
90	75	753 901 070	0.351	190	81	70	8,2	6,8	2 51 301 001
110	63	753 901 078	0.471	205	86	65	10,0	5,8	2 51 301 001
110	75	753 901 077	0.501	205	86	70	10,0	6,8	2 51 301 001
110	90	753 901 076	0.549	205	86	81	10,0	8,2	2 51 301 001
125	63	753 901 083	0.607	214	87	63	11,4	5,8	2 51 301 001
125	75	753 901 082	0.667	210	92	72	11,4	6,8	2 51 301 001
125	90	753 901 081	0.683	212	92	81	11,4	8,2	2 51 301 001
125	110	753 901 080	0.775	212	92	86	11,4	10,0	2 51 301 001
140	75	753 901 086	0.910	230	110	70	12,7	6,8	2 51 301 001
140	90	753 901 087	0.954	230	110	79	12,7	8,2	2 51 301 001
140	110	753 901 084	0.977	234	110	88	12,7	10,0	2 51 301 001
140	125	753 901 085	1.078	235	110	90	12,7	11,4	2 51 301 001
160	90	753 901 088	1.164	244	120	79	14,6	8,2	2 51 301 001
160	110	753 901 090	1.239	244	102	86	14,6	10,0	2 51 301 001
160	125	753 901 089	1.333	245	102	92	14,6	11,4	2 51 301 001
160	140	753 901 032	1.522	260	120	110	14,6	12,7	2 51 301 001
180	90	753 901 073	1.507	245	105	79	16,4	8,2	2 51 301 001
180	110	753 901 074	1.833	270	105	82	16,4	10,0	2 51 301 001
180	125	753 901 091	1.723	258	107	92	16,4	11,4	2 51 301 001
180	140	753 901 075	1.976	270	120	110	16,4	12,7	2 51 301 001
180	160	753 901 033	1.968	255	107	102	16,4	14,6	2 51 301 001
200	140	753 901 066	2.326	275	120	110	18,2	12,7	2 51 301 001
200	160	753 901 092	2.422	265	117	102	18,2	14,6	2 51 301 001
200	180	753 901 034	2.724	265	117	107	18,2	16,4	2 51 301 001
225	140	753 901 067	2.900	295	130	110	20,5	12,7	2 51 301 001
225	160	753 901 096	2.891	279	122	102	20,5	14,6	2 51 301 001
225	180	753 901 095	3.244	280	122	107	20,5	16,4	2 51 301 001
225	200	753 901 094	3.538	280	122	117	20,5	18,2	2 51 301 001
250	160	753 901 000	2.385	300	130	100	22,7	14,6	2 51 301 002
250	180	753 901 068	4.299	295	130	105	22,7	16,4	2 51 301 002
250	200	753 901 001	4.766	315	130	112	22,7	18,2	2 51 301 002
250	225	753 901 002	2.385	332	130	120	22,7	20,5	2 51 301 002
280	200	753 901 098	6.850	333	140	112	25,4	18,2	2 51 301 002
280	225	753 901 099	6.112	335	140	120	25,4	20,5	2 51 301 002
280	250	753 901 003	2.385	340	140	130	25,4	22,7	2 51 301 002
315	200	753 901 004	7.522	380	180	134	28,6	18,2	2 51 301 002
315	225	753 901 097	7.790	365	150	120	28,6	20,5	2 51 301 002
315	250	753 901 005	8.360	365	150	130	28,6	22,7	2 51 301 002
315	280	753 901 012	8.800	365	150	139	28,6	25,4	2 51 301 002
355	250	753 901 013	9.100	390	165	130	32,3	22,7	2 51 301 008
355	280	753 901 014	9.500	390	165	139	32,3	25,4	2 51 301 008
355	315	753 901 015	9.900	390	165	150	32,3	28,6	2 51 301 008
400	280	753 901 016	10.420	415	180	139	36,4	25,4	2 51 301 008
400	315	753 901 017	11.130	415	180	150	36,4	28,6	2 51 301 008

table continued next page

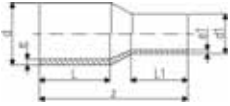

d [mm]	d1 [mm]	Code	kg	z [mm]	L [mm]	L1 [mm]	e [mm]	e1 [mm]	PF
400	355	753 901 018	11.600	420	180	165	36,4	32,3	2 51 301 008
450	280	753 901 019	16.200	389	195	139	40,9	25,4	2 51 301 008
450	315	753 901 020	16.700	390	195	150	40,9	28,6	2 51 301 008
450	355	753 901 022	17.500	393	195	164	40,9	32,3	2 51 301 008
450	400	753 901 024	18.500	395	195	179	40,9	36,4	2 51 301 008
500	315	753 901 025	21.900	422	212	150	45,5	28,6	2 51 301 008
500	355	753 901 026	22.600	424	212	164	45,5	32,3	2 51 301 008
500	400	753 901 027	23.600	426	212	179	45,5	36,4	2 51 301 008
500	450	753 901 029	25.100	428	212	195	45,5	40,9	2 51 301 008
560	355	753 901 030	30.100	459	230	164	50,9	32,3	2 51 301 008
560	400	753 901 039	31.000	461	230	179	50,9	36,4	2 51 301 008
560	450	753 901 040	32.400	463	230	195	50,9	40,9	2 51 301 008
560	500	753 901 043	34.100	466	230	212	50,9	45,5	2 51 301 008
630	400	753 901 044	41.900	502	250	179	57,3	36,4	2 51 301 008
630	450	753 901 045	43.100	503	250	195	57,3	40,9	2 51 301 008
630	500	753 901 049	44.700	506	250	212	57,3	45,5	2 51 301 008
630	560	753 901 050	46.800	506	250	230	57,3	50,9	2 51 301 008

Reducer PE100 SDR17/17,6

- Long spigot version
- 5 bar Gas / 10 bar Water



d [mm]	d1 [mm]	Code	kg	z [mm]	L [mm]	L1 [mm]	e [mm]	e1 [mm]	PF
90	63	753 900 872	0.224	182	79	70	5,4	3,8	2 51 301 001
90	75	753 900 870	0.234	185	79	70	5,4	4,5	2 51 301 001
110	63	753 900 877	0.326	185	82	63	6,6	3,8	2 51 301 001
110	90	753 900 876	0.333	205	85	80	6,6	5,4	2 51 301 001
125	63	753 900 882	0.610	200	87	63	7,4	3,8	2 51 301 001
125	90	753 900 881	0.461	215	90	80	7,4	5,4	2 51 301 001
125	110	753 900 880	0.507	215	90	85	7,4	6,6	2 51 301 001
140	75	753 900 886	0.560	230	112	70	8,3	4,5	2 51 301 001
140	90	753 900 887	0.642	230	112	79	8,3	5,4	2 51 301 001
140	110	753 900 884	0.715	230	112	82	8,3	6,6	2 51 301 001
140	125	753 900 885	0.754	235	115	87	8,3	7,4	2 51 301 001
160	90	753 900 888	0.752	248	120	85	9,5	5,4	2 51 301 001
160	110	753 900 890	0.930	245	100	85	9,5	6,6	2 51 301 001
160	125	753 900 889	0.930	245	100	90	9,5	7,4	2 51 301 001
160	140	753 900 831	0.995	260	120	110	9,5	8,3	2 51 301 001
180	90	753 900 873	1.010	237	105	79	10,7	5,4	2 51 301 001
180	110	753 900 874	1.600	270	120	92	10,7	6,6	2 51 301 001
180	125	753 900 891	1.165	255	105	90	10,7	7,4	2 51 301 001
180	140	753 900 875	1.720	270	120	110	10,7	8,3	2 51 301 001
180	160	753 900 832	2.100	255	105	100	10,7	9,5	2 51 301 001
200	140	753 900 866	1.800	275	120	110	11,9	8,3	2 51 301 001
200	160	753 900 892	1.664	265	115	100	11,9	9,5	2 51 301 001
200	180	753 900 893	2.580	265	115	105	11,9	10,7	2 51 301 001
225	140	753 900 867	2.021	280	120	100	13,4	8,3	2 51 301 001
225	160	753 900 896	2.020	280	120	100	13,4	9,5	2 51 301 001
225	180	753 900 895	2.240	280	120	105	13,4	10,7	2 51 301 001
225	200	753 900 894	2.237	280	120	115	13,4	11,9	2 51 301 001
250	160	753 900 800	2.850	290	130	100	14,8	9,5	2 51 301 002
250	180	753 900 868	3.100	295	130	105	14,8	10,7	2 51 301 002
250	200	753 900 801	3.210	302	130	112	14,8	11,9	2 51 301 002
250	225	753 900 802	2.385	332	162	120	14,8	13,4	2 51 301 002
280	200	753 900 898	3.800	333	140	112	16,6	11,9	2 51 301 002
280	225	753 900 899	4.100	335	140	120	16,6	13,4	2 51 301 002
280	250	753 900 803	4.352	340	140	130	16,6	14,8	2 51 301 002
315	200	753 900 804	5.390	380	180	134	18,7	11,9	2 51 301 002
315	225	753 900 807	6.200	365	150	120	18,7	13,4	2 51 301 002
315	250	753 900 805	6.420	365	150	130	18,7	14,8	2 51 301 002
315	280	753 900 806	5.940	365	150	140	18,7	16,6	2 51 301 002
355	250	753 900 808	7.082	390	165	130	21,1	14,8	2 51 301 008
355	280	753 900 809	6.728	390	165	140	21,1	16,6	2 51 301 008
355	315	753 900 810	7.240	390	165	150	21,1	18,7	2 51 301 008
400	280	753 900 811	7.930	415	180	140	23,7	16,6	2 51 301 008
400	315	753 900 812	9.949	415	180	150	23,7	18,7	2 51 301 008
400	355	753 900 813	9.620	420	180	165	23,7	21,1	2 51 301 008
450	280	753 900 814	11.500	389	195	140	26,7	16,6	2 51 301 008
450	315	753 900 815	11.805	390	195	150	26,7	18,7	2 51 301 008
450	355	753 900 816	11.900	393	195	164	26,7	21,1	2 51 301 008
450	400	753 900 817	12.964	395	195	179	26,7	23,7	2 51 301 008
500	315	753 900 818	15.500	422	212	150	29,7	18,7	2 51 301 008
500	355	753 900 819	15.700	424	212	164	29,7	21,1	2 51 301 008
500	400	753 900 820	16.200	426	212	179	29,7	23,7	2 51 301 008
500	450	753 900 821	17.000	428	212	195	29,7	26,7	2 51 301 008
560	355	753 900 822	21.400	459	230	164	33,2	21,1	2 51 301 008
560	400	753 900 823	21.700	461	230	179	33,2	23,7	2 51 301 008
560	450	753 900 824	22.300	463	230	195	33,2	26,7	2 51 301 008
560	500	753 900 825	23.200	466	230	212	33,2	29,7	2 51 301 008
630	400	753 900 826	29.700	502	250	179	37,4	23,7	2 51 301 008
630	450	753 900 827	30.100	503	250	195	37,4	26,7	2 51 301 008
630	500	753 900 828	30.800	506	250	212	37,4	29,7	2 51 301 008
630	560	753 900 829	31.900	506	250	230	37,4	33,3	2 51 301 008
710	500	753 900 833	58.796	790	300	300	42,1	29,7	2 51 301 008
710	560	753 900 834	60.578	770	300	300	42,1	33,2	2 51 301 008

table continued next page

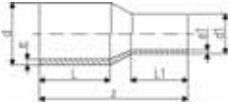

d [mm]	d1 [mm]	Code	kg	z [mm]	L [mm]	L1 [mm]	e [mm]	e1 [mm]	PF
710	630	753 900 835	62.448	740	300	300	42,1	37,4	2 51 301 008
800	560	753 900 836	75.842	800	300	300	47,4	33,2	2 51 301 008
800	630	753 900 837	78.255	780	300	300	47,4	37,4	2 51 301 008
800	710	753 900 838	80.504	750	300	300	47,4	42,1	2 51 301 008
900	630	753 900 839	99.282	820	300	300	53,3	37,4	2 51 301 008
900	710	753 900 840	100.908	790	300	300	53,3	42,1	2 51 301 008
900	800	753 900 841	103.578	760	300	300	53,3	47,4	2 51 301 008
1000	710	753 900 842	124.232	820	300	300	59,3	42,1	2 51 301 008
1000	800	753 900 843	125.277	780	300	300	59,3	47,4	2 51 301 008
1000	900	753 900 844	126.638	740	300	300	59,3	53,3	2 51 301 008

53 96 10

Cap PE100 SDR11

- Long spigot version
- 10 bar Gas / 16 bar Water

Note:

* Fabricated fitting made from pipe

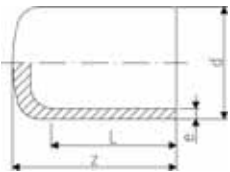

d [mm]	Code	kg	z [mm]	L [mm]	e [mm]	PF
20	753 961 006	0.010	52	52	3,0	2 51 301 001
25	753 961 007	0.015	52	52	3,0	2 51 301 001
32	753 961 008	0.020	54	54	3,0	2 51 301 001
40	753 961 009	0.033	57	57	3,7	2 51 301 001
50	753 961 010	0.054	63	63	4,6	2 51 301 001
63	753 961 011	0.086	65	65	5,8	2 51 301 001
75	753 961 012	0.146	80	72	6,8	2 51 301 001
90	753 961 013	0.240	90	81	8,2	2 51 301 001
110	753 961 014	0.373	98	86	10,0	2 51 301 001
125	753 961 015	0.546	105	92	11,4	2 51 301 001
140	753 961 016	0.727	136	92	12,7	2 51 301 001
160	753 961 017	1.034	120	102	14,6	2 51 301 001
180	753 961 018	1.351	128	107	16,4	2 51 301 001
200	753 961 019	1.845	138	115	18,2	2 51 301 001
225	753 961 020	2.514	148	122	20,5	2 51 301 001
250	753 961 021	3.927	205	130	22,7	2 51 301 002
280	753 960 922	8.045	235	139	25,4	2 51 301 002
315	753 960 923	6.861	255	150	28,6	2 51 301 002
355	753 960 924	9.780	280	165	32,3	2 51 301 008
400	753 960 925	13.370	310	180	36,4	2 51 301 008
* 450	753 960 926	20.800	275	195	40,9	2 51 301 008
* 500	753 960 927	28.400	297	212	45,5	2 51 301 008
* 560	753 960 928	39.100	325	230	50,9	2 51 301 008
* 630	753 960 929	59.700	355	250	57,3	2 51 301 008

53 96 08

Cap PE100 SDR17/17,6

- Long spigot version
- 5 bar Gas / 10 bar Water

Note:

* Fabricated fitting made from pipe

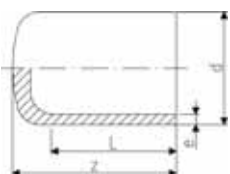

d [mm]	Code	kg	z [mm]	L [mm]	e [mm]	PF
50	753 960 810	0.036	70	55	3,0	2 51 301 001
63	753 960 811	0.058	82	63	3,8	2 51 301 001
75	753 960 812	0.105	92	70	4,5	2 51 301 001
90	753 960 813	0.214	90	81	5,4	2 51 301 001
110	753 960 814	0.272	98	86	6,6	2 51 301 001
125	753 960 815	0.487	105	92	7,4	2 51 301 001
140	753 960 816	0.481	136	92	8,3	2 51 301 001
160	753 960 817	0.920	120	102	9,5	2 51 301 001
180	753 960 818	1.216	128	107	10,7	2 51 301 001
200	753 960 819	1.687	138	115	11,9	2 51 301 001
225	753 960 820	2.265	148	122	13,4	2 51 301 001
250	753 960 821	2.547	205	130	14,8	2 51 301 002

table continued next page

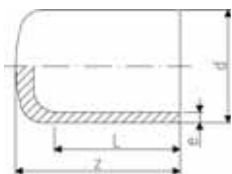

d [mm]	Code	kg	z [mm]	L [mm]	e [mm]	PF
280	753 960 822	3.523	235	139	16,6	2 51 301 002
315	753 960 823	4.758	255	150	18,7	2 51 301 002
355	753 960 824	6.510	280	165	21,1	2 51 301 008
400	753 960 825	9.347	310	180	23,7	2 51 301 008
* 450	753 960 826	17.798	265	195	26,7	2 51 301 008
* 500	753 960 827	21.400	287	212	29,7	2 51 301 008
* 560	753 960 828	29.400	310	230	33,2	2 51 301 008
* 630	753 960 829	41.400	340	250	37,4	2 51 301 008
* 710	753 960 830	53.950	310	190	42,1	2 51 301 008
* 800	753 960 831	73.281	320	190	47,4	2 51 301 008
* 900	753 960 832	98.923	330	190	53,5	2 51 301 008
* 1000	753 960 833	123.925	340	190	59,3	2 51 301 008

























Transition fittings PE/steel

- PE 100 SDR 11 (ISO S5)
- 6 bar Gas / 16 bar Water
- Electrofusion weldable
- Steel pipe acc. to EN 10208-1, PE coated for corrosion resistance
- * Steel pipe without plastic shroud

d [mm]	d1 [inch]	Code	kg	d [mm]	L [mm]	L1 [mm]	L2 [mm]
* 20	½	775 641 502	0.450	20	427	35	41
25	¾	775 641 507	0.658	25	462	35	41
32	1	775 641 510	0.988	32	462	35	44
40	1 ¼	775 641 514	1.208	40	470	35	49
50	1 ½	775 641 518	1.355	50	475	35	55
63	2	775 641 524	2.011	63	480	35	63
75	2 ½	775 641 632	2.983	75	545	35	70
90	3	775 641 636	3.762	90	562	45	79
110	3	775 641 640	4.381	110	580	45	82
110	4	775 641 641	6.633	110	580	45	82
125	4	775 641 645	6.833	125	584	45	87
160	6	775 641 655	12.406	160	607	45	98
180	6	775 641 659	11.935	180	605	45	105
200	8	775 642 664	19.647	200	615	45	112
225	8	775 642 669	20.154	225	620	45	120
250	8	775 642 665	21.354	250	640	45	129
250	10	775 642 666	30.000	250	645	45	129
280	10	775 642 673	31.000	280	637	45	139
315	12	775 642 672	35.000	315	730	45	150
355	12	775 642 675	49.000	355	732	45	164
400	16	775 642 678	94.000	400	770	45	179

Accessories and Spare parts

		Page
	Pipe Clips	487
	Spare parts ball valves	490
	Spare parts butterfly valves	517
	Spare parts diaphragm valves new generation	527
	Spare parts diaphragm valves	535
	Spare parts comprehensive	547
	Spare parts line strainer	551
	Spare parts cone check valves	555
	Spare parts ball check valves	558
	Spare parts ventilating- and bleed valves	562
	Spare parts wafer check valves	566
	Spare parts solenoid valves	568
	Spare parts variable area flow meters	570

		Page
	Pneumatic rotary actuators PA	579
	Accessories for pneumatic rotary actuators	583
	Electric actuators	585
	Accessories for electric actuators	586
	Pneumatic stroke actuators	589
	Accessories for pneumatic stroke actuators	594
	Pilot valves	595
	Position indicator	602
	Controllers	603
	AS-Interface	606
	Seals	609

Pipe Clips

KLIP-IT pipe clip type 061H PP metric

Model:

- Material: Clip and safety clip PP black, UV resistant, bolts galvanized
- **Minimum order quantity: standard packagings SP**
- d16 - d63: height designed for Ball Valve Type 546 und 543
- * d16 to d32 without bracket

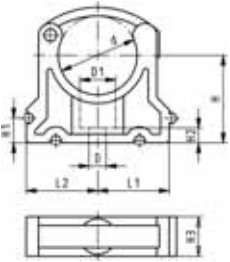

d [mm]	Code	D [mm]	D1 [mm]	L1 [mm]	L2 [mm]	H [mm]	H1 [mm]	H2 [mm]	H3 [mm]	HoH +/- 2mm [mm]	SC
* 16	167 061 035	6	11	14	17	27	10	6	16	17.0	M5
* 20	167 061 036	6	11	17	19	27	10	6	16	21.4	M5
* 25	167 061 037	6	11	19	22	30	10	6	16	26.9	M5
* 32	167 061 038	6	11	24	27	36	10	6	16	36.7	M5
40	167 061 039	7	14	34	34	44	10	7	22	44.4	M6
50	167 061 040	7	14	37	37	51	10	7	22	52.3	M6
63	167 061 041	9	17	45	45	64	10	10	25	66.7	M8

KLIP-IT Pipe Clips Type 061, PP metric

Model:

- Material: Clip and safety clip PP black, UV resistant, bolts galvanized
- d16 - d63: Height designed for Ball Valve Type 546 and 543
- **Minimum order quantity: standard packagings SP**

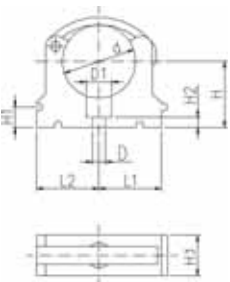

d [mm]	d [inch]	Code	D [mm]	D1 [mm]	L1 [mm]	L2 [mm]	H [mm]	H1 [mm]	H2 [mm]	H3 [mm]	SC
* 10		167 061 003	5	8	11	14	20	10	6	12	M4
* 12		167 061 004	5	8	11	14	21	10	6	12	M5
* 16		167 061 035	6	11	14	17	27	10	6	16	M5
* 20		167 061 036	6	11	17	19	27	10	6	16	M5
* 25		167 061 037	6	11	19	22	30	10	6	16	M5
* 32		167 061 038	6	11	24	27	36	10	6	16	M5
40		167 061 039	7	14	34	34	44	10	7	22	M6
50		167 061 040	7	14	37	37	51	10	7	22	M6
63		167 061 041	9	17	45	45	64	10	10	25	M8
75	2 ½	167 061 012	9	17	52	52	58	10	10	25	M8
90	3	167 061 013	9	17	65	65	65	10	10	28	M8
110	4	167 061 014	9	17	79	79	75	10	10	28	M8
125		167 061 015	9	17	88	88	90	10	10	32	M8
140	5	167 061 016	9	17	98	98	110	10	10	32	M8
160		167 061 017	9	17	109	109	108	10	10	32	M8

KLIP-IT spacer type 061 PP

Model:

- For pipe clips Type 061/061H, PP black, UV resistant
- **Minimum order quantity: standard packaging SP**

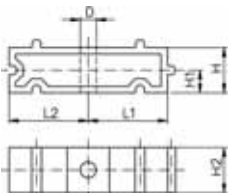

d [mm]	Inch [inch]	Code	D [mm]	L1 [mm]	L2 [mm]	H [mm]	H1 [mm]	H2 [mm]	HoH +/- 2mm [mm]	SC
10 - 12	¼ - ¼	167 061 153	5	11	14	20	10	12	1.0	M4
16	⅜	167 061 155	6	14	17	20	10	16	17.0	M5
20	½	167 061 156	6	17	19	20	10	16	21.4	M5
25	¾	167 061 157	6	19	22	20	10	16	26.9	M5
32	1	167 061 158	6	24	27	20	10	16	36.7	M5

table continued next page

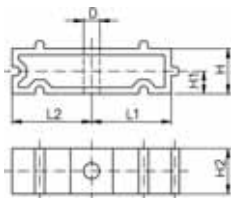

d [mm]	Inch [inch]	Code	D [mm]	L1 [mm]	L2 [mm]	H [mm]	H1 [mm]	H2 [mm]	HoH +/- 2mm [mm]	SC
40	1 1/4	167 061 159	7	34	34	20	10	22	44.4	M6
50	1 1/2	167 061 160	7	37	37	20	10	22	52.3	M6
63	2	167 061 161	9	45	45	20	10	25	66.7	M8
75	2 1/2	167 061 162	9	52	52	20	10	25	81.2	M8
90	3	167 061 163	9	65	65	20	10	28	100.0	M8
110	4	167 061 164	9	79	79	20	10	28	127.3	M8
125	4 1/2	167 061 165	9	88	88	20	10	32	142.9	M8
140	5	167 061 166	9	98	98	20	10	32	161.4	M8
160	6	167 061 167	9	109	109	20	10	32	185.1	M8

KLIP-IT pipe clip type 061 PE metric

Model:

- Material: Clip PE and safety clip PP black, bolts galvanized
- **Minimum order quantity: standard packaging SP**
- Height not designed for ball valve 546 and 543. Please use spacer 73 06 11.

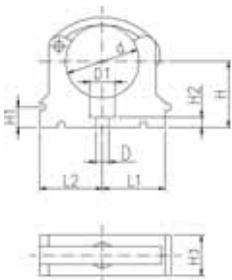

d [mm]	Code	D [mm]	D1 [mm]	L1 [mm]	L2 [mm]	H [mm]	H1 [mm]	H2 [mm]	H3 [mm]	HoH +/- 2mm [mm]	SC
* 10	173 061 003	5	8	11	14	20	10	6	12	1.0	M4
* 12	173 061 004	5	8	11	14	21	10	6	12	1.0	M5
* 16	173 061 005	6	11	14	17	23	10	6	16	17.0	M5
* 20	173 061 006	6	11	17	19	25	10	6	16	21.4	M5
* 25	173 061 007	6	11	19	22	28	10	6	16	26.9	M5
* 32	173 061 008	6	11	24	27	31	10	6	16	36.7	M5
40	173 061 009	7	14	34	34	35	10	7	22	44.4	M6
50	173 061 010	7	14	37	37	40	10	7	22	52.3	M6
63	173 061 011	9	17	45	45	52	10	10	25	66.7	M8
75	173 061 012	9	17	52	52	58	10	10	25	81.2	M8
90	173 061 013	9	17	65	65	65	10	10	28	100.0	M8
110	173 061 014	9	17	79	79	75	10	10	28	127.3	M8
125	173 061 015	9	17	88	88	90	10	10	32	142.9	M8
140	173 061 016	9	17	98	98	110	10	10	32	161.4	M8
160	173 061 017	9	17	109	109	108	10	10	32	185.1	M8

73 06 11

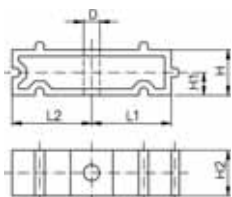

KLIP-IT spacer type 061 PE

Model:

- For pipe clips Type 061, PE black, UV resistant
- **Minimum order quantity: standard packaging SP**

d [mm]	Inch	Code	D [mm]	L1 [mm]	L2 [mm]	H [mm]	H1 [mm]	H2 [mm]	SC
16	1/8-1/4	173 061 153	5	11	14	20	10	12	M4
20	3/8	173 061 155	6	14	17	20	10	16	M5
25	1/2	173 061 156	6	17	19	20	10	16	M5
32	3/4	173 061 157	6	19	22	20	10	16	M5
40	1	173 061 158	6	24	27	20	10	16	M5
40	1 1/4	173 061 159	7	34	34	20	10	22	M6
50	1 1/2	173 061 160	7	37	37	20	10	22	M6
63	2	173 061 161	9	45	45	20	10	25	M8
75	2 1/2	173 061 162	9	52	52	20	10	25	M8
90	3	173 061 163	9	65	65	20	10	28	M8
110	4	173 061 164	9	79	79	20	10	28	M8
125	4 1/2	173 061 165	9	88	88	20	10	32	M8
140	5	173 061 166	9	98	98	20	10	32	M8
160	6	173 061 167	9	109	109	20	10	32	M8



Pipe clip type 060 PP metric

Model:

- Material: Clip and safety clip PP black, UV resistant, bolts galvanized
- Accidental opening of the safety clip is not possible
- **Minimum order quantity: standard packaging SP or gross packaging GP**
- Clip and safety clip are not assembled in the packaging.
- Pipes with flanges can be installed directly

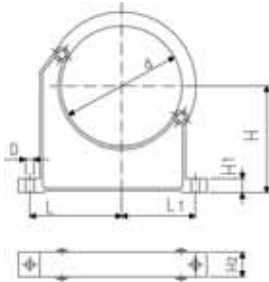

d [mm]	d [inch]	Code	D [mm]	L [mm]	L1 [mm]	H [mm]	H1 [mm]	H2 [mm]	SC
90	3	167 060 038	9	89	71	105	15	33	M 8
110		167 060 039	9	94	80	115	15	33	M 8
125		167 060 040	11	116	91	130	20	35	M10
140	5	167 060 041	11	121	98	130	20	35	M10
160		167 060 042	11	131	107	148	20	35	M10
180		167 060 043	11	143	115	163	20	35	M10
200		167 060 019	13	152	120	175	25	39	M12
225		167 060 020	13	165	132	175	25	39	M12
250		167 060 021	13	183	143	200	25	39	M12
280		167 060 022	13	198	156	200	25	39	M12
315		167 060 023	13	219	172	225	25	39	M12
355		167 060 024	17	275	209	258	30	50	M16
400		167 060 025	17	300	228	288	30	50	M16

Spare parts ball valves

Spare parts ball valve type 546



Central part

Model:

- Every connecting pieces and union nuts are listed on product range industry valves
- Ball seals standard in PTFE
- Central part consisting of: body (1), union bush (2), ball (5), stem (6), ball-, backing-, body-, face- and stem seal (7-11), standard lever (12) and threaded inserts stainless steel (14)

d [mm]	Inch	DN [mm]	PVC-U EPDM Code	PVC-U FPM Code	PVC-C EPDM Code	PVC-C FPM Code	ABS EPDM Code
16	¾	10	161 486 151	161 486 163	163 481 251	163 481 263	169 480 751
20	½	15	161 486 151	161 486 163	163 481 251	163 481 263	169 480 751
25	¾	20	161 486 152	161 486 164	163 481 252	163 481 264	169 480 752
32	1	25	161 486 153	161 486 165	163 481 253	163 481 265	169 480 753
40	1 ¼	32	161 486 154	161 486 166	163 481 254	163 481 266	169 480 754
50	1 ½	40	161 486 155	161 486 167	163 481 255	163 481 267	169 480 755
63	2	50	161 486 156	161 486 168	163 481 256	163 481 268	169 480 756
75	2 ½	65	161 486 157	161 486 169	163 481 257	163 481 269	169 480 757
90	3	80	161 486 158	161 486 170	163 481 258	163 481 270	169 480 758
110	4	100	161 486 159	161 486 171	163 481 259	163 481 271	169 480 759

d [mm]	Inch	DN [mm]	PP-H EPDM Code	PP-H FPM Code	PVDF FPM Code
16	¾	10	167 482 876	167 482 888	175 482 963
20	½	15	167 482 876	167 482 888	175 482 963
25	¾	20	167 482 877	167 482 889	175 482 964
32	1	25	167 482 878	167 482 890	175 482 965
40	1 ¼	32	167 482 879	167 482 891	175 482 966
50	1 ½	40	167 482 880	167 482 892	175 482 967
63	2	50	167 482 881	167 482 893	175 482 968
75	2 ½	65	167 482 882	167 482 894	175 482 969
90	3	80	167 482 883	167 482 895	175 482 970
110	4	100	167 482 884	167 482 896	175 482 971



Ball set

Model:

- Ball seals standard in PTFE
- Ball set consisting of: ball (5), stem (6), ball-, backing-, body- and stem seal (7-9,11)

d [mm]	Inch	DN [mm]	PVC-U EPDM Code	PVC-U FPM Code	PVC-C EPDM Code	PVC-C FPM Code	ABS EPDM Code
16	3/8	10	161 486 375	161 486 385	163 481 375	163 481 385	169 480 900
20	1/2	15	161 486 375	161 486 385	163 481 375	163 481 385	169 480 900
25	3/4	20	161 486 376	161 486 386	163 481 376	163 481 386	169 480 901
32	1	25	161 486 377	161 486 387	163 481 377	163 481 387	169 480 902
40	1 1/4	32	161 486 378	161 486 388	163 481 378	163 481 388	169 480 903
50	1 1/2	40	161 486 379	161 486 389	163 481 379	163 481 389	169 480 904
63	2	50	161 486 380	161 486 390	163 481 380	163 481 390	169 480 905
75	2 1/2	65	161 486 381	161 486 391	163 481 381	163 481 391	169 480 906
90	3	80	161 486 382	161 486 392	163 481 382	163 481 392	169 480 907
110	4	100	161 486 383	161 486 393	163 481 383	163 481 393	169 480 908

d [mm]	Inch	DN [mm]	PP-H EPDM Code	PP-H FPM Code	PVDF FPM Code
16	3/8	10	167 484 125	167 484 135	175 483 275
20	1/2	15	167 484 125	167 484 135	175 483 275
25	3/4	20	167 484 126	167 484 136	175 483 276
32	1	25	167 484 127	167 484 137	175 483 277
40	1 1/4	32	167 484 128	167 484 138	175 483 278
50	1 1/2	40	167 484 129	167 484 139	175 483 279
63	2	50	167 484 130	167 484 140	175 483 280
75	2 1/2	65	167 484 131	167 484 141	175 483 281
90	3	80	167 484 132	167 484 142	175 483 282
110	4	100	167 484 133	167 484 143	175 483 283



DN10/15 - 50



DN10/15 - 50



Lever

d [mm]	Inch	DN [mm]	Standard lever red Code	Standard lever black Code	Multifunctional lever Code
16	3/8	10	167 484 088	167 484 076	167 484 100
20	1/2	15	167 484 088	167 484 076	167 484 100
25	3/4	20	167 484 089	167 484 077	167 484 101
32	1	25	167 484 090	167 484 078	167 484 102
40	1 1/4	32	167 484 091	167 484 079	167 484 103
50	1 1/2	40	167 484 092	167 484 080	167 484 104
63	2	50	167 484 093	167 484 081	167 484 105
75	2 1/2	65	167 484 094	167 484 082	161 486 689
90	3	80	167 484 095	167 484 083	161 486 690
110	4	100	167 484 096	167 484 084	161 486 691



Face seal

Model:

- Face seal no. 10

d [mm]	Inch	DN [mm]	EPDM Code	FPM Code
16	3/8	10	748 410 059	749 410 059
20	1/2	15	748 410 059	749 410 059
25	3/4	20	748 410 106	749 410 106
32	1	25	748 410 151	749 410 151
40	1 1/4	32	748 410 062	749 410 062
50	1 1/2	40	748 410 003	749 410 003
63	2	50	748 410 231	749 410 231

table continued next page

d [mm]	Inch	DN [mm]	EPDM Code	FPM Code	
75	2 ½	65	748 410 119	749 410 119	
90	3	80	748 410 023	749 410 023	
110	4	100	748 410 254	749 410 254	



Seal set

Model:

- Seal set consisting of: backing-, body-, face- and stem seal (8-11)

d [mm]	Inch	DN [mm]	EPDM Code	FPM Code	
16	¾	10	161 486 400	161 486 410	
20	½	15	161 486 400	161 486 410	
25	¾	20	161 486 401	161 486 411	
32	1	25	161 486 402	161 486 412	
40	1 ¼	32	161 486 403	161 486 413	
50	1 ½	40	161 486 404	161 486 414	
63	2	50	161 486 405	161 486 415	
75	2 ½	65	161 486 406	161 486 416	
90	3	80	161 486 407	161 486 417	
110	4	100	161 486 408	161 486 418	

Spare parts metering ball valve type 523

Central part

Model:

- Every connecting pieces and union nuts are listed on product range industry valves
- Ball seals standard in PTFE
- Central part consisting of: body, union bush, ball, stem, ball-, backing-, body-, face- and stem seal, standard lever and threaded inserts stainless steel



d [mm]	Inch	DN [mm]	PVC-U EPDM Code	PVC-U FPM Code	PP-H EPDM Code	PP-H FPM Code	
16	¾	10	161 485 351	161 485 361	167 485 371	167 485 381	
20	½	15	161 485 353	161 485 363	167 485 373	167 485 383	

Spare parts ball valve type 543 horizontal



table continued next page



Central part L-port

Model:

- Every connecting pieces and union nuts are listed on product range industry valves
- Ball seals standard in PTFE
- Central part consisting of: body (1), union bush (2), ball (5), stem (6), ball-, backing-, body-, face- and stem seal (7-11), standard lever (12) and threaded inserts stainless steel (14)

d [mm]	Inch	DN [mm]	PVC-U EPDM Code	PVC-U FPM Code	PVC-C EPDM Code	PVC-C FPM Code	ABS EPDM Code
16	3/8	10	161 488 002	161 488 012	163 481 902	163 481 912	169 481 202
20	1/2	15	161 488 002	161 488 012	163 481 902	163 481 912	169 481 202
25	3/4	20	161 488 003	161 488 013	163 481 903	163 481 913	169 481 203
32	1	25	161 488 004	161 488 014	163 481 904	163 481 914	169 481 204
40	1 1/4	32	161 488 005	161 488 015	163 481 905	163 481 915	169 481 205
50	1 1/2	40	161 488 006	161 488 016	163 481 906	163 481 916	169 481 206
63	2	50	161 488 007	161 488 017	163 481 907	163 481 917	169 481 207

d [mm]	Inch	DN [mm]	PP-H EPDM Code	PP-H FPM Code	PVDF FPM Code
16	3/8	10	167 484 802	167 484 812	175 483 602
20	1/2	15	167 484 802	167 484 812	175 483 602
25	3/4	20	167 484 803	167 484 813	175 483 603
32	1	25	167 484 804	167 484 814	175 483 604
40	1 1/4	32	167 484 805	167 484 815	175 483 605
50	1 1/2	40	167 484 806	167 484 816	175 483 606
63	2	50	167 484 807	167 484 817	175 483 607



Central part T-port

Model:

- Ball seals standard in PTFE
- Central part consisting of: body (1), union bush (2), ball (5), stem (6), ball-, backing-, body-, face- and stem seal (7-11), standard lever (12) and threaded inserts stainless steel (14)

d [mm]	Inch	DN [mm]	PVC-U EPDM Code	PVC-U FPM Code	PVC-C EPDM Code	PVC-C FPM Code	ABS EPDM Code
16	3/8	10	161 488 022	161 488 032	163 481 922	163 481 932	169 481 212
20	1/2	15	161 488 022	161 488 032	163 481 922	163 481 932	169 481 212
25	3/4	20	161 488 023	161 488 033	163 481 923	163 481 933	169 481 213
32	1	25	161 488 024	161 488 034	163 481 924	163 481 934	169 481 214
40	1 1/4	32	161 488 025	161 488 035	163 481 925	163 481 935	169 481 215
50	1 1/2	40	161 488 026	161 488 036	163 481 926	163 481 936	169 481 216
63	2	50	161 488 027	161 488 037	163 481 927	163 481 937	169 481 217

d [mm]	Inch	DN [mm]	PP-H EPDM Code	PP-H FPM Code	PVDF FPM Code
16	3/8	10	167 484 822	167 484 832	175 483 612
20	1/2	15	167 484 822	167 484 832	175 483 612
25	3/4	20	167 484 823	167 484 833	175 483 613
32	1	25	167 484 824	167 484 834	175 483 614
40	1 1/4	32	167 484 825	167 484 835	175 483 615
50	1 1/2	40	167 484 826	167 484 836	175 483 616
63	2	50	167 484 827	167 484 837	175 483 617



Ball set L-port

Model:

- Ball seals standard in PTFE
- Ball set consisting of: lever (12), ball (5), stem (6), ball-, backing-, body- and stem seal (7-9,11)

d [mm]	Inch	DN [mm]	PVC-U EPDM Code	PVC-U FPM Code	PVC-C EPDM Code	PVC-C FPM Code	ABS EPDM Code
16	3/8	10	161 488 162	161 488 172	163 481 982	163 481 992	169 481 282
20	1/2	15	161 488 162	161 488 172	163 481 982	163 481 992	169 481 282
25	3/4	20	161 488 163	161 488 173	163 481 983	163 481 993	169 481 283
32	1	25	161 488 164	161 488 174	163 481 984	163 481 994	169 481 284
40	1 1/4	32	161 488 165	161 488 175	163 481 985	163 481 995	169 481 285
50	1 1/2	40	161 488 166	161 488 176	163 481 986	163 481 996	169 481 286
63	2	50	161 488 167	161 488 177	163 481 987	163 481 997	169 481 287

d [mm]	Inch	DN [mm]	PP-H EPDM Code	PP-H FPM Code	PVDF FPM Code
16	3/8	10	167 484 882	167 484 892	175 483 642
20	1/2	15	167 484 882	167 484 892	175 483 642
25	3/4	20	167 484 883	167 484 893	175 483 643
32	1	25	167 484 884	167 484 894	175 483 644
40	1 1/4	32	167 484 885	167 484 895	175 483 645
50	1 1/2	40	167 484 886	167 484 896	175 483 646
63	2	50	167 484 887	167 484 897	175 483 647



Ball set T-port

Model:

- Ball seals standard in PTFE
- Ball set consisting of: lever (12), ball (5), stem (6), ball-, backing-, body- and stem seal (7-9,11)

d [mm]	Inch	DN [mm]	PVC-U EPDM Code	PVC-U FPM Code	PVC-C EPDM Code	PVC-C FPM Code	ABS EPDM Code
16	3/8	10	161 488 182	161 488 192	163 482 002	163 482 012	169 481 292
20	1/2	15	161 488 182	161 488 192	163 482 002	163 482 012	169 481 292
25	3/4	20	161 488 183	161 488 193	163 482 003	163 482 013	169 481 293
32	1	25	161 488 184	161 488 194	163 482 004	163 482 014	169 481 294
40	1 1/4	32	161 488 185	161 488 195	163 482 005	163 482 015	169 481 295
50	1 1/2	40	161 488 186	161 488 196	163 482 006	163 482 016	169 481 296
63	2	50	161 488 187	161 488 197	163 482 007	163 482 017	169 481 297

d [mm]	Inch	DN [mm]	PP-H EPDM Code	PP-H FPM Code	PVDF FPM Code
16	3/8	10	167 484 902	167 484 912	175 483 652
20	1/2	15	167 484 902	167 484 912	175 483 652
25	3/4	20	167 484 903	167 484 913	175 483 653
32	1	25	167 484 904	167 484 914	175 483 654
40	1 1/4	32	167 484 905	167 484 915	175 483 655
50	1 1/2	40	167 484 906	167 484 916	175 483 656
63	2	50	167 484 907	167 484 917	175 483 657



Lever

d [mm]	Inch	DN [mm]	Standard lever L- port red Code	Standard lever L- port black Code	Standard lever T- port red Code
16	3/8	10	167 484 488	167 484 376	167 484 588
20	1/2	15	167 484 488	167 484 376	167 484 588
25	3/4	20	167 484 489	167 484 377	167 484 589
32	1	25	167 484 490	167 484 378	167 484 590
40	1 1/4	32	167 484 491	167 484 379	167 484 591
50	1 1/2	40	167 484 492	167 484 380	167 484 592
63	2	50	167 484 493	167 484 381	167 484 593

d [mm]	Inch	DN [mm]	Standard lever T- port black Code	Multifunctional- lever L-port red Code	Multifunctional- lever T-port red Code
16	3/8	10	167 484 576	167 484 442	167 484 542
20	1/2	15	167 484 576	167 484 442	167 484 542
25	3/4	20	167 484 577	167 484 443	167 484 543
32	1	25	167 484 578	167 484 444	167 484 544
40	1 1/4	32	167 484 579	167 484 445	167 484 545
50	1 1/2	40	167 484 580	167 484 446	167 484 546
63	2	50	167 484 581	167 484 447	167 484 547



Face seal

Model:

- Face seal no. 10

d [mm]	Inch	DN [mm]	EPDM Code	FPM Code
16	3/8	10	748 410 059	749 410 059
20	1/2	15	748 410 059	749 410 059
25	3/4	20	748 410 106	749 410 106
32	1	25	748 410 151	749 410 151
40	1 1/4	32	748 410 062	749 410 062
50	1 1/2	40	748 410 003	749 410 003
63	2	50	748 410 231	749 410 231



Seal set

Model:

- Seal set consisting of: backing-, body-, face- and stem seal (8-11)

d [mm]	Inch	DN [mm]	EPDM Code	FPM Code
16	3/8	10	161 488 242	161 488 248
20	1/2	15	161 488 242	161 488 248
25	3/4	20	161 488 243	161 488 249
32	1	25	161 488 244	161 488 250
40	1 1/4	32	161 488 245	161 488 251
50	1 1/2	40	161 488 246	161 488 252
63	2	50	161 488 247	161 488 253



Turn limiter 90°

d [mm]	Inch	DN [mm]	Code
16	3/8	10	167 482 479
20	1/2	15	167 482 479
25	3/4	20	167 482 480
32	1	25	167 482 480
40	1 1/4	32	167 482 481
50	1 1/2	40	167 482 481
63	2	50	167 482 482



Assembly kit

Model:

- Intermediate element for ball valve type 543 horizontal and electric or pneumatic actuators EA21; PA11/21
- Including screws and position indicator for actuators

d [mm]	Inch [inch]	DN [mm]	Code
16 - 20	3/8 - 1/2	10 - 15	167 484 941
25 - 32	3/4 - 1	20 - 25	167 484 942
40 - 50	1 1/4 - 1 1/2	32 - 40	167 484 943
63	2	50	167 484 944

Spare parts ball valve type 543 vertical

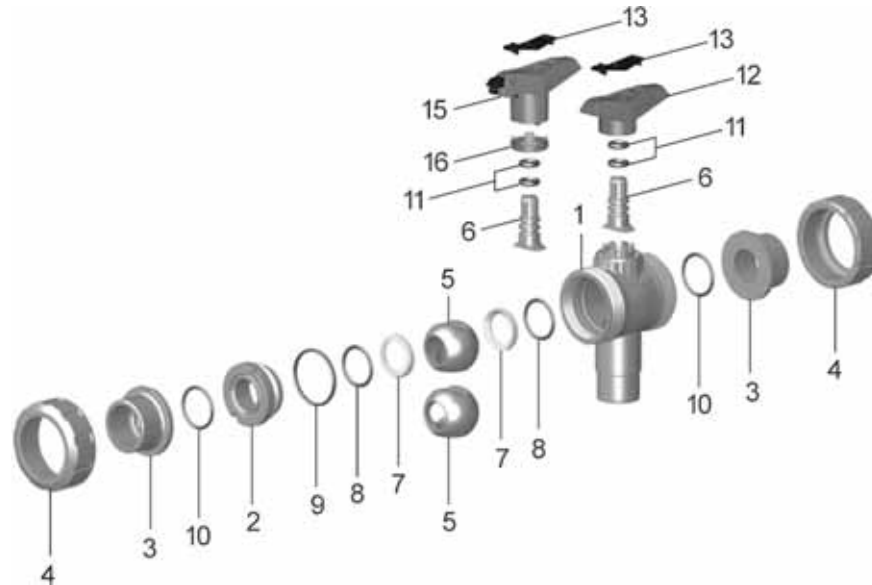

Central part L-port

Model:

- Every connecting pieces and union nuts are listed on product range industry valves
- Ball seals standard in PTFE
- Central part consisting of: body (1), union bush (2), ball (5), stem (6), ball-, backing-, body-, face- and stem seal (7-11) and standard lever (12)

d [mm]	Inch	DN [mm]	PVC-U EPDM Code	PVC-U FPM Code	ABS EPDM Code
16	3/8	10	161 488 041	161 488 051	169 481 221
20	3/8	15	161 488 042	161 488 052	169 481 222
25	3/4	20	161 488 043	161 488 053	169 481 223
32	1	25	161 488 044	161 488 054	169 481 224
40	1 1/4	32	161 488 045	161 488 055	169 481 225
50	1 1/2	40	161 488 046	161 488 056	169 481 226
63	2	50	161 488 047	161 488 057	169 481 227



Central part diverter ball

Model:

- Ball seals standard in PTFE
- Central part consisting of: body (1), union bush (2), ball (5), stem (6), ball-, backing-, body-, face- and stem seal (7-11) and standard lever (12)

d [mm]	Inch	DN [mm]	PVC-U EPDM Code	PVC-U FPM Code	ABS EPDM Code
16	3/8	10	161 488 061	161 488 071	169 481 231
20	1/2	15	161 488 062	161 488 072	169 481 232
25	3/4	20	161 488 063	161 488 073	169 481 233
32	1	25	161 488 064	161 488 074	169 481 234
40	1 1/4	32	161 488 065	161 488 075	169 481 235
50	1 1/2	40	161 488 066	161 488 076	169 481 236
63	2	50	161 488 067	161 488 077	169 481 237





Ball set L-port

Model:

- Ball seals standard in PTFE
- Ball set consisting of: lever (12), ball (5), stem (6), ball-, backing-, body- and stem seal (7-9,11)

d [mm]	Inch	DN [mm]	PVC-U EPDM Code	PVC-U FPM Code	ABS EPDM Code
16	3/8	10	161 488 202	161 488 212	169 481 302
20	1/2	15	161 488 202	161 488 212	169 481 302
25	3/4	20	161 488 203	161 488 213	169 481 303
32	1	25	161 488 204	161 488 214	169 481 304
40	1 1/4	32	161 488 205	161 488 215	169 481 305
50	1 1/2	40	161 488 206	161 488 216	169 481 306
63	2	50	161 488 207	161 488 217	169 481 307



Ball set T-Port

Model:

- Ball seals standard in PTFE
- Ball set consisting of: lever (12), ball (5), stem (6), ball-, backing-, body- and stem seal (7-9,11)

d [mm]	Inch	DN [mm]	PVC-U EPDM Code	PVC-U FPM Code	ABS EPDM Code
16	3/8	10	161 488 222	161 488 232	169 481 312
20	1/2	15	161 488 222	161 488 232	169 481 312
25	3/4	20	161 488 223	161 488 233	169 481 313
32	1	25	161 488 224	161 488 234	169 481 314
40	1 1/4	32	161 488 225	161 488 235	169 481 315
50	1 1/2	40	161 488 226	161 488 236	169 481 316
63	2	50	161 488 227	161 488 237	169 481 317



Lever

d [mm]	Inch	DN [mm]	Standard lever L-port red Code	Standard lever diverter ball red Code	Multifunctional-lever L-port red Code
16	3/8	10	167 484 688	167 484 788	167 484 642
20	1/2	15	167 484 688	167 484 788	167 484 642
25	3/4	20	167 484 689	167 484 789	167 484 643
32	1	25	167 484 690	167 484 790	167 484 644
40	1 1/4	32	167 484 691	167 484 791	167 484 645
50	1 1/2	40	167 484 692	167 484 792	167 484 646
63	2	50	167 484 693	167 484 793	167 484 647

d [mm]	Inch	DN [mm]	Multifunctional-lever diverter ball red Code
16	3/8	10	167 484 742
20	1/2	15	167 484 742
25	3/4	20	167 484 743
32	1	25	167 484 744
40	1 1/4	32	167 484 745
50	1 1/2	40	167 484 746
63	2	50	167 484 747



Face seal

Model:

- Face seal no. 10

d [mm]	Inch	DN [mm]	EPDM Code	FPM Code
16	3/8	10	748 410 059	749 410 059
20	1/2	15	748 410 059	749 410 059
25	3/4	20	748 410 106	749 410 106

table continued next page

d [mm]	Inch	DN [mm]	EPDM Code	FPM Code
32	1	25	748 410 151	749 410 151
40	1 ¼	32	748 410 062	749 410 062
50	1 ½	40	748 410 003	749 410 003
63	2	50	748 410 231	749 410 231



Seal set

Model:

- Seal set consisting of: backing-, body-, face- and stem seal (8-11)

d [mm]	Inch	DN [mm]	EPDM Code	FPM Code
16	¾	10	161 486 400	161 486 410
20	½	15	161 486 400	161 486 410
25	¾	20	161 486 401	161 486 411
32	1	25	161 486 402	161 486 412
40	1 ¼	32	161 486 403	161 486 413
50	1 ½	40	161 486 404	161 486 414
63	2	50	161 486 405	161 486 415



Assembly kit

Model:

- Intermediate element for ball valve type 543 vertical and electric or pneumatic actuators EA21; PA11/21
- Including screws and position indicator for actuators

d [mm]	Inch [inch]	DN [mm]	Code
16 - 20	¾ - ½	10 - 15	167 484 945
25 - 32	¾ - 1	20 - 25	167 484 946
40 - 50	1 ¼ - 1 ½	32 - 40	167 484 947
63	2	50	167 484 948

Spare parts ball valve type 346

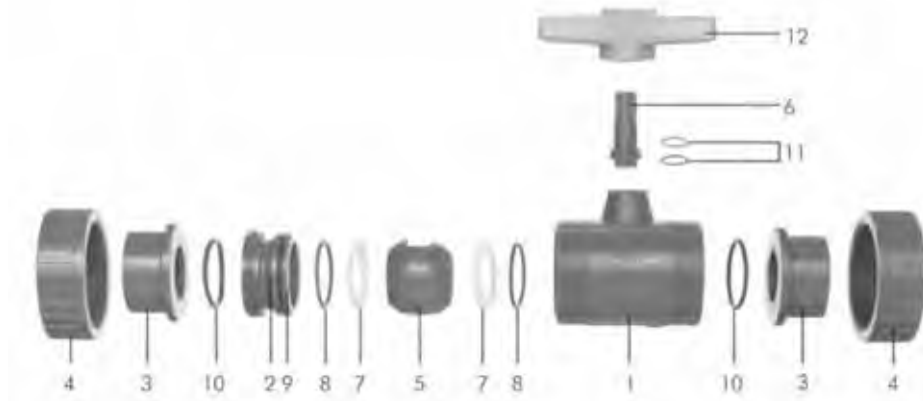

Central part

Model:

- Ball seals standard in PTFE
- Central part consisting of: lever red (12), body (1), union bush (2), ball (5), stem (6), ball-, backing-, body- and stem seal (7-9,11)



d [mm]	Inch	DN [mm]	PVC-U EPDM Code	PVC-U FPM Code	PVC-C EPDM Code	PVC-C FPM Code	ABS EPDM Code
16	¾	10	161 483 930	161 483 940	163 480 620	163 480 630	169 480 301
20	½	15	161 483 931	161 483 941	163 480 621	163 480 631	169 480 301
25	¾	20	161 483 932	161 483 942	163 480 622	163 480 632	169 480 302
32	1	25	161 483 933	161 483 943	163 480 623	163 480 633	169 480 303
40	1 ¼	32	161 483 934	161 483 944	163 480 624	163 480 634	169 480 304
50	1 ½	40	161 483 935	161 483 945	163 480 625	163 480 635	169 480 305
63	2	50	161 483 936	161 483 946	163 480 626	163 480 636	169 480 306

table continued next page

d [mm]	Inch	DN [mm]	PP-H EPDM Code	PP-H FPM Code	PVDF FPM Code
16	3/8	10	167 480 806	167 480 813	175 480 825
20	1/2	15	167 480 807	167 480 814	175 480 826
25	3/4	20	167 480 808	167 480 815	175 480 827
32	1	25	167 480 809	167 480 816	175 480 828
40	1 1/4	32	167 480 810	167 480 817	175 480 829
50	1 1/2	40	167 480 811	167 480 818	175 480 830
63	2	50	167 480 812	167 480 819	175 480 831

Ball set

Model:

- Ball seals standard in PTFE
- Ball set consisting of: ball (5), stem (6), ball- and stem seal (7,11)

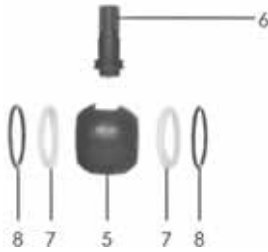

d [mm]	Inch	DN [mm]	PVC-U EPDM Code	PVC-U FPM Code	PVC-C EPDM Code	PVC-C FPM Code	ABS EPDM Code
16	3/8	10	161 482 869	161 482 875	163 480 535	163 480 545	169 480 175
20	1/2	15	161 482 869	161 482 875	163 480 535	163 480 545	169 480 175
25	3/4	20	161 482 870	161 482 876	163 480 536	163 480 546	169 480 176
32	1	25	161 482 871	161 482 877	163 480 537	163 480 547	169 480 177
40	1 1/4	32	161 482 872	161 482 878	163 480 538	163 480 548	169 480 178
50	1 1/2	40	161 482 873	161 482 879	163 480 539	163 480 549	169 480 179
63	2	50	161 482 874	161 482 880	163 480 540	163 480 550	169 480 180

d [mm]	Inch	DN [mm]	PP-H EPDM Code	PP-H FPM Code	PVDF FPM Code
16	3/8	10	167 480 875	167 480 883	175 480 900
20	1/2	15	167 480 875	167 480 883	175 480 900
25	3/4	20	167 480 876	167 480 884	175 480 901
32	1	25	167 480 877	167 480 885	175 480 902
40	1 1/4	32	167 480 878	167 480 886	175 480 903
50	1 1/2	40	167 480 879	167 480 887	175 480 904
63	2	50	167 480 880	167 480 888	175 480 905

Lever



d [mm]	Inch	DN [mm]	PVC-U orange Code	ASA black Code
16	3/8	10	161 480 725	160 480 115
20	1/2	15	161 480 725	160 480 115
25	3/4	20	161 480 726	160 480 116
32	1	25	161 480 727	160 480 117
40	1 1/4	32	161 480 728	160 480 118
50	1 1/2	40	161 480 729	160 480 119
63	2	50	161 480 730	160 480 120

Face seal

Model:

- Face seal no. 10



d [mm]	Inch	DN [mm]	EPDM Code	FPM Code
16	3/8	10	748 410 042	749 410 042
20	1/2	15	748 410 042	749 410 042
25	3/4	20	748 410 116	749 410 116
32	1	25	748 410 103	749 410 103
40	1 1/4	32	748 410 027	749 410 027
50	1 1/2	40	748 410 010	749 410 010
63	2	50	748 410 011	749 410 011



Seal set

Model:

- Seal set consisting of: backing-, body-, face- and stem seal (8-11)

d [mm]	Inch	DN [mm]	EPDM Code	FPM Code	
16	3/8	10	161 482 883	161 482 892	
20	1/2	15	161 482 883	161 482 892	
25	3/4	20	161 482 884	161 482 893	
32	1	25	161 482 885	161 482 894	
40	1 1/4	32	161 482 886	161 482 895	
50	1 1/2	40	161 482 887	161 482 896	
63	2	50	161 482 888	161 482 897	



Union nut

d [mm]	Inch	DN [mm]	PVC-U Code	PVC-C Code	ABS Code	PP-H Code	PVDF Code	
16	3/8	10	161 340 617	163 480 995	169 480 101	167 480 786	175 480 819	
20	1/2	15	161 340 617	163 480 995	169 480 101	167 480 786	175 480 819	
25	3/4	20	161 340 618	163 480 081	169 480 102	167 480 787	175 480 820	
32	1	25	161 340 619	163 480 082	169 480 103	167 480 788	175 480 821	
40	1 1/4	32	161 340 620	163 480 083	169 480 104	167 480 789	175 480 822	
50	1 1/2	40	161 340 621	163 480 084	169 480 105	167 480 790	175 480 823	
63	2	50	161 480 522	163 480 085	169 480 106	167 480 791	175 480 824	



Valve end with socket metric

d [mm]	Inch	DN [mm]	PVC-U Code	PVC-C Code	ABS Code	PP-H Code	PVDF Code	
16	3/8	10	161 480 536	163 480 522	169 480 152	167 480 159	175 480 031	
20	1/2	15	161 480 537	163 480 523	169 480 153	167 480 160	175 480 032	
25	3/4	20	161 480 538	163 480 524	169 480 154	167 480 161	175 480 033	
32	1	25	161 480 539	163 480 525	169 480 155	167 480 162	175 480 034	
40	1/4	32	161 480 540	163 480 526	169 480 156	167 480 163	175 480 035	
50	1 1/2	40	161 480 541	163 480 527	169 480 157	167 480 164	175 480 036	
63	2	50	161 480 542	163 480 528	169 480 158	167 480 165	175 480 037	

d [mm]	Inch	DN [mm]	PE80 Code	
16	3/8	10	173 480 000	
20	1/2	15	173 480 001	
25	3/4	20	173 480 002	
32	1	25	173 480 003	
40	1/4	32	173 480 004	
50	1 1/2	40	173 480 005	
63	2	50	173 480 006	



Valve end with socket ANSI/JIS/BS

Inch	DN [mm]	PVC-U ANSI Code	PVC-C ASTM Code	PP-H ANSI Code	PVC-U JIS Code	PVC-U BS Code	
3/8	10	161 482 377	163 480 172	167 480 452		161 480 543	
1/2	15	161 482 378	163 480 173	167 480 453	161 484 601	161 480 544	
3/4	20	161 482 379	163 480 174	167 480 454	161 484 602	161 480 545	
1	25	161 482 380	163 480 175	167 480 455	161 484 603	161 480 546	
1 1/4	32	161 482 381	163 480 176	167 480 456	161 484 604	161 480 547	
1 1/2	40	161 482 382	163 480 177	167 480 457	161 484 605	161 480 548	
2	50	161 482 383	163 480 178	167 480 458	161 484 606	161 480 549	

Inch	DN [mm]	ABS BS Code	
3/8	10	169 480 110	
1/2	15	169 480 111	
3/4	20	169 480 112	
1	25	169 480 113	

table continued next page

Inch	DN [mm]	ABS BS Code
1 ¼	32	169 480 114
1 ½	40	169 480 115
2	50	169 480 116

Valve end with spigot metric



d [mm]	Inch	DN [mm]	PVC-U Code	PVC-C Code	PP-H Code	PP-H SDR17,6 Code
16	¾	10	161 482 345	163 480 825	167 480 527	-
20	½	15	161 482 346	163 480 826	167 480 528	-
25	¾	20	161 482 347	163 480 827	167 480 529	-
32	1	25	161 482 348	163 480 828	167 480 530	-
40	1	32	161 482 349	163 480 829	167 480 531	-
50	1 ½	40	161 482 350	163 480 830	167 480 532	167 480 541
63	2	50	161 482 351	163 480 831	167 480 533	167 480 542

d [mm]	Inch	DN [mm]	PP-H SDR11 long Code	PP-H SDR11 IR Code	PVDF Code
16	¾	10	-	-	175 480 787
20	½	15	167 482 546	167 480 546	175 480 788
25	¾	20	167 482 547	167 480 547	175 480 789
32	1	25	167 482 548	167 480 548	175 480 790
40	1	32	167 482 549	167 480 549	175 480 791
50	1 ½	40	167 482 550	167 480 550	175 480 792
63	2	50	167 482 551	167 480 551	175 480 793

Butt fusion spigot



d [mm]	Inch	DN [mm]	PE100 SDR17,6 Code	PE100 SDR11 Code	PE100 SDR11 long Code	PVDF SDR11 IR Code
20	½	15	-	193 480 027	193 480 127	175 480 797
25	¾	20	-	193 480 028	193 480 128	175 480 798
32	1	25	-	193 480 029	193 480 129	175 480 799
40	¾	32	-	193 480 030	193 480 130	175 480 800
50	1 ½	40	193 480 017	193 480 031	193 480 131	175 480 801
63	2	50	193 480 018	193 480 032	193 480 132	175 480 802

Threaded bush Rp



Rp [inch]	DN [mm]	PVC-U Code	PVC-C Code	ABS Code	PP-H Code
¾	10	161 480 550	163 480 832	169 480 120	167 480 166
½	15	161 480 551	163 480 833	169 480 121	167 480 167
¾	20	161 480 552	163 480 834	169 480 122	167 480 168
1	25	161 480 553	163 480 835	169 480 123	167 480 169
1 ¼	32	161 480 554	163 480 836	169 480 124	167 480 170
1 ½	40	161 480 555	163 480 837	169 480 125	167 480 171
2	50	161 480 556	163 480 838	169 480 126	167 480 172

Threaded bush Rc/NPT



Inch	DN [mm]	PVC-U Rc Code	PVC-U NPT Code	PP-H NPT Code	PVDF NPT Code
¾	10		161 482 389	167 480 452	175 480 727
½	15	161 484 610	161 482 390	167 480 453	175 480 728
¾	20	161 484 611	161 482 391	167 480 454	175 480 729
1	25	161 484 612	161 482 392	167 480 455	175 480 730
1 ¼	32	161 484 613	161 482 393	167 480 456	175 480 731
1 ½	40	161 484 614	161 482 394	167 480 457	175 480 732
2	50	161 484 615	161 482 395	167 480 458	175 480 733

Fixed flange jointing face serrated metric



d [mm]	Inch	DN [mm]	PVC-U Code	PP-H Code	PVDF Code
20	¾	15	721 740 106	727 740 106	735 740 106
25	¾	20	721 740 107	727 740 107	735 740 107
32	1	25	721 740 108	727 740 108	735 740 108
40	1 ¼	32	721 740 109	727 740 109	735 740 109
50	1 ½	40	721 740 110	727 740 110	735 740 110
63	2	50	721 740 111	727 740 111	735 740 111

Spare parts ball valve type 343 horizontal

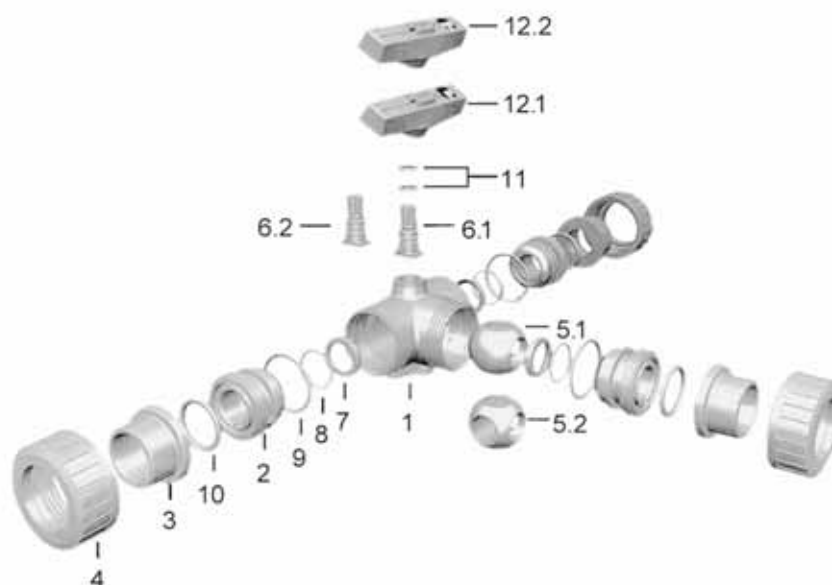

Central part L-port

Model:

- Ball seals standard in PTFE
- Central part consisting of: lever (12.1), body (1), union bush (2), ball (5.1), stem (6.1), ball-, backing-, body- and stem seal (7-9,11)

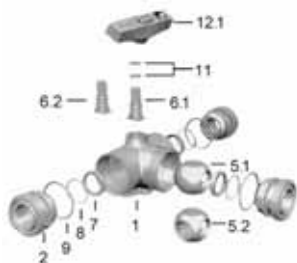

d [mm]	Inch	DN [mm]	PVC-U EPDM Code	PVC-U FPM Code	PVC-C EPDM Code	PVC-C FPM Code	ABS EPDM Code
16	¾	10	161 490 439	161 490 450	163 480 913	163 480 924	169 480 468
20	½	15	161 490 439	161 490 450	163 480 913	163 480 924	169 480 468
25	¾	20	161 490 440	161 490 451	163 480 914	163 480 925	169 480 469
32	1	25	161 490 441	161 490 452	163 480 915	163 480 926	169 480 470
40	1 ¼	32	161 490 442	161 490 453	163 480 916	163 480 927	169 480 471
50	1 ½	40	161 490 443	161 490 454	163 480 917	163 480 928	169 480 472
63	2	50	161 490 444	161 490 455	163 480 918	163 480 929	169 480 473

d [mm]	Inch	DN [mm]	PP-H EPDM Code	PP-H FPM Code	PVDF FPM Code
16	¾	10	167 482 137	167 482 148	175 482 593
20	½	15	167 482 137	167 482 148	175 482 593
25	¾	20	167 482 138	167 482 149	175 482 594
32	1	25	167 482 139	167 482 150	175 482 595
40	1 ¼	32	167 482 140	167 482 151	175 482 596
50	1 ½	40	167 482 141	167 482 152	175 482 597
63	2	50	167 482 142	167 482 153	175 482 598

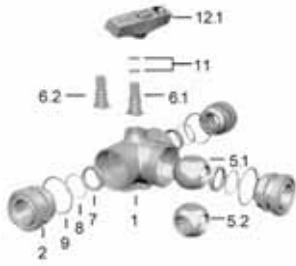

Central part T-port

Model:

- Ball seals standard in PTFE
- Central part consisting of: lever (12.1), body (1), union bush (2), ball (5.2), stem (6.2), ball-, backing-, body- and stem seal (7-9,11)

d [mm]	Inch	DN [mm]	PVC-U EPDM Code	PVC-U FPM Code	PVC-C EPDM Code	PVC-C FPM Code	ABS EPDM Code
16	3/8	10	161 490 461	161 490 472	163 480 935	163 480 946	169 480 490
20	1/2	15	161 490 461	161 490 472	163 480 935	163 480 946	169 480 490
25	3/4	20	161 490 462	161 490 473	163 480 936	163 480 947	169 480 491
32	1	25	161 490 463	161 490 474	163 480 937	163 480 948	169 480 492
40	1 1/4	32	161 490 464	161 490 475	163 480 938	163 480 949	169 480 493
50	1 1/2	40	161 490 465	161 490 476	163 480 939	163 480 950	169 480 494
63	2	50	161 490 466	161 490 477	163 480 940	163 480 951	169 480 495

d [mm]	Inch	DN [mm]	PP-H EPDM Code	PP-H FPM Code	PVDF FPM Code
16	3/8	10	167 482 159	167 482 170	175 482 620
20	1/2	15	167 482 159	167 482 170	175 482 620
25	3/4	20	167 482 160	167 482 171	175 482 621
32	1	25	167 482 161	167 482 172	175 482 622
40	1 1/4	32	167 482 162	167 482 173	175 482 623
50	1 1/2	40	167 482 163	167 482 174	175 482 624
63	2	50	167 482 164	167 482 175	175 482 625

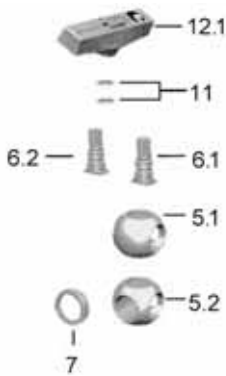

Ball set L-port

Model:

- Ball seals standard in PTFE
- Ball set consisting of: lever (12.1), ball (5.1), stem (6.1), ball- and stem seal (7,11)

d [mm]	Inch	DN [mm]	PVC-U EPDM Code	PVC-U FPM Code	PVC-C EPDM Code	PVC-C FPM Code	ABS EPDM Code
16	3/8	10	161 486 015	161 486 027	163 481 000	163 481 012	169 480 513
20	1/2	15	161 486 015	161 486 027	163 481 000	163 481 012	169 480 513
25	3/4	20	161 486 016	161 486 028	163 481 001	163 481 013	169 480 514
32	1	25	161 486 017	161 486 029	163 481 002	163 481 014	169 480 515
40	1 1/4	32	161 486 018	161 486 030	163 481 003	163 481 015	169 480 516
50	1 1/2	40	161 486 019	161 486 031	163 481 004	163 481 016	169 480 517
63	2	50	161 486 020	161 486 032	163 481 005	163 481 017	169 480 518

d [mm]	Inch	DN [mm]	PP-H EPDM Code	PP-H FPM Code	PVDF FPM Code
16	3/8	10	167 482 190	167 482 202	175 482 662
20	1/2	15	167 482 190	167 482 202	175 482 662
25	3/4	20	167 482 191	167 482 203	175 482 663
32	1	25	167 482 192	167 482 204	175 482 664
40	1 1/4	32	167 482 193	167 482 205	175 482 665
50	1 1/2	40	167 482 194	167 482 206	175 482 666
63	2	50	167 482 195	167 482 207	175 482 667

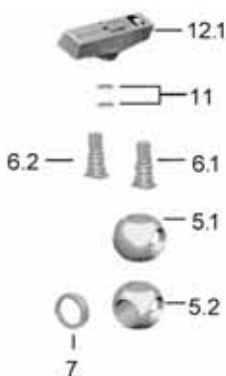

Ball set T-port

Model:

- Ball seals standard in PTFE
- Ball set consisting of: lever (12.2), ball (5.2), stem (6.2), ball- and stem seal (7,11)

d [mm]	Inch	DN [mm]	PVC-U EPDM Code	PVC-U FPM Code	PVC-C EPDM Code	PVC-C FPM Code	ABS EPDM Code
16	3/8	10	161 486 039	161 486 051	163 481 024	163 481 036	169 480 537
20	1/2	15	161 486 039	161 486 051	163 481 024	163 481 036	169 480 537
25	3/4	20	161 486 040	161 486 052	163 481 025	163 481 037	169 480 538
32	1	25	161 486 041	161 486 053	163 481 026	163 481 038	169 480 539
40	1 1/4	32	161 486 042	161 486 054	163 481 027	163 481 039	169 480 540
50	1 1/2	40	161 486 043	161 486 055	163 481 028	163 481 040	169 480 541
63	2	50	161 486 044	161 486 056	163 481 029	163 481 041	169 480 542

table continued next page

d [mm]	Inch	DN [mm]	PP-H EPDM Code	PP-H FPM Code	PVDF FPM Code
16	3/8	10	167 482 214	167 482 226	175 482 687
20	1/2	15	167 482 214	167 482 226	175 482 687
25	3/4	20	167 482 215	167 482 227	175 482 688
32	1	25	167 482 216	167 482 228	175 482 689
40	1 1/4	32	167 482 217	167 482 229	175 482 690
50	1 1/2	40	167 482 218	167 482 230	175 482 691
63	2	50	167 482 219	167 482 231	175 482 692

Lever



d [mm]	Inch	DN [mm]	L-port Code	T-port Code
16	3/8	10	161 482 151	161 486 175
20	1/2	15	161 482 151	161 486 175
25	3/4	20	161 482 152	161 486 176
32	1	25	161 482 153	161 486 177
40	1 1/4	32	161 482 154	161 486 178
50	1 1/2	40	161 482 155	161 486 179
63	2	50	161 482 156	161 486 180

Face seal



Model:

- Face seal no. 10

d [mm]	Inch	DN [mm]	EPDM Code	FPM Code
16	3/8	10	748 410 042	749 410 042
20	1/2	15	748 410 042	749 410 042
25	3/4	20	748 410 116	749 410 116
32	1	25	748 410 103	749 410 103
40	1 1/4	32	748 410 027	749 410 027
50	1 1/2	40	748 410 010	749 410 010
63	2	50	748 410 011	749 410 011

Seal set

Model:

- Seal set consisting of: backing-, body-, face- and stem seal (8-11)



d [mm]	Inch	DN [mm]	EPDM Code	FPM Code
16	3/8	10	161 484 941	161 484 951
20	1/2	15	161 484 941	161 484 951
25	3/4	20	161 484 942	161 484 952
32	1	25	161 484 943	161 484 953
40	1 1/4	32	161 484 944	161 484 954
50	1 1/2	40	161 484 945	161 484 955
63	2	50	161 484 946	161 484 956

Union nut



d [mm]	Inch	DN [mm]	PVC-U Code	PVC-C Code	ABS Code	PP-H Code	PVDF Code
16	3/8	10	161 340 617	163 480 995	169 480 101	167 480 786	175 480 819
20	1/2	15	161 340 617	163 480 995	169 480 101	167 480 786	175 480 819
25	3/4	20	161 340 618	163 480 081	169 480 102	167 480 787	175 480 820
32	1	25	161 340 619	163 480 082	169 480 103	167 480 788	175 480 821
40	1 1/4	32	161 340 620	163 480 083	169 480 104	167 480 789	175 480 822
50	1 1/2	40	161 482 119	163 480 084	169 480 105	167 480 790	175 480 823
63	2	50	161 480 522	163 480 085	169 480 106	167 480 791	175 480 824



Valve end with socket metric

d [mm]	Inch	DN [mm]	PVC-U Code	PVC-C Code	ABS Code	PP-H Code	PE80 Code
16	3/8	10	161 480 536	163 480 522	169 480 152	167 480 159	173 480 000
20	1/2	15	161 480 537	163 480 523	169 480 153	167 480 160	173 480 001
25	3/4	20	161 480 538	163 480 524	169 480 154	167 480 161	173 480 002
32	1	25	161 480 539	163 480 525	169 480 155	167 480 162	173 480 003
40	1 1/4	32	161 480 540	163 480 526	169 480 156	167 480 163	173 480 004
50	1 1/2	40	161 480 541	163 480 527	169 480 157	167 480 164	173 480 005
63	2	50	161 480 542	163 480 528	169 480 158	167 480 165	173 480 006

d [mm]	Inch	DN [mm]	PVDF Code
16	3/8	10	175 480 031
20	1/2	15	175 480 032
25	3/4	20	175 480 033
32	1	25	175 480 034
40	1 1/4	32	175 480 035
50	1 1/2	40	175 480 036
63	2	50	175 480 037



Valve end with socket ANSI/JIS/BS

Inch	DN [mm]	PVC-U ANSI Code	PP-H ANSI Code	PVC-U JIS Code	PVC-U BS Code	ABS BS Code
3/8	10	161 482 377	167 480 452		161 480 543	169 480 110
1/2	15	161 482 378	167 480 453	161 484 601	161 480 544	169 480 111
3/4	20	161 482 379	167 480 454	161 484 602	161 480 545	169 480 112
1	25	161 482 380	167 480 455	161 484 603	161 480 546	169 480 113
1 1/4	32	161 482 381	167 480 456	161 484 604	161 480 547	169 480 114
1 1/2	40	161 482 382	167 480 457	161 484 605	161 480 548	169 480 115
2	50	161 482 383	167 480 458	161 484 606	161 480 549	169 480 116



Valve end with spigot metric

d [mm]	Inch	DN [mm]	PVC-U Code	PVC-C Code	PP-H Code	PP-H SDR17,6 Code
16	3/8	10	161 482 345	163 480 825	167 480 527	-
20	1/2	15	161 482 346	163 480 826	167 480 528	-
25	3/4	20	161 482 347	163 480 827	167 480 529	-
32	1	25	161 482 348	163 480 828	167 480 530	-
40	1 1/4	32	161 482 349	163 480 829	167 480 531	-
50	1 1/2	40	161 482 350	163 480 830	167 480 532	167 480 541
63	2	50	161 482 351	163 480 831	167 480 533	167 480 542

d [mm]	Inch	DN [mm]	PP-H SDR11 long Code	PP-H SDR11 IR Code	PVDF Code
16	3/8	10	-	-	175 480 787
20	1/2	15	167 482 546	167 480 546	175 480 788
25	3/4	20	167 482 547	167 480 547	175 480 789
32	1	25	167 482 548	167 480 548	175 480 790
40	1 1/4	32	167 482 549	167 480 549	175 480 791
50	1 1/2	40	167 482 550	167 480 550	175 480 792
63	2	50	167 482 551	167 480 551	175 480 793



Butt fusion spigot

d [mm]	Inch	DN [mm]	PE100 SDR17,6 Code	PE100 SDR11 Code	PE100 SDR11 long Code	PVDF SDR11 IR Code
20	1/2	15	-	193 480 027	193 480 027	175 480 797
25	3/4	20	-	193 480 028	193 480 028	175 480 798
32	1	25	-	193 480 029	193 480 029	175 480 799

table continued next page

d [mm]	Inch	DN [mm]	PE100 SDR17,6 Code	PE100 SDR11 Code	PE100 SDR11 long Code	PVDF SDR11 IR Code
40	1 ¼	32	-	193 480 030	193 480 030	175 480 800
50	1 ½	40	193 480 017	193 480 031	193 480 031	175 480 801
63	2	50	193 480 018	193 480 032	193 480 032	175 480 802

Threaded bush Rp



Rp [inch]	DN [mm]	PVC-U Code	PVC-C Code	ABS Code	PP-H Code
¾	10	161 480 550	163 480 832	169 480 120	167 480 166
½	15	161 480 551	163 480 833	169 480 121	167 480 167
¾	20	161 480 552	163 480 834	169 480 122	167 480 168
1	25	161 480 553	163 480 835	169 480 123	167 480 169
1 ¼	32	161 480 554	163 480 836	169 480 124	167 480 170
1 ½	40	161 480 555	163 480 837	169 480 125	167 480 171
2	50	161 480 556	163 480 838	169 480 126	167 480 172

Fixed flange jointing face serrated metric



d [mm]	Inch	DN [mm]	PVC-U Code	PVC-C Code	PVDF Code
20	¾	15	721 740 106	727 740 106	735 740 106
25	¾	20	721 740 107	727 740 107	735 740 107
32	1	25	721 740 108	727 740 108	735 740 108
40	1 ¼	32	721 740 109	727 740 109	735 740 109
50	1 ½	40	721 740 110	727 740 110	735 740 110
63	2	50	721 740 111	727 740 111	735 740 111

Threaded bush Rc/NPT



Inch	DN [mm]	PVC-U Rc Code	PVC-U NPT Code	PP-H NPT Code	PVDF NPT Code
¾	10		161 482 389	167 480 452	175 480 727
½	15	161 484 610	161 482 390	167 480 453	175 480 728
¾	20	161 484 611	161 482 391	167 480 454	175 480 729
1	25	161 484 612	161 482 392	167 480 455	175 480 730
1 ¼	32	161 484 613	161 482 393	167 480 456	175 480 731
1 ½	40	161 484 614	161 482 394	167 480 457	175 480 732
2	50	161 484 615	161 482 395	167 480 458	175 480 733

Spare parts ball valve type 343 vertical

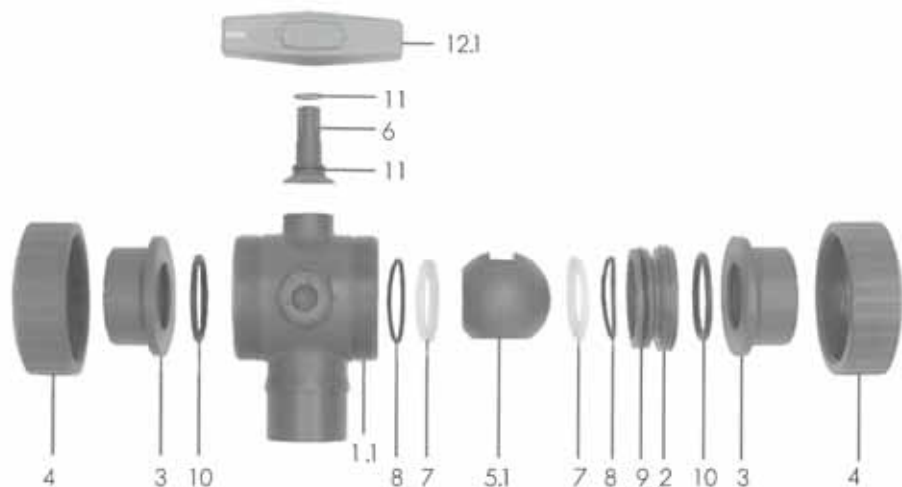

table continued next page



Central part

Model:

- Ball seals standard in PTFE
- Central part consisting of: lever (12.1), body (1.1), union bush (2), ball (5.1), stem (6), ball-, backing-, body- and stem seal (7-9,11)

d [mm]	Inch	DN [mm]	PVC-U EPDM Code	PVC-U FPM Code
16	3/8	10	161 484 230	161 484 240
20	1/2	15	161 484 231	161 484 241
25	3/4	20	161 484 232	161 484 242
32	1	25	161 484 233	161 484 243
40	1 1/4	32	161 484 234	161 484 244
50	1 1/2	40	161 484 235	161 484 245
63	2	50	161 484 236	161 484 246



Ball set L-port

Model:

- Ball seals standard in PTFE
- Ball set consisting of: lever (12.1), ball (5.1), stem (6), ball- and stem seal (7,11)

d [mm]	Inch	DN [mm]	PVC-U EPDM Code	PVC-U FPM Code
16	3/8	10	161 483 343	161 483 351
20	1/2	15	161 483 343	161 483 351
25	3/4	20	161 483 344	161 483 352
32	1	25	161 483 345	161 483 353
40	1 1/4	32	161 483 346	161 483 354
50	1 1/2	40	161 483 347	161 483 355
63	2	50	161 483 348	161 483 356



Lever

d [mm]	Inch	DN [mm]	vertical Code
16	3/8	10	161 480 715
20	1/2	15	161 480 715
25	3/4	20	161 480 716
32	1	25	161 480 717
40	1 1/4	32	161 480 718
50	1 1/2	40	161 482 146
63	2	50	161 482 147



Face seal

Model:

- Face seal no. 10

d [mm]	Inch	DN [mm]	EPDM Code	FPM Code
16	3/8	10	748 410 042	749 410 042
20	1/2	15	748 410 042	749 410 042
25	3/4	20	748 410 116	749 410 116
32	1	25	748 410 103	749 410 103
40	1 1/4	32	748 410 027	749 410 027
50	1 1/2	40	748 410 010	749 410 010
63	2	50	748 410 011	749 410 011

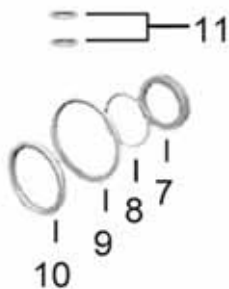

Seal set

Model:

- Seal set consisting of: backing-, body-, face- and stem seal (8-11)

d [mm]	Inch	DN [mm]	EPDM Code	FPM Code
16	¾	10	161 482 883	161 482 892
20	½	15	161 482 883	161 482 892
25	¾	20	161 482 884	161 482 893
32	1	25	161 482 885	161 482 894
40	1 ¼	32	161 482 886	161 482 895
50	1 ½	40	161 482 887	161 482 896
63	2	50	161 482 888	161 482 897



Union nut

d-d [mm]	Inch [inch]	DN-DN [mm]	PVC-U Code
16 - 20	¾ - ½	10 - 15	161 340 617
- 25	¾	- 20	161 340 618
- 32	1	- 25	161 340 619
- 40	1 ¼	- 32	161 340 620
- 50	1 ½	- 40	161 482 119
- 63		- 50	161 482 613



Valve end with socket metric

d [mm]	Inch	DN [mm]	PVC-U Code	PE80 Code
16	¾	10	161 480 536	173 480 000
20	½	15	161 480 537	173 480 001
25	¾	20	161 480 538	173 480 002
32	1	25	161 480 539	173 480 003
40	1 ¼	32	161 480 540	173 480 004
50	1 ½	40	161 480 541	173 480 005
63	2	50	161 480 542	173 480 006



Valve end with socket ANSI/JIS

Inch	DN [mm]	PVC-U JIS Code	PVC-U ANSI Code
¾	10		161 482 377
½	15	161 484 601	161 482 378
¾	20	161 484 602	161 482 379
1	25	161 484 603	161 482 380
1 ¼	32	161 484 604	161 482 381
1 ½	40	161 484 605	161 482 382
2	50	161 484 606	161 482 383



Valve end with spigot metric

d [mm]	Inch	DN [mm]	PVC-U Code
16	¾	10	161 482 345
20	½	15	161 482 346
25	¾	20	161 482 347
32	1	25	161 482 348
40	1 ¼	32	161 482 349
50	1 ½	40	161 482 350
63	2	50	161 482 351



Butt fusion spigot

d [mm]	Inch	DN [mm]	PE100 SDR11 long Code
20	¾	15	193 480 127
25	¾	20	193 480 128
32	1	25	193 480 129
40	1 ¼	32	193 480 130
50	1 ½	40	193 480 131
63	2	50	193 480 132



Threaded bush Rp

Rp [inch]	DN [mm]	PVC-U Code	PVC-C Code	ABS Code	PP-H Code
¾	10	161 480 550	163 480 832	169 480 120	167 480 166
½	15	161 480 551	163 480 833	169 480 121	167 480 167
¾	20	161 480 552	163 480 834	169 480 122	167 480 168
1	25	161 480 553	163 480 835	169 480 123	167 480 169
1 ¼	32	161 480 554	163 480 836	169 480 124	167 480 170
1 ½	40	161 480 555	163 480 837	169 480 125	167 480 171
2	50	161 480 556	163 480 838	169 480 126	167 480 172



Threaded bush Rc/NPT

Inch	DN [mm]	PVC-U Rc Code	PVC-U NPT Code	PP-H NPT Code	PVDF NPT Code
¾	10		161 482 389	167 480 452	175 480 727
½	15	161 484 610	161 482 390	167 480 453	175 480 728
¾	20	161 484 611	161 482 391	167 480 454	175 480 729
1	25	161 484 612	161 482 392	167 480 455	175 480 730
1 ¼	32	161 484 613	161 482 393	167 480 456	175 480 731
1 ½	40	161 484 614	161 482 394	167 480 457	175 480 732
2	50	161 484 615	161 482 395	167 480 458	175 480 733

Spare parts ball valve type 370

Central part radial

Model:

- Ball seals standard in PTFE
- Central part consisting of: half body, ball (1), bush (6+7), lever (8), ball-, backing-, body-, and stem seal (2-5)

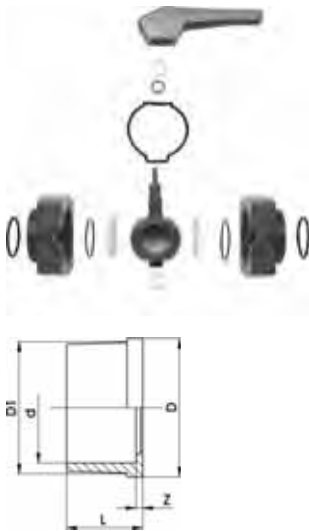

d [mm]	Inch	DN [mm]	PVC-U EPDM Code	PVC-U FPM Code	PVC-C EPDM Code	PVC-C FPM Code	ABS EPDM Code
75	2 ½	65	161 484 561	161 484 564	163 481 211	163 481 235	169 480 342
90	3	80	161 484 562	161 484 565	163 481 212	163 481 236	169 480 343
110	4	100	161 484 563	161 484 566	163 481 213	163 481 237	169 480 344



Ball set

Model:

- Ball seals standard in PTFE
- Ball set consisting of: ball (1), ball- and stem seal (2,5)

d [mm]	Inch	DN [mm]	PVC-U EPDM Code	PVC-U FPM Code	PVC-C EPDM Code	PVC-C FPM Code	ABS EPDM Code
75	2 ½	65	161 482 958	161 482 963	163 480 798	163 480 803	169 480 376
90	3	80	161 482 959	161 482 964	163 480 799	163 480 804	169 480 377
110	4	100	161 482 960	161 482 965	163 480 800	163 480 805	169 480 378
160	6	150	161 482 960	161 482 965			

d [mm]	Inch	DN [mm]	PP-H EPDM Code	PP-H FPM Code
75	2 ½	65	167 480 891	167 480 896
90	3	80	167 480 892	167 480 897
110	4	100	167 480 893	167 480 898
160	6	150	167 480 893	167 480 898



Lever

d-d [mm]	Inch [inch]	DN-DN [mm]	PVC-U orange Code	PVC-U black Code
- 75	2 ½	- 65	161 480 763	161 481 260
- 90	3	- 80	161 480 764	161 481 261
110 - 160	4 - 6	100 - 150	161 480 420	161 481 262



Face seal

Model:

- Face seal no. 9

d [mm]	Inch	DN [mm]	EPDM Code	FPM Code
75	2 ½	65	748 410 119	749 410 119
90	3	80	748 410 112	749 410 112
110	4	100	748 410 099	749 410 099



Seal set

Model:

- Seal set consisting of: backing-, body- and stem seal (3-5)

d-d [mm]	Inch [inch]	DN-DN [mm]	EPDM Code	FPM Code	
- 75	2 ½	- 65	161 482 968	161 482 974	
- 90	3	- 80	161 482 969	161 482 975	
110 - 160	4 - 6	100 - 150	161 482 970	161 482 976	



Union nut

d [mm]	Inch	DN [mm]	PVC-U Code	PVC-C Code	ABS Code	
75	2 ½	65	721 690 012	723 690 012	729 690 012	
90	3	80	721 690 013	723 690 013	729 690 013	
110	4	100	721 690 014	723 690 014	729 690 014	



Valve end with socket

d [mm]	Inch	DN [mm]	PVC-U metric Code	PVC-U blank Code	PVC-U JIS Code	PVC-U ASTM Code	
75	2 ½	65	721 600 162	721 600 012	721 605 112	721 602 005	
90	3	80	721 600 163	721 600 013	721 605 113	721 602 006	
110	4	100	721 600 164	721 600 014	721 605 114	721 602 007	

d [mm]	Inch	DN [mm]	PVC-C metric Code	ABS metric Code	
75	2 ½	65	723 600 162	729 800 162	
90	3	80	723 600 163	729 800 163	
110	4	100	723 600 164	729 800 164	

Spare parts metering ball valve type 323

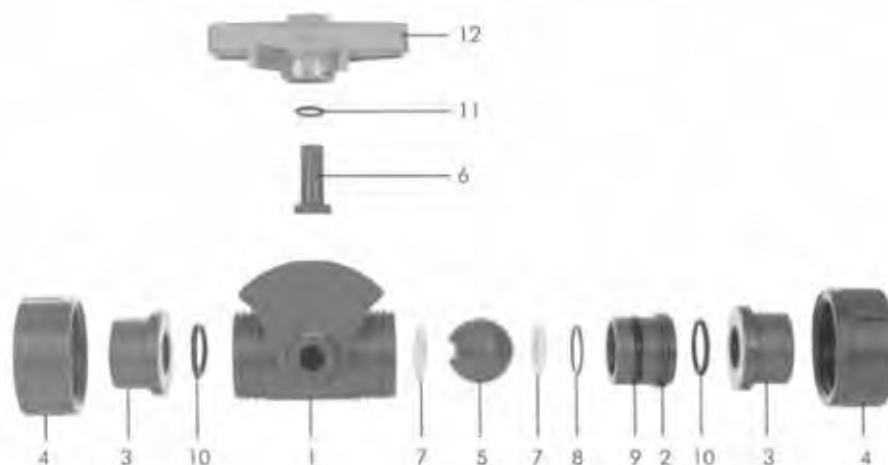

Ball set

Model:

- Ball seals standard in PTFE
- Ball set consisting of: union nut (4), ball (5), stem (6), ball- and stem seal (7,11)

d [mm]	Inch	DN [mm]	PVC-U EPDM Code	PVC-U FPM Code	PP-H EPDM Code	PP-H FPM Code
16	3/8	10	161 482 986	161 482 989	167 480 901	167 480 904
20	1/2	15	161 482 987	161 482 990	167 480 902	167 480 905



Lever

d [mm]	Inch	DN [mm]	PVC-U orange Code	ASA black Code
16	3/8	10	161 480 724	160 480 130
20	1/2	15	161 480 724	160 480 130



Face seal

Model:

- Face seal no. 10

d [mm]	Inch	DN [mm]	EPDM Code	FPM Code
16	3/8	10	748 410 042	749 410 042
20	1/2	15	748 410 042	749 410 042



Seal set

Model:

- Seal set consisting of: backing-, body-, face- and stem seal (8-11)

d [mm]	Inch	DN [mm]	EPDM Code	FPM Code
16	3/8	10	161 482 883	161 482 892
20	1/2	15	161 482 883	161 482 892



Union bush

d [mm]	Inch	DN [mm]	PVC-U Code	PP-H Code
16	3/8	10	161 482 339	167 480 519
20	1/2	15	161 482 339	167 480 519





Union nut

d [mm]	Inch	DN [mm]	PVC-U Code	PP-H Code
16	3/8	10	161 340 617	167 480 786
20	1/2	15	161 340 617	167 480 786



Valve end with socket metric

d [mm]	Inch	DN [mm]	PVC-U Code	PE80 Code	PP-H Code
16	3/8	10	161 480 536	173 480 000	167 480 159
20	1/2	15	161 480 537	173 480 001	167 480 160



Valve end with socket ANSI/JIS/BS

Inch	DN [mm]	PVC-U ANSI Code	PVC-U JIS Code	PVC-U BS Code
3/8	10	161 482 377		161 480 543
1/2	15	161 482 378	161 484 601	161 480 544



Valve end with spigot metric

d [mm]	Inch	DN [mm]	PVC-U Code	PP-H Code
16	3/8	10	161 482 345	167 480 527
20	1/2	15	161 482 346	167 480 528



Butt fusion spigot

d [mm]	Inch	DN [mm]	PE100 SDR11 long Code	PE100 SDR11 Code	PP-H SDR11 long Code	PP-H SDR11 IR Code
20	1/2	15	193 480 127	193 480 027	167 482 546	167 480 546
20	1/2	15		167 480 546		



Threaded bush Rp

Rp [inch]	DN [mm]	PVC-U Code	PVC-C Code	ABS Code	PP-H Code
3/8	10	161 480 550	163 480 832	169 480 120	167 480 166
1/2	15	161 480 551	163 480 833	169 480 121	167 480 167



Threaded bush Rc/NPT

Inch	DN [mm]	PVC-U Rc Code	PVC-U NPT Code	PVDF NPT Code
3/8	10		161 482 389	175 480 727
1/2	15	161 484 610	161 482 390	175 480 728

Spare parts ball valve type 353

Lever PP



Inch	DN [mm]	red Code	green Code	yellow Code	black Code	white Code	
½	15	167 481 160	167 481 145	167 481 155	167 481 150	167 481 570	
¾	20	167 481 161	167 481 146	167 481 156	167 481 151	167 481 571	
1	25	167 481 161	167 481 146	167 481 156	167 481 151	167 481 571	
1 ¼	32	167 481 162	167 481 147	167 481 157	167 481 152	167 481 572	
1 ½	40	167 481 162	167 481 147	167 481 157	167 481 152	167 481 572	
2	50	167 481 163	167 481 148	167 481 158	167 481 153	167 481 573	

Inch	DN [mm]	blue Code	
½	15	167 481 090	
¾	20	167 481 091	
1	25	167 481 091	
1 ¼	32	167 481 092	
1 ½	40	167 481 092	
2	50	167 481 093	

Spare parts ball valve type 354

Lever PP



d [mm]	Inch	DN [mm]	red Code	green Code	yellow Code	black Code	white Code	
20	½	15	167 481 160	161 481 145	167 481 155	167 481 150	1674781570	
25	¾	20	167 481 161	161 481 146	167 481 156	167 481 151	1674781571	
32	1	25	167 481 161	161 481 146	167 481 156	167 481 151	1674781571	
40	1 ¼	32	167 481 162	161 481 147	167 481 157	167 481 152	1674781572	
50	1 ½	40	167 481 162	161 481 147	167 481 157	167 481 152	1674781572	
63	2	50	167 481 163	161 481 148	167 481 158	167 481 153	1674781573	

d [mm]	Inch	DN [mm]	blue Code	
20	½	15	167 481 090	
25	¾	20	167 481 091	
32	1	25	167 481 091	
40	1 ¼	32	167 481 092	
50	1 ½	40	167 481 092	
63	2	50	167 481 093	



Face seal

d [mm]	Inch	DN [mm]	EPDM Code	
20	½	15	748 410 042	
25	¾	20	748 410 116	
32	1	25	748 410 103	
40	1 ¼	32	748 410 027	
50	1 ½	40	748 410 010	
63	2	50	748 410 011	



Union nut

d [mm]	Inch	DN [mm]	PVC-U Code	
20	½	15	721 690 006	
25	¾	20	721 690 007	
32	1	25	721 690 008	
40	1 ¼	32	721 690 009	
50	1 ½	40	721 690 010	
63	2	50	721 690 011	



Valve end

d [mm]	Inch	DN [mm]	PVC-U socket metric Code	PVC-U Rp Code	PVC-U NPT Code	PVC-U blank Code
20	½	15	721 600 106	721 600 656	721 602 656	721 600 006
25	¾	20	721 600 107	721 600 657	721 602 657	721 600 007
32	1	25	721 600 108	721 600 658	721 602 658	721 600 008
40	1 ¼	32	721 600 109	721 600 659	721 602 659	721 600 009
50	1 ½	40	721 600 110	721 600 660	721 602 660	721 600 010
63	2	50	721 600 111	721 600 661	721 602 661	721 600 011

Spare parts ball valve type 355

Central part

d [mm]	Inch	DN [mm]	EPDM Code
20	½	15	161 483 837
25	¾	20	161 483 838
32	1	25	161 483 839
40	1 ¼	32	161 483 840
50	1 ½	40	161 483 841
63	2	50	161 483 842



Lever PP

d [mm]	Inch	DN [mm]	red Code	green Code	yellow Code	black Code	white Code
20	½	15	167 481 160	167 481 145	167 481 155	167 481 150	167 481 570
25	¾	20	167 481 161	167 481 146	167 481 156	167 481 151	167 481 571
32	1	25	167 481 161	167 481 146	167 481 156	167 481 151	167 481 571
40	1 ¼	32	167 481 162	167 481 147	167 481 157	167 481 152	167 481 572
50	1 ½	40	167 481 162	167 481 147	167 481 157	167 481 152	167 481 572
63	2	50	167 481 163	167 481 148	167 481 158	167 481 153	167 481 573

d [mm]	Inch	DN [mm]	blue Code
20	½	15	167 481 090
25	¾	20	167 481 091
32	1	25	167 481 091
40	1 ¼	32	167 481 092
50	1 ½	40	167 481 092
63	2	50	167 481 093



Face seal

d [mm]	Inch	DN [mm]	EPDM Code
20	½	15	748 410 042
25	¾	20	748 410 116
32	1	25	748 410 103
40	1 ¼	32	748 410 027
50	1 ½	40	748 410 010
63	2	50	748 410 011



Union nut

d [mm]	Inch	DN [mm]	PVC-U Code
20	½	15	721 690 006
25	¾	20	721 690 007
32	1	25	721 690 008
40	1 ¼	32	721 690 009
50	1 ½	40	721 690 010
63	2	50	721 690 011

Valve end

d [mm]	Inch	DN [mm]	PVC-U socket metric Code	PVC-U Rp Code	PVC-U Rc Code	PVC-U NPT Code
20	½	15	721 600 106	721 600 656	721 605 606	721 602 656
25	¾	20	721 600 107	721 600 657	721 605 607	721 602 657
32	1	25	721 600 108	721 600 658	721 605 608	721 602 658
40	1 ¼	32	721 600 109	721 600 659	721 605 609	721 602 659
50	1 ½	40	721 600 110	721 600 660	721 605 610	721 602 660
63	2	50	721 600 111	721 600 661	721 605 611	721 602 661

d [mm]	Inch	DN [mm]	PVC-U socket JIS Code	PVC-U socket BS Code	PVC-U blank Code	PE socket metric Code
20	½	15	721 605 106	721 601 106	721 600 006	734 600 106
25	¾	20	721 605 107	721 601 107	721 600 007	734 600 107
32	1	25	721 605 108	721 601 108	721 600 008	734 600 108
40	1 ¼	32	721 605 109	721 601 109	721 600 009	734 600 109
50	1 ½	40	721 605 110	721 601 110	721 600 010	734 600 110
63	2	50	721 605 111	721 601 111	721 600 011	734 600 111

Spare parts butterfly valves

Spare parts butterfly valve type 567/568

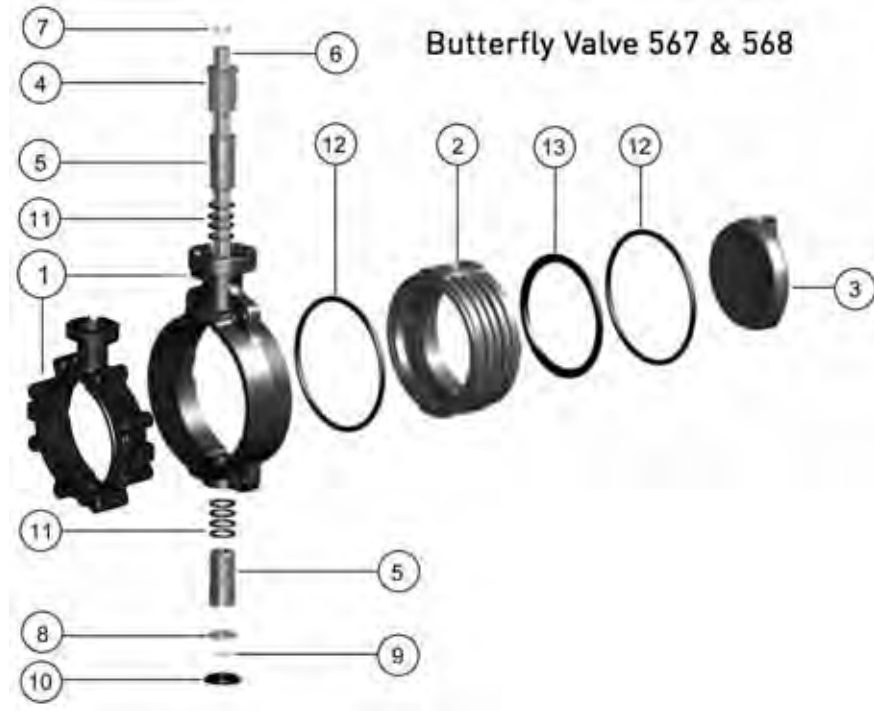

Inner body

Model:

- Inner body consisting of: inner body (2) and profile seal (13)



d [mm]	Inch	DN [mm]	PVC-U EPDM Code	PVC-U FPM Code	PVC-C EPDM Code	PVC-C FPM Code	ABS EPDM Code
63	2	50	161 486 861	161 486 873	163 481 591	163 481 603	169 481 067
75	2 ½	65	161 486 862	161 486 874	163 481 592	163 481 604	169 481 068
90	3	80	161 486 863	161 486 875	163 481 593	163 481 605	169 481 069
110	4	100	161 486 864	161 486 876	163 481 594	163 481 606	169 481 070
140	5	125	161 486 865	161 486 877	163 481 595	163 481 607	169 481 071
160	6	150	161 486 866	161 486 878	163 481 596	163 481 608	169 481 072
225	8	200	161 486 867	161 486 879	163 481 597	163 481 609	169 481 073
280	10	250	161 486 868	161 486 880			
315	12	300	161 486 869	161 486 881			

d [mm]	Inch	DN [mm]	PP-H EPDM Code	PP-H FPM Code	PVDF FPM Code	PVDF PTFE Code
63	2	50	167 484 271	167 484 286	175 483 413	175 483 752
75	2 ½	65	167 484 272	167 484 287	175 483 414	175 483 753
90	3	80	167 484 273	167 484 288	175 483 415	175 483 754
110	4	100	167 484 274	167 484 289	175 483 416	175 483 755
140	5	125	167 484 275	167 484 290	175 483 417	175 483 756
160	6	150	167 484 276	167 484 291	175 483 418	175 483 757
225	8	200	167 484 277	167 484 292	175 483 419	175 483 758
280	10	250	167 484 278	167 484 293	175 483 420	175 483 759
315	12	300	167 484 279	167 484 294	175 483 421	175 483 760



Flange seal (12)

Model:

- included in delivery 1 pcs.

d [mm]	Inch	DN [mm]	EPDM Code	FPM Code
63	2	50	161 486 959	161 486 979
75	2 ½	65	161 486 960	161 486 980
90	3	80	161 486 961	161 486 981
110	4	100	161 486 962	161 486 982
125	5	125	161 486 963	161 486 983
160	6	150	161 486 964	161 486 984
225	8	200	161 486 965	161 486 985
280	10	250	161 486 966	161 486 986
315	12	300	161 486 967	161 486 987
355	14	350	748 410 318	749 410 318
400	16	400	748 410 319	749 410 319
450	18	450	748 410 320	749 410 320
500	20	500	748 410 321	749 410 321
630	24	600	748 410 322	749 410 322



Disc (3)

d [mm]	Inch	DN [mm]	PVC-U Code	PVC-C Code	ABS Code	PP-H Code	PVDF Code
63	2	50	161 490 889	163 481 451	169 480 951	167 483 226	175 483 251
75	2 ½	65	161 490 890	163 481 452	169 480 952	167 483 227	175 483 252
90	3	80	161 490 891	163 481 453	169 480 953	167 483 228	175 483 253
110	4	100	161 490 892	163 481 454	169 480 954	167 483 229	175 483 254
140	5	125	161 490 893	163 481 455	169 480 955	167 483 230	175 483 255
160	6	150	161 490 894	163 481 456	169 480 956	167 483 231	175 483 256
225	8	200	161 490 895	163 481 457	169 480 957	167 483 232	175 483 257
280	10	250	161 490 896			167 483 233	175 483 258
315	12	300	161 490 897			167 483 234	175 483 259
355	14	350	-			167 483 235	
400	16	400	-			167 483 236	
450	18	450	-			167 483 237	
500	20	500	-			167 483 238	
630	24	600	-			167 483 239	



Bearing bush (5, 11)

Model:

- included in delivery 2 pcs.
- With O-ring
- Bearing bushes in PP-H are used in PP-H and ABS butterfly valves

d [mm]	Inch	DN [mm]	PVC-U EPDM Code	PVC-U FPM Code	PVC-C EPDM Code	PVC-C FPM Code	PP-H EPDM Code
63	2	50	161 486 886	161 486 892	163 481 576	163 481 582	167 484 259
75	2 ½	65	161 486 886	161 486 892	163 481 576	163 481 582	167 484 259
90	3	80	161 486 886	161 486 892	163 481 576	163 481 582	167 484 259
110	4	100	161 486 887	161 486 893	163 481 577	163 481 583	167 484 260
140	5	125	161 486 887	161 486 893	163 481 577	163 481 583	167 484 260
160	6	150	161 486 888	161 486 894	163 481 578	163 481 584	167 484 261
225	8	200	161 486 888	161 486 894	163 481 578	163 481 584	167 484 261
280	10	250	161 486 889	161 486 895			167 484 262
315	12	300	161 486 889	161 486 895			167 484 262
355	14	350					167 484 263
400	16	400					167 484 264
450	18	450					167 484 280
500	20	500					167 484 281
630	24	600					167 484 282

table continued next page

d [mm]	Inch	DN [mm]	PP-H FPM Code	PVDF FPM Code
63	2	50	167 484 265	175 483 426
75	2 ½	65	167 484 265	175 483 426
90	3	80	167 484 265	175 483 426
110	4	100	167 484 266	175 483 427
140	5	125	167 484 266	175 483 427
160	6	150	167 484 267	175 483 428
225	8	200	167 484 267	175 483 428
280	10	250	167 484 268	175 483 429
315	12	300	167 484 268	175 483 429
355	14	350	167 484 269	
400	16	400	167 484 270	
450	18	450	167 484 283	
500	20	500	167 484 284	
630	24	600	167 484 285	



End stop PP glasfiber reinforced (4)

d [mm]	Inch	DN [mm]	Code
63	2	50	167 483 251
75	2 ½	65	167 483 251
90	3	80	167 483 251
110	4	100	167 483 252
140	5	125	167 483 252
160	6	150	167 483 253
225	8	200	167 483 253
280	10	250	167 483 254
315	12	300	167 483 254



Shaft set

Model:

- Shaft set consisting of: shaft chrom steel 1.4301 AISI 304 (6), retention ring (7, 9) and washer (8)

d [mm]	Inch	DN [mm]	Code
63	2	50	161 486 899
75	2 ½	65	161 486 900
90	3	80	161 486 901
110	4	100	161 486 902
140	5	125	161 486 903
160	6	150	161 486 904
225	8	200	161 486 905
280	10	250	161 486 906
315	12	300	161 486 907
355	14	350	161 486 908
400	16	400	161 486 909
450	18	450	161 486 926
500	20	500	161 486 927
630	24	600	161 486 928



Hand lever

d [mm]	Inch	DN [mm]	with index plate Code	with fine adjust- ment Code
63	2	50	161 486 690	161 486 325
75	2 ½	65	161 486 690	161 486 325
90	3	80	161 486 690	161 486 325
110	4	100	161 486 691	161 486 326
140	5	125	161 486 691	161 486 326
160	6	150	161 486 694	161 486 327

table continued next page

d [mm]	Inch	DN [mm]	with index plate Code	with fine adjust- ment Code
225	8	200	161 486 695	161 486 328
280	10	250	161 486 697	
315	12	300	161 486 697	

Profile seal (13) DN350-600

d [mm]	Inch	DN [mm]	EPDM Code	FPM Code
355	14	350	748 440 018	749 440 028
400	16	400	748 440 019	749 440 029
450	18	450	748 440 020	749 440 030
500	20	500	748 440 021	749 440 031
630	24	600	748 440 022	749 440 032

Snap ring DN350-600

- For fixation of profile seal in body

d [mm]	Inch	DN [mm]	PP-H Code
355	14	350	167 484 295
400	16	400	167 484 296
450	18	450	167 484 297
500	20	500	167 484 298
630	24	600	167 484 299

Spare parts butterfly valve type 367

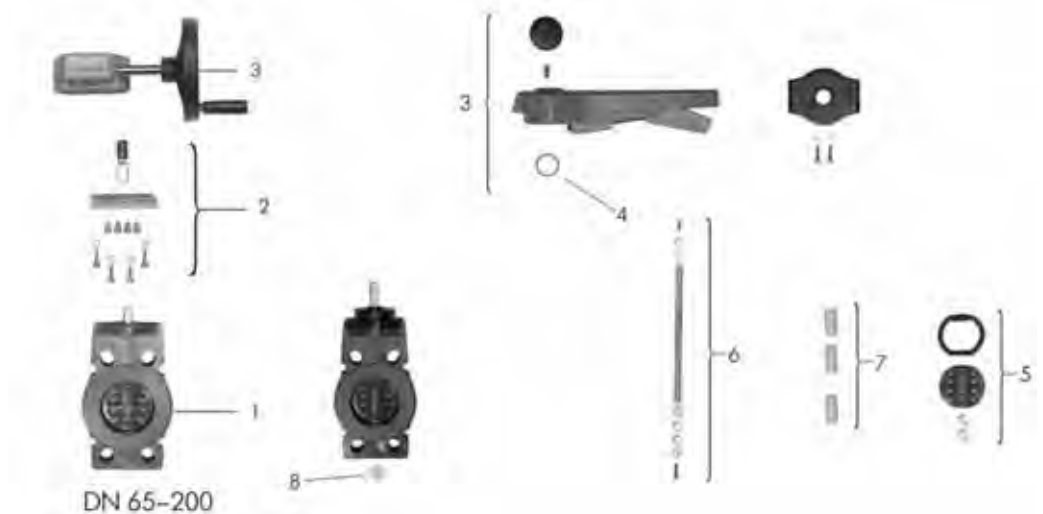

Butterfly valve bare shaft with short shaft (1)

d [mm]	Inch	DN [mm]	PVC-U EPDM metric BS ANSI Code	PVC-U EPDM metric BS Code	PVC-U EPDM ANSI Code
75	2 ½	65	161 367 625		
90	3	80	161 367 626		
110	4	100	161 367 627		
140	5	125	161 367 628		
160	6	150	161 367 629		
225	8	200	161 367 630		
280	10	250		161 367 051	161 367 171
315	12	300		161 367 052	161 367 172



table continued next page

d [mm]	Inch	DN [mm]	PVC-U EPDM JIS Code	PVC-U FPM met- ric BS ANSI Code	PVC-U FPM met- ric BS Code	
75	2 ½	65	161 367 685	161 367 635		
90	3	80	161 367 686	161 367 636		
110	4	100	161 367 687	161 367 637		
140	5	125	161 367 688	161 367 638		
160	6	150	161 367 689	161 367 639		
225	8	200	161 367 690	161 367 640		
280	10	250	161 367 351		161 367 071	
315	12	300	161 367 352		161 367 072	

d [mm]	Inch	DN [mm]	PVC-U FPM ANSI Code	PVC-U FPM JIS Code	ABS EPDM metric BS ANSI Code	PP-H EPDM met- ric BS ANSI Code
75	2 ½	65		161 367 695		167 367 625
90	3	80		161 367 696	169 367 626	167 367 626
110	4	100		161 367 697	169 367 627	167 367 627
140	5	125		161 367 698	169 367 629	167 367 628
160	6	150		161 367 699		167 367 629
225	8	200		161 367 700		167 367 630
280	10	250	161 367 191	161 367 371		
315	12	300	161 367 192	-		

d [mm]	Inch	DN [mm]	PP-H EPDM met- ric Code	PP-H EPDM ANSI Code	PP-H EPDM JIS Code	PP-H FPM metric BS ANSI Code
75	2 ½	65				167 367 635
90	3	80				167 367 636
110	4	100				167 367 637
140	5	125				167 367 638
160	6	150				167 367 639
225	8	200				167 367 640
280	10	250	167 367 051	167 367 171	167 367 351	
315	12	300	167 367 052	-	-	

d [mm]	Inch	DN [mm]	PP-H FPM metric Code	PP-H FPM ANSI Code	PP-H FPM JIS Code	PP-H PTFE/FPM metric BS ANSI Code
75	2 ½	65				167 367 535
90	3	80				167 367 536
110	4	100				167 367 537
140	5	125				167 367 538
160	6	150				167 367 539
225	8	200				167 367 540
280	10	250	167 367 071	167 367 191	167 367 371	
315	12	300	167 367 072	-	-	

d [mm]	Inch	DN [mm]	PVDF FPM metric BS ANSI Code	
75	2 ½	65	175 367 635	
90	3	80	175 367 636	
110	4	100	175 367 637	
140	5	125	175 367 638	
160	6	150	175 367 639	
225	8	200	175 367 640	
280	10	250		
315	12	300		



Disc seal set

Model:

- Disc set consisting of: disc, sealing ring and belleville washer steel galvanized (5)

d [mm]	Inch	DN [mm]	PVC-U EPDM Code	PVC-U FPM Code	PVC-C EPDM Code	PVC-C FPM Code	ABS EPDM Code
75	2 ½	65	161 483 040	161 483 052	-	-	-
90	3	80	161 483 041	161 483 053	163 481 351	163 481 359	169 480 826
110	4	100	161 483 042	161 483 054	163 481 352	163 481 360	169 480 827
140	5	125	161 483 043	161 483 055	-	-	169 480 829
160	6	150	161 483 044	161 483 056	163 481 354	163 481 362	-
225	8	200	161 483 045	161 483 057	163 481 355	163 481 363	-

d [mm]	Inch	DN [mm]	PP-H EPDM Code	PP-H FPM Code	PP-H PTFE/FPM Code	PVDF FPM Code
75	2 ½	65	167 480 909	167 480 917	167 484 012	175 480 910
90	3	80	167 480 910	167 480 918	167 484 013	175 480 911
110	4	100	167 480 911	167 480 919	167 484 014	175 480 912
140	5	125	167 480 912	167 480 920	167 484 015	175 480 913
160	6	150	167 480 913	167 480 921	167 484 016	175 480 914
225	8	200	167 480 914	167 480 922	167 484 017	175 480 915



Disc shaft set DN250-DN300

Model:

- Disc shaft set consisting of: disc and shaft without sealing

d [mm]	Inch	DN [mm]	PVC-U Code	PP-H Code
280	10	250	161 482 656	167 480 931
315	12	300	161 482 657	167 480 932



Seal set DN250-DN300

d [mm]	Inch	DN [mm]	EPDM Code	FPM Code
280	10	250	161 482 664	161 482 668
315	12	300	161 482 665	161 482 669



Bearing bush (7)

d [mm]	Inch	DN [mm]	PVC-U PP T20 Code	PVDF Code
75	2 ½	65	167 480 334	175 480 109
90	3	80	167 480 335	175 480 110
110	4	100	167 480 336	175 480 111
140	5	125	167 480 337	175 480 112
160	6	150	167 480 338	175 480 113

table continued next page

d [mm]	Inch	DN [mm]	PVC-U PP T20 Code	PVDF Code
225	8	200	167 480 339	175 480 114
280	10	250		175 480 805
315	12	300		175 480 805

Shaft set (6)

d [mm]	Inch	DN [mm]	Code
75	2 ½	65	161 483 135
90	3	80	161 483 136
110	4	100	161 483 137
140	5	125	161 483 138
160	6	150	161 483 139
225	8	200	161 483 140



Lever with index plate (3, 4)

d [mm]	Inch	DN [mm]	PVC-U black Code	PVDF Code
75	2 ½	65	161 486 192	175 483 069
90	3	80	161 486 193	175 483 070
110	4	100	161 486 194	175 483 071
140	5	125	161 486 195	175 483 072
160	6	150	161 486 196	175 483 073
225	8	200	161 486 197	175 483 074



Index plate set

Model:

- Index plate set DN80-DN200 with lever, DN250-DN300 without lever

d [mm]	Inch	DN [mm]	PP-H Code
280	10	250	161 484 836
315	12	300	161 484 836



Lever

d [mm]	Inch	DN [mm]	PVC-U Code
280	10	250	161 483 987
315	12	300	161 483 987

Reduction gear with handwheel (3)

d [mm]	Inch	DN [mm]	Code
75	2 ½	65	161 482 408
90	3	80	161 482 408
110	4	100	161 482 408
125	4 ½	125	161 482 408
160	6	150	161 482 408
225	8	200	161 482 408



table continued next page

d [mm]	Inch	DN [mm]	Code
280	10	250	161 483 462
315	12	300	161 483 462
355	14	350	161 483 422
400	16	400	161 483 423
450	18	450	161 483 423
500	20	500	161 483 423
630	24	600	161 483 424

Handwheel for reduction gear (3)



d [mm]	Inch	DN [mm]	Code
75	2 ½	65	161 483 464
90	3	80	161 483 464
110	4	100	161 483 464
125	4 ½	125	161 483 464
160	6	150	161 483 464
225	8	200	161 483 464
280	10	250	161 483 464
315	12	300	161 483 464

Mounting block set (2)

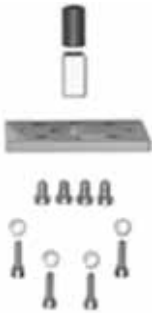

d [mm]	Inch	DN [mm]	PVC-U Code
75	2 ½	65	161 484 768
90	3	80	161 484 769
110	4	100	161 484 770
140	5	125	161 484 771
160	6	150	161 484 772
225	8	200	161 484 773
280	10	250	161 484 774
315	12	300	161 484 774

Plug PE O-ring EPDM (8)

d [mm]	Inch	DN [mm]	PE Code	EPDM Code
75	2 ½	65	161 480 784	748 410 123
90	3	80	161 481 400	748 410 137
110	4	100	161 481 400	748 410 137
140	5	125	161 481 401	748 410 138
160	6	150	161 481 402	748 410 139
225	8	200	161 481 402	748 410 139
280	10	250	161 481 401	748 410 139
315	12	300	161 481 401	748 410 139

Intermediate element

Pneumatic type 240 / 241 / 242 Without manual override

d [mm]	DN [mm]	Type of actuator	Code
63	50	PA30 FC/FO	198 000 595
63	50	PA35 DA	198 000 595
75	65	PA30 FC/FO	198 000 595
75	65	PA35 DA	198 000 595
90	80	PA40 DA	198 000 595
90	80	PA35 FC/FO	198 000 596
110	100	PA40 FC/FO	198 000 600
110	100	PA45 DA	198 000 600
140	125	PA45 DA	198 000 600

table continued next page

d [mm]	DN [mm]	Type of actuator	Code	
140	125	PA45 FC/FO	198 000 597	
160	150	PA55 DA	198 000 600	
160	150	PA50 FC	198 000 599	
225	200	PA55 FC/FO	198 000 598	
225	200	PA55 DA	198 000 600	
280	250	FA65 FC/FO	198 000 730	
280	250	PA65 DA	198 000 731	
315	300	PA70 FC/FO	198 000 730	
315	300	PA70 DA	198 000 731	

Pneumatic type 240 / 241 / 242 With manual override

d [mm]	DN [mm]	Type of actuator	Code	
63	50	PA30 FC/FO	198 000 630	
63	50	PA35 DA	198 000 630	
75	65	PA30 FC/FO	198 000 630	
75	65	PA35 DA	198 000 630	
90	80	PA40 DA	198 000 631	
90	80	PA35 FC/FO	198 000 630	
110	100	PA40 FC/FO	198 000 628	
110	100	PA45 DA	198 000 628	
140	125	PA45 DA	198 000 629	
140	125	PA45 FC/FO	198 000 628	
160	150	PA55 DA	198 000 625	
160	150	PA50 FC	198 000 625	
225	200	PA55 FC/FO	198 000 627	
225	200	PA55 DA	198 000 625	

Electric type 140 / 141 / 142 Without manual override

d [mm]	DN [mm]	Type of actuator	Code	
63	50	EA31	198 000 601	
75	65	EA31	198 000 601	
90	80	EA31	198 000 601	
110	100	EA31	198 000 602	
140	125	EA31	198 000 602	
160	150	EA31	198 000 599	
225	200	EA42	198 000 603	
280	250	EA42	198 000 732	
315	300	EA42	198 000 732	

Electric type 140 / 141 / 142 With manual override

d-d [mm]	DN-DN [mm]	Type of actuator	Code	
63 - 90	50 - 80	EA31	198 000 623	
110 - 140	100 - 125	EA31	198 000 624	
- 160	- 150	EA31	198 000 625	
- 225	- 200	EA42	198 000 627	

Gear operated with handwheel 567 / 568

d [mm]	DN [mm]	Code	
63	50	198 000 621	
75	65	198 000 621	
90	80	198 000 621	
110	100	198 000 622	

table continued next page

d [mm]	DN [mm]	Code	
140	125	198 000 622	
160	150	198 000 599	
225	200	198 000 599	
280	250	198 000 880	
315	300	198 000 880	

Reduction gear with handwheel



d [mm]	Inch	DN [mm]	Code	
75	2 ½	65	161 482 408	
90	3	80	161 482 408	
110	4	100	161 482 408	
125	4 ½	125	161 482 408	
160	6	150	161 482 408	
225	8	200	161 482 408	
280	10	250	161 483 462	
315	12	300	161 483 462	

Spare parts diaphragm valves new generation

Spare parts for hand-operated valves Type 514/515/517/519



Bonnet complete



d [mm]	Inch	DN [mm]	Standard configuration PN10 Code	For pressure tight housing PN10 Code	Standard configuration PN16 Code
20	1/2	15	198 151 742	198 151 752	198 151 842
25	3/4	20	198 151 743	198 151 753	198 151 843
32	1	25	198 151 744	198 151 754	198 151 844
40	1 1/4	32	198 151 745	198 151 755	198 151 845
50	1 1/2	40	198 151 746	198 151 756	198 151 846
63	2	50	198 151 747	198 151 757	198 151 847

d [mm]	Inch	DN [mm]	For pressure tight housing PN16 Code
20	1/2	15	198 151 852
25	3/4	20	198 151 853
32	1	25	198 151 854
40	1 1/4	32	198 151 855
50	1 1/2	40	198 151 856
63	2	50	198 151 857

Hand wheel

Model:

- Without position indicator



DN [mm]	Code
15 - 20	198 204 162
25 - 32	198 204 164
40 - 50	198 104 166

Position indicator



d [mm]	Inch	DN [mm]	Code
20	¾	15	167 484 992
25	¾	20	167 484 993
32	1	25	167 484 994
40	1 ¼	32	167 484 995
50	1 ½	40	167 484 996
63	2	50	167 484 997

Spindle assembly



Model:

- Incl. position indicator and compressor

DN-DN [mm]	Code
15 - 20	198 204 327
25 - 32	198 204 328
40 - 50	198 204 329

Seal set



Model:

- For manual valve - pressure tight housing
- Incl. position indicator

d [mm]	Inch	DN [mm]	EPDM Code
20	¾	15	198 000 892
25	¾	20	198 000 893
32	1	25	198 000 894
40	1 ¼	32	198 000 895
50	1 ½	40	198 000 896
63	2	50	198 000 897

Spare parts for automatic valves Diastar Six/Ten/Sixteen



Actuators



d [mm]	Inch	DN [mm]	Diastar Six Code	Diastar Ten Code	Diastar Ten+ FC Code	Diastar Sixteen FC Code
20	½	15	198 151 762	198 151 772	198 153 062	198 151 782
25	¾	20	198 151 763	198 151 773	198 153 063	198 151 783
32	1	25	198 151 764	198 151 774	198 153 064	198 151 784
40	1 ¼	32	198 151 765	198 151 775	198 153 065	198 151 785
50	1 ½	40	198 151 766	198 151 776	198 153 066	198 151 786
63	2	50	198 151 767	198 151 777	198 153 067	198 151 787

d [mm]	Inch	DN [mm]	Diastar Ten FO Code	Diastar Ten DA Code
20	½	15	198 151 792	198 151 802
25	¾	20	198 151 793	198 151 803
32	1	25	198 151 794	198 151 804
40	1 ¼	32	198 151 795	198 151 805
50	1 ½	40	198 151 796	198 151 806
63	2	50	198 151 797	198 151 807

Indicator cap



Size	Code
1-2	198 806 639
3-5	198 806 640



Compressor set

Model:

- Incl. diaphragm holder

d [mm]	Inch	DN [mm]	Code
20	1/2	15	198 000 872
25	3/4	20	198 000 873
32	1	25	198 000 874
40	1 1/4	32	198 000 875
50	1 1/2	40	198 000 876
63	2	50	198 000 877



Seal set

Model:

- Spindle seal and piston seal

Size	Diastar Six/Ten/ Sixteen Code	Only for Diastar Six DN40/DN50 Code
Gr. 1	198 000 881	-
Gr. 2	198 000 882	-
Gr. 3	198 000 883	198 000 886
Gr. 4	198 000 884	-
Gr. 5	198 000 885	-



Spare parts diaphragm

For type 514/515/517/519

d [mm]	Inch	DN [mm]	NBR Code	EPDM Code	FPM Code	PTFE/EPDM Code	PTFE/EPDM HP Code
20	1/2	15	745 500 012	748 500 012	749 500 012	747 502 012	747 502 032
25	3/4	20	745 500 013	748 500 013	749 500 013	747 502 013	747 502 033
32	1	25	745 500 014	748 500 014	749 500 014	747 502 014	747 502 034
40	1 1/4	32	745 500 015	748 500 015	749 500 015	747 502 015	747 502 035
50	1 1/2	40	745 500 016	748 500 016	749 500 016	747 502 016	747 502 036
63	2	50	745 500 017	748 500 017	749 500 017	747 502 017	747 502 037

d [mm]	Inch	DN [mm]	PTFE/FPM Code
20	1/2	15	747 503 012
25	3/4	20	747 503 013
32	1	25	747 503 014
40	1 1/4	32	747 503 015
50	1 1/2	40	747 503 016
63	2	50	747 503 017

Spare parts for valve body type 514

Valve body with true union

Model:

- Without connection parts



d [mm]	Inch	DN [mm]	PVC-U Code	PVC-C Code	ABS Code	PP-H Code	PVDF Code	
20	½	15	161 492 062	163 482 052	169 481 322	167 483 522	175 483 682	
25	¾	20	161 492 063	163 482 053	169 481 323	167 483 523	175 483 683	
32	1	25	161 492 064	163 482 054	169 481 324	167 483 524	175 483 684	
40	1 ¼	32	161 492 065	163 482 055	169 481 325	167 483 525	175 483 685	
50	1 ½	40	161 492 066	163 482 056	169 481 326	167 483 526	175 483 686	
63	2	50	161 492 067	163 482 057	169 481 327	167 483 527	175 483 687	

d [mm]	Inch	DN [mm]	PVDF HP Code	
20	½	15	180 001 002	
25	¾	20	180 001 003	
32	1	25	180 001 004	
40	1 ¼	32	180 001 005	
50	1 ½	40	180 001 006	
63	2	50	180 001 007	

Union end



d [mm]	Inch	DN [mm]	PVC-U metric Code	PVC-U JIS Code	PVC-U BS Code	PVC-U ASTM Code	ABS metric Code	
20	½	15	721 500 106	721 605 106	721 601 106	721 602 006	729 800 106	
25	¾	20	721 500 107	721 605 107	721 601 107	721 602 007	729 800 107	
32	1	25	721 500 108	721 605 108	721 601 108	721 602 008	729 800 108	
40	1 ¼	32	721 500 109	721 605 109	721 601 109	721 602 009	729 800 109	
50	1 ½	40	721 500 110	721 605 110	721 601 110	721 602 010	729 800 110	
63	2	50	721 500 111	721 605 111	721 601 111	721 602 011	729 800 111	

d [mm]	Inch	DN [mm]	PP-H metric Code	PVDF metric Code	PVC-C metric Code	PVC-C ANSI Code	ABS BS Code	
20	½	15	727 500 106	735 600 106	723 800 106	723 602 006	729 601 106	
25	¾	20	727 500 107	735 600 107	723 800 107	723 602 007	729 601 107	
32	1	25	727 500 108	735 600 108	723 800 108	723 602 008	729 601 108	
40	1 ¼	32	727 500 109	735 600 109	723 800 109	723 602 009	729 601 109	
50	1 ½	40	727 500 110	735 600 110	723 800 110	723 602 010	729 601 110	
63	2	50	727 500 111	735 600 111	723 800 111	723 602 011	729 601 111	

Valve end with spigot



d [mm]	Inch	DN [mm]	PVC-U Code	PP-H SDR11 Code	PVDF Code	PE100 SDR11 Code	PE100 long Code	
20	½	15	721 600 406	727 508 506	735 608 606	753 508 606	753 508 616	
25	¾	20	721 600 407	727 508 507	735 608 607	753 508 607	753 508 617	
32	1	25	721 600 408	727 508 508	735 608 608	753 508 608	753 508 618	
40	1 ¼	32	721 600 409	727 508 509	735 608 609	753 508 609	753 508 619	
50	1 ½	40	721 600 410	727 508 510	735 608 610	753 508 610	753 508 620	
63	2	50	721 600 411	727 508 511	735 608 611	753 508 611	753 508 621	

Union nut



d [mm]	Inch	DN [mm]	PVC-U Code	PVC-C Code	ABS Code	PP-H Code	PVDF Code	
20	½	15	721 890 006	723 690 006	729 890 406	727 890 406	735 690 406	
25	¾	20	721 890 007	723 690 007	729 890 407	727 890 407	735 690 407	
32	1	25	721 890 008	723 690 008	729 890 408	727 890 408	735 690 408	
40	1 ¼	32	721 890 009	723 690 009	729 890 409	727 890 409	735 690 409	
50	1 ½	40	721 890 010	723 690 010	729 890 410	727 890 410	735 690 410	
63	2	50	721 890 011	723 690 011	729 890 411	727 890 411	735 690 411	



O-ring

d [mm]	Inch	DN [mm]	EPDM Code	FPM Code	FPM for PVDF standard Code	FPM for PVDF-HP Code
20	½	15	748 410 006	749 410 006	749 410 005	749 411 005
25	¾	20	748 410 007	749 410 007	749 410 006	749 411 006
32	1	25	748 410 008	749 410 008	749 410 120	749 411 120
40	1 ¼	32	748 410 009	749 410 009	749 410 062	749 411 062
50	1 ½	40	748 410 010	749 410 010	749 410 172	749 411 172
63	2	50	748 410 011	749 410 011	749 410 054	749 411 054

Spare parts for valve body type 515

Valve body with spigot ends



d [mm]	Inch	DN [mm]	PVC-U solvent ce- ment spigot Code	PVC-C solvent ce- ment spigot Code	ABS solvent ce- ment spigot Code
20	½	15	161 492 072	163 482 062	169 481 862
25	¾	20	161 492 073	163 482 063	169 481 863
32	1	25	161 492 074	163 482 064	169 481 864
40	1 ¼	32	161 492 075	163 482 065	169 481 865
50	1 ½	40	161 492 076	163 482 066	169 481 866
63	2	50	161 492 077	163 482 067	169 481 867



d [mm]	Inch	DN [mm]	PP-H socket fu- sion spigot Code	PP-H butt fusion spigot IR Code	PP-N butt fusion spigot IR Code
20	½	15	167 483 342	167 483 882	168 480 462
25	¾	20	167 483 343	167 483 883	168 480 463
32	1	25	167 483 344	167 483 884	168 480 464
40	1 ¼	32	167 483 345	167 483 885	168 480 465
50	1 ½	40	167 483 346	167 483 886	168 480 466
63	2	50	167 483 347	167 483 887	168 480 467



d [mm]	Inch	DN [mm]	PVDF socket fu- sion spigot Code	PVDF butt fusion spigot IR Code	PVDF-HP butt fu- sion spigot IR Code
20	½	15	175 483 692	175 483 742	180 001 012
25	¾	20	175 483 693	175 483 743	180 001 013
32	1	25	175 483 694	175 483 744	180 001 014
40	1 ¼	32	175 483 695	175 483 745	180 001 015
50	1 ½	40	175 483 696	175 483 746	180 001 016
63	2	50	175 483 697	175 483 747	180 001 017

Spare parts for valve body type 517

Valve body with flange connection



d [mm]	Inch	DN [mm]	PVC-U JIS Code	PP-H JIS Code	PVDF JIS Code
20	½	15	161 480 282	167 484 402	175 483 532
25	¾	20	161 480 283	167 484 403	175 483 533
32	1	25	161 480 284	167 484 404	175 483 534
40	1 ¼	32	161 480 285	167 484 405	175 483 535
50	1 ½	40	161 480 286	167 484 406	175 483 536
63	2	50	161 480 287	167 484 407	175 483 537



Flange adaptor flat

d [mm]	Inch	DN [mm]	PVC-U metric Code	PVC-C metric Code	ABS metric Code	PP-H metric Code	
20	½	15	721 800 106	723 790 106	729 790 106	727 790 206	
25	¾	20	721 800 107	723 790 107	729 790 107	727 790 207	
32	1	25	721 800 108	723 790 108	729 790 108	727 790 208	
40	1 ¼	32	721 800 109	723 790 109	729 790 109	727 790 209	
50	1 ½	40	721 800 110	723 790 110	729 790 110	727 790 210	
63	2	50	721 790 111	723 790 111	729 790 111	727 790 211	

d [mm]	Inch	DN [mm]	PVDF metric Code	
20	½	15	735 790 206	
25	¾	20	735 790 207	
32	1	25	735 790 208	
40	1 ¼	32	735 790 209	
50	1 ½	40	735 790 210	
63	2	50	735 790 211	



Flange

d [mm]	Inch	DN [mm]	PVC-U metric Code	PVC-U ASTM Code	PP-V metric Code	PP-V ASTM Code	PP-ST metric Code
20	½	15	721 700 006	721 702 206	727 700 406	727 701 406	727 700 206
25	¾	20	721 700 007	721 702 207	727 700 407	727 701 407	727 700 207
32	1	25	721 700 008	721 702 208	727 700 408	727 701 408	727 700 208
40	1 ¼	32	721 700 009	721 702 209	727 700 409	727 701 409	727 700 209
50	1 ½	40	721 700 010	721 702 210	727 700 410	727 701 410	727 700 210
63	2	50	721 700 011	721 702 211	727 700 411	727 701 411	727 700 211

d [mm]	Inch	DN [mm]	PP-ST ASTM Code
20	½	15	727 701 206
25	¾	20	727 701 207
32	1	25	727 701 208
40	1 ¼	32	727 701 209
50	1 ½	40	727 701 210
63	2	50	727 701 211



Flat gasket

d [mm]	Inch	DN [mm]	EPDM Code	FPM Code
20	½	15	748 400 006	749 400 006
25	¾	20	748 400 007	749 400 007
32	1	25	748 400 008	749 400 008
40	1 ¼	32	748 400 009	749 400 009
50	1 ½	40	748 400 010	749 400 010
63	2	50	748 400 011	749 400 011

Spare parts for valve body type 519

Valve body with butt fusion spigot



d [mm]	Inch	PP-H Code	PP-Natur Code	PVDF-HP Code
20 - 20	½	167 485 911	168 480 601	180 001 101
25 - 20	¾	167 485 912	168 480 602	180 001 102
25 - 25	¾	167 485 913	168 480 603	180 001 103
32 - 20	1	167 485 914	168 480 604	180 001 104
32 - 25	1	167 485 915	168 480 605	180 001 105
32 - 32	1	167 485 916	168 480 606	180 001 106
40 - 20	1 ¼	167 485 917	168 480 607	180 001 107
40 - 25	1 ¼	-	-	180 001 108
40 - 32	1 ¼	-	-	180 001 109

table continued next page

d [mm]	Inch	PP-H Code	PP-Natur Code	PVDF-HP Code	
40 - 40	1 ¼	-	-	180 001 110	
50 - 20	1 ½	167 485 922	168 480 611	180 001 111	
50 - 25	1 ½	167 485 923	168 480 612	180 001 112	
50 - 32	1 ½	167 485 924	168 480 613	180 001 113	
50 - 40	1 ½	-	-	180 001 114	
50 - 50	1 ½	-	-	180 001 115	
63 - 20	2	167 485 927	168 480 616	180 001 116	
63 - 25	2	167 485 928	168 480 617	180 001 117	
63 - 32	2	167 485 929	168 480 618	180 001 118	
63 - 40	2	-	-	180 001 119	
63 - 50	2	-	-	180 001 120	
63 - 63	2	-	-	180 001 121	
90 - 25	3	-	-	180 001 126	
90 - 32	3	-	-	180 001 127	
90 - 50	3	-	-	180 001 128	
90 - 63	3	-	-	180 001 129	
110 - 20	4	-	-	180 001 130	
110 - 25	4	-	-	180 001 131	
110 - 32	4	-	-	180 001 132	
110 - 50	4	-	-	180 001 133	
110 - 63	4	-	-	180 001 134	

Spare parts diaphragm valves

Spare parts diaphragm valve type 314



Bonnet complete

Model:

- Without diaphragm (1, 3)



d [mm]	Inch	DN [mm]	elastomer diaphragm Code	PTFE diaphragm Code
20	½	15	161 484 625	161 484 632
25	¾	20	161 484 626	161 484 633
32	1	25	161 484 627	161 484 634
40	1 ¼	32	161 484 628	161 484 635
50	1 ½	40	161 484 629	161 484 636
63	2	50	161 484 630	161 484 637

Diaphragm (2)



d [mm]	Inch	DN [mm]	NBR Code	EPDM Code	FPM Code	PTFE/EPDM Code	PTFE/FPM Code
20	½	15	161 311 710	161 481 022	161 481 092	161 311 698	161 481 926
25	¾	20	161 311 711	161 481 023	161 481 093	161 311 699	161 481 927
32	1	25	161 311 712	161 481 024	161 481 094	161 311 700	161 481 928
40	1 ¼	32	161 311 713	161 481 025	161 481 095	161 311 701	161 481 929
50	1 ½	40	161 311 714	161 481 026	161 481 096	161 311 702	161 481 930
63	2	50	161 311 715	161 481 027	161 481 097	161 311 703	161 481 931

d [mm]	Inch	DN [mm]	CSM Code	PTFE/EPDM SYGEF PLUS HP Code
20	½	15	161 311 728	161 484 452
25	¾	20	161 311 729	161 484 453
32	1	25	161 311 730	161 484 454
40	1 ¼	32	161 311 731	161 484 455
50	1 ½	40	161 311 732	161 484 456
63	2	50	161 311 733	161 484 457

Pressure spindle (3)



d [mm]	Inch	DN [mm]	elastomer diaphragm Code	PTFE diaphragm Code
20	½	15	161 484 688	161 484 696
25	¾	20	161 484 689	161 484 697
32	1	25	161 484 690	161 484 698
40	1 ¼	32	161 484 691	161 484 699
50	1 ½	40	161 484 692	161 484 700
63	2	50	161 484 693	161 484 701



Fastening set (4)

Model:

- * with support plate

d [mm]	Inch	DN [mm]	for PVC-U PVC-C ABS Code	for PP PVDF *	Code
20	½	15	161 484 704	198 000 650	
25	¾	20	161 484 705	198 000 651	
32	1	25	161 484 706	198 000 652	
40	1 ¼	32	161 484 707	198 000 653	
50	1 ½	40	161 484 708	198 000 654	
63	2	50	161 484 709	198 000 655	



Valve body (5)

d [mm]	Inch	DN [mm]	PVC-U Code	PP-H Code	PVDF Code
20	½	15	161 481 218	167 481 977	175 481 977
25	¾	20	161 481 219	167 481 978	175 481 978
32	1	25	161 481 220	167 481 979	175 481 979
40	1 ¼	32	161 481 221	167 481 980	175 481 980
50	1 ½	40	161 481 222	167 481 981	175 481 981
63	2	50	161 481 223	167 481 982	175 481 982



Union nut

d [mm]	Inch	DN [mm]	PVC-U Code	PP-H Code	PVDF Code
20	½	15	721 690 006	727 690 406	735 690 406
25	¾	20	721 690 007	727 690 407	735 690 407
32	1	25	721 690 008	727 690 408	735 690 408
40	1 ¼	32	721 690 009	727 690 409	735 690 409
50	1 ½	40	721 690 010	727 690 410	735 690 410
63	2	50	721 690 011	727 690 411	735 690 411



Valve end

d [mm]	Inch	DN [mm]	PVC-U metric Code	PVC-U JIS Code	PVC-U BS Code	PVC-U ASTM Code	PP-H metric Code
20	½	15	721 600 106	721 605 106	721 601 106	721 602 006	727 600 106
25	¾	20	721 600 107	721 605 107	721 601 107	721 602 007	727 600 107
32	1	25	721 600 108	721 605 108	721 601 108	721 602 008	727 600 108
40	1 ¼	32	721 600 109	721 605 109	721 601 109	721 602 009	727 600 109
50	1 ½	40	721 600 110	721 605 110	721 601 110	721 602 010	727 600 110
63	2	50	721 600 111	721 605 111	721 601 111	721 602 011	727 600 111

d [mm]	Inch	DN [mm]	PVDF metric Code	PE80 Code
20	½	15	735 600 106	734 600 106
25	¾	20	735 600 107	734 600 107
32	1	25	735 600 108	734 600 108
40	1 ¼	32	735 600 109	734 600 109
50	1 ½	40	735 600 110	734 600 110
63	2	50	735 600 111	734 600 111



Valve end with spigot

d [mm]	Inch	DN [mm]	PVC-U Code	PP-H SDR11 Code	PVDF Code	PE100 SDR11 Code	PE100 long Code
20	½	15	721 600 406	727 508 506	735 608 606	753 508 606	753 508 616
25	¾	20	721 600 407	727 508 507	735 608 607	753 508 607	753 508 617
32	1	25	721 600 408	727 508 508	735 608 608	753 508 608	753 508 618
40	1 ¼	32	721 600 409	727 508 509	735 608 609	753 508 609	753 508 619
50	1 ½	40	721 600 410	727 508 510	735 608 610	753 508 610	753 508 620
63	2	50	721 600 411	727 508 511	735 608 611	753 508 611	753 508 621



Threaded bush

Rp [inch]	DN [mm]	PVC-U Rp Code	PVC-U NPT Code	PVC-U blind Code
½	15	721 600 656	721 602 656	721 600 006
¾	20	721 600 657	721 602 657	721 600 007
1	25	721 600 658	721 602 658	721 600 008
1 ¼	32	721 600 659	721 602 659	721 600 009
1 ½	40	721 600 660	721 602 660	721 600 010
2	50	721 600 661	721 602 661	721 600 011



Union end seal for PVC-U valves

d [mm]	Inch	DN [mm]	EPDM Code	FPM Code
20	½	15	748 410 038	749 410 038
25	¾	20	748 410 044	749 410 044
32	1	25	748 410 195	749 410 195
40	1 ¼	32	748 410 052	749 410 052
50	1 ½	40	748 410 134	749 410 134
63	2	50	748 410 135	749 410 135



Union end seal for PP-H and PVDF valves

d [mm]	Inch	DN [mm]	EPDM Code	FPM Code
20	½	15	748 410 006	749 410 006
25	¾	20	748 410 007	749 410 007
32	1	25	748 410 008	749 410 008
40	1 ¼	32	748 410 009	749 410 009
50	1 ½	40	748 410 010	749 410 010
63	2	50	748 410 011	749 410 011

Spare parts diaphragm valve type 315

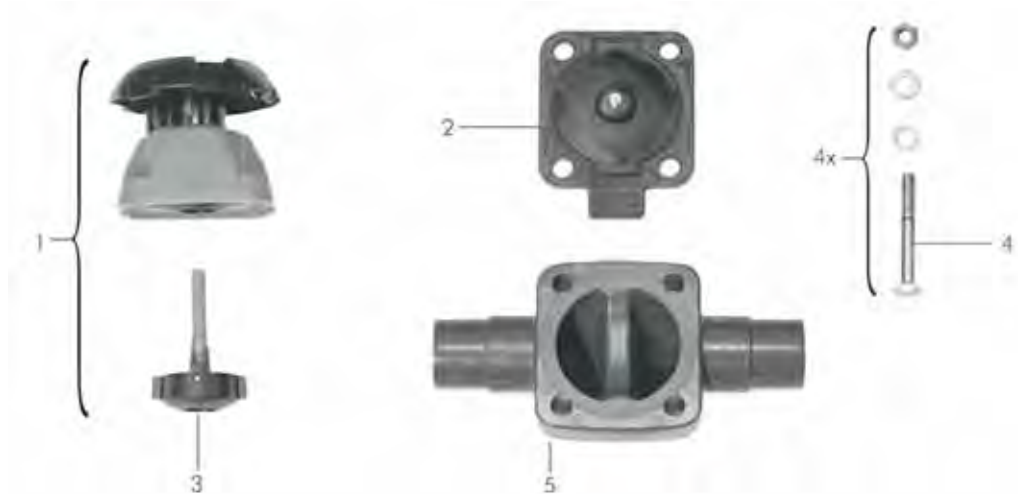

Bonnet complete

Model:

- Without diaphragm (1, 3)



d [mm]	Inch	DN [mm]	elastomer diaphragm Code	PTFE diaphragm Code
20	1/2	15	161 484 625	161 484 632
25	3/4	20	161 484 626	161 484 633
32	1	25	161 484 627	161 484 634
40	1 1/4	32	161 484 628	161 484 635
50	1 1/2	40	161 484 629	161 484 636
63	2	50	161 484 630	161 484 637

Diaphragm (2)



d [mm]	Inch	DN [mm]	NBR Code	EPDM Code	FPM Code	PTFE/EPDM Code	PTFE/FPM Code
20	1/2	15	161 311 710	161 481 022	161 481 092	161 311 698	161 481 926
25	3/8	20	161 311 711	161 481 023	161 481 093	161 311 699	161 481 927
32	1	25	161 311 712	161 481 024	161 481 094	161 311 700	161 481 928
40	1 1/4	32	161 311 713	161 481 025	161 481 095	161 311 701	161 481 929
50	1 1/2	40	161 311 714	161 481 026	161 481 096	161 311 702	161 481 930
63	2	50	161 311 715	161 481 027	161 481 097	161 311 703	161 481 931

d [mm]	Inch	DN [mm]	CSM Code	PTFE/EPDM SYGEF PLUS HP Code
20	1/2	15	161 311 728	161 484 452
25	3/8	20	161 311 729	161 484 453
32	1	25	161 311 730	161 484 454
40	1 1/4	32	161 311 731	161 484 455
50	1 1/2	40	161 311 732	161 484 456
63	2	50	161 311 733	161 484 457

Pressure spindel (3)



d [mm]	Inch	DN [mm]	elastomer diaphragm Code	PTFE diaphragm Code
20	1/2	15	161 484 688	161 484 696
25	3/4	20	161 484 689	161 484 697
32	1	25	161 484 690	161 484 698
40	1 1/4	32	161 484 691	161 484 699
50	1 1/2	40	161 484 692	161 484 700
63	2	50	161 484 693	161 484 701



Fastening set (4)

Model:

- * with support plate

d [mm]	Inch	DN [mm]	for PVC-U PVC-C ABS Code	for PP PVDF * Code
20	½	15	161 484 704	198 000 650
25	¾	20	161 484 705	198 000 651
32	1	25	161 484 706	198 000 652
40	1 ¼	32	161 484 707	198 000 653
50	1 ½	40	161 484 708	198 000 654
63	2	50	161 484 709	198 000 655



Valve body metric (5)

d [mm]	Inch	DN [mm]	PVC-U solvent ce- ment spigot Code	PVC-C solvent ce- ment spigot Code	ABS solvent ce- ment spigot Code
20	½	15	161 481 274	163 480 271	169 480 162
25	¾	20	161 481 275	163 480 272	169 480 163
32	1	25	161 481 276	163 480 273	169 480 164
40	1 ¼	32	161 481 277	163 480 274	169 480 165
50	1 ½	40	161 481 278	163 480 275	169 480 166
63	2	50	161 481 279	163 480 276	169 480 167
75	2 ½	65			169 480 281

d [mm]	Inch	DN [mm]	PP-H socket fu- sion spigot Code	PP-H butt fusion spigot Code	PP-N butt fusion spigot Code
20	½	15	167 480 328	167 481 175	168 480 125
25	¾	20	167 480 329	167 481 176	168 480 126
32	1	25	167 480 330	167 481 177	168 480 127
40	1 ¼	32	167 480 331	167 481 178	168 480 128
50	1 ½	40	167 480 332	167 481 179	168 480 129
63	2	50	167 480 333	167 481 180	168 480 130
75	2 ½	65			

d [mm]	Inch	DN [mm]	PVDF socket fu- sion spigot Code	PVDF butt fusion spigot IR Code	PVDF-HP butt fu- sion spigot IR Code
20	½	15	175 480 069	175 481 840	175 481 850
25	¾	20	175 480 070	175 481 841	175 481 851
32	1	25	175 480 071	175 481 842	175 481 852
40	1 ¼	32	175 480 072	175 481 843	175 481 853
50	1 ½	40	175 480 073	175 481 844	175 481 854
63	2	50	175 480 074	175 481 845	175 481 855
75	2 ½	65			



Valve body BS/ASTM (5)

Inch	DN [mm]	PVC-U solvent ce- ment spigot Code	PVC-C solvent ce- ment spigot Code	ABS solvent ce- ment spigot Code
½	15	161 481 286	163 480 135	169 480 050
¾	20	161 481 287	163 480 136	169 480 051
1	25	161 481 288	163 480 137	169 480 052
1 ¼	32	161 481 289	163 480 138	169 480 053
1 ½	40	161 481 290	163 480 139	169 480 054
2	50	161 481 291	163 480 140	169 480 055

Spare parts diaphragm valve type 317



Bonnet complete

Model:

- Without diaphragm (1, 3)



d [mm]	Inch	DN [mm]	elastomer diaphragm Code	PTFE diaphragm Code
20	1/2	15	161 484 625	161 484 632
25	3/4	20	161 484 626	161 484 633
32	1	25	161 484 627	161 484 634
40	1 1/4	32	161 484 628	161 484 635
50	1 1/2	40	161 484 629	161 484 636
63	2	50	161 484 630	161 484 637
75	2 1/2	65	161 484 631	161 484 638
90	3	80	161 482 514	161 482 516
110	4	100	161 482 515	161 482 517
160	6	150	161 482 901	161 482 906

Diaphragm (2)



d [mm]	Inch	DN [mm]	NBR Code	EPDM Code	FPM Code	PTFE/EPDM Code	PTFE/FPM Code
20	1/2	15	161 311 710	161 481 022	161 481 092	161 311 698	161 481 926
25	3/4	20	161 311 711	161 481 023	161 481 093	161 311 699	161 481 927
32	1	25	161 311 712	161 481 024	161 481 094	161 311 700	161 481 928
40	1 1/4	32	161 311 713	161 481 025	161 481 095	161 311 701	161 481 929
50	1 1/2	40	161 311 714	161 481 026	161 481 096	161 311 702	161 481 930
63	2	50	161 311 715	161 481 027	161 481 097	161 311 703	161 481 931
75	2 1/2	65	161 480 231	161 481 028	161 481 098	161 480 240	161 481 932
90	3	80	161 480 232	161 481 029	161 481 099	161 480 241	-
110	4	100	161 480 233	161 481 030	161 481 100	161 480 242	-
160	6	150	161 482 751	161 482 754	161 481 102	161 482 760	-

d [mm]	Inch	DN [mm]	PTFE/EPDM HP Code	CSM Code
20	1/2	15	161 484 452	161 311 728
25	3/4	20	161 484 453	161 311 729
32	1	25	161 484 454	161 311 730
40	1 1/4	32	161 484 455	161 311 731
50	1 1/2	40	161 484 456	161 311 732
63	2	50	161 484 457	161 311 733
75	2 1/2	65	161 484 458	161 480 237
90	3	80	161 484 459	161 480 238
110	4	100	161 484 460	161 480 239
160	6	150	161 482 760	161 482 757



Pressure spindle (3)

d [mm]	Inch	DN [mm]	elastomer di- aphragm Code	PTFE diaphragm Code
20	½	15	161 484 688	161 484 696
25	¾	20	161 484 689	161 484 697
32	1	25	161 484 690	161 484 698
40	1 ¼	32	161 484 691	161 484 699
50	1 ½	40	161 484 692	161 484 700
63	2	50	161 484 693	161 484 701
75	2 ½	65	161 484 694	161 484 702
90	3	80	161 483 008	161 483 020
110	4	100	161 483 009	161 483 021
125	6	150	161 483 011	161 483 023



Fastening set (4)

Model:

- * with support plate

d [mm]	Inch	DN [mm]	for PVC-U PVC-C ABS Code	for PP PVDF * Code
20	½	15	161 484 704	198 000 650
25	¾	20	161 484 705	198 000 651
32	1	25	161 484 706	198 000 652
40	1 ¼	32	161 484 707	198 000 653
50	1 ½	40	161 484 708	198 000 654
63	2	50	161 484 709	198 000 655
75	2 ½	65	161 483 032	161 483 032
90	3	80	161 483 033	161 483 033
110	4	100	161 483 034	161 483 034
160	6	150	161 483 037	161 483 037



Valve body with backing/fixed flange (5)

Inch	d [mm]	DN [mm]	PVC-U metric Code	PVC-U JIS Code	PVC-U BS Code	PVC-U ANSI B16.5 Code
½	20	15	161 483 110	161 483 978	161 483 110	161 484 743
¾	25	20	161 483 111	161 483 979	161 483 111	161 484 744
1	32	25	161 483 112	161 483 980	161 483 112	161 484 745
1 ¼	40	32	161 483 113	161 483 981	161 483 113	161 484 746
1 ½	50	40	161 483 114	161 483 982	161 483 114	161 484 747
2	63	50	161 483 115	161 483 983	161 483 115	161 484 748
2 ½	75	65	161 483 116	161 483 984	161 483 116	161 484 749
3	90	80	161 481 764	161 482 400	161 481 764	
4	110	100	161 481 765	161 482 401	161 481 765	
6	160	150	161 482 696	161 482 696	161 481 696	

Inch	d [mm]	DN [mm]	PVC-C metric Code	ABS ANSI Code	PP-H metric Code	PP-H ANSI Code	PP-GF JIS Code
½	20	15	163 480 808		167 484 025	167 484 035	167 481 552
¾	25	20	163 480 809		167 484 026	167 484 036	167 481 553
1	32	25	163 480 810		167 484 027	167 484 037	167 481 554
1 ¼	40	32	163 480 811		167 484 028	167 484 038	167 481 555
1 ½	50	40	163 480 812		167 484 029	167 484 039	167 481 556
2	63	50	163 480 813		167 484 030	167 484 040	167 481 557
2 ½	75	65	163 480 814		167 484 031	167 484 041	
3	90	80	163 480 677	169 480 282	167 480 427	167 480 427	
4	110	100	163 480 678	169 480 283	167 480 428	167 480 428	167 480 476
6	160	150			167 480 577	167 480 577	167 480 577

table continued next page

Inch	d [mm]	DN [mm]	PVDF metric Code	PVDF ANSI Code	PVDF JIS Code	PP-V/PP-GF met- ric Code
½	20	15	175 482 975	-	175 481 943	169 480 392
¾	25	20	175 482 976	-	175 481 944	
1	32	25	175 482 977	-	175 481 945	
1 ¼	40	32	175 482 978	-	175 481 946	
1 ½	50	40	175 482 979	-	175 481 947	
2	63	50	175 482 980	-	175 481 948	
2 ½	75	65	175 482 981	-	175 481 949	
3	90	80	175 480 189	-	175 480 737	
4	110	100	175 480 190	175 480 748	175 480 738	
6	160	150	175 481 002	175 481 002	175 481 002	



O-ring seal (6)

d [mm]	Inch	DN [mm]	EPDM Code	NBR Code
90	3	80	-	745 410 107
110	4	100	-	745 410 107
160	6	150	748 410 212	-

Indicator cap (7)

d [mm]	Inch	DN [mm]	PVC-U SAN Code
90	3	80	161 481 759
110	4	100	161 481 760
160	6	150	161 482 744

Spare parts diaphragm valve type 319



Bonnet complete

Model:

- Without diaphragm (1, 3)



d [mm]	Inch	elastomer diaphragm Code	PTFE diaphragm Code
20-20	½	161 484 625	161 484 632
25-20	¾	161 484 626	161 484 633
25-25	¾	161 484 626	161 484 633
32-20	1	161 484 627	161 484 634
32-25	1	161 484 627	161 484 634
32-32	1	161 484 627	161 484 634
40-20	1 ¼	161 484 627	161 484 634
40-25	1 ¼	161 484 627	175 481 860
40-32	1 ¼	161 484 627	175 481 860
40-40	1 ¼	161 484 628	175 481 861
50-20	1 ½	161 484 627	161 484 634
50-25	1 ½	161 484 627	161 484 634
50-32	1 ½	161 484 627	161 484 634
50-40	1 ½	161 484 629	175 481 862
50-50	1 ½	161 484 629	175 481 862
63-20	2	161 484 627	161 484 634
63-25	2	161 484 627	161 484 634
63-32	2	161 484 627	161 484 634
63-40	2	161 484 630	175 481 863
63-50	2	161 484 630	175 481 863
63-63	2	161 484 630	175 481 863
75-40	2 ½	161 484 628	175 481 861
75-50	2 ½	161 484 630	175 481 863
75-63	2 ½	161 484 630	175 481 863
90-20	3	161 484 627	161 484 634
90-25	3	161 484 627	161 484 634
90-32	3	161 484 627	161 484 634
90-50	3	161 484 630	161 484 636
90-63	3	161 484 630	161 484 636
110-20	4	161 484 627	161 484 634
110-25	4	161 484 627	161 484 634
110-32	4	161 484 627	161 484 634
110-50	4	161 484 630	161 484 636
110-63	4	161 484 630	161 484 636



Diaphragm (2)

d [mm]	Inch	NBR Code	EPDM Code	FPM Code	PTFE/EPDM Code	PTFE/FPM Code
20-20		161 311 710	161 481 022	161 481 092	161 311 698	161 481 926
25-20		161 311 711	161 481 023	161 481 093	161 311 699	161 481 927
25-25		161 311 711	161 481 023	161 481 093	161 311 699	161 481 927
32-20		161 311 712	161 481 024	161 481 094	161 311 700	161 481 928
32-25		161 311 712	161 481 024	161 481 094	161 311 700	161 481 928
32-32		161 311 712	161 481 024	161 481 094	161 311 700	161 481 928
40-20		161 311 712	161 481 024	161 481 094	161 311 700	161 481 928
40-25		161 311 712	161 481 024	161 481 094	161 311 700	161 481 928
40-32		161 311 712	161 481 024	161 481 094	161 311 700	161 481 928
40-40		161 311 713	161 481 025	161 481 095	161 311 701	161 481 929
50-20		161 311 712	161 481 024	161 481 094	161 311 700	161 481 928
50-25		161 311 712	161 481 024	161 481 094	161 311 700	161 481 928
50-32		161 311 712	161 481 024	161 481 094	161 311 700	161 481 928
50-40		161 311 714	161 481 026	161 481 096	161 311 702	161 481 930
50-50		161 311 714	161 481 026	161 481 096	161 311 702	161 481 930
63-20		161 311 712	161 481 024	161 481 094	161 311 700	161 481 928
63-25		161 311 712	161 481 024	161 481 094	161 311 700	161 481 928
63-32		161 311 712	161 481 024	161 481 094	161 311 700	161 481 928
63-40		161 311 715	161 481 027	161 481 097	161 311 703	161 481 931
63-50		161 311 715	161 481 027	161 481 097	161 311 703	161 481 931
63-63		161 311 715	161 481 027	161 481 097	161 311 703	161 481 931
75-40		161 311 715	161 481 025	161 481 095	161 311 701	161 481 929
75-50		161 311 715	161 481 027	161 481 095	161 311 703	161 481 931
75-63		161 311 715	161 481 027	161 481 097	161 311 703	161 481 931
90-20		161 311 712	161 481 024	161 481 094	161 311 700	161 481 928
90-25		161 311 712	161 481 024	161 481 094	161 311 700	161 481 928
90-32		161 311 712	161 481 024	161 481 094	161 311 700	161 481 928
90-50		161 311 715	161 481 027	161 481 097	161 311 703	161 481 931
90-63		161 311 715	161 481 027	161 481 097	161 311 703	161 481 931
110-20		161 311 712	161 481 024	161 481 094	161 311 700	161 481 928
110-25		161 311 712	161 481 024	161 481 094	161 311 700	161 481 928
110-32		161 311 712	161 481 024	161 481 094	161 311 700	161 481 928
110-50		161 311 715	161 481 027	161 481 097	161 311 703	161 481 931
110-63		161 311 715	161 481 027	161 481 097	161 311 703	161 481 931

d [mm]	Inch	CSM Code	PTFE/EPDM SYGEF PLUS Code
20-20		161 311 728	161 484 452
25-20		161 311 729	161 484 453
25-25		161 311 729	161 484 453
32-20		161 311 730	161 484 454
32-25		161 311 730	161 484 454
32-32		161 311 730	161 484 454
40-20		161 311 730	161 484 454
40-25		161 311 730	161 484 454
40-32		161 311 730	161 484 454
40-40		161 311 731	161 484 455
50-20		161 311 730	161 484 454
50-25		161 311 730	161 484 454
50-32		161 311 730	161 484 454
50-40		161 311 732	161 484 456
50-50		161 311 732	161 484 456
63-20		161 311 730	161 484 454
63-25		161 311 730	161 484 454
63-32		161 311 730	161 484 454
63-40		161 311 733	161 484 457
63-50		161 311 733	161 484 457
63-63		161 311 733	161 484 457
75-40		161 311 731	161 484 455
75-50		161 311 733	161 484 457
75-63		161 311 733	161 484 457
90-20		161 311 730	161 484 454
90-25		161 311 730	161 484 454

table continued next page

d [mm]	Inch	CSM Code	PTFE/EPDM SYGEF PLUS Code
90-32		161 311 730	161 484 454
90-50		161 311 733	161 484 457
90-63		161 311 733	161 484 457
110-20		161 311 730	161 484 454
110-25		161 311 730	161 484 454
110-32		161 311 730	161 484 454
110-50		161 311 733	161 484 457
110-63		161 311 733	161 484 457

Pressure spindel (3)



d [mm]	Inch	elastomer di- aphragm Code	PTFE diaphragm Code
20-20	½	161 484 688	161 484 696
25-20	¾	161 484 689	161 484 697
25-25	¾	161 484 689	161 484 697
32-20	1	161 484 690	161 484 698
32-25	1	161 484 690	161 484 698
32-32	1	161 484 690	161 484 698
40-20	1 ¼	161 484 690	161 484 698
40-25	1 ¼	161 484 690	161 484 698
40-32	1 ¼	161 484 690	161 484 698
40-40	1 ¼	161 484 691	161 484 699
50-20	1 ½	161 484 690	161 484 698
50-25	1 ½	161 484 690	161 484 698
50-32	1 ½	161 484 690	161 484 698
50-40	1 ½	161 484 692	161 484 700
50-50	1 ½	161 484 692	161 484 700
63-20	2	161 484 690	161 484 698
63-25	2	161 484 690	161 484 698
63-32	2	161 484 690	161 484 698
63-40	2	161 484 693	161 484 701
63-50	2	161 484 693	161 484 701
63-63	2	161 484 693	161 484 701
75-40	2 ½	161 484 691	161 484 699
75-50	2 ½	161 484 693	161 484 701
75-63	2 ½	161 484 693	161 484 701
90-20	3	161 484 690	161 484 698
90-25	3	161 484 690	161 484 698
90-32	3	161 484 690	161 484 698
90-50	3	161 484 693	161 484 701
90-63	3	161 484 693	161 484 701
110-20	4	161 484 690	161 484 698
110-25	4	161 484 690	161 484 698
110-32	4	161 484 690	161 484 698
110-50	4	161 484 693	161 484 701
110-63	4	161 484 693	161 484 701

Fastening set (4)



d [mm]	Inch	Code
20-20	½	198 000 650
25-20	¾	198 000 651
25-25	¾	198 000 651
32-20	1	198 000 652
32-25	1	198 000 652
32-32	1	198 000 652
40-20	1 ¼	198 000 652
40-25	1 ¼	198 000 652
40-32	1 ¼	198 000 652
40-40	1 ¼	198 000 653
50-20	1 ½	198 000 652

table continued next page

d [mm]	Inch	Code
50-25	1 ½	198 000 652
50-32	1 ½	198 000 652
50-40	1 ½	198 000 654
50-50	1 ½	198 000 654
63-20	2	198 000 652
63-25	2	198 000 652
63-32	2	198 000 652
63-40	2	198 000 655
63-50	2	198 000 655
63-63	2	198 000 655
75-40	2 ½	198 000 653
75-50	2 ½	198 000 655
75-63	2 ½	198 000 655
90-20	3	198 000 652
90-25	3	198 000 652
90-32	3	198 000 652
90-50	3	198 000 655
90-63	3	198 000 655
110-20	4	198 000 652
110-25	4	198 000 652
110-32	4	198 000 652
110-50	4	198 000 655
110-63	4	198 000 655

Spare parts comprehensive

Connecting parts for ball valves 546/543/523

Check valves 561/562, ventilating & bleed valves 591/595

Solvent cement socket



d [mm]	Inch	DN [mm]	PVC-U metric (G01) Code	PVC-U BS (G04) Code	PVC-U ASTM (G03) Code	
16	3/8	10	161 490 666	161 490 734	161 490 712	
20	1/2	15	161 490 667	161 490 735	161 490 713	
25	3/4	20	161 490 668	161 490 736	161 490 714	
32	1	25	161 490 669	161 490 737	161 490 715	
40	1 1/4	32	161 490 670	161 490 738	161 490 716	
50	1 1/2	40	161 490 671	161 490 739	161 490 717	
63	2	50	161 490 672	161 490 740	161 490 718	
75	2 1/2	65	161 490 673	161 490 673	161 490 719	
90	3	80	161 490 674	161 490 742	161 490 720	
110	4	100	161 490 675	161 490 743	161 490 721	

d [mm]	Inch	DN [mm]	PVC-C metric (G11) Code	PVC-C ASTM (G13) Code	ABS metric (G20) Code	ABS BS (G21) Code
16	3/8	10	163 481 275	163 481 311	169 480 775	169 480 800
20	1/2	15	163 481 276	163 481 312	169 480 776	169 480 801
25	3/4	20	163 481 277	163 481 313	169 480 777	169 480 802
32	1	25	163 481 278	163 481 314	169 480 778	169 480 803
40	1 1/4	32	163 481 279	163 481 315	169 480 779	169 480 804
50	1 1/2	40	163 481 280	163 481 316	169 480 780	169 480 805
63	2	50	163 481 281	163 481 317	169 480 781	169 480 806
75	2 1/2	65	163 481 282	163 481 318	169 480 782	169 480 782
90	3	80	163 481 283	163 481 319	169 480 783	169 480 808
110	4	100	163 481 284	163 481 320	169 480 784	169 480 809

Solvent cement spigot



d [mm]	DN [mm]	PVC-U metric (G05) Code	PVC-C metric (G14) Code	
16	10	161 490 701	163 481 300	
20	15	161 490 702	163 481 301	
25	20	161 490 703	163 481 302	
32	25	161 490 704	163 481 303	
40	32	161 490 705	163 481 304	
50	40	161 490 706	163 481 305	
63	50	161 490 707	163 481 306	
75	65	161 490 708	163 481 307	
90	80	161 490 709	163 481 308	
110	100	161 490 710	163 481 309	

Threaded socket



Inch	DN [mm]	PVC-U Rp (G06) Code	PVC-U Rp rein- forced (G07) Code	PVC-U NPT (G09) Code	PVC-C Rp (G15) Code
3/8	10	161 490 690	161 490 825	161 490 723	163 481 286
1/2	15	161 490 691	161 490 826	161 490 724	163 481 287
3/4	20	161 490 692	161 490 827	161 490 725	163 481 288
1	25	161 490 693	161 490 828	161 490 726	163 481 289
1 1/4	32	161 490 694	161 490 829	161 490 727	163 481 290
1 1/2	40	161 490 695	161 490 830	161 490 728	163 481 291
2	50	161 490 696	161 490 831	161 490 729	163 481 292

table continued next page

Inch	DN [mm]	PVC-U Rp (G06) Code	PVC-U Rp rein- forced (G07) Code	PVC-U NPT (G09) Code	PVC-C Rp (G15) Code
2 ½	65	161 490 697		161 490 730	163 481 293
3	80	161 490 698		161 490 731	163 481 294
4	100	161 490 699		161 490 732	163 481 295

Inch	DN [mm]	PVC-C Rp rein- forced (G16) Code	PVC-C NPT (G17) Code	ABS Rp (G22) Code	ABS Rp rein- forced (G23) Code
¾	10	163 481 400	163 481 322	169 480 786	169 480 925
½	15	163 481 401	163 481 323	169 480 787	169 480 926
¾	20	163 481 402	163 481 324	169 480 788	169 480 927
1	25	163 481 403	163 481 325	169 480 789	169 480 928
1 ¼	32	163 481 404	163 481 326	169 480 790	169 480 929
1 ½	40	163 481 405	163 481 327	169 480 791	169 480 930
2	50	163 481 406	163 481 328	169 480 792	169 480 931
2 ½	65		163 481 329		
3	80		163 481 330		
4	100		163 481 331		

Inch	DN [mm]	PP-H Rp rein- forced (G33) Code	PP-H NPT rein- forced (G34) Code	PVDF NPT (G53) Code
¾	10	167 482 911	167 482 966	175 483 058
½	15	167 482 912	167 482 967	175 483 059
¾	20	167 482 913	167 482 968	175 483 060
1	25	167 482 914	167 482 969	175 483 061
1 ¼	32	167 482 915	167 482 970	175 483 062
1 ½	40	167 482 916	167 482 971	175 483 063
2	50	167 482 917	167 482 972	175 483 064
2 ½	65			
3	80			
4	100			

Fusion socket



d [mm]	DN [mm]	PP-H metric (G30) Code	PVDF metric (G50) Code	PE 100 metric (G40) Code
16	10	167 482 900	175 483 025	
20	15	167 482 901	175 483 026	193 480 176
25	20	167 482 902	175 483 027	193 480 177
32	25	167 482 903	175 483 028	193 480 178
40	32	167 482 904	175 483 029	193 480 179
50	40	167 482 905	175 483 030	193 480 180
63	50	167 482 906	175 483 031	193 480 181
75	65	167 482 907		
90	80	167 482 908		
110	100	167 482 909		

Socket fusion spigot IR-Plus®



d [mm]	DN [mm]	PP-H metric (G32) Code	PVDF metric (G51) Code
16	10	167 482 922	175 483 036
20	15	167 482 923	175 483 037
25	20	167 482 924	175 483 038
32	25	167 482 925	175 483 039
40	32	167 482 926	175 483 040
50	40	167 482 927	175 483 041
63	50	167 482 928	175 483 042
75	65	167 482 929	
90	80	167 482 930	
110	100	167 482 931	



Butt fusion spigot IR-Plus®

d [mm]	DN [mm]	PP-H metric SDR11 (G35) Code	PP-H metric SDR17,6 (G36) Code	PP-H metric long SDR11 (G37) Code	PP-N metric SDR11 Code
20	15	167 482 945		167 482 956	168 480 260
25	20	167 482 946		167 482 957	168 480 261
32	25	167 482 947		167 482 958	168 480 262
40	32	167 482 948		167 482 959	168 480 263
50	40	167 482 949	167 482 938	167 482 960	168 480 264
63	50	167 482 950	167 482 939	167 482 961	168 480 265
75	65	167 482 951	167 482 940		
90	80	167 482 952	167 482 941		
110	100	167 482 953	167 482 942		

d [mm]	DN [mm]	PVDF metric (G52) Code
20	15	175 483 048
25	20	175 483 049
32	25	175 483 050
40	32	175 483 051
50	40	175 483 052
63	50	175 483 053
75	65	
90	80	
110	100	



Butt fusion spigot PE100 IR-Plus®

d [mm]	DN [mm]	metric SDR11 (G41) Code	metric SDR17,6 (G42) Code	metric long SDR11 (G43) Code	metric long SDR17,6 (G44) Code
20	15	193 480 102		193 480 152	
25	20	193 480 103		193 480 153	
32	25	193 480 104		193 480 154	
40	32	193 480 105		193 480 155	
50	40	193 480 106	193 480 087	193 480 156	
63	50	193 480 107	193 480 088	193 480 157	
75	65			193 480 158	193 480 168
90	80			193 480 159	193 480 169
110	100			193 480 160	193 480 170



Fixed flange

d [mm]	DN [mm]	PVC-U metric (G60) Code	PP-H metric (G63) Code	PVDF metric (G64) Code
20	15	161 486 360	167 484 160	175 483 285
25	20	161 486 361	167 484 161	175 483 286
32	25	161 486 362	167 484 162	175 483 287
40	32	161 486 363	167 484 163	175 483 288
50	40	161 486 364	167 484 164	175 483 289
63	50	161 486 365	167 484 165	175 483 290



Backing flange

d [mm]	Inch	DN [mm]	PVC-U metric (G70) Code	PVC-U ANSI (G71) Code	PVC-U PP-St met- ric (G72) Code
20	½	15	161 486 265	161 486 275	161 486 285
25	¾	20	161 486 266	161 486 276	161 486 286
32	1	25	161 486 267	161 486 277	161 486 287
40	1 ¼	32	161 486 268	161 486 278	161 486 288
50	1 ½	40	161 486 269	161 486 279	161 486 289
63	2	50	161 486 270	161 486 280	161 486 290

table continued next page

d [mm]	Inch	DN [mm]	PVC-U metric (G70) Code	PVC-U ANSI (G71) Code	PVC-U PP-St met- ric (G72) Code	
75	2 ½	65	161 486 271	161 486 281	161 486 291	
90	3	80	161 486 272	161 486 282	161 486 292	
110	4	100	161 486 273	161 486 283	161 486 293	
d [mm]	Inch	DN [mm]	PVC-U PP-St ANSI (G73) Code	PVC-C PP-St met- ric (G72) Code	PVC-C PP-St ANSI (G73) Code	
20	½	15	161 486 425	163 481 412	163 481 425	
25	¾	20	161 486 426	163 481 413	163 481 426	
32	1	25	161 486 427	163 481 414	163 481 427	
40	1 ¼	32	161 486 428	163 481 415	163 481 428	
50	1 ½	40	161 486 429	163 481 416	163 481 429	
63	2	50	161 486 430	163 481 417	163 481 430	
75	2 ½	65	161 486 431	163 481 418	163 481 431	
90	3	80	161 486 432	163 481 419	163 481 432	
110	4	100	161 486 433	163 481 420	163 481 433	
d [mm]	Inch	DN [mm]	PP-H PP-St metric (G72) Code	PP-H PP-St ANSI (G73) Code		
20	½	15		167 484 065		
25	¾	20		167 484 066		
32	1	25		167 484 067		
40	1 ¼	32		167 484 068		
50	1 ½	40		167 484 069		
63	2	50		167 484 070		
75	2 ½	65	167 484 418	167 484 071		
90	3	80	167 484 419	167 484 072		
110	4	100	167 484 420	167 484 073		



Union nut

d [mm]	DN [mm]	PVC-U Code	PVC-C Code	ABS Code	PP-H Code	PVDF Code	
16	10	161 490 538	163 481 226	169 480 713	167 482 712	175 482 937	
20	15	161 490 538	163 481 226	169 480 713	167 482 712	175 482 937	
25	20	161 490 539	163 481 227	169 480 714	167 482 713	175 482 938	
32	25	161 490 540	163 481 228	169 480 715	167 482 714	175 482 939	
40	32	161 490 541	163 481 229	169 480 716	167 482 715	175 482 940	
50	40	161 490 542	163 481 230	169 480 717	167 482 716	175 482 941	
63	50	161 490 543	163 481 231	169 480 718	167 482 717	175 482 942	
75	65	161 490 544	163 481 232	169 480 719	167 482 718	175 482 943	
90	80	161 490 545	163 481 233	169 480 720	167 482 719	175 482 944	
110	100	161 490 546	163 481 234	169 480 721	167 482 720	175 482 945	

Spare parts line strainer

Spare parts line strainer type 305/306

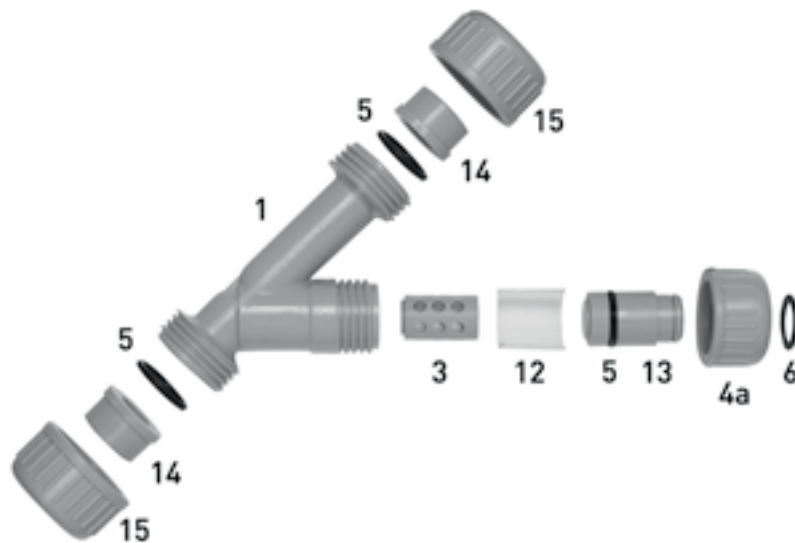

Screen set

Model:

- Screen set PVC-U and PVC-C DN15-DN50 consisting of: screen (3), screen support ring (2) and circlip (6), PVC-U DN65-DN80: screen (3) and screen support ring (2).
PP-H DN15-DN50: screen basket compl. with screen (3) and circlip (6)

d [mm]	Inch	DN [mm]	PVC-U Code	PP-H Code	PVC-C Code	
20	½	15	161 483 126	167 305 001	163 305 330	
25	¾	20	161 483 127	167 305 002	163 305 331	
32	1	25	161 483 128	167 305 003	163 305 332	
40	1 ¼	32	161 483 129	167 305 004	163 305 333	
50	1 ½	40	161 483 130	167 305 005	163 305 334	
63	2	50	161 483 131	167 305 006	163 305 335	
75	2 ½	65	161 483 132			
90	3	80	161 483 133			



Body (1)

d [mm]	Inch	DN [mm]	PVC-U transpar- ent Code	PVC-U transpar- ent ASTM Code	PVC-C Code	ABS Code	
20	½	15	192 300 301	192 480 001	163 481 075	169 480 600	
25	¾	20	192 300 351	192 480 002	163 481 076	169 480 601	
32	1	25	192 300 401	192 301 401	163 481 077	169 480 602	
40	1 ¼	32	192 300 451	192 301 451	163 481 078	169 480 603	
50	1 ½	40	192 300 501	192 301 501	163 481 079	169 480 604	
63	2	50	192 300 551	192 301 551	163 481 080	169 480 605	
75	2 ½	65	192 300 601				
90	3	80	192 300 651				

d [mm]	Inch	DN [mm]	PP-H Code	
20	½	15	167 305 010	
25	¾	20	167 305 011	
32	1	25	167 305 012	
40	1 ¼	32	167 305 013	
50	1 ½	40	167 305 014	
63	2	50	167 305 015	
75	2 ½	65		
90	3	80		



Screen cage (3)

Model:

- Screen cage in PVC-U, PVC-C and PP-H

d [mm]	Inch	DN [mm]	PVC-U Code	PVC-C Code	PP-H Code	
20	½	15	161 305 303	163 481 102	167 305 020	
25	¾	20	161 305 353	163 481 103	167 305 021	
32	1	25	161 305 403	163 481 104	167 305 022	
40	1 ¼	32	161 305 453	163 481 105	167 305 023	
50	1 ½	40	161 305 503	163 481 106	167 305 024	
63	2	50	161 305 553	163 481 107	167 305 025	
75	2 ½	65	161 305 603			
90	3	80	161 305 653			



Screen cage bracket (13)

Model:

- Only available for PP-H version

d [mm]	Inch	DN [mm]	PP-H Code	
20	½	15	167 305 040	
25	¾	20	167 305 041	
32	1	25	167 305 042	
40	1 ¼	32	167 305 043	
50	1 ½	40	167 305 044	
63	2	50	167 305 045	



Valve end metric (14)

Model:

- Only available for PP-H version

d [mm]	Inch	DN [mm]	fusion socket PP- H Code	butt fusion spigot IR PP-H SDR11 Code
20	½	15	727 600 106	727 508 506
25	¾	20	727 600 107	727 508 507
32	1	25	727 600 108	727 508 508

table continued next page

d [mm]	Inch	DN [mm]	fusion socket PP-H Code	butt fusion spigot IR PP-H SDR11 Code
40	1 ¼	32	727 600 109	727 508 509
50	1 ½	40	727 600 110	727 508 510
63	2	50	727 600 111	727 508 511



Valve nut (4a/15)

Model:

- Union nut PVC-U DN15-DN50, PP-H

d [mm]	Inch	DN [mm]	Cap nut PVC-U (4a) Code	Cap nut PVC-C (4a) Code	Cap nut ABS (4a) Code
20	½	15	161 300 308	163 481 084	169 480 609
25	¾	20	161 300 358	163 481 085	169 480 610
32	1	25	161 300 408	163 481 086	169 480 611
40	1 ¼	32	161 300 458	163 481 087	169 480 612
50	1 ½	40	161 300 508	163 481 088	169 480 613
63	2	50	161 300 558	163 481 089	169 480 614

d [mm]	Inch	DN [mm]	Cap nut PP-H (4a) Code	Connecting Nut PP-H (15) Code
20	½	15	167 305 060	167 305 070
25	¾	20	167 305 061	167 305 071
32	1	25	167 305 062	167 305 072
40	1 ¼	32	167 305 063	167 305 073
50	1 ½	40	167 305 064	167 305 074
63	2	50	167 305 065	167 305 075



Body seal (5)

Model:

- Body seal vor PVC-U and PP-H

d [mm]	Inch	DN [mm]	EPDM Code	FPM Code
20	½	15	748 410 006	749 410 006
25	¾	20	748 410 001	749 410 001
32	1	25	748 410 007	749 410 007
40	1 ¼	32	748 410 002	749 410 002
50	1 ½	40	748 410 003	749 410 003
63	2	50	748 410 012	749 410 012
75	2 ½	65	748 410 013	749 410 013
90	3	80	748 410 014	749 410 014



Screen perforation (7-11)

d [mm]	Inch	DN [mm]	PVC-U 0.5mm (7) Code	PVC-U 0.8mm (8) Code	PVC-U 1.4mm (9) Code
20	½	15	161 305 339	161 305 338	161 305 337
25	¾	20	161 305 389	161 305 388	161 305 387
32	1	25	161 305 439	161 305 438	161 305 437
40	1 ¼	32	161 305 489	161 305 488	161 305 487
50	1 ½	40	161 305 539	161 305 538	161 305 537
63	2	50	161 305 589	161 305 588	161 305 587
75	2 ½	65	161 305 639	161 305 638	161 305 637
90	3	80	161 305 689	161 305 688	161 305 687

table continued next page

d [mm]	Inch	DN [mm]	PVC-U 2.2mm (10) Code	PP-H (12) Code	stainless steel 0.5mm AISI 316 (11) Code
20	½	15	161 305 336	167 305 030	161 486 100
25	¾	20	161 305 386	167 305 031	161 486 101
32	1	25	161 305 436	167 305 032	161 486 102
40	1 ¼	32	161 305 486	167 305 033	161 486 103
50	1 ½	40	161 305 536	167 305 034	161 486 104
63	2	50	161 305 586	167 305 035	161 486 105
75	2 ½	65	161 305 636		161 486 106
90	3	80	161 305 686		161 486 107



Plug (4b)

Model:

- Only for PVC-U DN65-DN80

d [mm]	Inch	DN [mm]	PVC-U Code
75	2 ½	65	161 305 604
90	3	80	161 305 654



Circlip (6)

d [mm]	Inch	DN [mm]	PP-H Code	PVC-U Code
20	½	15	161 482 017	161 482 076
25	¾	20	161 482 018	161 482 017
32	1	25	161 482 019	161 482 018
40	1 ¼	32	161 482 020	161 482 019
50	1 ½	40	161 482 021	161 482 021
63	2	50	161 482 022	161 482 022

Spare parts cone check valves

Spare parts cone check valve type 561/562

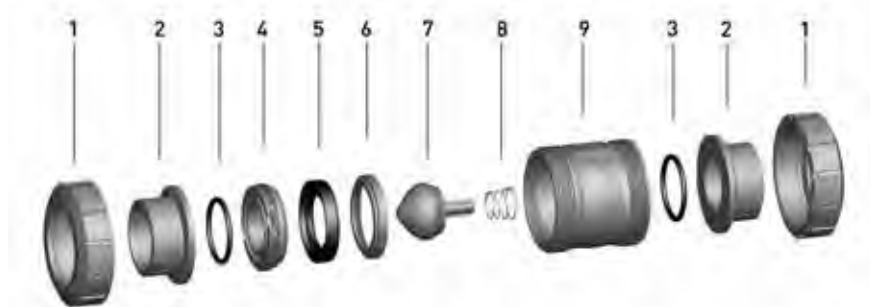

Central part without spring

Model:

- Central body consisting of: housing (9), union bush (4), support ring (6), cone (7), profile seal ring (5) and face seal (3)

d [mm]	Inch	DN [mm]	PVC-U EPDM Code	PVC-U FPM Code	PVC-C EPDM Code	PVC-C FPM Code	ABS EPDM Code
16	3/8	10	161 485 201	161 485 211	163 485 201	163 485 211	169 485 201
20	1/2	15	161 485 201	161 485 211	163 485 201	163 485 211	169 485 201
25	3/4	20	161 485 202	161 485 212	163 485 202	163 485 212	169 485 202
32	1	25	161 485 203	161 485 213	163 485 203	163 485 213	169 485 203
40	1 1/4	32	161 485 204	161 485 214	163 485 204	163 485 214	169 485 204
50	1 1/2	40	161 485 205	161 485 215	163 485 205	163 485 215	169 485 205
63	2	50	161 485 206	161 485 216	163 485 206	163 485 216	169 485 206
75	2 1/2	65	161 485 207	161 485 217	163 485 207	163 485 217	169 485 207
90	3	80	161 485 208	161 485 218	163 485 208	163 485 218	169 485 208
110	4	100	161 485 209	161 485 219	163 485 209	163 485 219	169 485 209

d [mm]	Inch	DN [mm]	PP-H EPDM Code	PP-H FPM Code	PVDF FPM Code
16	3/8	10	167 485 201	167 485 211	175 485 211
20	1/2	15	167 485 201	167 485 211	175 485 211
25	3/4	20	167 485 202	167 485 212	175 485 212
32	1	25	167 485 203	167 485 213	175 485 213
40	1 1/4	32	167 485 204	167 485 214	175 485 214
50	1 1/2	40	167 485 205	167 485 215	175 485 215
63	2	50	167 485 206	167 485 216	175 485 216
75	2 1/2	65	167 485 207	167 485 217	175 485 217
90	3	80	167 485 208	167 485 218	175 485 218
110	4	100	167 485 209	167 485 219	175 485 219



Central part with spring

Model:

- Central body consisting of: housing (9), union bush (4), support ring (6), cone (7), spring V2A (8), profile seal ring (5) and face seal (3)

d [mm]	Inch	DN [mm]	PVC-U EPDM Code	PVC-U FPM Code	PVC-C EPDM Code	PVC-C FPM Code	ABS EPDM Code
16	3/8	10	161 485 221	161 485 231	163 485 221	163 485 231	169 485 221
20	1/2	15	161 485 221	161 485 231	163 485 221	163 485 231	169 485 221
25	3/4	20	161 485 222	161 485 232	163 485 222	163 485 232	169 485 222
32	1	25	161 485 223	161 485 233	163 485 223	163 485 233	169 485 223
40	1 1/4	32	161 485 224	161 485 234	163 485 224	163 485 234	169 485 224
50	1 1/2	40	161 485 225	161 485 235	163 485 225	163 485 235	169 485 225
63	2	50	161 485 226	161 485 236	163 485 226	163 485 236	169 485 226

table continued next page

d [mm]	Inch	DN [mm]	PVC-U EPDM Code	PVC-U FPM Code	PVC-C EPDM Code	PVC-C FPM Code	ABS EPDM Code
75	2 ½	65	161 485 227	161 485 237	163 485 227	163 485 237	169 485 227
90	3	80	161 485 228	161 485 238	163 485 228	163 485 238	169 485 228
110	4	100	161 485 229	161 485 239	163 485 229	163 485 239	169 485 229

d [mm]	Inch	DN [mm]	PP-H EPDM Code	PP-H FPM Code	PVDF FPM Code
16	¾	10	167 485 231	167 485 241	175 485 231
20	½	15	167 485 231	167 485 241	175 485 231
25	¾	20	167 485 232	167 485 242	175 485 232
32	1	25	167 485 233	167 485 243	175 485 233
40	1 ¼	32	167 485 234	167 485 244	175 485 234
50	1 ½	40	167 485 235	167 485 245	175 485 235
63	2	50	167 485 236	167 485 246	175 485 236
75	2 ½	65	167 485 237	167 485 247	175 485 237
90	3	80	167 485 238	167 485 248	175 485 238
110	4	100	167 485 239	167 485 249	175 485 239



Cone (7)

d [mm]	Inch	DN [mm]	PVC-U Code	PVC-C Code	ABS Code	PP-H Code	PP-Talkum 20% Code
16	¾	10	161 491 151	163 482 151	169 482 151	167 485 151	167 485 351
20	½	15	161 491 151	163 482 151	169 482 151	167 485 151	167 485 351
25	¾	20	161 491 152	163 482 152	169 482 152	167 485 152	167 485 352
32	1	25	161 491 153	163 482 153	169 482 153	167 485 153	167 485 353
40	1 ¼	32	161 491 154	163 482 154	169 482 154	167 485 154	167 485 354
50	1 ½	40	161 491 155	163 482 155	169 482 155	167 485 155	167 485 355
63	2	50	161 491 156	163 482 156	169 482 156	167 485 156	167 485 356
75	2 ½	65	161 491 157	163 482 157	169 482 157	167 485 157	167 485 357
90	3	80	161 491 158	163 482 158	169 482 158	167 485 158	167 485 358
110	4	100	161 491 159	163 482 159	169 482 159	167 485 159	167 485 359

d [mm]	Inch	DN [mm]	PVDF Code
16	¾	10	175 484 151
20	½	15	175 484 151
25	¾	20	175 484 152
32	1	25	175 484 153
40	1 ¼	32	175 484 154
50	1 ½	40	175 484 155
63	2	50	175 484 156
75	2 ½	65	175 484 157
90	3	80	175 484 158
110	4	100	175 484 159



Profile seal ring (5)

d [mm]	Inch	DN [mm]	EPDM Code	FPM Code
16	¾	10	748 436 001	749 436 001
20	½	15	748 436 001	749 436 001
25	¾	20	748 436 002	749 436 002
32	1	25	748 436 003	749 436 003
40	1 ¼	32	748 436 004	749 436 004
50	1 ½	40	748 436 005	749 436 005
63	2	50	748 436 006	749 436 006
75	2 ½	65	748 436 007	749 436 007
90	3	80	748 436 008	749 436 008
110	4	100	748 436 009	749 436 009



Seal set

Model:

- Seal set consisting of: profile seal ring (5) and face seal (3)

d [mm]	Inch	DN [mm]	EPDM Code	FPM Code
16	3/8	10	161 485 241	161 485 251
20	1/2	15	161 485 241	161 485 251
25	3/4	20	161 485 242	161 485 252
32	1	25	161 485 243	161 485 253
40	1 1/4	32	161 485 244	161 485 254
50	1 1/2	40	161 485 245	161 485 255
63	2	50	161 485 246	161 485 256
75	2 1/2	65	161 485 247	161 485 257
90	3	80	161 485 248	161 485 258
110	4	100	161 485 249	161 485 259



Face seal (3)

d [mm]	Inch	DN [mm]	EPDM Code	FPM Code
16	3/8	10	748 410 059	749 410 059
20	1/2	15	748 410 059	749 410 059
25	3/4	20	748 410 106	749 410 106
32	1	25	748 410 151	749 410 151
40	1 1/4	32	748 410 062	749 410 062
50	1 1/2	40	748 410 003	749 410 003
63	2	50	748 410 231	749 410 231
75	2 1/2	65	748 410 119	749 410 119
90	3	80	748 410 023	749 410 023
110	4	100	748 410 254	749 410 254



Spring (8)

Model:

- Material: V2A, code: 1.4310
- Material: NIMONIC 90, code: 2.4632
- Material: V2A, code: 1.4310, HALAR® coated

d [mm]	Inch	DN [mm]	Stainless steel V2A Code	V2A HALAR coat- ed Code	NIMONIC 90 Code
16	3/8	10	161 485 132	161 485 142	161 485 152
20	1/2	15	161 485 132	161 485 142	161 485 152
25	3/4	20	161 485 132	161 485 142	161 485 152
32	1	25	161 485 133	161 485 143	161 485 153
40	1 1/4	32	161 485 134	161 485 144	161 485 154
50	1 1/2	40	161 485 135	161 485 145	161 485 155
63	2	50	161 485 136	161 485 146	161 485 156
75	2 1/2	65	161 485 137	161 485 147	161 485 157
90	3	80	161 485 138	161 485 148	161 485 158
110	4	100	161 485 139	161 485 149	161 485 159



Handle for dismantling

d [mm]	Inch	DN [mm]	red Code	black Code
16	3/8	10	167 484 088	167 484 076
20	1/2	15	167 484 088	167 484 076
25	3/4	20	167 484 089	167 484 077
32	1	25	167 484 090	167 484 078
40	1 1/4	32	167 484 091	167 484 079
50	1 1/2	40	167 484 092	167 484 080
63	2	50	167 484 093	167 484 081
75	2 1/2	65	167 484 094	167 484 082
90	3	80	167 484 095	167 484 083
110	4	100	167 484 096	167 484 084

Spare parts ball check valves

Spare parts ball check valve type 360

DN 10-50

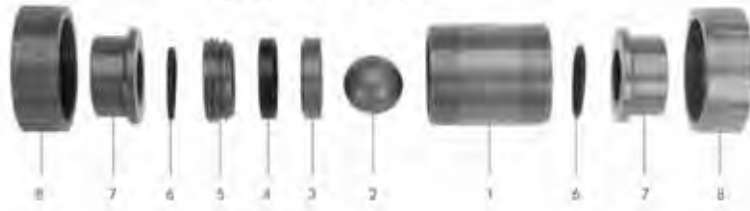

DN 80

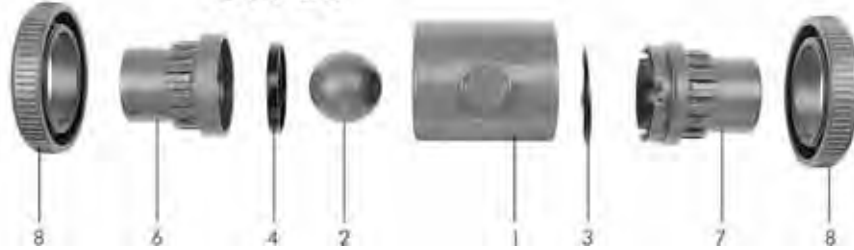

Central part

Model:

- Central part consisting of: body (1), ball (2), support ring (3), sealing ring (4) and union bush (5)

d [mm]	Inch	DN [mm]	PVC-U EPDM Code	PVC-U FPM Code	PVC-C EPDM Code	PVC-C FPM Code	ABS EPDM Code
16	3/8	10	161 483 851	161 483 861	163 480 645	163 480 655	169 480 250
20	1/2	15	161 483 852	161 483 862	163 480 646	163 480 656	169 480 251
25	3/4	20	161 483 853	161 483 863	163 480 647	163 480 657	169 480 252
32	1	25	161 483 854	161 483 864	163 480 648	163 480 658	169 480 253
40	1 1/4	32	161 483 855	161 483 865	163 480 649	163 480 659	169 480 254
50	1 1/2	40	161 483 856	161 483 866	163 480 650	163 480 660	169 480 255
63	2	50	161 483 857	161 483 867	163 480 651	163 480 661	169 480 256

d [mm]	Inch	DN [mm]	PP-H EPDM Code	PP-H FPM Code
16	3/8	10	167 481 125	167 481 135
20	1/2	15	167 481 126	167 481 136
25	3/4	20	167 481 127	167 481 137
32	1	25	167 481 128	167 481 138
40	1 1/4	32	167 481 129	167 481 139
50	1 1/2	40	167 481 130	167 481 140
63	2	50	167 481 131	167 481 141

Ball (2)



d [mm]	Inch	DN [mm]	PVC-U Code	PP-H with talc density 1.24 Code	PP-H 100% Code	PVDF Code
16	3/8	10	161 330 304	167 481 165	167 480 024	175 480 153
20	1/2	15	161 330 304	167 481 165	167 480 024	175 480 153
25	3/4	20	161 330 354	167 481 166	167 480 025	175 480 154
32	1	25	161 330 404	167 481 167	167 480 026	175 480 155
40	1 1/4	32	161 330 454	167 481 168	167 480 027	175 480 156
50	1 1/2	40	161 330 504	167 481 169	167 480 028	175 480 157
63	2	50	161 330 554	167 481 170	167 480 029	175 480 158
90	3	80	161 330 654			

Sealing ring (4)



d [mm]	Inch	DN [mm]	EPDM Code	FPM Code
16	3/8	10	161 483 259	161 483 265
20	1/2	15	161 483 259	161 483 265
25	3/4	20	161 483 260	161 483 266
32	1	25	161 483 261	161 483 267
40	1 1/4	32	161 483 262	161 483 268
50	1 1/2	40	161 483 263	161 483 269
63	2	50	161 483 264	161 483 270
90	3	80	161 480 141	161 480 149

Face seal (6)



d [mm]	Inch	DN [mm]	EPDM Code	FPM Code
16	3/8	10	748 410 042	749 410 042
20	1/2	15	748 410 042	749 410 042
25	3/4	20	748 410 116	749 410 116
32	1	25	748 410 103	749 410 103
40	1 1/4	32	748 410 027	749 410 027
50	1 1/2	40	748 410 010	749 410 010
63	2	50	748 410 011	749 410 011
90	3	80	748 410 099	749 410 099

Union nut (8)



d [mm]	Inch	DN [mm]	PVC-U Code	PVC-C Code	ABS Code	PP-H Code	PVDF Code
16	3/8	10	161 340 617	163 480 995	169 480 101	167 480 786	175 480 819
20	1/2	15	161 340 617	163 480 995	169 480 101	167 480 786	175 480 819
25	3/4	20	161 340 618	163 480 081	169 480 102	167 480 787	175 480 820
32	1	25	161 340 619	163 480 082	169 480 103	167 480 788	175 480 821
40	1 1/4	32	161 340 620	163 480 083	169 480 104	167 480 789	175 480 822
50	1 1/2	40	161 340 621	163 480 084	169 480 105	167 480 790	175 480 823
63	2	50	161 480 522	163 480 085	169 480 106	167 480 791	175 480 824
90	3	80	161 340 623				

Valve end with socket (7)



d [mm]	Inch	DN [mm]	PVC-U metric Code	PVC-U JIS Code	PVC-U ANSI Code	PVC-U BS Code	PVC-C metric Code
16	3/8	10	161 480 536	161 484 601	161 482 377	161 480 543	163 480 522
20	1/2	15	161 480 537	161 484 602	-	161 480 544	163 480 523
25	3/4	20	161 480 538	161 484 603	161 482 379	161 480 545	163 480 524
32	1	25	161 480 539	161 484 604	161 482 380	161 480 546	163 480 525
40	1 1/4	32	161 480 540	161 484 605	161 482 381	161 480 547	163 480 526
50	1 1/2	40	161 480 541	161 484 606	161 482 382	161 480 548	163 480 527
63	2	50	161 480 542		161 482 383	161 480 549	163 480 528

d [mm]	Inch	DN [mm]	ABS metric Code	PE80 metric Code	PP-H metric Code	PP-H ANSI Code	PVDF metric Code
16	3/8	10	169 480 152	173 480 000	167 480 159	167 480 452	175 480 031
20	1/2	15	169 480 153	173 480 001	167 480 160	167 480 453	175 480 032
25	3/4	20	169 480 154	173 480 002	167 480 161	167 480 454	175 480 033
32	1	25	169 480 155	173 480 003	167 480 162	167 480 455	175 480 034
40	1 1/4	32	169 480 156	173 480 004	167 480 163	167 480 456	175 480 035
50	1 1/2	40	169 480 157	173 480 005	167 480 164	167 480 457	175 480 036
63	2	50	169 480 158	173 480 006	167 480 165	167 480 458	175 480 037



Valve end with spigot (7)

d [mm]	Inch	DN [mm]	PVC-U metric Code	PVC-U metric in- let and outlet Code	PP-H metric Code	PP-H SDR11 long Code
16	3/8	10	161 482 345		167 480 527	-
20	1/2	15	161 482 346		167 480 528	167 482 546
25	3/4	20	161 482 347		167 480 529	167 482 547
32	1	25	161 482 348		167 480 530	167 482 548
40	1 1/4	32	161 482 349		167 480 531	167 482 549
50	1 1/2	40	161 482 350		167 480 532	167 482 550
63	2	50	161 482 351		167 480 533	167 482 551
90	3	80		161 480 132		
90	3	80		161 480 133		

d [mm]	Inch	DN [mm]	PP-H SDR11 IR Code	PP-H SDR17 Code	PVDF metric Code	PVDF metric Code
16	3/8	10	-	-	175 480 787	175 480 796
20	1/2	15	167 480 546	167 480 537	175 480 788	175 480 797
25	3/4	20	167 480 547	167 480 538	175 480 789	175 480 798
32	1	25	167 480 548	167 480 539	175 480 790	175 480 799
40	1 1/4	32	167 480 549	167 480 540	175 480 791	175 480 800
50	1 1/2	40	167 480 550	167 480 541	175 480 792	175 480 801
63	2	50	167 480 551	167 480 542	175 480 793	175 480 802
90	3	80				
90	3	80				

d [mm]	Inch	DN [mm]	PE100 SDR11 Code	PE100 SDR11 long Code	PE100 SDR17,6 Code
16	3/8	10	193 480 026		
20	1/2	15	193 480 027	193 480 127	
25	3/4	20	193 480 028	193 480 128	193 480 014
32	1	25	193 480 029	193 480 129	193 480 015
40	1 1/4	32	193 480 030	193 480 130	193 480 016
50	1 1/2	40	193 480 031	193 480 131	193 480 017
63	2	50	193 480 032	193 480 132	193 480 018
90	3	80			
90	3	80			



Threaded bush (7)

Inch	DN [mm]	PVC-U Rp Code	PVC-U Rc Code	PVC-U NPT Code	PP-H Rp Code	PP-H NPT Code
3/8	10	161 480 550	-	161 482 389	167 480 166	167 480 452
1/2	15	161 480 551	161 484 610	-	167 480 167	167 480 453
3/4	20	161 480 552	161 484 611	161 482 391	167 480 168	167 480 454
1	25	161 480 553	161 484 612	161 482 392	167 480 169	167 480 455
1 1/4	32	161 480 554	161 484 613	161 482 393	167 480 170	167 480 456
1 1/2	40	161 480 555	161 484 614	161 482 394	167 480 171	167 480 457
2	50	161 480 556		161 482 395	167 480 172	167 480 458

Inch	DN [mm]	PVDF NPT Code
3/8	10	175 480 727
1/2	15	175 480 728
3/4	20	175 480 729
1	25	175 480 730
1 1/4	32	175 480 731
1 1/2	40	175 480 732
2	50	175 480 733

Fixed flange jointing face serrated metric



d [mm]	Inch	DN [mm]	PP-H Code	PVDF Code
20	1/2	15	727 740 106	735 740 106
25	3/4	20	727 740 107	735 740 107
32	1	25	727 740 108	735 740 108
40	1 1/4	32	727 740 109	735 740 109
50	1 1/2	40	727 740 110	735 740 110
63	2	50	727 740 111	735 740 111

Seal set (4, 6)



d [mm]	Inch	DN [mm]	EPDM Code	FPM Code
16	3/8	10	161 482 910	161 482 920
20	1/2	15	161 482 910	161 482 920
25	3/4	20	161 482 911	161 482 921
32	1	25	161 482 912	161 482 922
40	1 1/4	32	161 482 913	161 482 923
50	1 1/2	40	161 482 914	161 482 924
63	2	50	161 482 915	161 482 925

Body (1)



d [mm]	Inch	DN [mm]	PVC-U Code
90	3	80	161 480 158

Spare parts ventilating- and bleed valves

Spare parts ventilating- and bleed valve type 591/595

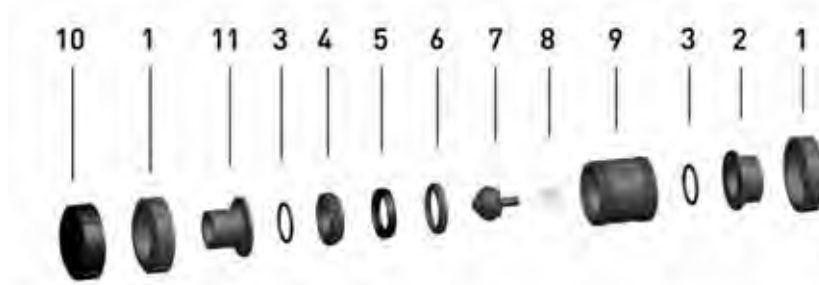

Central part without spring

Model:

- Central body consisting of: housing (9), union bush (4), support ring (6), floater PP-H/ PVDF (7), profile seal ring (5) and face seal (3)

d [mm]	Inch	DN [mm]	PVC-U EPDM Code	PVC-U FPM Code	PVC-C EPDM Code	PVC-C FPM Code	ABS EPDM Code
16	3/8	10	161 485 261	161 485 271	163 485 261	163 485 271	169 485 261
20	1/2	15	161 485 261	161 485 271	163 485 261	163 485 271	169 485 261
25	3/4	20	161 485 262	161 485 272	163 485 262	163 485 272	169 485 262
32	1	25	161 485 263	161 485 273	163 485 263	163 485 273	169 485 263
40	1 1/4	32	161 485 264	161 485 274	163 485 264	163 485 274	169 485 264
50	1 1/2	40	161 485 265	161 485 275	163 485 265	163 485 275	169 485 265
63	2	50	161 485 266	161 485 276	163 485 266	163 485 276	169 485 266
75	2 1/2	65	161 485 267	161 485 277	163 485 267	163 485 277	169 485 267
90	3	80	161 485 268	161 485 278	163 485 268	163 485 278	169 485 268
110	4	100	161 485 269	161 485 279	163 485 269	163 485 279	169 485 269

d [mm]	Inch	DN [mm]	PP-H EPDM Code	PP-H FPM Code	PVDF FPM Code
16	3/8	10	167 485 261	167 485 271	175 485 271
20	1/2	15	167 485 261	167 485 271	175 485 271
25	3/4	20	167 485 262	167 485 272	175 485 272
32	1	25	167 485 263	167 485 273	175 485 273
40	1 1/4	32	167 485 264	167 485 274	175 485 274
50	1 1/2	40	167 485 265	167 485 275	175 485 275
63	2	50	167 485 266	167 485 276	175 485 276
75	2 1/2	65	167 485 267	167 485 277	175 485 277
90	3	80	167 485 268	167 485 278	175 485 278
110	4	100	167 485 269	167 485 279	175 485 279

Central part with spring

Model:

- Central body consisting of: housing (9), union bush (4), support ring (6), floater (7), spring Nimonic 90 Halar coated (8), profile seal ring (5) and face seal (3)

d [mm]	Inch	DN [mm]	PVC-U EPDM Code	PVC-U FPM Code	PVC-C EPDM Code	PVC-C FPM Code	ABS EPDM Code
16	3/8	10	161 485 281	161 485 291	163 485 281	163 485 291	169 485 281
20	1/2	15	161 485 281	161 485 291	163 485 281	163 485 291	169 485 281
25	3/4	20	161 485 282	161 485 292	163 485 282	163 485 292	169 485 282
32	1	25	161 485 283	161 485 293	163 485 283	163 485 293	169 485 283
40	1 1/4	32	161 485 284	161 485 294	163 485 284	163 485 294	169 485 284
50	1 1/2	40	161 485 285	161 485 295	163 485 285	163 485 295	169 485 285
63	2	50	161 485 286	161 485 296	163 485 286	163 485 296	169 485 286
75	2 1/2	65	161 485 287	161 485 297	163 485 287	163 485 297	169 485 287
90	3	80	161 485 288	161 485 298	163 485 288	163 485 298	169 485 288
110	4	100	161 485 289	161 485 299	163 485 289	163 485 299	169 485 289

table continued next page

d [mm]	Inch	DN [mm]	PP-H EPDM Code	PP-H FPM Code	PVDF FPM Code
16	3/8	10	167 485 281	167 485 291	175 485 291
20	1/2	15	167 485 281	167 485 291	175 485 291
25	3/4	20	167 485 282	167 485 292	175 485 292
32	1	25	167 485 283	167 485 293	175 485 293
40	1 1/4	32	167 485 284	167 485 294	175 485 294
50	1 1/2	40	167 485 285	167 485 295	175 485 295
63	2	50	167 485 286	167 485 296	175 485 296
75	2 1/2	65	167 485 287	167 485 297	175 485 297
90	3	80	167 485 288	167 485 298	175 485 298
110	4	100	167 485 289	167 485 299	175 485 299

Cone (7)

Model:

- For type 595



d [mm]	Inch	DN [mm]	PVC-U Code	PVC-C Code	ABS Code	PP-H Code	PVDF Code
16	3/8	10	161 491 151	163 482 151	169 482 151	167 485 151	175 484 151
20	1/2	15	161 491 151	163 482 151	169 482 151	167 485 151	175 484 151
25	3/4	20	161 491 152	163 482 152	169 482 152	167 485 152	175 484 152
32	1	25	161 491 153	163 482 153	169 482 153	167 485 153	175 484 153
40	1 1/4	32	161 491 154	163 482 154	169 482 154	167 485 154	175 484 154
50	1 1/2	40	161 491 155	163 482 155	169 482 155	167 485 155	175 484 155
63	2	50	161 491 156	163 482 156	169 482 156	167 485 156	175 484 156
75	2 1/2	65	161 491 157	163 482 157	169 482 157	167 485 157	175 484 157
90	3	80	161 491 158	163 482 158	169 482 158	167 485 158	175 484 158
110	4	100	161 491 159	163 482 159	169 482 159	167 485 159	175 484 159

Floater (7)

Model:

- For type 591



d [mm]	Inch	DN [mm]	PP-H Code	PVDF Code
16	3/8	10	167 485 151	175 484 161
20	1/2	15	167 485 151	175 484 161
25	3/4	20	167 485 152	175 484 162
32	1	25	167 485 153	175 484 163
40	1 1/4	32	167 485 154	175 484 164
50	1 1/2	40	167 485 155	175 484 165
63	2	50	167 485 156	175 484 166
75	2 1/2	65	167 485 157	175 484 167
90	3	80	167 485 158	175 484 168
110	4	100	167 485 159	175 484 169

Profile seal ring (5)

d [mm]	Inch	DN [mm]	EPDM Code	FPM Code
16	3/8	10	748 436 001	749 436 001
20	1/2	15	748 436 001	749 436 001
25	3/4	20	748 436 002	749 436 002
32	1	25	748 436 003	749 436 003
40	1 1/4	32	748 436 004	749 436 004
50	1 1/2	40	748 436 005	749 436 005
63	2	50	748 436 006	749 436 006
75	2 1/2	65	748 436 007	749 436 007
90	3	80	748 436 008	749 436 008
110	4	100	748 436 009	749 436 009



Protective cap (10)

Model:

- Protects the piping system from dirt particles out of the ambient air
Can also be used as tool for opening and closing the valve union bushing

d [mm]	Inch	DN [mm]	PP-GF Code
16	3/8	10	167 485 361
20	1/2	15	167 485 361
25	3/4	20	167 485 362
32	1	25	167 485 363
40	1 1/4	32	167 485 364
50	1 1/2	40	167 485 365
63	2	50	167 485 366



Seal set

Model:

- Seal set consisting of: profile seal ring (5) and face seal (3)

d [mm]	Inch	DN [mm]	EPDM Code	FPM Code
16	3/8	10	161 485 241	161 485 251
20	1/2	15	161 485 241	161 485 251
25	3/4	20	161 485 242	161 485 252
32	1	25	161 485 243	161 485 253
40	1 1/4	32	161 485 244	161 485 254
50	1 1/2	40	161 485 245	161 485 255
63	2	50	161 485 246	161 485 256
75	2 1/2	65	161 485 247	161 485 257
90	3	80	161 485 248	161 485 258
110	4	100	161 485 249	161 485 259



Face seal (3)

d [mm]	Inch	DN [mm]	EPDM Code	FPM Code
16	3/8	10	748 410 059	749 410 059
20	1/2	15	748 410 059	749 410 059
25	3/4	20	748 410 106	749 410 106
32	1	25	748 410 151	749 410 151
40	1 1/4	32	748 410 062	749 410 062
50	1 1/2	40	748 410 003	749 410 003
63	2	50	748 410 231	749 410 231
75	2 1/2	65	748 410 119	749 410 119
90	3	80	748 410 023	749 410 023
110	4	100	748 410 254	749 410 254



Spring (8)

Model:

- Material: V2A, code: 1.4310, HALAR® coated

d [mm]	Inch	DN [mm]	NIMONIC 90 HALAR coated Code
16	3/8	10	161 485 112
20	1/2	15	161 485 112
25	3/4	20	161 485 112
32	1	25	161 485 113
40	1 1/4	32	161 485 114
50	1 1/2	40	161 485 115
63	2	50	161 485 116
75	2 1/2	65	161 485 117
90	3	80	161 485 118
110	4	100	161 485 119



Handle for dismantling

d [mm]	Inch	DN [mm]	red Code	black Code
16	$\frac{3}{8}$	10	167 484 088	167 484 076
20	$\frac{1}{2}$	15	167 484 088	167 484 076
25	$\frac{3}{4}$	20	167 484 089	167 484 077
32	1	25	167 484 090	167 484 078
40	1 $\frac{1}{4}$	32	167 484 091	167 484 079
50	1 $\frac{1}{2}$	40	167 484 092	167 484 080
63	2	50	167 484 093	167 484 081
75	2 $\frac{1}{2}$	65	167 484 094	167 484 082
90	3	80	167 484 095	167 484 083
110	4	100	167 484 096	167 484 084

Spare parts wafer check valves

Spare parts wafer check valve type 369

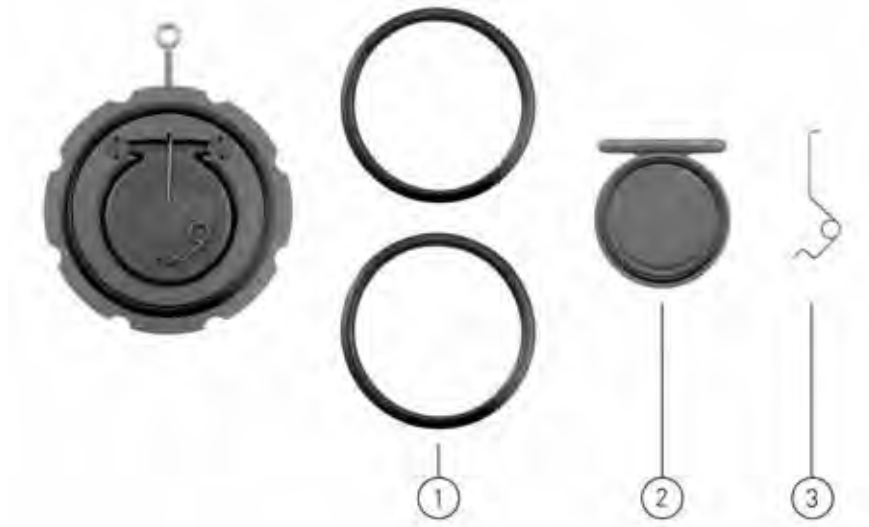

Seal set (1)



d [mm]	Inch	DN [mm]	EPDM Code	FPM Code
40	1 ¼	32	161 484 875	161 484 887
50	1 ½	40	161 484 876	161 484 888
63	2	50	161 484 877	161 484 889
75	2 ½	65	161 484 878	161 484 890
90	3	80	161 484 879	161 484 891
110	4	100	161 484 880	161 484 892
140	5	125	161 484 881	161 484 893
160	6	150	161 484 882	161 484 894
225	8	200	161 484 883	161 484 895
280	10	250	161 484 884	161 484 896
315	12	300	161 484 885	161 484 897

Disc set (2)



d [mm]	Inch	DN [mm]	PVC-U EPDM Code	PVC-U FPM Code	PP-H EPDM Code	PP-H FPM Code	PVDF FPM Code
40	1 ¼	32	161 369 122	161 369 142	167 369 122	167 369 142	175 369 142
50	1 ½	40	161 369 123	161 369 143	167 369 123	167 369 143	175 369 143
63	2	50	161 369 124	161 369 144	167 369 124	167 369 144	175 369 144
75	2 ½	65	161 369 125	161 369 145	167 369 125	167 369 145	175 369 145
90	3	80	161 369 126	161 369 146	167 369 126	167 369 146	175 369 146
110	4	100	161 369 127	161 369 147	167 369 127	167 369 147	175 369 147
140	5	125	161 369 128	161 369 148	167 369 128	167 369 148	175 369 148
160	6	150	161 369 129	161 369 149	167 369 129	167 369 149	175 369 149
225	8	200	161 369 130	161 369 150	167 369 130	167 369 150	175 369 150
280	10	250	161 369 131	161 369 151	167 369 131	167 369 151	175 369 151
315	12	300	161 369 132	161 369 152	167 369 132	167 369 152	175 369 152

Spring (3)



d [mm]	Inch	DN [mm]	V4A Code	Hastelloy C Code
40	1 ¼	32	161 484 900	161 484 912
50	1 ½	40	161 484 901	161 484 913
63	2	50	161 484 902	161 484 914
75	2 ½	65	161 484 903	161 484 915
90	3	80	161 484 904	161 484 916
110	4	100	161 484 905	161 484 917
140	5	125	161 484 905	161 484 917

table continued next page

d [mm]	Inch	DN [mm]	V4A Code	Hastelloy C Code	
160	6	150	161 484 907	161 484 919	
225	8	200	161 484 908	161 484 920	
280	10	250	161 484 909	161 484 921	
315	12	300	161 484 910	161 484 922	

Spare parts solenoid valves

Spare parts solenoid valve type 157

coil set

Voltage	Function	EPDM Code	FPM Code
24V DC	A	198 808 000	198 808 006
24V DC	B	198 808 001	198 808 007
24V UC	A	198 808 002	198 808 008
24V UC	B	198 808 003	198 808 009
230V AC	A	198 808 004	198 808 010
230V AC	B	198 808 005	198 808 011

wear part set

	EPDM Code	FPM Code
e.g. diaphragm	198 808 012	198 808 013

Spare parts solenoid valve type 160/161

coil set

24V UC Code	230 V UC Code	230 V/ 50Hz Code
198 808 014	198 808 015	198 808 016

spare part kit

Function	UC Code	50Hz Code
A	198 808 017	198 808 021
B	198 808 018	-
E	198 808 019	-
F	198 808 020	198 808 022

wear part set

d [mm]	DN [mm]	EPDM Code	FPM Code
16	10	198 808 023	198 808 026
20	15	198 808 024	198 808 027
25	20	198 808 025	198 808 028

Spare parts solenoid valve type 165

coil set

Voltage	EPDM Code	FPM Code
24V DC	198 808 029	198 808 032
230V AC	198 808 030	198 808 033
110V AC	198 808 031	198 808 034

wear part set

d-d [mm]	DN-DN [mm]	EPDM Code	FPM Code
20 - 25	15 - 20	198 808 035	198 808 038
32 - 40	25 - 32	198 808 036	198 808 039
50 - 63	40 - 50	198 808 037	198 808 040

Spare parts solenoid valve type 166 coil set

Voltage	Function	EPDM Code	FPM Code
24V DC	A	198 808 041	198 808 047
230V AC	A	198 808 042	198 808 048
24V DC	C	198 808 043	-
24V UC	C	-	198 808 049
230V AC	C	198 808 044	198 808 050
24V DC	E	198 808 045	198 808 051
230V AC	E	198 808 046	198 808 052

wear part set

	EPDM Code	FPM Code
e.g. diaphragm	198 808 053	198 808 054

Spare parts variable area flow meters

Variable area flow meter type 335

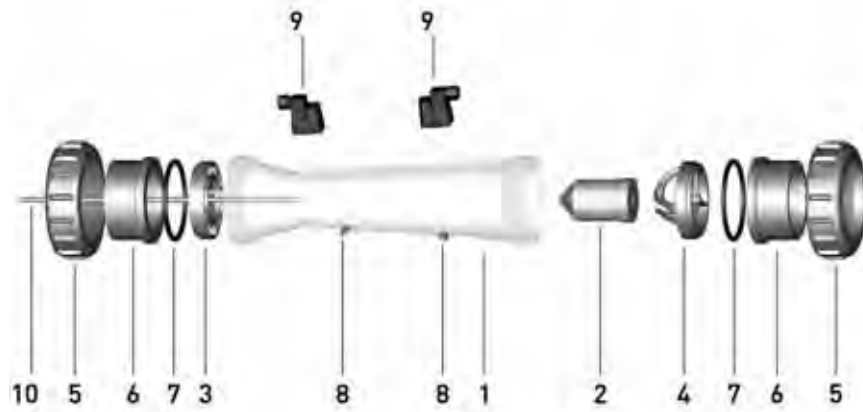

Taper tube with water scale (1)

- PVC-U transparent



Scale range [l/h]	d [mm]	Inch	DN [mm]	PVC-U transpar- ent Code	Polyamid Code	Polysulfon Code
50 - 500	32	1	25	198 335 055	198 335 070	198 335 085
100 - 1000	32	1	25	198 335 056	198 335 071	198 335 086
150 - 1500	40	1 ¼	32	198 335 057	198 335 072	198 335 087
250 - 2500	40	1 ¼	32	198 335 058	198 335 073	198 335 088
200 - 2000	50	1 ½	40	198 335 059	198 335 074	198 335 089
300 - 3000	50	1 ½	40	198 335 060	198 335 075	198 335 090
600 - 6000	50	1 ½	40	198 335 061	198 335 076	198 335 091
600 - 6000	63	2	50	198 335 062	198 335 077	198 335 092
1000 - 10000	63	2	50	198 335 063	198 335 078	198 335 093
1500 - 15000	63	2	50	198 335 064	198 335 079	198 335 094
2000 - 20000	75	2 ½	65	198 335 065	198 335 080	198 335 095
3000 - 30000	75	2 ½	65	198 335 066	198 335 081	198 335 096
8000 - 60000	75	2 ½	65	198 335 067	198 335 082	198 335 097

Taper tube without scale (1)



Scale range [l/h]	d [mm]	Inch	DN [mm]	PVC-U transpar- ent Code	Polyamid Code	Polysulfon Code
50 - 500	32	1	25	198 335 255	198 335 270	198 335 285
100 - 1000	32	1	25	198 335 256	198 335 271	198 335 286
150 - 1500	40	1 ¼	32	198 335 257	198 335 272	198 335 287
250 - 2500	40	1 ¼	32	198 335 258	198 335 273	198 335 288
200 - 2000	50	1 ½	40	198 335 259	198 335 274	198 335 289
300 - 3000	50	1 ½	40	198 335 260	198 335 275	198 335 290
600 - 6000	50	1 ½	40	198 335 261	198 335 276	198 335 291
600 - 6000	63	2	50	198 335 262	198 335 277	198 335 292
1000 - 10000	63	2	50	198 335 263	198 335 278	198 335 293
1500 - 15000	63	2	50	198 335 264	198 335 279	198 335 294
2000 - 20000	75	2 ½	65	198 335 265	198 335 280	198 335 295
3000 - 30000	75	2 ½	65	198 335 266	198 335 281	198 335 296
8000 - 60000	75	2 ½	65	198 335 267	198 335 282	198 335 297



Insert PVDF (3,4)

Scale range [l/h]	d [mm]	Inch	DN [mm]	top (4) Code	bottom (3) Code	bottom (3) for PEEK guiding rod Code
50 - 500	32	1	25	198 335 970	198 335 977	
100 - 1000	32	1	25	198 335 970	198 335 977	
150 - 1500	40	1 ¼	32	198 335 971	198 335 978	
250 - 2500	40	1 ¼	32	198 335 971	198 335 978	
200 - 2000	50	1 ½	40	198 335 972	198 335 979	
300 - 3000	50	1 ½	40	198 335 972	198 335 979	
600 - 6000	50	1 ½	40	198 335 972	198 335 979	
600 - 6000	63	2	50	198 335 973	198 335 980	
1000 - 10000	63	2	50	198 335 973	198 335 980	
1500 - 15000	63	2	50	198 335 974		198 335 982
2000 - 20000	75	2 ½	65	198 335 975		198 335 981
3000 - 30000	75	2 ½	65	198 335 975		198 335 981
8000 - 60000	75	2 ½	65	198 335 975		198 335 981

Scale range [l/h]	d [mm]	Inch	DN [mm]	bottom (3) for PVDF/SS guiding rod Code
50 - 500	32	1	25	
100 - 1000	32	1	25	
150 - 1500	40	1 ¼	32	
250 - 2500	40	1 ¼	32	
200 - 2000	50	1 ½	40	
300 - 3000	50	1 ½	40	
600 - 6000	50	1 ½	40	
600 - 6000	63	2	50	
1000 - 10000	63	2	50	
1500 - 15000	63	2	50	198 335 893
2000 - 20000	75	2 ½	65	198 335 894
3000 - 30000	75	2 ½	65	198 335 894
8000 - 60000	75	2 ½	65	198 335 894



Float PVDF (2)

Scale range [l/h]	d [mm]	Inch	DN [mm]	Without magnet Code	With magnet (bistabil) Code
50 - 500	32	1	25	198 335 455	198 335 470
100 - 1000	32	1	25	198 335 455	198 335 470
150 - 1500	40	1 ¼	32	198 335 455	198 335 470
250 - 2500	40	1 ¼	32	198 335 455	198 335 470
200 - 2000	50	1 ½	40	198 335 456	198 335 471
300 - 3000	50	1 ½	40	198 335 457	198 335 471
600 - 6000	50	1 ½	40	198 335 457	198 335 471
600 - 6000	63	2	50	198 335 457	198 335 471
1000 - 10000	63	2	50	198 335 457	198 335 471
1500 - 15000	63	2	50	198 335 458	198 335 472
2000 - 20000	75	2 ½	65	198 335 459	198 335 473
3000 - 30000	75	2 ½	65	198 335 459	198 335 473
8000 - 60000	75	2 ½	65	198 335 460	198 335 474



Guiding rod (10)

Model:

- Only for DN50 (1'500 - 15'000 l/h) and DN65 (all metering ranges)

Scale range [l/h]	d [mm]	Inch	DN [mm]	Peek Code	Stainless steel (V4A) Code	PVDF Code	
1500 - 15000	63	2	50	198 335 985	198 335 098	198 335 984	
2000 - 20000	75	2 ½	65	198 335 985	198 335 098	198 335 984	
3000 - 30000	75	2 ½	65	198 335 985	198 335 098	198 335 984	
8000 - 80000	75	2 ½	65	198 335 985	198 335 098	198 335 984	



Insert guiding rod PVDF (for 10)

Model:

- Only for DN50 (1'500 - 15'000 l/h) and DN65 (all metering ranges)

Scale range [l/h]	d [mm]	Inch	DN [mm]	for PEEK Code	for PVDF/SS Code	
1500 - 15000	63	2	50	198 335 986	198 335 953	
2000 - 20000	75	2 ½	65	198 335 987	198 335 954	
3000 - 30000	75	2 ½	65	198 335 987	198 335 954	
8000 - 60000	75	2 ½	65	198 335 987	198 335 954	



Flow value indicator PS (8)

Model:

- For all dimensions type 335/350

d [mm]	Inch	DN [mm]	Flow value indica- tor Code	
32	1	25	198 335 990	
40	1 ¼	32	198 335 990	
50	1 ½	40	198 335 990	
63	2	50	198 335 990	
75	2 ½	65	198 335 990	



O-rings (7)

d [mm]	Inch	DN [mm]	EPDM Code	FPM Code	
32	1	25	748 410 008	749 410 008	
40	1 ¼	32	748 410 009	749 410 009	
50	1 ½	40	748 410 010	749 410 010	
63	2	50	748 410 011	749 410 011	
75	2 ½	65	748 410 014	749 410 014	



Union nut (5)

Union nut not useable for the special version with taper tube in PVDF

d [mm]	Inch	DN [mm]	PVC-U Code	PVC-C Code	ABS Code	PP-H Code	PVDF Code	
32	1	25	721 890 008	723 690 008	729 890 408	727 890 408	735 690 408	
40	1 ¼	32	721 890 009	723 690 009	729 890 409	727 890 409	735 690 409	
50	1 ½	40	721 890 010	723 690 010	729 890 410	727 890 410	735 690 410	
63	2	50	721 890 011	723 690 011	729 890 411	727 890 411	735 690 411	
75	2 ½	65	198 806 429	-	-	198 806 421	198 806 422	



Union end / Socket (6)

For DN65 PVDF only spigot

d [mm]	Inch	DN [mm]	PVC-U Code	PVC-C Code	ABS Code	PP-H Code	PVDF Code
32	1	25	721 500 108	723 800 108	729 800 108	727 500 108	735 600 108
40	1 ¼	32	721 500 109	723 800 109	729 800 109	727 500 109	735 600 109
50	1 ½	40	721 500 110	723 800 110	729 800 110	727 500 110	735 600 110
63	2	50	721 500 111	723 800 111	729 800 111	727 500 111	735 600 111
75	2 ½	65	721 600 112	700 253 867	700 246 112	700 253 866	-

d [mm]	Inch	DN [mm]	PE80 Code
32	1	25	734 600 108
40	1 ¼	32	734 600 109
50	1 ½	40	734 600 110
63	2	50	734 600 111
75	2 ½	65	700 246 419



Union end / Spigot (6)

d [mm]	Inch	DN [mm]	PP-H Code	PVDF Code	PE100 Code
32	1	25	727 508 508	735 608 608	753 608 608
40	1 ¼	32	727 508 509	735 608 609	753 608 609
50	1 ½	40	727 508 510	735 608 610	753 608 610
63	2	50	727 508 511	735 608 611	753 608 611
75	2 ½	65	700 256 401	175 483 013	700 246 420



Exchange kit

Model:

- Exchange kit consisting of: guiding rod (PVDF/V4A), insert guiding rod and insert bottom
- Only for DN50 (1'500 - 15'000 l/h) and DN65 (all metering ranges)

Scale range [l/h]	d [mm]	Inch	DN [mm]	Code PVDF Code
1500 - 15000	63	2	50	198 335 895
2000 - 20000	75	2 ½	65	198 335 896
3000 - 30000	75	2 ½	65	198 335 896
8000 - 80000	75	2 ½	65	198 335 896

Variable area flow meter type 350

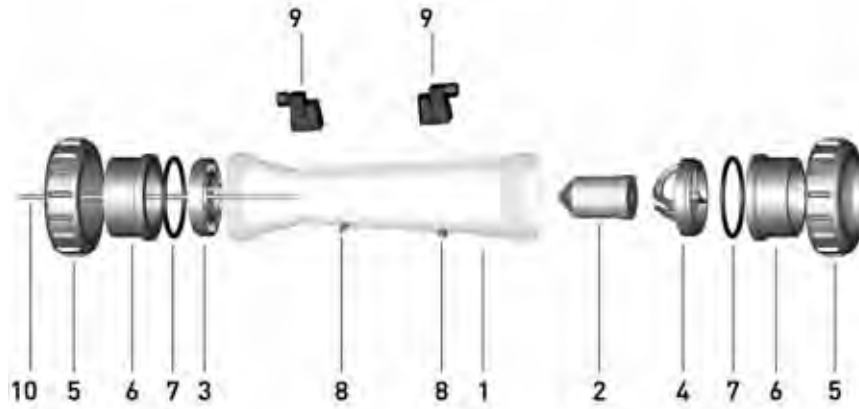

Taper tube with water scale (1)



Scale range [l/h]	d [mm]	Inch	DN [mm]	PVC-U transpar- ent Code	Polyamid Code	Polysulfon Code
50 - 500	32	1	25	198 350 055	198 350 070	198 350 085
100 - 1000	32	1	25	198 350 056	198 350 071	198 350 086
150 - 1500	40	1 ¼	32	198 350 057	198 350 072	198 350 087
250 - 2500	40	1 ¼	32	198 350 058	198 350 073	198 350 088
200 - 2000	50	1 ½	40	198 350 059	198 350 074	198 350 089
300 - 3000	50	1 ½	40	198 350 060	198 350 075	198 350 090
600 - 6000	50	1 ½	40	198 350 061	198 350 076	198 350 091
600 - 6000	63	2	50	198 350 062	198 350 077	198 350 092
1000 - 10000	63	2	50	198 350 063	198 350 078	198 350 093
1500 - 15000	63	2	50	198 350 064	198 350 079	198 350 094
2000 - 20000	75	2 ½	65	198 350 065	198 350 080	198 350 095
3000 - 30000	75	2 ½	65	198 350 066	198 350 081	198 350 096
8000 - 60000	75	2 ½	65	198 350 067	198 350 082	198 350 097

Taper tube without scale (1)



Scale range [l/h]	d [mm]	Inch	DN [mm]	PVC-U transpar- ent Code	Polyamid Code	Polysulfon Code
50 - 500	32	1	25	198 350 255	198 350 270	198 350 285
100 - 1000	32	1	25	198 350 256	198 350 271	198 350 286
150 - 1500	40	1 ¼	32	198 350 257	198 350 272	198 350 287
250 - 2500	40	1 ¼	32	198 350 258	198 350 273	198 350 288
200 - 2000	50	1 ½	40	198 350 259	198 350 274	198 350 289
300 - 3000	50	1 ½	40	198 350 260	198 350 275	198 350 290
600 - 6000	50	1 ½	40	198 350 261	198 350 276	198 350 291
600 - 6000	63	2	50	198 350 262	198 350 277	198 350 292
1000 - 10000	63	2	50	198 350 263	198 350 278	198 350 293
1500 - 15000	63	2	50	198 350 264	198 350 279	198 350 294
2000 - 20000	75	2 ½	65	198 350 265	198 350 280	198 350 295
3000 - 30000	75	2 ½	65	198 350 266	198 350 281	198 350 296
8000 - 60000	75	2 ½	65	198 350 267	198 350 282	198 350 297



Insert PVDF (3,4)

Scale range [l/h]	d [mm]	Inch	DN [mm]	top (4) Code	bottom (3) Code	bottom (3) for PEEK guiding rod Code
50 - 500	32	1	25	198 335 970	198 335 977	
100 - 1000	32	1	25	198 335 970	198 335 977	
150 - 1500	40	1 ¼	32	198 335 971	198 335 978	
250 - 2500	40	1 ¼	32	198 335 971	198 335 978	
200 - 2000	50	1 ½	40	198 335 972	198 335 979	
300 - 3000	50	1 ½	40	198 335 972	198 335 979	
600 - 6000	50	1 ½	40	198 335 972	198 335 979	
600 - 6000	63	2	50	198 335 973	198 335 980	
1000 - 10000	63	2	50	198 335 973	198 335 980	
1500 - 15000	63	2	50	198 335 974		198 335 982
2000 - 20000	75	2 ½	65	198 335 975		198 335 981
3000 - 30000	75	2 ½	65	198 335 975		198 335 981
8000 - 60000	75	2 ½	65	198 335 975		198 335 981

Scale range [l/h]	d [mm]	Inch	DN [mm]	bottom (3) for PVDF/SS guiding rod Code
50 - 500	32	1	25	
100 - 1000	32	1	25	
150 - 1500	40	1 ¼	32	
250 - 2500	40	1 ¼	32	
200 - 2000	50	1 ½	40	
300 - 3000	50	1 ½	40	
600 - 6000	50	1 ½	40	
600 - 6000	63	2	50	
1000 - 10000	63	2	50	
1500 - 15000	63	2	50	198 335 893
2000 - 20000	75	2 ½	65	198 335 894
3000 - 30000	75	2 ½	65	198 335 894
8000 - 60000	75	2 ½	65	198 335 894



Float PVDF (2)

Scale range [l/h]	d [mm]	Inch	DN [mm]	Without magnet Code	With magnet Code
50 - 500	32	1	25	198 335 455	198 335 470
100 - 1000	32	1	25	198 335 455	198 335 470
150 - 1500	40	1 ¼	32	198 335 455	198 335 470
250 - 2500	40	1 ¼	32	198 335 455	198 335 470
200 - 2000	50	1 ½	40	198 335 456	198 335 471
300 - 3000	50	1 ½	40	198 335 457	198 335 471
600 - 6000	50	1 ½	40	198 335 457	198 335 471
600 - 6000	63	2	50	198 335 457	198 335 471
1000 - 10000	63	2	50	198 335 457	198 335 471
1500 - 15000	63	2	50	198 335 458	198 335 472
2000 - 20000	75	2 ½	65	198 335 459	198 335 473
3000 - 30000	75	2 ½	65	198 335 459	198 335 473
8000 - 60000	75	2 ½	65	198 335 460	198 335 474



Guiding rod (10)

Model:

- Only for DN50 (1'500 - 15'000 l/h) and DN65 (all metering ranges)

Scale range [l/h]	d [mm]	Inch	DN [mm]	Peek Code	Stainless steel Code	PVDF Code
1500 - 15000	63	2	50	198 350 980	198 350 098	198 350 981
2000 - 20000	75	2 ½	65	198 350 980	198 350 098	198 350 981
3000 - 30000	75	2 ½	65	198 350 980	198 350 098	198 350 981
8000 - 60000	75	2 ½	65	198 350 980	198 350 098	198 350 981



Insert guiding rod PVDF (for 10)

Model:

- Only for DN50 (1'500 - 15'000 l/h) and DN65 (all metering ranges)

Scale range [l/h]	d [mm]	Inch	DN [mm]	for PEEK & stain- less steel Code	for PVDF/SS Code
1500 - 15000	63	2	50	198 335 986	198 335 953
2000 - 20000	75	2 ½	65	198 335 987	198 335 954
3000 - 30000	75	2 ½	65	198 335 987	198 335 954
8000 - 60000	75	2 ½	65	198 335 987	198 335 954



Flow value indicator PS (8)

Model:

- For all dimensions type 335/350

d [mm]	Inch	DN [mm]	Flow value indica- tor Code
32	1	25	198 335 990
40	1 ¼	32	198 335 990
50	1 ½	40	198 335 990
63	2	50	198 335 990
75	2 ½	65	198 335 990



O-rings (7)

d [mm]	Inch	DN [mm]	EPDM Code	FPM Code
32	1	25	748 410 008	749 410 008
40	1 ¼	32	748 410 009	749 410 009
50	1 ½	40	748 410 010	749 410 010
63	2	50	748 410 011	749 410 011
75	2 ½	65	748 410 014	749 410 014



Union nut (5)

Union nut not useable for the special version with taper tube in PVDF

d [mm]	Inch	DN [mm]	PVC-U Code	PVC-C Code	ABS Code	PP-H Code	PVDF Code
32	1	25	721 890 008	723 690 008	729 890 408	727 890 408	735 690 408
40	1 ¼	32	721 890 009	723 690 009	729 890 409	727 890 409	735 690 409
50	1 ½	40	721 890 010	723 690 010	729 890 410	727 890 410	735 690 410
63	2	50	721 890 011	723 690 011	729 890 411	727 890 411	735 690 411
75	2 ½	65	198 806 429	-	-	198 806 421	198 806 422



Union end / Socket (6)

For DN65 PVDF only spigot

d [mm]	Inch	DN [mm]	PVC-U Code	PVC-C Code	ABS Code	PP-H Code	PVDF Code
32	1	25	721 500 108	723 800 108	729 800 108	727 500 108	735 600 108
40	1 ¼	32	721 500 109	723 800 109	729 800 109	727 500 109	735 600 109
50	1 ½	40	721 500 110	723 800 110	729 800 110	727 500 110	735 600 110
63	2	50	721 500 111	723 800 111	729 800 111	727 500 111	735 600 111
75	2 ½	65	721 600 112	700 253 867	700 246 112	700 253 866	-

d [mm]	Inch	DN [mm]	PE80 Code
32	1	25	734 600 108
40	1 ¼	32	734 600 109
50	1 ½	40	734 600 110
63	2	50	734 600 111
75	2 ½	65	700 246 419



Union end / Spigot (6)

d [mm]	Inch	DN [mm]	PP-H Code	PVDF Code	PE100 Code
32	1	25	727 508 508	735 608 608	753 608 608
40	1 ¼	32	727 508 509	735 608 609	753 608 609
50	1 ½	40	727 508 510	735 608 610	753 608 610
63	2	50	727 508 511	735 608 611	753 608 611
75	2 ½	65	700 256 401	175 483 013	700 246 420



Exchange kit

Model:

- Exchange kit consisting of: guiding rod (PVDF/V4A), insert guiding rod and insert bottom
- Only for DN50 (1'500 - 15'000 l/h) and DN65 (all metering ranges)

Scale range [l/h]	d [mm]	Inch	DN [mm]	Code
1500 - 15000	63	2	50	198 350 895
2000 - 20000	75	2 ½	65	198 350 896
3000 - 30000	75	2 ½	65	198 350 896
8000 - 80000	75	2 ½	65	198 350 896

Spare part for variable area flow meter SK50-SK73/SK500-SK730

Short version taper tube Polysulfone

Type	d [mm]	DN [mm]	Code
SK 50 / 500	16	10	198 801 341
SK 51 / 510	16	10	198 801 342
SK 52 / 520	16	10	198 801 343
SK 60 / 600	20	15	198 801 449
SK 61 / 610	20	15	198 801 450
SK 62 / 620	20	15	198 801 451
SK 70 / 700	32	25	198 801 445
SK 71 / 710	32	25	198 801 338
SK 72 / 720	32	25	198 801 339
SK 73 / 730	32	25	198 801 340

Short version taper tube PVC-U transparent

Type	d [mm]	DN [mm]	Code
SK 50 / 500	16	10	198 803 790
SK 51 / 510	16	10	198 803 791
SK 52 / 520	16	10	198 803 792
SK 60 / 600	20	15	198 803 793
SK 61 / 610	20	15	198 803 794
SK 62 / 620	20	15	198 803 795
SK 70 / 700	32	25	198 803 796
SK 71 / 710	32	25	198 803 797
SK 72 / 720	32	25	198 803 798
SK 73 / 730	32	25	198 803 799

Short version float PVDF Without magnet

Type	d [mm]	DN [mm]	Code
SK 50 / 51 / 52	16	10	198 806 219
SK 60 / 61 / 62	20	15	198 806 220
SK 70 / 71 / 72 / 73	32	25	198 806 221

Short version float PVDF With magnet bistable

Type	d [mm]	DN [mm]	Code
SK 500 / 510 / 520	16	10	198 806 222
SK 600 / 610 / 620	20	15	198 806 223
SK 700 / 710 / 720 / 730	32	25	198 806 224

Short version float PTFE Without magnet

Type	d [mm]	DN [mm]	Code
SK 73	32	25	198 807 166

Short version top insert PVDF

Type	d [mm]	DN [mm]	Code
SK 50 / 500; 51 / 510; 52 / 520	16	10	198 807 188
SK 60 / 600; 61 / 610; 62 / 620	20	15	198 807 187
SK 70 / 700; 71 / 710; 72 / 720; 73 / 730	32	25	198 807 182

Pneumatic rotary actuators PA

Pneumatic actuator type PA11/PA21

Fail safe to close (FC)



Type	DN-DN [mm]	Inch [inch]	Code	
PA 11 FC	10 - 25	3/8 - 1	198 150 127	
PA 21 FC	32 - 50	1 1/4 - 2	198 150 130	

Fail safe to open (FO)



Type	DN-DN [mm]	Inch [inch]	Code	
PA 11 FO	10 - 25	3/8 - 1	198 150 128	
PA 21 FO	32 - 50	1 1/4 - 2	198 150 131	

Double action (DA)



Type	DN-DN [mm]	Inch [inch]	Code	
PA 11 DA	10 - 25	3/8 - 1	198 150 129	
PA 21 DA	32 - 50	1 1/4 - 2	198 150 132	

Fail safe to close (FC) with stroke limiter



Type	DN-DN [mm]	Inch [inch]	Code	
PA 11 FC	10 - 25	3/8 - 1	198 150 144	
PA 21 FC	32 - 50	1 1/4 - 2	198 150 147	

Fail safe to open (FO) with stroke limiter



Type	DN-DN [mm]	Inch [inch]	Code	
PA 11 FO	10 - 25	3/8 - 1	198 150 145	
PA 21 FO	32 - 50	1 1/4 - 2	198 150 148	

Double action (DA) with stroke limiter



Type	DN-DN [mm]	Inch [inch]	Code	
PA 11 DA	10 - 25	3/8 - 1	198 150 146	
PA 21 DA	32 - 50	1 1/4 - 2	198 150 149	

Pneumatic actuator type PA30 PA90

Fail safe to close/fail safe to open (FC/FO)



* Only valid for butterfly valve type 240, 241, 242 and ball valve type 230 - 235

Type	hard anodized Code	nickel plated Code	hard anodized with stroke limiter Code	epoxy coated Code
PA 30 FC/FO	198 800 757	198 800 034	-	198 811 194
* PA 30 FO	198 811 025	-	-	-
PA 35 FC/FO	198 800 037	198 800 052	-	198 800 029
* PA 35 FO	198 811 026	-	-	-
PA 40 FC/FO	198 800 728	198 800 004	198 800 017	198 800 025
* PA 40 FO	198 811 027	-	-	-
PA 45 FC/FO	198 800 039	198 800 054	-	-
* PA45 FO	198 811 028	-	-	-
PA 50 FC/FO	198 800 729	198 800 005	198 800 018	198 800 026
* PA50 FO	198 811 029	-	-	-
PA 55 FC/FO	198 800 041	198 800 056	-	198 811 190
* PA 55 FO	198 811 030	-	-	-
PA 60 FC/FO	198 800 730	198 800 006	198 800 019	-
PA 65 FC/FO	198 800 043	198 800 058	-	-
PA 70 FC/FO	198 800 731	198 800 007	198 800 020	198 800 028
PA 70 FO	198 811 198	-	-	-
PA 75 FC/FO	198 800 045	198 800 060	-	-
PA 80 FC/FO	198 800 047	198 800 062	-	-

Type		D1 [mm]	D2 [mm]	D3[M] [mm]	D4 [inch]	D5 [mm]	L [mm]	L2 [mm]	L3 [mm]	L4 [mm]	L5 [mm]	H [mm]	H1 [mm]
PA 30 FC/FO	F04	42	30	M5x9		10	276	11	35	70	32	102	70
* PA 30 FO	F04	42	30	M5x9	1/8	10	276	11	35	70	32	102	70
PA 35 FC/FO	F05	50	35	M6x11		12	326	14	35	70	32	111	78
* PA 35 FO	F05	50	35	M6x11	1/8	12	326	14	35	70	32	111	78
PA 40 FC/FO	F05	50	35	M6x11		12	370	14	35	70	32	129	86
* PA 40 FO	F05	50	35	M6x11	1/8	12	370	14	35	70	32	129	86
PA 45 FC/FO	F07	70	55	M8x15	1/8	15	411	17	35	70	32	139	96
* PA45 FO	F07	70	55	M8x15	1/8	15	411	17	35	70	32	139	96
PA 50 FC/FO	F07	70	55	M8x15		15	423	17	35	70	32	149	106
* PA50 FO	F07	70	55	M8x15	1/8	15	423	17	35	70	32	149	106
PA 55 FC/FO	F10	102	70	M10x17		19	452	22	35	70	32	161	118
* PA 55 FO	F10	102	70	M10x17	1/8	19	452	22	35	70	32	161	118
PA 60 FC/FO	F10	102	70	M10x17	1/8	19	503	22	35	70	32	173	130
PA 65 FC/FO	F12	125	85	M12x21	1/4		648	27			32	191	148
PA 70 FC/FO	F12	125	85	M12x21			663	27			32	196	153
PA 70 FO	F12	125	85	M12x21	1/4		663	27			32	196	153
PA 75 FC/FO	F14	140	100	M16x25	1/4		824	36			32	229	186
PA 80 FC/FO	F14	140	100	M16x25	1/4		918	36			32	241	198

Type	H2 [mm]	H3 [mm]	H4 [mm]	H5 [mm]	H6 [mm]	H7 [mm]	H8 [mm]
PA 30 FC/FO	21	18	65	13	20	36	
* PA 30 FO	21	18	65	13	20	36	
PA 35 FC/FO	21	18	72	13	20	36	
* PA 35 FO	21	18	72	13	20	36	
PA 40 FC/FO	25	21	80	13	30	36	
* PA 40 FO	25	21	80	13	30	36	
PA 45 FC/FO	25	21	90	16	30	36	
* PA45 FO	25	21	90	16	30	36	
PA 50 FC/FO	25	26	100	17	30	36	
* PA50 FO	25	26	100	17	30	36	
PA 55 FC/FO	25	25	112	19	30	36	
* PA 55 FO	25	25	112	19	30	36	
PA 60 FC/FO	25	32	124	19	30	36	
PA 65 FC/FO	24	34	137				22
PA 70 FC/FO	24	38	145				24

table continued next page

Type	H2 [mm]	H3 [mm]	H4 [mm]	H5 [mm]	H6 [mm]	H7 [mm]	H8 [mm]
PA 70 FO	24	38	145				24
PA 75 FC/FO	24	43	166				27
PA 80 FC/FO	24	44	180				32

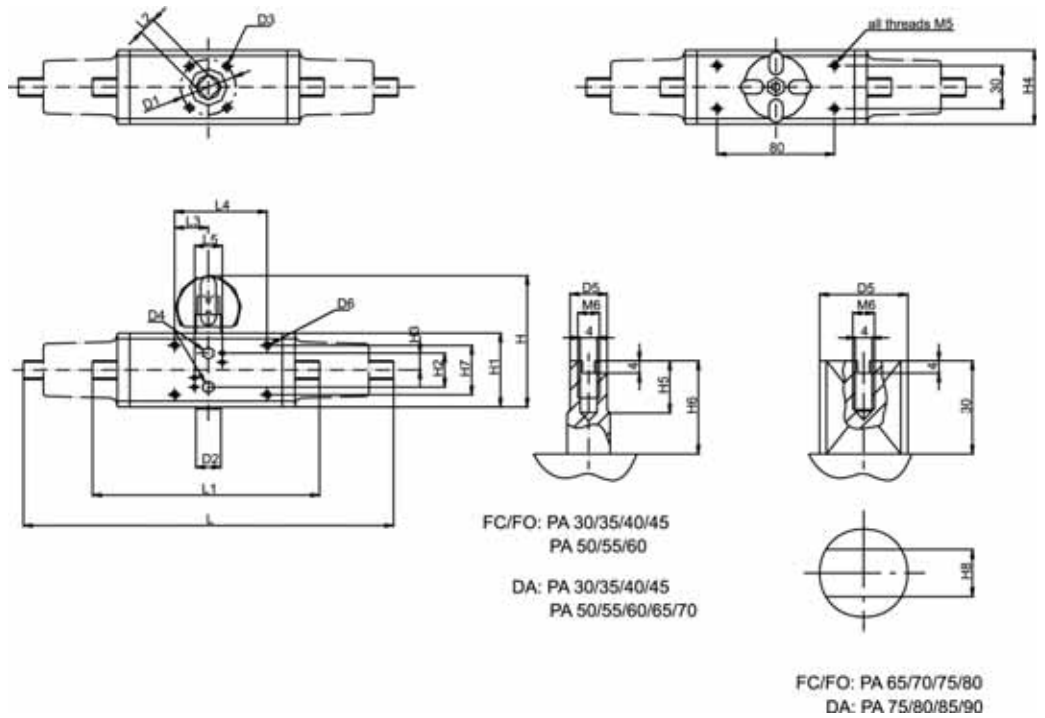

Double acting (DA)

Type	hard anodized Code
PA 30 DA	198 800 737
PA 35 DA	198 800 758
PA 40 DA	198 800 759
PA 45 DA	198 800 040
PA 50 DA	198 800 733
PA 55 DA	198 800 042
PA 60 DA	198 800 734
PA 65 DA	198 800 044
PA 70 DA	198 800 735
PA 75 DA	198 800 046
PA 80 DA	198 800 048
PA 85 DA	198 800 050
PA 90 DA	198 800 051

Type		D1 [mm]	D2 [mm]	D3[M] [mm]	D4 [inch]	D5 [mm]	L1 [mm]	L2 [mm]	L3 [mm]	L4 [mm]	L5 [mm]	H [mm]	H1 [mm]
PA 30 DA	F03	36	25	M5x9	1/8	9	177	9	35	70		92	60
PA 35 DA	F03	42	30	M5x9	1/8	10	190	11	35	70		98	66
PA 40 DA	F05	42	30	M5x9	1/8	10	198	11	35	70		102	70
PA 45 DA	F05	50	35	M6x11	1/8	12	235	14	35	70		111	78
PA 50 DA	F05	50	35	M6x11	1/8	12	250	14	35	70		129	86
PA 55 DA	F07	70	55	M8x15	1/8	15	279	17	35	70		139	96
PA 60 DA	F07	70	55	M8x15	1/8	15	341	17	35	70		149	106
PA 65 DA	F10	102	70	M10x17	1/8	19	350	22	35	70		161	118
PA 70 DA	F10	102	70	M10x17	1/8	19	381	22	35	70		173	130
PA 75 DA	F12	125	85	M12x21	1/4		416	27			32	191	148
PA 80 DA	F12	125	85	M12x21	1/4		466	27			32	197	153
PA 85 DA	F14	140	100	M16x25	1/4		555	36			32	229	186
PA 90 DA	F14	140	100	M16x25	1/4		581	36			32	241	198

table continued next page

Type	H2 [mm]	H3 [mm]	H4 [mm]	H5 [mm]	H6 [mm]	H7 [mm]	H8 [mm]
PA 30 DA	25	12	55	10	20	36	
PA 35 DA	25	13	60	13	20	36	
PA 40 DA	21	18	65	13	20	36	
PA 45 DA	21	18	72	13	20	36	
PA 50 DA	25	21	80	13	30	36	
PA 55 DA	25	21	90	16	30	36	
PA 60 DA	25	26	100	17	30	36	
PA 65 DA	25	25	112	19	30	36	
PA 70 DA	25	32	124	19	30	36	
PA 75 DA	24	34	137				22
PA 80 DA	24	38	145				24
PA 85 DA	24	43	166				27
PA 90 DA	24	44	180				32

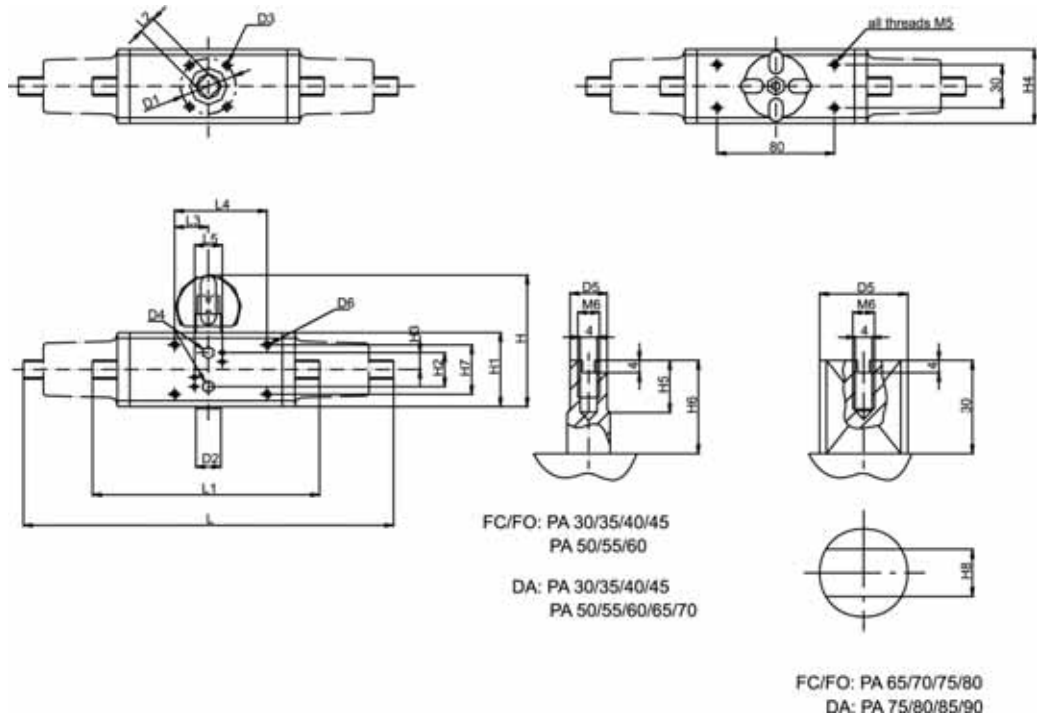

Accessories for pneumatic rotary actuators

For pneumatic actuators type PA30-PA55 and PA11/21

Namur connecting plate

- PA30 - PA55 FC/FO, PA30 - PA65 DA



DN [mm]	Series PA11/21 Code	Series PA30-55 Code	
15	199 190 378	199 190 275	
20	199 190 378	199 190 275	
25	199 190 378	199 190 275	
32	199 190 378	199 190 275	
40	199 190 378	199 190 275	
50	199 190 378	199 190 275	

For actuator units pneumatic type PA11 - PA90

Namur mounting flange



No	Code	
3	199 190 281	

Limit switch box with 2 auxiliary switches

- Including namur mounting flange

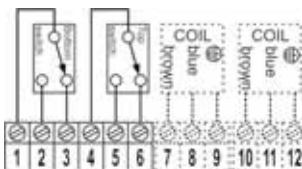
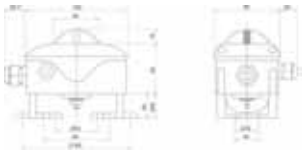

Voltage	Code	
250 V ~/10 A	199 190 282	

Limit switch box with 2 inductive auxiliary switches NPN With luminous diode

- Including namur mounting flange

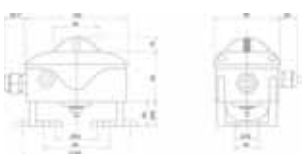

Voltage	Code	
10...30 V / 0.1 A	199 190 283	



Limit switch box with 2 inductive auxiliary switches PNP With luminous diode

- Including namur mounting flange

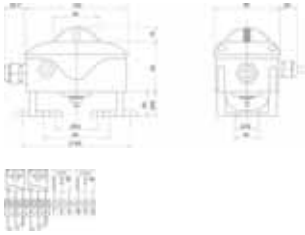

Voltage	Code	
10...30 V/ 0.1 A	199 190 284	



Limit switch box with 2 inductive auxiliary switches Namur Exei (intrinsically safe)

- Including namur mounting flange

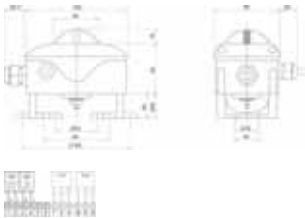

Voltage	Code	
5-15 V	199 190 285	



Limit switch box with 2 auxiliary switches Eexd

- Including namur mounting flange

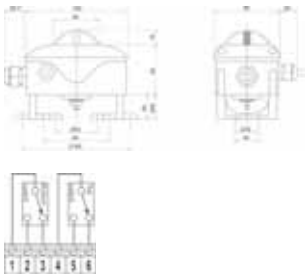

Voltage	Code	
250 V ~/5 A	199 190 286	



Limit switch box with 2 auxiliary switches With gold contact

- Including namur mounting flange

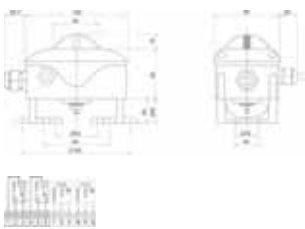

Voltage	Code	
30 V =/ 1-100 mA	199 190 287	

Electric actuators

Electric actuator type EA11



Note:

F05 (WS11/14) per EN ISO 5211 with adapter 198.000.587

Voltage	Code	
100-230 V~ 24 V=/ ~	198 150 180 198 150 181	

Electric actuator type EA21



Note:

F05 (WS11/14) per EN ISO 5211 with adapter 198.000.587

Voltage	Code	
100-230 V~ 24 V=/ ~	198 150 182 198 150 183	

Electric actuator type EA31



Note:

F07 (WS 17) per EN ISO 5211

Voltage	Code	
100-230 V~ 24 V=/ ~	198 150 184 198 150 185	

Electric actuator type EA42



Note:

F07 (WS 22) per EN ISO 5211

Voltage	Code	
100-230 V~ 24 V=/ ~	198 150 186 198 150 187	

Accessories for electric actuators

For electric actuators

Type EA11/EA21/EA31/EA42

Heating element



Voltage	Code	
24 V=	199 190 086	

Fail safe return incl. battery kit



Voltage	Code	
24 V=	199 190 085	

Heating element + fail safe return incl. battery kit



Voltage	Code	
24 V=	199 190 087	

Battery kit (spare)



Voltage	Code	
24 V=	198 151 317	

Limit switch kit with mechanical limit switches AgNi



Voltage	Code	
250 V ~6 A	199 190 092	

For electric actuators
Type EA21/EA31/EA42

Testing adapter kit



Code	
198 151 426	



Monitoring print

Code	
199 190 099	



Cycle time extension

Model:

- Monitoring print required

Code	
199 190 080	



Cycle time monitoring

Model:

- Monitoring print required

Code	
199 190 082	



Cycle counter

Model:

- Monitoring print required

Code	
199 190 083	



Motor current monitoring

Model:

- Monitoring print required

Code	
199 190 081	



Position signalization

Model:

- Enables a 4... 20mA feedback signal
- Must be used with either the PE25 positioner or the monitoring print

Code	
199 190 084	



Positioner PE25

Model:

- Positioner must use position signalization
- ** galvanic isolated set value inputs
- * not galvanic isolated set value inputs

Voltage	Code	
* 24 V=	199 190 100	
** 24 V=	199 190 101	



Limit switch kit with gold contacts Au

Voltage	Code	
30 V=, 100mA	199 190 093	



Limit switch kit with inductive switches PNP

Voltage	Code	
5-30 V= 0,1 A	199 190 095	



Assembly kit for 4 limit switches

Model:

- Limit switches need to be ordered separately

Code	
199 190 097	



Limit switch kit with inductive switches NPN

Voltage	Code	
5-30 V= 0,1 A	199 190 096	



Limit switch kit with mechanical limit switches Middle position

Voltage	Code	
4-30 V= 1-100 mA	199 190 094	

Pneumatic stroke actuators

Accessories and spare parts for DIASTAR

Indicator cap for DIASTAR

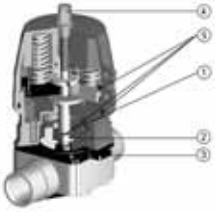

Pos	d [mm]	DN [mm]	Serie 028 FC Code	Serie 025 FC Code	Serie 025 FO Code	Serie 025 DA Code
4	20	15	198 806 639	198 806 639	198 806 639	198 806 639
4	25	20	198 806 639	198 806 639	198 806 639	198 806 639
4	32	25	198 806 639	198 806 640	198 806 639	198 806 639
4	40	32	198 806 640	198 806 640	198 806 640	198 806 640
4	50	40	198 806 640	198 806 640	198 806 640	198 806 640
4	63	50	198 806 640	198 806 640	198 806 640	198 806 640
4	75	65		198 806 376	198 806 376	198 806 376
4	90	80		198 806 376	198 806 376	198 806 376
4	110	100		198 806 376	198 806 376	198 806 376
4	160	150		198 806 376	198 806 376	198 806 376

Compression set complete Consisting of compressor and diaphragm holder

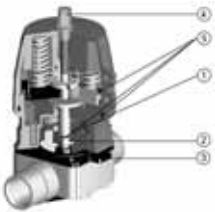

d [mm]	Inch	DN [mm]	EPDM Code	PTFE/EPDM Code
20	1/2	15	198 000 320	198 000 326
25	3/4	20	198 000 321	198 000 327
32	1	25	198 000 322	198 000 328
40	1 1/4	32	198 000 323	198 000 329
50	1 1/2	40	198 000 324	198 000 330
63	2	50	198 000 325	198 000 331
75	2 1/2	65	198 000 268	198 000 269
90	3	80	198 000 270	198 000 271
110	4	100	198 000 272	198 000 273
160	6	150	198 000 274	198 000 275

Diaphragms for DIASTAR

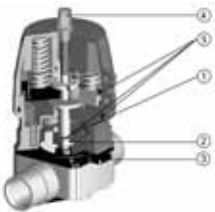

d [mm]	DN [mm]	EPDM Code	FPM Code	NBR Code	CSM Code	PTFE/EPDM Code
20	15	161 481 022	161 481 092	161 311 710	161 311 728	161 311 698
25	20	161 481 023	161 481 093	161 311 711	161 311 729	161 311 699
32	25	161 481 024	161 481 094	161 311 712	161 311 730	161 311 700
40	32	161 481 025	161 481 095	161 311 713	161 311 731	161 311 701
50	40	161 481 026	161 481 096	161 311 714	161 311 732	161 311 702
63	50	161 481 027	161 481 097	161 311 715	161 311 733	161 311 703
75	65	161 481 028	161 481 098	161 480 231	161 480 237	161 480 240
90	80	161 481 029	161 481 099	161 480 232	161 480 238	161 480 241
110	100	161 481 030	161 481 100	161 480 233	161 480 239	161 480 242
160	150	161 482 754	161 481 102	161 482 751	161 482 757	161 482 760

d [mm]	DN [mm]	PTFE/FPM Code	PTFE/EPDM HP Code
20	15	161 481 926	161 484 452
25	20	161 481 927	161 484 453
32	25	161 481 928	161 484 454
40	32	161 481 929	161 484 455
50	40	161 481 930	161 484 456
63	50	161 481 931	161 484 457
75	65	161 481 932	161 484 458
90	80		161 484 459
110	100		161 484 460
160	150		161 482 760

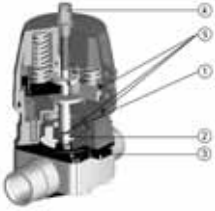

Seal set complete

Pos	DN [mm]	Serie 028 FC Serie 025 FO/DA Code	Serie 025 FC Code
5	15	198 000 332	198 000 333
5	20	198 000 333	198 000 333
5	25	198 000 333	198 000 334
5	32	198 000 334	198 000 335
5	40	198 000 335	198 000 336
5	50	198 000 335	198 000 336

Pneumatic actuator DIASTAR

Series 028 FC



d [mm]	DN [mm]	Inch	Size	for EPDM Code	for PTFE/EPDM Code
20	15	1/2	1	198 150 091	198 150 097
25	20	3/4	2	198 150 126	198 150 126
32	25	1	2	198 150 093	198 150 098
40	32	1 1/4	3	198 150 094	198 150 124
50	40	1 1/2	4	198 150 095	198 150 099
63	50	2	4	198 150 125	198 150 125

Series 025 FC



d [mm]	DN [mm]	Inch	Size	for EPDM Code	for PTFE/EPDM Code
20	15	1/2	2	198 150 087	198 150 962
25	20	3/4	2	198 150 963	198 150 963
32	25	1	3	198 150 088	198 150 964
40	32	1 1/4	4	198 150 965	198 150 965
50	40	1 1/2	5	198 150 089	198 150 966
63	50	2	5	198 150 090	198 150 967
75	65	2 1/2		198 150 736	198 150 736
90	80	3		198 150 737	198 150 737
110	100	4		198 150 738	198 150 738
160	150	6		198 150 739	

Series 025 FO



d [mm]	DN [mm]	Inch	Size	for PTFE/EPDM and EPDM Code
20	15	1/2	1	198 150 105
25	20	3/4	2	198 150 969
32	25	1	2	198 150 106
40	32	1 1/4	3	198 150 107
50	40	1 1/2	4	198 150 108
63	50	2	4	198 150 109
75	65	2 1/2		198 150 746
90	80	3		198 150 747
110	100	4		198 150 748
160	150	6		198 150 749



Series 025 DA

d [mm]	DN [mm]	Inch	Size	for EPDM Code	for PTFE/EPDM Code
20	15	½	1	198 150 100	198 150 100
25	20	¾	2	198 150 975	198 150 975
32	25	1	2	198 150 101	198 150 101
40	32	1 ¼	3	198 150 102	198 150 102
50	40	1 ½	4	198 150 103	198 150 103
63	50	2	4	198 150 104	198 150 104
75	65	2 ½		198 150 756	198 150 756
90	80	3		198 150 757	198 150 757
110	100	4		198 150 758	198 150 758
160	150	6		198 150 759	198 150 759

Diaseptic DIASTAR

Type 025 full plastic actuator PPS GF40



DN [mm]	FC Code	FO Code	DA Code
15	198 151 126	198 151 136	198 151 142
20	198 151 127	198 151 137	198 151 143
25	198 151 128	198 151 138	
32	198 151 129	198 151 139	198 151 145
40	198 151 130	198 151 140	198 151 146
50	198 151 131	198 151 141	198 151 147

Type 025 with stainless steel intermediate part



DN [mm]	FC size 1 Code	FC size 2 Code	FO Code	DA Code
8	198 151 148		198 151 156	198 151 163
15	198 151 149	198 151 150	198 151 157	198 151 164
20	198 151 151		198 151 158	198 151 165
25	198 151 152		198 151 159	198 151 166
40	198 151 154		198 151 161	198 151 168
50	198 151 155		198 151 162	198 151 169

Diaseptic type 028 plastic acuator PPS GF40



DN [mm]	FC Code
15	198 151 120
20	198 151 121
25	198 151 122
32	198 151 123
40	198 151 124
50	198 151 125

For diaphragm valve type DIASTAR

Electric position indicator with 2 auxiliary switches Ag Ni



- Connection: Plug

DN-DN [mm]	Inch [inch]	Type	Voltage	Code	
15 - 50	½ - 2	ER 52-1	250 V~ 6 A	199 190 305	
65 - 150	2 ½ - 6	ER 53-1	250 V~ 6 A	199 190 293	

Electric position indicator with 2 auxiliary switches With gold contact



- Connection: Plug

DN-DN [mm]	Inch [inch]	Type	Voltage	Code	
15 - 50	½ - 2	ER 52-2	4-30 V= 1-100 mA	199 190 306	
65 - 150	2 ½ - 6	ER 53-2	4-30 V= 1-100 mA	199 190 297	

Electric position indicator with 2 inductive switches NPN



- Connection: Plug

DN-DN [mm]	Inch [inch]	Type	Voltage	Code	
15 - 50	½ - 2	ER 52-3	5-30 V= 100 mA	199 190 307	
65 - 150	2 ½ - 6	ER 53-3	10-30 V= 100 mA	199 190 294	

Electric position indicator with 2 inductive switches PNP



- Connection: Plug

DN-DN [mm]	Inch [inch]	Type	Voltage	Code	
15 - 50	½ - 2	ER 52-4	5-30 V= 100 mA	199 190 308	
65 - 150	2 ½ - 6	ER 53-4	10-30 V= 100 mA	199 190 295	

Electric position indicator with 2 inductive switches Namur Exxi (intrinsically safe)



- Connection: Plug

DN-DN [mm]	Inch [inch]	Type	Voltage	Code	
15 - 50	½ - 2	ER 52-5	8 V=	199 190 309	
65 - 150	2 ½ - 6	ER 53-5	8 V=	199 190 296	

Electric position indicator with 2 auxiliary switches Eexd



- Connection: Cable, 2 m

DN-DN [mm]	Inch [inch]	Type	Voltage	Code	
15 - 50	½ - 2	ER 52-6	250 V ~ 5 A	199 190 405	
65 - 150	2 ½ - 6	ER 53-6	250 V ~ 5 A	199 190 298	



Adapter complete

- For combination Electric Position Indicator / Lift limiter / Manual override

DN-DN [mm]	Type	Ten/028 FC Code	Sixteen/025 FC Code	Ten/025 FO/DA Code	
- 15	ER 52	199 190 387	199 190 387	199 190 387	
- 20	ER 52	199 190 387	199 190 387	199 190 387	
- 25	ER 52	199 190 387	199 190 388	199 190 387	
- 32	ER 52	199 190 388	199 190 389	199 190 388	
- 40	ER 52	199 190 389	199 190 389	199 190 389	
- 50	ER 52	199 190 389	199 190 389	199 190 389	
65 - 150	ER 53		199 190 310	199 190 310	



Electric position indicator with reed contact Type ER-55 for Diastar DN 15-150

For one position open or closed

Furder position indicator with limit contact (198 804 875)

Connection: plug

Voltage: 250V ~ 200 mA

DN [mm]	Type	Ten/028 FC Code	Ten/Sixteen/025 FC/FO/DA Code	
15	ER 55-1	199 190 462	199 190 462	
20	ER 55-1	199 190 462	199 190 462	
25	ER 55-1	199 190 462	199 190 462	
32	ER 55-1	199 190 462	199 190 462	
40	ER 55-1	199 190 462	199 190 462	
50	ER 55-1	199 190 462	199 190 462	
65	ER 55-2		199 190 464	
80	ER 55-2		199 190 464	
100	ER 55-2		199 190 464	
150	ER 55-2		199 190 464	



Limit contact to ER55

Code	
198 804 875	

Accessories for pneumatic stroke actuators

For diaphragm valve type DIASTAR

Min./max. stroke limiter/manual override



Inch	Series 028-FC	Series 025-FC	Series 025-FO/DA
1/2	199 190 381	199 190 382	199 190 381
3/4	199 190 382	199 190 382	199 190 382
1	199 190 382	199 190 383	199 190 382
1 1/4	199 190 383	199 190 384	199 190 383
1 1/2	199 190 384	199 190 385	199 190 384
2	199 190 384	199 190 385	199 190 384
2 1/2-3		199 190 318	199 190 318
*4-6		199 190 319	199 190 319

DN-DN [mm]	Ten/028 FC Code	Sixteen/025 FC Code	Ten/025 FO/DA Code
- 15	199 190 381	199 190 382	199 190 381
- 20	199 190 382	199 190 382	199 190 382
- 25	199 190 382	199 190 383	199 190 382
- 32	199 190 383	199 190 384	199 190 383
- 40	199 190 384	199 190 385	199 190 384
- 50	199 190 384	199 190 385	199 190 384
65 - 80		199 190 318	199 190 318
* 100 - 150		199 190 319	199 190 319

NAMUR connector plate for DIASTAR DN15-50



Pos	DN [mm]	Ten/028 FC Code	Sixteen/025 FC Code	Ten/025 FO/DA Code
2	15	199 190 378	199 190 378	199 190 378
2	20	199 190 378	199 190 378	199 190 378
2	25	199 190 378	199 190 378	199 190 378
2	32	199 190 378	199 190 379	199 190 378
2	40	199 190 379	199 190 379	199 190 379
2	50	199 190 379	199 190 379	199 190 379

Pilot valves

Solenoid pilot valve type PV94

Pilot valve 3/2-ways

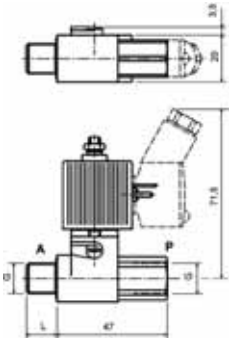

Model:

- For direct installation (including valve body and hollow screw)
- Port P compressed air connection G 1/8
- Port A actuator connection G 1/8
- With connector plug form C
- With adapter G1/8 to G1/4
- To pneumatic actuators FC/FO (single acting)
- Circuit function C: de-energized closed
- Valve material polyamid / brass

Voltage	DN [mm]	Compressed air connec- tion P	Actuator connec- tion	PN	kv-value ($\Delta p=1$ bar) [l/min]	NBR Code
24 V=	1.2	G 1/8	G 1/8	10	48	199 190 498
24 V, 50-60 Hz	1.2	G 1/8	G 1/8	10	48	199 190 499
110 V, 50-60 Hz	1.2	G 1/8	G 1/8	10	48	199 190 500
230 V, 50-60 Hz	1.2	G 1/8	G 1/8	10	48	199 190 501

Pilot valve 3/2-ways

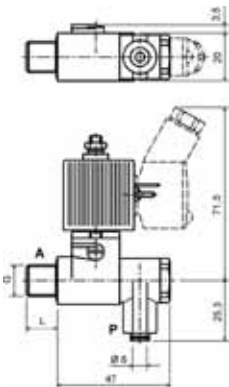

Model:

- For direct installation (including valve body and hollow screw)
- Port P compressed air connection tube push-in 6mm
- Port A actuator connection G 1/8
- With connector plug form C
- With adapter G1/8 to G1/4
- To pneumatic actuators FC/FO (single acting)
- Circuit function C: de-energized closed
- Valve material polyamid / brass

Voltage	DN [mm]	Compressed air connec- tion P	Actuator connec- tion	PN	kv-value ($\Delta p=1$ bar) [l/min]	NBR Code
24 V=	1.2	push-in	G 1/8	10	48	199 190 510
24 V, 50-60 Hz	1.2	push-in	G 1/8	10	48	199 190 511
110 V, 50-60 Hz	1.2	push-in	G 1/8	10	48	199 190 512
230 V, 50-60 Hz	1.2	push-in	G 1/8	10	48	199 190 513



Pilot valve 3/2-ways

Model:

- For direct installation (including valve body and hollow screw)
- Port P compressed air connection NPT 1/8
- Port A actuator connection G 1/8
- With connector plug form C
- With adapter G1/8 to G1/4
- To pneumatic actuators FC/FO (single acting)
- Circuit function C: de-energized closed
- Valve material polyamid / brass

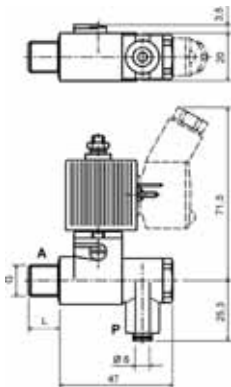

Voltage	DN [mm]	Compressed air connec- tion P	Actuator connec- tion	PN	kv-value ($\Delta p=1$ bar) [l/min]	NBR Code
24 V=	1.2	NPT 1/8	G 1/8	10	48	199 190 546
24 V AC	1.2	NPT 1/8	G 1/8	10	48	199 190 561
110 V, 50-60 Hz	1.2	NPT 1/8	G 1/8	10	48	199 190 547



Pilot valve 3/2-ways

Model:

- For direct installation (including valve body and hollow screw)
- Port P compressed air connection G 1/8
- Port A actuator connection G 1/8
- With connector plug form B
- With adapter G1/8 to G1/4
- To pneumatic actuators FC/FO (single acting)
- Circuit function C: de-energized closed
- Valve material polyamid / brass

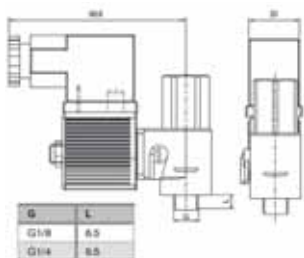

Voltage	DN [mm]	Compressed air connec- tion P	Actuator connec- tion	PN	kv-value ($\Delta p=1$ bar) [l/min]	NBR Code
24 V=	1.2	G 1/8	G 1/8	10	48	199 190 574
230 V, 50-60 Hz	1.2	G 1/8	G 1/8	10	48	199 190 572



Pilot valve 3/2-ways

Model:

- For direct installation (including valve body and hollow screw)
- Port P compressed air connection tube push-in 6mm
- Port A actuator connection G 1/8
- With connector plug form B
- With adapter G1/8 to G1/4
- To pneumatic actuators FC/FO (single acting)
- Circuit function C: de-energized closed
- Valve material polyamid / brass

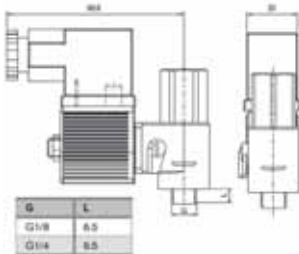

Voltage	DN [mm]	Compressed air connec- tion P	Actuator connec- tion	PN	kv-value ($\Delta p=1$ bar) [l/min]	NBR Code
24 V=	1.2	push-in	G 1/8	10	48	199 190 573
230 V, 50-60 Hz	1.2	push-in	G 1/8	10	48	199 190 571



Accessory

Model:

- Cable plug to DIN EN 175301-803 (DIN 43 650) form C

Voltage	Version	NBR Code
0-250 V	no circuitry	199 190 518
0-24 V	with LED	199 190 519
0-24 V	with LED and varistor	199 190 520
0-24 V	with rectifier LED and varistor	199 190 521
200-240 V	with LED	199 190 522
200-240 V	with LED and varistor	199 190 523



Accessory

Model:

- Cable plug, form B industrial standard

Voltage	Version	NBR Code
0-250 V	no circuitry	199 190 578
0-24 V	with LED	199 190 579
0-250 V	with LED	199 190 580
0-24 V	with rectifier LED	199 190 581

Solenoid pilot valve type PV95

Pilot valve 3/2-ways



Model:

- For direct installation (including valve body and hollow screw)
- Port P compressed air connection G 1/4
- Port A actuator connection G 1/8
- With connector plug form A
- With adapter G1/8 to G1/4
- To pneumatic actuators FC/FO (single acting)
- Circuit function C: de-energized closed
- Valve material: brass
- Power consumption: 24VA at AC inrush; 17VA/8W at AC hold; 8W at DC

Voltage	DN [mm]	Compressed air connec- tion P	Actuator connec- tion	PN	kv-value ($\Delta p=1$ bar) [l/min]	NBR Code
24 V=	2.0	G 1/4	G 1/8	10	120	199 190 532
24 V, 50-60 Hz	2.0	G 1/4	G 1/8	10	120	199 190 533
110 V, 50-60 Hz	2.0	G 1/4	G 1/8	10	120	199 190 534
230 V, 50-60 Hz	2.0	G 1/4	G 1/8	10	120	199 190 535

Pilot valve 3/2-ways



Model:

- For direct installation (including valve body and hollow screw)
- Port P compressed air connection NPT 1/8
- Port A actuator connection G 1/4
- With connector plug form A
- With adapter G1/8 to G1/4
- To pneumatic actuators FC/FO (single acting)
- Circuit function C: de-energized closed
- Valve material: brass
- Power consumption: 24VA at AC inrush; 17VA/8W at AC hold; 8W at DC

Voltage	DN [mm]	Compressed air connec- tion P	Actuator connec- tion	PN	kv-value ($\Delta p=1$ bar) [l/min]	NBR Code
24 V=	1.5	NPT 1/8	G 1/4	10	120	199 190 554
110 V, 50-60 Hz	1.5	NPT 1/8	G 1/4	10	120	199 190 555

Accessory

Model:

- Cable plug to DIN EN 175301-803 (DIN 43 650) form A

Voltage	Version	NBR Code
0-250 V	no circuitry	199 190 540
0-24 V	with LED	199 190 541
0-24 V	with LED and varistor	199 190 542
0-24 V	with rectifier LED and varistor	199 190 543
200-240 V	with LED	199 190 544
200-240 V	with LED and varistor	199 190 545

Pilot valve type 5470

- to pneumatic actuators DA (Double acting)
- Version with NAMUR connection
- Circuit function: 4/2-way valve, in rest position pressure inlet 1 connected to outlet 2, outlet 4 exhausted
- Valve material: polyamid
- Electrical connection: cable plug

Pilot valve 4/2-ways

- For AC 50-60 Hz and DC



Voltage	DN [mm]	NBR Code	
230 V, AC/DC	4	199 190 302	
115 V, AC/DC	4	199 190 303	
24 V, AC/DC	4	199 190 304	

Pilot valve type MNL532

Model:

- With NAMUR connection and two silencers/throttle screws

Mode of action:

- 3/2-way valve, in rest position pressure inlet 1 closed, outlet 3 exhausted
- 5/2-way valve, in rest position pressure inlet 1 connected to outlet 4, outlet 3 exhausted
- Material of body: Aluminum
- to pneumatic actuators
- Electrical connection: cable plug

Pilot valve 3/2-5/2-ways



Voltage	DN [mm]	Inch	NBR Code	
230 V, AC	5	1/8	199 190 360	
110 V, AC	5	1/8	199 190 359	
48 V, AC	5	1/8	199 190 361	
24 V, AC	5	1/8	199 190 358	
24 V, DC	5	1/8	199 190 357	

Accessories to type 5470 and type MNL532

NAMUR connector plate

For DIASTAR DN15-50/PA11/21/PA30-55



Pos	DN [mm]	Series PA11/21 Code	Series PA30-55 Code	Ten/028 FC Code	Sixteen/025 FC Code	
2	15	199 190 378	199 190 275	199 190 378	199 190 378	
2	20	199 190 378	199 190 275	199 190 378	199 190 378	
2	25	199 190 378	199 190 275	199 190 378	199 190 378	
2	32	199 190 378	199 190 275	199 190 378	199 190 379	
2	40	199 190 378	199 190 275	199 190 379	199 190 379	
2	50	199 190 378	199 190 275	199 190 379	199 190 379	

table continued next page

Pos	DN [mm]	Ten/025 FO/DA Code
2	15	199 190 378
2	20	199 190 378
2	25	199 190 378
2	32	199 190 378
2	40	199 190 379
2	50	199 190 379

Solenoid pilot valve type PV2000

- Version for 3/2-way and 5/2-way valves
- Electrical control over multiple and field bus connector

2 x 3/2-way valve

Model:

- lockable manual override



No	Voltage	Code
1	24V/DC 100%	199 190 435

1 x 5/2-way valve



No	Voltage	Code
2	24 V/DC 100%	199 190 436

Connection module with D-sub connector



No	Code
3	199 190 424

End module



No	Code
4	199 190 426

Connection module AS-interface



No	Code
1	199 190 430

Connection module profibus



No	Code
1	199 190 431



Connection module with bus interface

No	Code	
2	199 190 425	

Accessories to type PV2000

Silencer 8mm

Code	
199 190 427	

Plug (white)

d [mm]	Code	
8	199 190 428	
6	199 190 429	

D-Sub connector 25 poles With connection cable

Cable length [m]	Code	
1.50	199 190 432	
3.00	199 190 433	
5.00	199 190 434	

Position indicator

For butterfly valve type 037M/038M

With electric position indicator

- Limit switch box and hand lever included

Limit switch box with 2 auxiliary switches

- Solution for PNP, NPN, NAMUR on request



d-d [mm]	DN-DN [mm]	Inch	Code	
63 - 90	50 - 80	2-3	198 151 341	
110 - 110	100 - 100	4	198 151 342	
140 - 140	125 - 125	5	198 151 343	
160 - 225	150 - 200	6-8	198 151 344	

For actuator units pneumatic type PA11 - PA90

Namur mounting flange



No	Code	
3	199 190 281	

Controllers

Digital electro-pneumatic positioner

- Other versions and accessories on request

Without feedback signal

- For actuators function FC
- For actuators function FO only possible by assembly in the factory



No	DSR 500-1 for Diastar DN 15-50 FC Code	DSR 500-2 for Diastar DN 65-150 FC Code	DSR 500-3 for pneumatic rotary actuator Code	
1	199 190 001	199 190 029	199 190 108	

With feedback signal 4-20mA

- For actuators function FC
- For actuators function FO only possible by assembly in the factory



No	DSR 500-1 for Diastar DN 15-50 FC Code	DSR 500-2 for Diastar DN 65-150 FC Code	DSR 500-3 for pneumatic rotary actuator Code	Feedback module 4-20mA Code	
1	199 190 575	199 190 576	199 190 577	199 190 109	

Accessories for digital electro-pneumatic positioner

Attachment kit to type DSR 500-1

With optical position indicator for Diastar DN 15-50

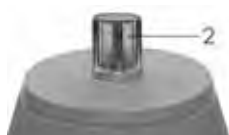

Pos	DN [mm]	Ten/028 FC Code	Sixteen/025 FC Code	Ten/025 FO Code	
2	15		199 190 417		
2	20	199 190 417	199 190 417	199 190 417	
2	25	199 190 417	199 190 418	199 190 417	
2	32	199 190 418	199 190 418	199 190 418	
2	40	199 190 418	199 190 418	199 190 418	
2	50	199 190 418	199 190 418	199 190 418	



Attachment kit to type DSR 500-1 Without optical position indicator for Diastar DN 15-50

No	DN [mm]	Ten/028 FC Code	Sixteen/025 FC Code	Ten/025 FO Code	
3	15		199 190 414		
3	20	199 190 414	199 190 414	199 190 414	
3	25	199 190 414	199 190 415	199 190 414	
3	32	199 190 415	199 190 415	199 190 415	
3	40	199 190 415	199 190 415	199 190 415	
3	50	199 190 415	199 190 415	199 190 415	



Attachment kit to type DSR 500-2 For Diastar DN 65-150

Part No.	with optical position indicator Code	without optical position indicator Code	
2	199 190 419		
3		199 190 416	



Attachement kit to type DSR 500-3 For rotary actuators

Code	
199 190 281	

Electro-pneumatic positioner Positioner type Eckardt SRI 986



No	single acting (FC/FO) Code	double acting (DA) Code	
1	199 190 348	199 190 349	

Accessories for electro-pneumatic positioner Attachment kit for type Eckardt SRI 986



No	Typ DIASTAR DN 15-150 Code	Type PA 30 - PA 90 Code	Electr. pos. transformer with 4-20mA output Code	
2	199 190 350	199 190 351	199 190 395	



Positioner mounting flange for type DIASTAR

No	DN-DN [mm]	Ten/028 FC Code	Sixteen/025 FC Code	Ten/025 FO Code
3	- 15		199 190 372	199 190 372
3	- 20	199 190 372	199 190 372	199 190 372
3	- 25	199 190 372	199 190 373	199 190 373
3	- 32	199 190 373	199 190 373	199 190 373
3	- 40	199 190 373	199 190 373	199 190 373
3	- 50	199 190 373	199 190 373	199 190 373
3	65 - 150		199 190 311	199 190 311

Industrial controller type PE70

For single loop only

Model:

- 1 sensor input
- Continuous control
- 3-point control
- L/W/H: 128/48/96



Type	Voltage	Code
PE70-3	90..250 V ~	199 192 162
PE70-4	24 V ~/ 18..30 V=	199 192 163

For ratio and single loop control

Model:

- 2 sensor inputs
- Ratio control
- Continuous control
- 3-point control
- L/W/H: 128/48/96



Type	Voltage	Code
PE70-1	90..250 V ~	199 192 160
PE70-2	24 V ~/ 18..30 V=	199 192 161

AS-Interface

AS-Interface type ASEV 2400

For electric rotary actuators

- Without accessories



Code	
199 190 562	

AS-Interface set type ASVC 2300

For pneumatic rotary actuators



Type of actuator	Code	
PA11/21 (FC/FO); PA30/35 (FC/FO)	199 190 560	
PA >35 (FC/FO)	199 190 565	
PA11/21 (DA); PA30-45 (DA)	199 190 566	
PA >45 (DA)	199 190 567	

AS-Interface set type Topmatic For Diastar

- Without accessories

Series Ten/028 FC/025 FO



DN-DN [mm]	Code	
15 - 25	199 190 456	
32 - 50	199 190 457	

Series Sixteen/025-FC



DN-DN [mm]	Code	
15 - 20	199 190 456	
25 - 32	199 190 467	
40 - 50	199 190 468	

Series 025 FC/FO



DN-DN [mm]	Code	
65 - 150	199 190 458	

AS-Interface type ASIM 2010

- Without accessories

For manual valves with integrated feedback



Code	
199 190 568	

AS-Interface type ASIM 2400

- Without accessories

For sensors with switching-output



Code	
199 190 569	

Seals

O-Ring Gasket

Model:

- Hardness approx. 65° Shore
- Suitable for union PP-N 28 51 85

EPDM 48 41 00
FPM 49 41 00

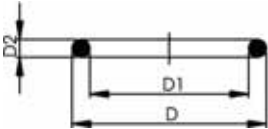

d [mm]	DN [mm]	Inch	EPDM Code	FPM Code	D [mm]	D1 [mm]	D2 [mm]
20	15	½	748 410 140	749 410 140	20	15	2.62
25	20	¾	748 410 006	749 410 006	27	20	3.53
32	25	1	748 410 025	749 410 025	32	25	3.53
40	32	1 ¼	748 410 152	749 410 152	42	31	5.34
50	40	1 ½	748 410 009	749 410 009	51	41	5.34
63	50	2	748 410 171	749 410 171	61	50	5.34

Fusion Jointing Machines

	Page
	Manual Butt and Socket Fusion Tools 612
	SG 125 Socket fusion machine 614
	SG 160 Combined Butt and Socket Fusion Machine 615
	MC 110 Butt Fusion Machine 619
	PSO 701 Butt Fusion Machine 620
	SG 315 Butt Fusion Machine 621
	IR Plus Fusion Jointing Machines 626
	BCF Plus Plastic Fusion Jointing Machine 628
	Electrofusion units and accessories 629

Manual Butt and Socket Fusion Tools

SSE Butt fusion tool



- All devices equipped with on/off switch, mains and temperature control lamp
- Choice of electronic or thermostatic temperature control
- Heating element diameter 120 mm, 200 mm and 300 mm
- The SSE 120 heater plate is bent 45°
- Pick up for floor stand or table clamp
- High-quality, non-stick PTFE-coating with long service life
- Monitoring and setting of heating element temperature
- High temperature accuracy over the entire heating surface
- T = thermostatic temperature control / E = electronic temperature control

d [mm]	Type	Performance	Code	kg
110	SSE 120 T	115 V/400 W	790 105 136	1.492
180	SSE 200 T	230 V/800 W	790 105 052	3.000
180	SSE 200 E	230 V/800 W	790 105 059	3.000
180	SSE 200 T	115 V/800 W	790 105 137	3.000
280	SSE 300 T	230 V/1500 W	790 105 053	4.780
280	SSE 300 E	230 V/1500 W	790 105 060	5.640
280	SSE 300 T	115 V/1500 W	790 105 138	5.540

SSE 200 -Set- Butt fusion tool



- All devices equipped with on/off switch, mains and temperature control lamp
- Choice of electronic or thermostatic temperature control
- Pick up for floor stand or table clamp
- High-quality, non-stick PTFE-coating with long service life
- Monitoring and setting of heating element temperature
- High temperature accuracy over the entire heating surface
- Available as a complete set in a practical metal case
- Heating element-diameter 200 mm
- Table clamp
- T = thermostatic temperature control / E = electronic temperature control

d [mm]	Type	Performance	Code	kg
180	SSE 200 T	230 V/800 W	790 105 054	7.800
180	SSE 200 E	230 V/800 W	790 105 061	7.700
180	SSE 200 T	115 V/800 W	790 105 139	8.000

SSE 300 -Set- Butt fusion tool



- All devices equipped with on/off switch, mains and temperature control lamp
- Choice of electronic or thermostatic temperature control
- Pick up for floor stand or table clamp
- High-quality, non-stick PTFE-coating with long service life
- Monitoring and setting of heating element temperature
- High temperature accuracy over the entire heating surface
- Available as a complete set in a practical metal case
- Heating element-diameter 300 mm
- Table clamp
- T = thermostatic temperature control / E = electronic temperature control

d [mm]	Type	Performance	Code	kg
280	SSE 300 T	230 V/1500 W	790 105 055	12.200
280	SSE 300 E	230 V/1500 W	790 105 062	12.500
280	SSE 300 T	115 V/1500 W	790 105 140	0.001



MSE 63/MSE 110 Socket fusion tools

- For fusion jointing of PP, PE and PVDF pipes and fittings
- Choice of electronic or thermostatic temperature control
- Support for heating bushes and spigots of d 16 to 63 mm (110 mm)
- Pick up for floor stand or table clamp
- Monitoring and setting of heating element temperature
- High temperature accuracy over the entire heating surface
- T = thermostatic temperature control / E = electronic temperature control

d-d [mm]	Type	Performance	Code	kg
16 - 63	MSE 63 T	230 V/800 W	790 105 081	1.700
16 - 63	MSE 63 E	230 V/800 W	790 105 082	1.800
16 - 63	MSE 63 T	115 V/800 W	790 105 096	2.075
16 - 110	MSE 110 T	230 V/1500 W	790 105 083	3.200
16 - 110	MSE 110 E	230 V/1500 W	790 105 084	3.200
16 - 110	MSE 110 T	115 V/1500 W	790 105 126	3.200



MSE 63/MSE 110 - Set - Socket fusion tools

- For fusion jointing of PP, PE and PVDF pipes and fittings
- All devices equipped with on/off switch, mains and temperature control lamp
- Choice of electronic or thermostatic temperature control
- Support for heating bushes and spigots of d 16 to 63 mm (110 mm)
- Pick up for floor stand or table clamp
- Monitoring and setting of heating element temperature
- High temperature accuracy over the entire heating surface
- High-quality, non-stick PTFE-coating with long service life
- Heating bushes and spigots
- Available as a complete set in a practical metal case
- Table clamp
- Floor stand for MSE 63
- Allen screws and key
- T = thermostatic temperature control / E = electronic temperature control

d-d [mm]	Type	Performance	Code	kg
16 - 63	MSE 63 T	230 V/800	790 105 085	8.700
16 - 63	MSE 63 E	230 V/800	790 105 086	8.700
16 - 63	MSE 63 T	115 V/800	790 105 098	8.600
16 - 110	MSE 110 T	230 V/1500	790 105 087	17.700
16 - 110	MSE 110 E	230 V/1500	790 105 088	16.523
16 - 110	MSE 110 T	115 V/1500	790 105 128	17.700

SG 125 Socket fusion machine

For fusion jointing of PP, PE, PB and PVDF pipes and fittings



- Portable heating element - socket fusion machine for use in the workshop and on job sites.
- Dimension 20 - 125 mm
- **Base machine**
- Compact, sturdy design, distortion-free machine bed
- Handwheel with torque locking mechanism for the slide movement
- Fast selection of insertion depth according to the pipe dimension
- **Heater**
- With electronic temperature control
- High temperature accuracy over the entire heating surface
- **Additional standard equipment on the basic model**
- Universal, left and right prismatic clamping devices, complete, for clamping pipe and fittings. Additional set of prismatic clamping devices for outer clamping of pipes available as an option.
- V-shaped pipe support d 20 - 125 mm
- Back stop
- Machine specific tool set
- Timer to clock fusion times
- Including transport packaging, without accessories

d-d [mm]	Performance	Code	kg	
20 - 125	230 V/1500 W	790 310 034	65.000	

SG 160 Combined Butt and Socket Fusion Machine

for fusion jointing PP, PE and PVDF pipes and fittings size range for butt fusion d 32 - 160



Mobile, very compact and universal plastic fusion machine for use in the workshop and on job sites.

Butt fusion d 32 - 160 mm, all pressure ratings up to PE/PP SDR 11; PVDF SDR 21.

Socket fusion d 16 - 110 mm

Base machine

- high precision, distortion-free and robust machine base
- handwheel for easy moving of machine carriage
- exact pressure adjustment via direct load transfer
- hardened, hard-chrome plated guide shafts for extreme loads
- handle for safe transport of machine
- All clamping possibilities for base clamping plates, pipe supports, back stop and prismatic clamping devices.

Planer

- planing device made of light cast aluminium
- optimised cutting geometry for even and chatter-free planing
- powerful parallel planer, swivels in and out for single or double-sided facing of pipe ends 620 W
- integrated pick up for easy mounting of calibration tools for machining of pipe ends in socket fusion

Heater

- high-performance and precision heater with electronic temperature control 1500 W
- high accuracy of +/- 4°C over the entire heating surface
- heater temperature can be set exactly with digital LCD
- high quality, non-stick, easy to change PTFE fabric

Additional standard equipment on the basic model

- V-shaped pipe supports d 16 - 160 mm for fittings
- timer to clock fusion times
- tool set specified to machine
- Including transport packaging, without accessories

d-d [mm]	Performance	Code	kg
16 - 160	230 V	790 103 031	44.900
16 - 160	115 V	790 103 033	45.000

Special transport crate



Code	kg
790 103 099	108.000



Base clamping plates

- In order to improve the quality of the fusion joint, and for reliable clamping of long pipes, we recommend using the maximum number of clamping devices.
- For welding of long pipes we recommend to use the outer left and outer right base clamping plates as well.
- L = left
- R = right

d [mm]	Type	Code	kg
160	L	790 103 010	2.508
160	R	790 103 011	2.549



Inserts, left/right

- For base clamping plate or bracket
- Left or right

d [mm]	Code	kg
32	790 103 019	0.315
40	790 103 020	0.303
50	790 103 021	0.302
63	790 103 022	0.277
75	790 103 023	0.250
90	790 103 024	0.219
110	790 103 025	0.178
125	790 103 026	0.132
140	790 103 027	0.079



Clamping bracket, left/right

- For base clamping plate or bracket
- L = left
- R = right

* Threaded clamping bracket, for mounting inserts d 32 - 140 mm. An additional insert must be used instead of clamping brackets d 32 - 140 mm, i.e. twice the number of inserts listed must be ordered.

d [mm]	Type	Code	kg
32	L	790 103 039	1.076
40	L	790 103 040	0.530
50	L	790 103 041	0.537
63	L	790 103 042	0.531
75	L	790 103 043	0.530
90	L	790 103 044	0.580
110	L	790 103 045	0.580
125	L	790 103 046	0.606
140	L	790 103 047	0.650
* 160	L	790 103 048	0.669
32	R	790 103 059	0.530
40	R	790 103 060	0.530
50	R	790 103 061	0.530
63	R	790 103 062	0.530
75	R	790 103 063	1.042
90	R	790 103 064	1.174
110	R	790 103 065	0.590
125	R	790 103 066	0.605
140	R	790 103 067	0.530
* 160	R	790 103 068	0.679



Prismatic clamping device

- Prismatic clamping device for pick up of clamping jaws for exact alignment of fusion components
- L = left
- R = right

*Horizontal adjustable

Type	Code	kg	
L	790 103 080	5.849	
R	790 103 081	5.839	



Clamping jaws

d	Code	kg	
16-32 / 90-110	790 103 085	0.310	
30-50 / 50-90	790 103 086	0.330	

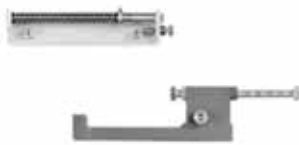

Depth stop, complete

Code	kg	
790 103 090	0.610	



Heating spigots and bushes

d [mm]	Code	kg	
16	790 101 086	0.310	
20	790 101 087	0.315	
25	790 101 088	0.313	
32	790 101 089	0.316	
40	790 101 090	0.330	
50	790 101 091	0.475	
63	790 101 092	0.858	
75	790 101 093	1.157	
90	790 101 094	1.697	
110	790 101 095	2.090	



Stiffener plate

d [mm]	Code	kg	
110	790 101 098	0.264	



Calibration tool

- For mechanical, standardised calibration of pipe ends in PE, PP and PVDF (to be used with planer)
- easy and time-saving removal of oxide layer
- Consistent peeling quality over the entire pipe circumference

d [mm]	Code	kg	
20	790 103 160	0.950	
25	790 103 161	0.950	
32	790 103 162	0.950	
40	790 103 163	0.930	
50	790 103 164	0.950	
63	790 103 165	1.000	
75	790 103 166	1.150	
90	790 103 167	1.250	
110	790 103 168	1.344	

MC 110 Butt Fusion Machine

Machine MC 110, with electric planer, thermostatic heater



- Portable butt fusion machine for use in the workshop and on job sites. For fusion jointing of PP and PE pipes and fittings as well as prefabrication of segments in the size range d 20 - 110 mm and up to SDR 11.
- Machine MC 110 complete includes: machine mounting, base machine, 2 base clamping plates (wide), base clamping plate (left narrow), electrically operated planer, thermostatic controlled heater, table clamp and transport box.
- Including transport packaging, without accessories

d-d [mm]	Performance	Code	kg
20 - 110	230V/1360W	790 109 303	31.000
20 - 110	115V/1360W	790 109 321	31.000



Reduction clamping inserts, wide

- 20 - 90 mm
- Each code number defines 1 half shell. Per wide base clamping plate 2 reduction half-shells are needed.

d [mm]	Code	kg
25	790 109 327	0.139
32	790 109 328	0.133
40	790 109 329	0.130
50	790 109 330	0.113
56	790 109 342	0.137
63	790 109 331	0.120
75	790 109 332	0.111
90	790 109 333	0.100



Reduction clamping inserts, narrow

- Each code number defines 1 half shell. Per wide base clamping plate 2 reduction half-shells are needed.

d [mm]	Code	kg
25	790 109 335	0.279
32	790 109 336	0.136
40	790 109 337	0.258
50	790 109 338	0.239
56	790 109 343	0.115
63	790 109 339	0.108
75	790 109 340	0.193
90	790 109 341	0.148

PSO 701 Butt Fusion Machine

For fusion jointing of PP and PE pipes and fittings, size range d 40 - 160 mm



- Compact and mobile butt fusion machine for PE and PP pipes for the use in the workshop and on the building site. Perfect for sanitary installations and wastepipes. The wooden box is usable as working bench as well as for transportation
- Pressure adjustment via direct load transfer (max. force 100 kp). SDR 11 d 160 mm (PE and PP)
- Planer and heating element could be swivelled in and out
- High performance heating element thermostatic controlled (PTFE coated)
- The heating element can be used as manual fusion tool
- **V-shaped pipe support** with inserts d 40 - 140 mm
- **Reduction clamping inserts** d 40 - 140 mm
- **Base clamping plates** right and left, d 160 mm
- Machine specific tool set

d-d [mm]	Performance	Code	kg	
40 - 160	230 V/1360 W	790 301 000	95.500	

SG 315 Butt Fusion Machine

SG 315 for butt fusion jointing of PP, PE and PVDF pipes and fittings



The industrial butt fusion machine for pressure piping systems. Extremely sturdy design use in the workshop and on job sites.

Sizes d 90-315 mm, all pressure ratings up to max. PE d 280 SDR 11; PP d 280 SDR 7.25 and PVDF d 315 SDR 21.

Base machine

- high precision, distortion-free and robust machine base
- handwheel for easy moving of machine carriage
- fusion pressure is maintained with a user friendly torque limiter
- exact pressure adjustment via direct load transfer
- hardened, hard-chrome plated guide shafts for extreme loads
- handle for safe transport of machine
- optional outer, horizontally removeable clamping devices available

Planer

- optimised cutting geometry for even and chatter-free planing
- powerful parallel planer, swivels in and out for single or double-sided facing of pipe ends, 1100 W
- for your personal safety, a safety switch has been integrated to prevent unintentional start-up in the working position

Heater

- high-performance and precision heater with electronic temperature control 1700 W
- high accuracy of +/- 4°C over the entire heating surface
- heater temperature can be set exactly with digital LCD
- high quality, non-stick, easy to change PTFE coating
- with digital temperature indicator

Additional standard equipment included in the base model

- inner left and right clamping plates, d 315 mm, for pick up of reduction clamping inserts d 90 - 280 mm
- pipe supports d 315 mm for support of fittings
- timer to clock fusion times
- tool set specified to machine
- Including transport packaging, without accessories

d-d [mm]	Performance	Code	kg	
90 - 315	115 V	790 130 002	128.000	



SG 315 for butt fusion jointing of PP, PE and PVDF pipes and fittings

The industrial butt fusion machine for pressure piping systems. The S-version (S = segment) additionally allows prefabrication of segments. Sizes d 90-315 mm, all pressure ratings up to max. PE d 280 SDR 11; PP d 280 SDR 7.25 and PVDF d 315 SDR 21.

Base machine

- integrated swivel tables for equalization of wall offset transverse to axial direction, for segment fusion up to 30°
- optional outer, horizontally removeable clamping devices available
- high precision, distortion-free and robust machine base
- handwheel for easy moving of machine carriage
- fusion pressure is maintained with a user friendly torque limiter
- exact pressure adjustment via direct load transfer
- hardened, hard-chrome plated guide shafts for extreme loads
- handle for safe transport of machine

Planer

- optimised cutting geometry for even and chatter-free planing
- powerful parallel planer, swivels in and out for single or double-sided facing of pipe ends, 1100 W
- for your personal safety, a safety switch has been integrated to prevent unintentional start-up in the working position

Heater

- high-performance and precision heater with electronic temperature control 1700 W
- high accuracy of +/- 4°C over the entire heating surface
- heater temperature can be set exactly with digital LCD
- high quality, non-stick, easy to change PTFE coating
- with digital temperature indicator

Additional standard equipment included in the base model

- inner left and right clamping plates, d 315 mm, for pick up of reduction clamping inserts d 90 - 280 mm
- pipe supports d 315 mm for support of fittings
- timer to clock fusion times
- tool set specified to machine
- Including transport packaging, without accessories

d-d [mm]	Performance	Code	kg
90 - 315	230 V	790 130 003	150.000
90 - 315	115 V	790 130 004	143.000



SG 315 for butt fusion jointing of PP, PE and PVDF pipes and fittings

The industrial butt fusion machine for pressure piping systems. Extremely sturdy design for use in the workshop and on job sites.

Equipped with a load cell and a digital display of the fusion force.

Sizes d 90-315 mm, all pressure ratings up to max. PE d 280 SDR 11;
PP d 280 SDR 7.25 and PVDF d 315 SDR 21.

Base machine

- high precision, distortion-free and robust machine base
- handwheel for easy moving of machine carriage
- fusion pressure is maintained with a user friendly torque limiter
- exact pressure adjustment via direct load transfer
- hardened, hard-chrome plated guide shafts for extreme loads
- handle for safe transport of machine
- digital display
- optional outer, horizontally removeable clamping devices available

Planer

- optimised cutting geometry for even and chatter-free planing
- powerful parallel planer, swivels in and out for single or double-sided facing of pipe ends, 1100 W
- for your personal safety, a safety switch has been integrated to prevent unintentional start-up in the working position

Heater

- high-performance and precision heater with electronic temperature control 1700 W
- high accuracy of +/- 4°C over the entire heating surface
- heater temperature can be set exactly with digital LCD
- high quality, non-stick, easy to change PTFE coating
- with digital temperature indicator

Additional standard equipment included in the base model

- inner left and right clamping plates, d 315 mm, for pick up of reduction clamping inserts d 90 - 280 mm
- pipe supports d 315 mm for support of fittings
- timer to clock fusion times
- tool set specified to machine
- Including transport packaging, without accessories

d-d [mm]	Performance	Code	kg
90 - 315	230 V	790 130 031	150.000
90 - 315	115 V	790 130 032	128.000



SG 315 for butt fusion jointing of PP, PE and PVDF pipes and fittings

The industrial butt fusion machine for pressure piping systems. The S-version (S = segment) additionally allows prefabrication of segments. Sizes d 90-315 mm, all pressure ratings up to max. PE d 280 SDR 11; PP d 280 SDR 7.25 and PVDF d 315 SDR 21.

Base machine

- integrated swivel tables for equalization of wall offset transverse to axial direction, for segment fusion up to 30°
- optional outer, horizontally removeable clamping devices available
- high precision, distortion-free and robust machine base
- handwheel for easy moving of machine carriage
- fusion pressure is maintained with a user friendly torque limiter
- exact pressure adjustment via direct load transfer
- hardened, hard-chrome plated guide shafts for extreme loads
- handle for safe transport of machine
- load cell
- digital display

Planer

- optimised cutting geometry for even and chatter-free planing
- powerful parallel planer, swivels in and out for single or double-sided facing of pipe ends, 1100 W
- for your personal safety, a safety switch has been integrated to prevent unintentional start-up in the working position

Heater

- high-performance and precision heater with electronic temperature control 1700 W
- high accuracy of +/- 4°C over the entire heating surface
- heater temperature can be set exactly with digital LCD
- high quality, non-stick, easy to change PTFE coating
- with digital temperature indicator

Additional standard equipment included in the base model

- inner left and right clamping plates, d 315 mm, for pick up of reduction clamping inserts d 90 - 280 mm
- pipe supports d 315 mm for support of fittings
- timer to clock fusion times
- tool set specified to machine
- Including transport packaging, without accessories

d-d [mm]	Performance	Code	kg
90 - 315	230 V	790 130 033	143.000
90 - 315	115 V	790 130 034	145.000



Reduction clamping inserts, narrow

- d 90 - 280 mm
- Each code number represents 1 piece of reduction clamping insert. Per machine and dimension maximum 8 narrow or wide reduction clamping inserts are needed.
- We recommend 4 wide and 4 narrow half shells.

d [mm]	Code	kg	
90	790 112 098	1.265	
110	790 112 099	1.220	
125	790 112 100	1.215	
140	790 112 101	1.139	
160	790 112 102	1.080	
180	790 112 103	1.006	
200	790 112 104	0.945	
225	790 112 105	0.833	
250	790 112 106	0.712	
280	790 112 107	0.562	

IR Plus Fusion Jointing Machines

IR-63 Plus Fully-Equipped Machine



Model:

- Fully-equipped fusion jointing machine for welding SYGEF Standard, SYGEF Plus, PROGEF Standard, PROGEF Natural, PROGEF Plus, PE 100, PFA in dimensions d 20-63 mm with integrated remote welding unit, 2 USB interfaces, monochrome display with icons and 12 languages.
- 1-phase AC (50/60 Hz) 230 V L/N/PE
- Machine housing complete (1 pcs.)
- Heater assembly (1 pcs.)
- Remote weld device (1 pcs.)
- Facing tool (1 pcs.)
- Transport box (1 pcs.)
- Pipe stop (1 pcs.)
- Clamping inserts d 20-63 mm (8 pcs. per dimension)
- End caps PE d 20-63 mm (4 pcs. per dimension)
- Power supply cable 230 V (1 pcs.)
- Extension cable for remote weld device (1 pcs.)
- Extension cable for heater (1 pcs.)
- Extension cable for facing tool (1 pcs.)
- Cleaning brush No. 8 (1 pcs.)
- Hexagon key 3 mm (1 pcs.)
- Hexagon key 4 mm (1 pcs.)
- Heater protection shield (1 pcs.)
- Clamping unit extension (8 pcs.)
- Socket wrench (facing blades) (1 pcs.)
- Screw driver, Size 0 (1 pcs.)
- Accessory Tray (1 pcs.)
- Manual (1 pcs.)

d-d [mm]	Code	kg	
20 - 63	790 131 005	35.000	

IR-110 Plus Fully-Equipped Machine



Model:

- Fully-equipped fusion jointing machine for welding SYGEF® Standard, SYGEF® Plus, PROGEF® Standard, PROGEF® Natural, PROGEF® Plus, PE 100, PFA, ECTFE in dimensions d 20-110 mm, 2 USB interfaces, monochrome display with icons and 12 languages.
- 1-phase AC (50/60 Hz) 230 V L/N/PE
- Machine housing complete (1 pcs.)
- Heater and facing tool assembly (1 pcs.)
- Transport box (1 pcs.)
- Pipe stop (1 pcs.)
- Clamping inserts d 20-90 mm (8 pcs. per dimension)
- End caps PE d 20-110 mm (4 pcs. per dimension)
- Power supply cable 230 V (1 pcs.)
- Cleaning brush No. 8 (1 pcs.)
- Hexagon keys 4 mm (1 pcs.), 5 mm (1 pcs.), 6 mm (1 pcs.)
- Socket wrench (facing blades) (1 pcs.)
- Accessory Tray (1 pcs.)
- Manual (1 pcs.)

d-d [mm]	Code	kg	
20 - 110	790 132 001	75.000	



IR-225 Plus Fully-Equipped Machine with HP Working Table (HP = High Purity)

Model:

- Fully-equipped fusion jointing machine for welding SYGEF Standard, SYGEF Plus, PROGEF Standard, PROGEF Natural, PROGEF Plus, PE 100 in dimensions d 63-225 mm, 2 USB interfaces, monochrome display with icons and 12 languages.
- 1-phase AC (50/60 Hz) 230 V L/N/PE or 3-phase AC (50/60 Hz) 400 V/230 VL1/L2/L3/N/PE
- Machine base (1 pcs.)
- Facing tool (1 pcs.)
- Heater assembly (1 pcs.)
- Working table, HP (1 pcs.)
- Movable clamping units (1 pcs.)
- Clamping inserts d 63-225 mm (8 pcs. per dimension)
- End caps PE d 63-225 mm (4 pcs. per dimension)
- Transportation lock (1 pcs.)
- Pipe stop (1 pcs.)
- Hexagon key 5 mm (1 pcs.)
- Hexagon key 6 mm (1 pcs.)
- Combination ring /open-jaw wrench 13 mm (1 pcs.)
- Cleaning brush (1 pcs.)
- Connecting cable 400 V - 230 V (1 pcs.)
- Ball for lever (1 pcs.)
- Manual (1 pcs.)

d-d [mm]	Code	kg	
63 - 225	790 133 009	453.000	

BCF Plus Plastic Fusion Jointing Machine

BCF Plus fully equipped machine d 20 - 63 mm



Fully-equipped machine for bead and crevice free jointing of SYGEF Standard, SYGEF Plus, PROGEF Natural of the dimensions d 20-63 mm with integrated remote welding unit, 2 USB interfaces, monochrome display with icons and 12 languages.

Supply:

1-phase AC (50/60 Hz) 115 / 230 V L/N/PE

Delivery includes:

- Machine housing (1 pcs.) incl. remote welding unit (1 pcs.)
- Transport box (1 pcs.)
- HP working table (1 pcs.)
- Heating stations d 20-63 mm (6 pcs.)
- Clamping units small (2 pcs.) with clamping inserts d 20-63 mm (24 pcs.)
- Facing tool small (1 pcs.) with facing inserts d 20-63 mm (6 pcs.)
- Facing tool support (1 pcs.)
- Hose box (1 pcs.) incl. air hose (1 pcs.)
- Supporting tools small d 20-63 mm (2 pcs.)
- BReT (1 pcs.)
- Hose cutter (1 pcs.)
- Air hose reducer (6-4 mm) (1 pcs.), air hose socket (4-4 mm) (1 pcs.)
- Extension cable (1 pcs.)
- Manual (1 pcs.)

d-d [mm]	Code	kg	
20 - 63	790 121 002	153.000	



BCF Plus Bladder

- Only suitable for welding PROGEF® Natural. **Blue bladder head!**

d [mm]	Code	kg	Pieces	
20	790 122 091	0.038	1	
25	790 122 092	0.021	1	
32	790 122 093	0.040	1	
40	790 122 094	0.050	1	
50	790 122 095	0.105	1	
63	790 122 096	0.138	1	

Electrofusion units and accessories

MSA Plus 400

Traceability electrofusion unit With USB interfaces



NEW, environmentally friendly manufactured Electrofusion unit in accordance with EU directive 2002/95/EU (RoHS).

Professional Electrofusion unit for traceability of piping system components from raw material to completed Electrofusion joint (in accordance with ISO 12176). The MSA units with the unique inverter technology and the active cooling system for trouble-free operation from generator or mains supply. Suitable for jointing in series. The unit is equipped with compact flash memory card (exchangeable data carrier) and either a barcode reader pen or barcode scanner. The unit is robust, light and easy to use. The menu has up to 27 different languages. Scope of delivery includes: 1 transport case, 1 USB memory stick, 1 pair of angle adapter clips 4.0 mm, operating instructions, configuration card and Software MSA WIN-WELD.

For printer or PC communication, the USB cable (799350619) is required.

Technical Data

Ambient temperature	-10 °C to +45 °C
Mains voltage	180 V - 264 V AC
Mains frequency	45Hz - 65 Hz
Fusion voltage	8 - 42 (48) V AC
Fusion current	max. 80 A
Power	max. 3500 W
Protection	1 / IP 65
Interfaces	USB (type A) for printer communication and to load software updates USB (type B) for PC communication
Mains cable	3 m
Fusion cable	3 m
Dimensions (WxHxD)	284 x 440 x 195 mm
Weight incl. cables	ca. 11,5 kg, light-weight aluminium housing
Display	LCD graphic, background light, contrast adjustment
Size display (WxH)	132 x 39 mm
Type size	8 mm
Languages	Brasilian, Bulgarian, Chinese, Croatian, Czech, Danish, Dutch, English, Estonian, Finnish, French, German, Hungarian, Italian, Korean, Latvian, Lithuanian, Macedonian, Malaysian, Norwegian, Polish, Portuguese, Romanian, Russian, Slovakian, Slovenian, Spanish, Swedish, Turkish
Warranty	24 months

Type	Code	kg	Description
MSA Plus 400	799 350 580	15.784	barcode reader pen, transport case
MSA Plus 400	799 350 581	15.926	barcode scanner, transport case
MSA Plus 400	799 350 585	16.800	CH power plug with barcode reader pen, transport case



MSA Plus 350 Record electrofusion unit With USB interfaces

NEW, environmentally friendly manufactured Electrofusion unit in accordance with EU directive 2002/95/EU (RoHS).

Professional Electrofusion unit for recording jointing data of Electrofusion components as a basis for electronic joint recording. The MSA units with the unique inverter technology and the active cooling system for trouble-free operation from generator or mains supply. Suitable for jointing in series. The unit is equipped with either a barcode reader pen or with barcode scanner. The unit is robust, light and easy to use. The menu has up to 27 different languages. Scope of delivery includes: transport box, 1 USB memory stick, 1 pair of angle adapter clips 4.0 mm, operating instructions, configuration card and Software MSA WIN-WELD.

To read out the fusion protocols, either the USB cable (799 350 619) or the USB memory stick (799 350 622) is required.

Technical Data

Ambient temperature	-10 °C to +45 °C
Mains voltage	180 V - 264 V AC
Mains frequency	45Hz - 65 Hz
Fusion voltage	8 - 42 (48) V AC
Fusion current	max. 80 A
Power	max. 3500 W
Protection	1 / IP 65
Interfaces	USB (type A) for printer communication and to load software updates USB (type B) for PC communication
Mains cable	3 m
Fusion cable	3 m
Dimensions (WxHxD)	284 x 440 x 195 mm
Weight incl. cables	ca. 11,5 kg, light-weight aluminium housing
Display	LCD graphic, background light, contrast adjustment
Size display (WxH)	132 x 39 mm
Type size	8 mm
Languages	Brasilian, Bulgarian, Chinese, Croatian, Czech, Danish, Dutch, English, Estonian, Finnish, French, German, Hungarian, Italian, Korean, Latvian, Lithuanian, Macedonian, Malaysian, Norwegian, Polish, Portuguese, Romanian, Russian, Slovakian, Slovenian, Spanish, Swedish, Turkish
Warranty	24 months

Type	Code	kg	Description
MSA Plus 350	799 350 570	14.500	barcode reader pen, transport case
MSA Plus 350	799 350 571	15.852	barcode scanner, transport case
MSA Plus 350	799 350 575	15.679	CH Power plug, with barcode reader, transport case



MSA Plus 300 Automatic electrofusion unit With USB interfaces

NEW, environmentally friendly manufactured Electrofusion unit in accordance with EU directive 2002/95/EU (RoHS).

Automatic Electrofusion unit with barcode reader pen, optional with barcode scanner. The MSA units with the unique inverter technology and the active cooling system for trouble-free operation from generator or mains supply. Suitable for jointing in series. The unit is robust, light and easy to use. The menu has up to 27 different languages. Scope of delivery includes: transport box, 1 pair of angle adapter clips 4.0 mm, operating instructions and configuration card.

To load software updates the USB memory stick (799 350 622) is required.

Technical Data

Ambient temperature	-10 °C to +45 °C
Mains voltage	180 V - 264 V AC
Mains frequency	45Hz - 65 Hz
Fusion voltage	8 - 42 (48) V AC
Fusion current	max. 80 A
Power	max. 3500 W
Protection	1 / IP 65
Interfaces	USB (type A) to load software updates USB (type B) for PC communication
Mains cable	3 m
Fusion cable	3 m
Dimensions (WxHxD)	284 x 440 x 195 mm
Weight incl. cables	ca. 11,5 kg, light-weight aluminium housing
Display	LCD graphic, background light, contrast adjustment
Size display (WxH)	132 x 39 mm
Type size	8 mm
Languages	Brasilian, Bulgarian, Chinese, Croatian, Czech, Danish, Dutch, English, Estonian, Finnish, French, German, Hungarian, Italian, Korean, Latvian, Lithuanian, Macedonian, Malaysian, Norwegian, Polish, Portuguese, Romanian, Russian, Slovakian, Slovenian, Spanish, Swedish, Turkish
Warranty	24 months

Type	Code	kg	Description
MSA Plus 300	799 350 560	15.797	barcode reader pen, transport case
MSA Plus 300	799 350 561	15.737	barcode scanner, transport case
MSA Plus 300	799 350 565	15.508	CH Power plug, with barcode reader pen, transport case



Adapter

- Adapters for Electrofusion units with 4 mm connectors.
- Compatible with electrofusion units MSA 210-230, MSA 330-340, MSA 250 – 400, MSA 250 – 400 PLUS.

Type	Code	kg	Description
4,0 mm	799 350 340	0.058	Angle adapter, black
4,7 mm	799 350 341	0.057	Angle adapter, grey
4,0 mm	799 350 461	0.014	Adapter, black
4,7 mm	799 350 462	0.014	Adapter, white



Rotary Peeler RS

This innovative Rotary Peeler RS is designed for universal peeling at the pipe end for electrofusion couplings, tees and elbows and as well as for electrofusion saddles. Suitable for peeling PE80, PE100, PEX and PP pipes.

Features and your advantage:

Spring loaded peeling blade:Peeling quality independent of pipe ovality or tolerances

Pivoted mounted peeling blade:To compensate the shape of coiled pipe

Optimized cutting geometry:Defined chip thickness with cutting width overlap

One tool per dimension:Minimized swivel radius for peeling in narrow locations

Peeling length:No limitation of peeling length

Guidance rolls:3-point-support for dimensional optimized cutting feed

Time saving:Tool is always ready for use, it can be used for the next peeling without having to set the peeling blade back in its origin position

Your advantage:Time saving and highest repeatable peeling quality at smallest rotation radius. No operator errors possible when changing dimension

Included:1 x Rotary Peeler RS, Transport case, Operating manual, Spare parts list

Article	d [mm]	Code	kg
RS 40	40	790 136 001	1.310
RS 50	50	790 136 002	1.310
RS 63	63	790 136 003	1.310
RS 75	75	790 136 004	1.540
RS 90	90	790 136 005	1.540
RS 110	110	790 136 006	1.540
RS 125	125	790 136 007	1.730
RS 140	140	790 136 008	1.730
RS 160	160	790 136 009	1.730
RS 180	180	790 136 010	2.030
RS 200	200	790 136 011	2.030
RS 225	225	790 136 012	2.030
RS 250	250	790 136 013	2.440
RS 280	280	790 136 014	2.440
RS 315	315	790 136 015	2.440

9 300 725



Peeling Tool PT 1 E

- The rotating Peeling Tool PT 1 E is suitable for preparing pipe ends with diameters d 20 - 90 mm (when installing Electrofusion couplers and fittings). The tool ensures a constant peeling quality on the complete peeling surface and is suitable for PE80, PE100 and PEX.
- Scope of delivery: 1 basic tool in a plastic carrying case, without pipe inserts. The case has sufficient space for approximately 6 pipe inserts.

d-d [mm]	Code	kg	Description
20 - 90	799 150 382	2.261	Basic Tool PT 1 E

9 300 725



Pipe Inserts for Peeling Tool PT 1 E

d [mm]	e [mm]	Code	kg	Description
20	1.9	799 300 739	0.220	Pipe Insert SDR 11
20	3.0	799 300 741	0.220	Pipe Insert SDR 7
25	2.3	799 300 740	0.230	Pipe Insert SDR 11
25	3.0	799 300 742	0.230	Pipe Insert SDR 9
32	3.0	799 300 743	0.230	Pipe Insert SDR 11
40	3.7	799 300 744	0.230	Pipe Insert SDR 11
50	4.6	799 300 745	0.350	Pipe Insert SDR 11
63	3.8	799 300 725	0.475	Pipe Insert SDR 17
63	5.8	799 300 746	0.475	Pipe Insert SDR 11
75	4.5	799 300 727	0.601	Pipe Insert SDR 17
75	6.9	799 300 747	0.601	Pipe Insert SDR 11
90	5.4	799 300 748	0.834	Pipe Insert SDR 17
90	8.2	799 300 749	0.220	Pipe Insert SDR 11

9 300 750



Peeling Tool PT 2

- The rotating Peeling Tools PT 2 are suitable for preparing pipe ends (when installing Electrofusion couplers and fittings). The tool ensures a constant peeling quality on the complete peeling surface and is suitable for PE80, PE100 and PEX pipes.
- Scope of delivery: 1 tool (size 1, 2 or 3) in a metal carrying case.

d-d [mm]	Code	kg	Description
90 - 250	799 300 753	6.973	Size 1, peeling length 140 mm
110 - 400	799 300 755	9.900	Size 2, peeling length 150 mm
110 - 500	799 300 756	3.900	Size 3, peeling length 175 mm

9 300 700



Peeling Tool PT 4

- The easy-to-use peeling tools PT 4 are suitable for preparing pipe ends (when installing Electrofusion couplers and fittings). The tools ensure a constant peeling quality on the whole peeled area and are suitable for PE80 and PE100 pipes. There is no tool service arrangement for the PT 4.
- Scope of delivery: 1 tool with exchangeable blade (4 cutting surfaces).

e [mm]	d [mm]	Code	kg	Description
1.9	20	799 300 704	0.271	Pipe Insert SDR 11
3.0	20	799 300 705	0.255	Pipe Insert SDR 7
2.3	25	799 300 706	0.308	Pipe Insert SDR 11
3.0	25	799 300 707	0.290	Pipe Insert SDR 9
3.0	32	799 300 708	0.340	Pipe Insert SDR 11
3.7	40	799 300 709	0.380	Pipe Insert SDR 11
4.6	50	799 300 710	0.436	Pipe Insert SDR 11
5.8	63	799 300 711	0.540	Pipe Insert SDR 11

9 301 475



Double Clamp

- The user-friendly Double Clamps are suitable for coupler connections. They are quickly and easily put into position and prevent pullout and pipe movements during the fusion time and cooling time.
- Scope of delivery: 1 tool consisting of 1 beam (compact), 2 V-clamps complete with ratchet and belt.



d-d [mm]	Code	kg
63 - 125	799 301 484	3.506
110 - 225	799 301 486	7.918
225 - 500	799 301 488	14.735

9 301 450



Quadruple Clamp

- The professional Quadruple Clamps are suitable for coupler connections. They are quickly and easily put into position and ensure a stress-free fusion. They prevent pull-out and pipe movements during the fusion and cooling times.
- Recommended for difficult site conditions with large installation-induced stresses.
- Scope of delivery: 1 tool consisting of 1 beam (long), 4 V-clamps complete with ratchet and belt.

d-d [mm]	Code	kg	
63 - 125	799 301 459	7.142	
110 - 225	799 301 461	16.490	
225 - 500	799 301 463	28.500	

9 301 525



Twin Clamp

- The easy-to-use Twin Clamp is suitable for coupler connections on straight or coiled pipe. The clamps prevent pullout and pipe movements during the fusion and cooling time.
- Scope of delivery: 1 complete tool.

d [mm]	Code	kg	
20	799 301 536	0.498	
25	799 301 537	0.471	
32	799 301 538	0.756	
40	799 301 539	0.876	
50	799 301 540	1.167	
63	799 301 541	1.438	

9 301 575



Multi Clamp

- This tool is quick and easy to use and is suitable for straight forward connections to straight lengths of pipe or saddle branch outlets with electrofusion couplers.
- Scope of delivery: 1 tool without accessories.

d-d [mm]	Code	kg	
20 - 63	799 301 575	1.409	

9 301 575



Inserts for Multi Clamp

d-d [mm]	Code	kg	Description	
25 - 20	799 150 385	0.488	Inserts, Sets	
32 - 20	799 150 386	0.500	Inserts, Sets	
32 - 25	799 150 387	0.520	Inserts, Sets	
40 - 32	799 150 388	0.500	Inserts, Sets	
50 - 40	799 150 389	0.500	Inserts, Sets	
63 - 32	799 150 390	0.520	Inserts, Sets	
63 - 40	799 150 391	0.520	Inserts, Sets	
63 - 50	799 150 392	0.520	Inserts, Sets	



Clamping device Topload 315

- This clamp and mounting tool is used for top-load Saddles on pipes of dimensions d 280 - 400 mm.
- Scope of delivery: 1 base mounting clamp, 1 bracket, 2 clamping screws, 2 ratchet scraps, 1 transport box

d-d [mm]	Code	kg	
280 - 400	799 350 475	10.010	



Clamping device topload 400

- This clamp and mounting tool is used for top-load Saddles on pipes of dimensions d 280 - 400 mm.
- Scope of delivery: 1 base mounting clamp, 1 bracket, 2 clamping screws, 2 ratchet scraps, 1 transport box

d-d [mm]	Code	kg	
280 - 400	799 350 475	10.010	



Clamping device topload 630

- This clamp and mounting tool is used for top-load Saddles on pipes of dimensions d 280 - 400 mm and branch fittings for dimensions d 280 mm – 630 mm.
- Scope of delivery: 1 base mounting clamp, 1 clamping attachment, 1 bracket, 2 clamping screws, 2 ratchet scraps, 1 transport box

d-d [mm]	Code	kg	
280 - 630	799 350 477	35.000	



Clamping attachment topload 630

- Clamping attachment as single part for extension of Topload tool 400 (799 350 475)
- Suitable for Branch fittings dimension d 280 mm – 630 mm

d-d [mm]	Code	kg	
280 - 630	799 350 476	5.000	

9 150 090



Spring Clamp for ELGEF® 24 V Reinforcing Saddles

- The Spring Clamp is used to install ELGEF® 24 V reinforcing saddles d 40 - 225 mm. The tool ensures a constant jointing pressure during the entire fusion cycle.

d-d [mm]	Code	kg	
40 - 225	799 150 090	1.180	



Assembly and Tapping Key for ELGEF® Plus Saddles

Type	Code	kg	Description	
8/10/17	799 198 047	0.798	For all saddles	



Tapping Key for ELGEF® Plus Saddles

- With adjustable tapping depth.

Type	Code	kg	Description
10	799 198 080	0.114	for Monobloc d 40 mm and d 50 mm
17	799 198 079	0.556	for Monobloc d 63 mm, d 90 - 160 mm and all Duobloc saddles
12.7	799 198 091	0.543	for socket with cutter



Hexagon Key for ELGEF® Plus Saddles and Branch Fittings

Type	Code	kg	Description
SW8	799 150 378	0.129	For all saddles and branch fittings



Tapping Adapter for ELGEF® Plus Saddles

- The Adapter is used for gas-free tapping under pressure. Type S 54 for tapping saddles with rotatable outlet d 20 - 40 mm (Tapping Tee d 32 mm). Type S 67 for tapping saddles with rotatable outlet d 50 - 63 mm (Tapping Tee d 63 mm).

Type	Code	kg	Description
S 54	799 100 061	0.785	for Tapping Tee d 32 mm
S 67	799 100 062	1.011	for Tapping Tee d 63 mm



Pressure Test Cap for ELGEF® Plus Tapping Saddles

- The cap has a Rp 3/8" connection thread and is made from galvanised steel.
- **Overview of Tapping Adapter types and Pressure Test Cap**
- M For Monobloc d 40 and 50 mm (outlets d 20 - 32 mm)
- S 54 For all saddles with rotatable outlet (outlets d 20 - 40 mm) i.e. Tapping Tee d 20 - 40 mm.
- S 67 For all Saddles with rotatable outlet (outlets d 50 and 63 mm) i.e. Tapping Tee d 63 mm.

Type	Code	kg	Description
M	799 199 282	0.116	for Monobloc d 40 mm and d 50 mm
S 54	799 199 283	7.142	for Tapping Tee d 20 - 40 mm
S 67	799 199 286	0.430	for Tapping Tee outlet d 63 mm



Cutter for PE Pipes

- This cutter is suitable for PE pipes and can be used on pipes of up to d 225 mm with a wall thickness of up to 21 mm.

d [mm]	Code	kg	Description
39	799 198 012	0.215	accessories Basic Tool Box



PE Repair Plug

- PE Repair Plugs are suitable for use with ELGEF® 24 V PE Reinforcement Saddles 53 127 000.

d [mm]	Code	kg	Description
30	799 199 088	0.012	
39	799 199 089	0.019	



Hexagon Key for PVC Saddles

- The Hexagon Key is suitable for tapping water and gas mains under pressure.
- Scope of delivery: 1 hexagon key, protective cover, without rotating pin.

d-d [mm]	Code	kg	s [mm]	G [inch]	
16 - 25	799 150 007	0.342	19	30	
32 - 40	799 150 008	0.496	27	38	
50 - 63	799 150 009	0.690	27	47	

Accessories and Tools for Welding Machines

Heating Spigots and Bushes



- High-quality, non-stick PTFE-coating with long service life
- Type B according to DVS 2208-1 (mechanical calibrated pipe ends)
- Always delivered in pairs (also usable for SG 110, SG 125, not for SG 160)

d [mm]	Code	kg	kg/m
16	799 300 155	0.085	0.085
25	799 300 157	0.154	0.154
32	799 300 158	0.211	0.211
40	799 300 159	0.230	0.230
50	799 300 160	0.434	0.434
63	799 300 161	0.594	0.594
75	799 300 162	0.981	0.981
90	799 300 163	1.440	1.440
110	799 300 164	2.210	2.210

5310

Tempil sticks



Temperature [°C]	Code	kg	kg/m
253	761 066 796	0.012	0.012
274	761 066 797	0.014	0.014



Manual Pipe Peeling Tool for Socket Fusion

d [mm]	Code	kg	kg/m
20	799 300 260	0.087	0.087
25	799 300 270	0.080	0.080
32	799 300 280	0.099	0.099
40	799 300 290	0.240	0.240
50	799 300 300	0.244	0.244
63	799 300 310	0.507	0.507
75	799 300 320	0.680	0.680
90	799 300 330	1.006	1.006
110	799 300 340	1.355	1.355

KS Tangit Cleaner

- Special cleaning agent for plastic fusion connections with PP, PE, PVDF and PB.



Code	kg	kg/m
799 298 023	0.872	0.872

Tangit KS-Cleaning Tissues

- for plastic welding joints PB, PE, PP, PVDF
- Sales unit: 1 dispenser with 100 tissues.



Code	kg	kg/m
799 298 024	0.333	0.333



Marker

Type	Code	kg	kg/m
silver	799 350 364	0.010	0.010

90 10 90

PPC Plastic pipe cutter

- For cutting plastic pipes d10 - d160



d-d [mm]	Article	Code	kg	kg/m
10 - 63	PPC 63, s max. = 7.2mm	790 109 001	0.865	0.865
50 - 110	PPC 110, s max. = 12.7mm	790 109 002	1.624	1.624
110 - 160	PPC 160, s max. = 19.0mm	790 109 003	2.212	2.212

90 10 90

Replacement cutting wheels

- for plastic pipe cutter



d-d [mm]	Article	Code	kg	kg/m
10 - 63	SR 63 max. s=7,2 mm	790 109 011	0.004	0.004
50 - 110	SR 110/160 max. s=12,7 mm	790 109 012	0.015	0.015
110 - 160	SR 160 max. s=19,0 mm	790 109 013	0.023	0.023

General Condition of Supply of Georg Fischer Piping Systems (Switzerland) Limited, Schaffhausen

1 General

- 1.1 These General Conditions shall apply to all Products supplied by Georg Fischer to the Purchaser.

They shall also apply to all future business even when no express reference is made to them.

- 1.2 Any deviating or supplementary conditions especially Purchaser's general conditions of purchase and verbal agreements shall only be applicable if accepted in writing by Georg Fischer.
- 1.3 The written form shall be deemed to be fulfilled by all forms of transmission, evidenced in the form of text, such as telefax, e-mail, etc.

2 Tenders

Tenders shall only be binding if they contain a specifically stated period for acceptance.

3 Scope of Delivery

- 3.1 Georg Fischer's product range is subject to change.
- 3.2 The confirmation of order shall govern the scope and execution of the contract.

4 Data and Documents

- 4.1 Technical documents such as drawings, descriptions, illustrations and data on dimensions, performance and weight as well as the reference to standards are for information purposes only. They are not warranted characteristics and are subject to change.
- 4.2 All technical documents shall remain the exclusive property of Georg Fischer and may only be used for the agreed purposes or as Georg Fischer may consent.

5 Confidentiality, Protection of Personal Data

- 5.1 Each party shall keep in strict confidence all commercial or technical information relating to the business of the other party, of which it has gained knowledge in the course of its dealing with the other party. Such information shall neither be disclosed to third parties nor used for other purposes than those for which the information has been supplied.
- 5.2 In the context of the contractual relation with the Purchaser personal data may be processed. The Purchaser agrees to the disclosure of said data to third parties such as foreign subcontractors and suppliers etc .

6 Local Laws and Regulations, Export Controls

- 6.1 The Purchaser shall bring to the attention of Georg Fischer all local laws and regulations at the place of destination which bear connection with the execution of the contract and the adherence to relevant safety regulations and approval procedures.
- 6.2 In case of re-exports, Purchaser shall be responsible for compliance with pertinent export control regulations.

7 Price

- 7.1 Unless agreed otherwise, the prices shall be deemed quoted net ex works (according to Incoterms of the ICC, latest version) including standard packing. All supplementary costs such as the cost of carriage, insurance, export-, transit- and import- licences etc. shall be borne by the Purchaser. The Purchaser shall also bear the costs of all taxes, fees, duties etc. connected with the contract.
- 7.2 If the costs of packing, carriage, insurance, fees and other supplementary costs are included in the tender price or contract price or are referred to specifically in the tender or confirmation of order, Georg Fischer reserve the right to revise their prices accordingly should any change occur in the relevant tariffs.

8 Terms of Payment

- 8.1 The Purchaser shall make payment in the manner agreed by the parties without any deductions such as discounts, costs, taxes or dues.
- 8.2 The Purchaser may only withhold or off-set payments due against counter claims which are either expressly acknowledged by Georg Fischer or finally awarded to the Purchaser.

In particular, payment shall still be made when unessential items are still outstanding provided that the Products already delivered are not rendered unusable as a result.

9 Retention of Title

- 9.1 The Products shall remain the property of Georg Fischer until the Purchaser shall have settled all claims, present and future, which Georg Fischer may have against him.
- 9.2 Should the Purchaser resell Products to which title is reserved, in the ordinary course of business, he shall hereby be deemed to have tacitly assigned to Georg Fischer the proceeds deriving from their sale together with all collateral rights, securities and reservations of title until all claims held by Georg Fischer shall have been settled. Until revoked by Georg Fischer, this assignment shall not preclude Purchaser's right to collect the assigned receivables.
- 9.3 To the extent the value of the Products to which title is reserved together with collateral securities exceeds Georg Fischer's claims against the Purchaser by more than 20%, Georg Fischer shall re-assign the above proceeds to Purchaser at his request.

10 Delivery

- 10.1 The term of delivery shall commence as soon as the contract has been entered into, all official formalities such as import and payment permits have been obtained and all essential technical issues have been settled. The term of delivery shall be deemed duly observed when, upon its expiry, the Products are ready for despatch.
- 10.2 Delivery is subject to the following conditions, i.e. the term of delivery shall be reasonably extended:
- a) if Georg Fischer are not supplied in time with the information necessary for the execution of the contract or if subsequent changes causing delays are made by the Purchaser.
 - b) if Georg Fischer are prevented from performing the contract by force majeure. Force majeure shall equally be deemed to be any unforeseeable event beyond Georg Fischer's control which renders Georg Fischer's performance commercially unpractical or impossible, such as delayed or defective supplies from sub contractors labour disputes, governmental orders or regulations, shortages in materials or energy, seri-

ous disturbances in Georg Fischer's works, such as the total or partial destruction of plant and equipment or the breakdown of essential facilities, serious disruptions in transport facilities, e.g. impassable roads.

Should the effect of force majeure exceed a period of six months, either party may cancel the contract forthwith.

Georg Fischer shall not be liable for any damage or loss of any kind whatsoever resulting therefrom, any suspension or cancellation being without prejudice to Georg Fischer's right to recover all sums due in respect of consignments delivered and costs incurred to date.

- c) if the Purchaser is in delay with the fulfilment of his obligations under the contract, in particular, if he does not adhere to the agreed conditions of payment or if he has failed to timely provide the agreed securities.

- 10.3 If for reasons attributable to Georg Fischer the agreed term of delivery or a reasonable extension thereof is exceeded, Georg Fischer shall not be deemed in default until the Purchaser has granted to Georg Fischer in writing a reasonable extension thereof of not less than one month which equally is not met.

The Purchaser shall then be entitled to the remedies provided at law, it being however understood that, subject to limitations of Art. 16, damage claims shall be limited to max. 10% of the price of the delayed delivery.

- 10.4 Part shipments shall be allowed and Georg Fischer shall be entitled to invoice for such partial deliveries.
- 10.5 If the Purchaser fails to take delivery within a reasonable time of Products notified as ready for despatch, Georg Fischer shall be entitled to store the Products at the Purchaser's expense and risk and to invoice them as delivered. If Purchaser fails to effect payment, Georg Fischer shall be entitled to dispose of the Products.
- 10.6 Should Purchaser cancel an order without justification and should Georg Fischer not insist on the performance of the contract, Georg Fischer shall be entitled to a penalty amounting to 10% of the contract price, Georg Fischer's right to prove and claim higher damages remaining reserved. Purchaser shall be entitled to prove, that Georg Fischer has suffered no or a considerably lower damage than the penalty forfeited.

11 Packing

If the Products are provided with additional packing over and above the standard packing, such packing shall be charged additionally.

12 Passing of Risk

- 12.1 The risk in the Products shall pass to the Purchaser as soon as they have left Georg Fischer's works (EX WORKS, Incoterms ICC, latest version), even if delivery is made carriage-paid, under similar clauses or including installation or when carriage is organized and managed by Georg Fischer.
- 12.2 If delivery is delayed for reasons beyond Georg Fischer's control, the risk shall pass to the Purchaser when he is notified that the Products are ready for despatch.

13 Carriage and Insurance

- 13.1 Unless agreed otherwise, the Purchaser shall bear the cost of carriage.

- 13.2 The Purchaser shall be responsible for transport insurance against damage of whatever kind.

Even when such insurance is arranged by Georg Fischer it shall be deemed taken out by the order of and for the account of the Purchaser and at his risk.

- 13.3 Special requests regarding carriage and insurance shall be communicated to Georg Fischer in due time. Otherwise carriage shall be arranged by Georg Fischer at their discretion, but without responsibility, by the quickest and cheapest method possible.

In case of carriage-paid delivery transport arrangements shall be made by Georg Fischer. If the Purchaser specifies particular requirements, any extra costs involved shall be borne by him.

- 13.4 In the event of damage or loss of the Products during carriage the Purchaser shall mark the delivery documents accordingly and immediately have the damage ascertained by the carrier.

Not readily ascertainable damages sustained during carriage shall be notified to the carrier within six days after receipt of the Products.

14 Inspection, Notification of Defects and Damages

- 14.1 The Products will be subject to normal inspection by Georg Fischer during manufacture.

Additional tests required by the Purchaser shall be agreed upon in writing and shall be charged to the Purchaser.

- 14.2 It shall be a condition of Georg Fischer's obligation under the warranties stated hereinafter that Georg Fischer be notified in writing by the Purchaser of any purported defect immediately upon discovery. Notice concerning weight, numbers or apparent defects is to be given latest within 30 days from receipt of the Products, notice of other defects immediately latest within 7 working days after discovery, in any event within the agreed warranty period.

- 14.3 Purchaser shall not dispose of allegedly defective Products until all warranty and/or damage claims are finally settled. At its request, defective Products are to be placed at Georg Fischer's disposal.

- 14.4 At its request, Georg Fischer shall be given the opportunity to inspect the defect and/or damage, prior to commencement of remedial work, either itself or by third party experts.

15 Warranty

- 15.1 At the written request of the Purchaser, Georg Fischer undertakes to repair or replace at its discretion, as quickly as possible and free of charge, all Products supplied which demonstrably suffer from faulty design, materials or workmanship, from faulty operating or installation instructions or which become defective or unusable due to faulty advice.

In order to protect employees from toxic or radioactive substances which may have been transported through defective parts returned to Georg Fischer's sales organisation, said parts must be accompanied by a Material Safety Disclosure Form. The form may be obtained from Georg Fischer's local sales company or via www.piping.georgfischer.com.

Replaced parts shall become property of Georg Fischer, unless Georg Fischer waives such claim.

- 15.2 For Products which are manufactured to specifications, drawings or patterns supplied by the Purchaser, Georg Fischer's warranty shall be restricted to proper materials and workmanship.

- 15.3 The Purchaser shall be entitled to cancel the contract or to demand a reduction in the contract price if also a second attempt to repair or replace the Products has failed.
- 15.4 For Products or essential components manufactured by a third party and supplied by Georg Fischer under this contract, Georg Fischer's warranty is limited to the warranty provided by said third party.
- 15.5 This warranty shall not apply to damage resulting from normal wear and tear, improper storage and maintenance, failure to observe the operating instructions, overstressing or overloading, unsuitable operating media, unsuitable construction work or unsuitable building ground, improper repairs or alterations by the Purchaser or third parties, the use of other than original spare parts and other reasons beyond Georg Fischer's control.
- 15.6 No action or claim may be brought by the Purchaser on account of any alleged breach of warranty or any other obligation of Georg Fischer after the expiration of twelve (12) months from receipt of the Products by the end user or at the latest within eighteen (18) months of the Products being despatched by Georg Fischer.
- 15.7 In case of Products for use in domestic installations or in utilities
- Georg Fischer will assume the costs of dismantling the defective Product and restoring the damaged object up to CHF 1'000'000 per occurrence.
 - the statute of limitations for warranty or damage claims - contrary to Section 15.6 - will be 5 years from the date of installation.

16 Limitation of Liability

The rights and remedies of the customer are exclusively governed by these General Conditions of Supply. All further claims for damages, reduction of the purchase price, termination of or rescission of the contract are excluded. In no case whatsoever shall the customer be entitled to claim damages other than compensation for costs of remedying defects in the supplies. This in particular refers, but shall not be limited, to loss of production, loss of use, loss of orders, loss of profit, third party recovery claims and other direct or indirect or consequential damages.

This limitation of liability, however, does not apply in case unlawful intent or gross negligence on the part of Georg Fischer's management and in case of strict liability, in particular under applicable product liability statutes.

17 Severability

Should any term or clause of these General Conditions in whole or in part be found to be unenforceable or void, all other provisions shall remain in full force and effect and the unenforceable or void provision shall be replaced by a valid provision, which comes closest to the original intention of the unenforceable or invalid provision.

18 Place of Performance and Jurisdiction

18.1 Place of performance for the Products shall be the Georg Fischer works from which the Products are despatched.

18.2 Any civil action based upon any alleged breach of this contract shall be filed and prosecuted exclusively in the courts of Schaffhausen, Switzerland.

Georg Fischer however reserves the right to file actions in any court having jurisdiction over controversies arising out of or in connection with the present contract.

18.3 The contract shall be governed by Swiss law without regard to conflict of law provisions that would require the application of another law.

Index

Code	Page
-	253
160 480 115	499
160 480 116	499
160 480 117	499
160 480 118	499
160 480 119	499
160 480 120	499
160 480 130	512
161 300 308	553
161 300 358	553
161 300 408	553
161 300 458	553
161 300 508	553
161 300 558	553
161 305 303	552
161 305 336	554
161 305 337	553
161 305 338	553
161 305 339	553
161 305 353	552
161 305 386	554
161 305 387	553
161 305 388	553
161 305 389	553
161 305 403	552
161 305 436	554
161 305 437	553
161 305 438	553
161 305 439	553
161 305 453	552
161 305 486	554
161 305 487	553
161 305 488	553
161 305 489	553
161 305 503	552
161 305 536	554
161 305 537	553
161 305 538	553
161 305 539	553
161 305 553	552
161 305 586	554
161 305 587	553
161 305 588	553
161 305 589	553
161 305 603	552
161 305 604	554
161 305 636	554
161 305 637	553
161 305 638	553
161 305 639	553
161 305 653	552
161 305 654	554
161 305 686	554
161 305 687	553
161 305 688	553
161 305 689	553
161 311 698	535
161 311 699	535
161 311 700	535
161 311 701	535
161 311 702	535
161 311 703	535
161 311 710	535
161 311 711	535
161 311 712	535
161 311 713	535
161 311 714	535
161 311 715	535

Code	Page
161 311 728	535
161 311 729	535
161 311 730	535
161 311 731	535
161 311 732	535
161 311 733	535
161 330 304	558
161 330 354	558
161 330 404	558
161 330 454	558
161 330 504	558
161 330 554	558
161 330 654	558
161 340 617	500
161 340 618	500
161 340 619	500
161 340 620	500
161 340 621	500
161 340 623	559
161 367 051	520
161 367 052	520
161 367 071	521
161 367 072	521
161 367 171	520
161 367 172	520
161 367 191	521
161 367 192	521
161 367 351	521
161 367 352	521
161 367 371	521
161 367 625	520
161 367 626	520
161 367 627	520
161 367 628	520
161 367 629	520
161 367 630	520
161 367 635	521
161 367 636	521
161 367 637	521
161 367 638	521
161 367 639	521
161 367 640	521
161 367 685	521
161 367 686	521
161 367 687	521
161 367 688	521
161 367 689	521
161 367 690	521
161 367 695	521
161 367 696	521
161 367 697	521
161 367 698	521
161 367 699	521
161 367 700	521
161 369 122	566
161 369 123	566
161 369 124	566
161 369 125	566
161 369 126	566
161 369 127	566
161 369 128	566
161 369 129	566
161 369 130	566
161 369 131	566
161 369 132	566
161 369 142	566
161 369 143	566
161 369 144	566

Code	Page
161 369 145	566
161 369 146	566
161 369 147	566
161 369 148	566
161 369 149	566
161 369 150	566
161 369 151	566
161 369 152	566
161 480 132	560
161 480 133	560
161 480 141	559
161 480 149	559
161 480 158	561
161 480 231	540
161 480 232	540
161 480 233	540
161 480 237	540
161 480 238	540
161 480 239	540
161 480 240	540
161 480 241	540
161 480 242	540
161 480 282	532
161 480 283	532
161 480 284	532
161 480 285	532
161 480 286	532
161 480 287	532
161 480 420	510
161 480 522	500
161 480 536	500
161 480 537	500
161 480 538	500
161 480 539	500
161 480 540	500
161 480 541	500
161 480 542	500
161 480 543	500
161 480 544	500
161 480 545	500
161 480 546	500
161 480 547	500
161 480 548	500
161 480 549	500
161 480 550	501
161 480 551	501
161 480 552	501
161 480 553	501
161 480 554	501
161 480 555	501
161 480 556	501
161 480 715	507
161 480 716	507
161 480 717	507
161 480 718	507
161 480 724	512
161 480 725	499
161 480 726	499
161 480 727	499
161 480 728	499
161 480 729	499
161 480 730	499
161 480 763	510
161 480 764	510
161 480 784	524
161 481 022	535
161 481 023	535
161 481 024	535

Index

Code	Page
161 481 025	535
161 481 026	535
161 481 027	535
161 481 028	540
161 481 029	540
161 481 030	540
161 481 092	535
161 481 093	535
161 481 094	535
161 481 095	535
161 481 096	535
161 481 097	535
161 481 098	540
161 481 099	540
161 481 100	540
161 481 102	540
161 481 145	514
161 481 146	514
161 481 147	514
161 481 148	514
161 481 218	536
161 481 219	536
161 481 220	536
161 481 221	536
161 481 222	536
161 481 223	536
161 481 260	510
161 481 261	510
161 481 262	510
161 481 274	539
161 481 275	539
161 481 276	539
161 481 277	539
161 481 278	539
161 481 279	539
161 481 286	539
161 481 287	539
161 481 288	539
161 481 289	539
161 481 290	539
161 481 291	539
161 481 400	524
161 481 401	524
161 481 402	524
161 481 696	541
161 481 759	542
161 481 760	542
161 481 764	541
161 481 765	541
161 481 926	535
161 481 927	535
161 481 928	535
161 481 929	535
161 481 930	535
161 481 931	535
161 481 932	540
161 482 017	554
161 482 018	554
161 482 019	554
161 482 020	554
161 482 021	554
161 482 022	554
161 482 076	554
161 482 119	504
161 482 146	507
161 482 147	507
161 482 151	504
161 482 152	504

Code	Page
161 482 153	504
161 482 154	504
161 482 155	504
161 482 156	504
161 482 339	512
161 482 345	501
161 482 346	501
161 482 347	501
161 482 348	501
161 482 349	501
161 482 350	501
161 482 351	501
161 482 377	500
161 482 378	500
161 482 379	500
161 482 380	500
161 482 381	500
161 482 382	500
161 482 383	500
161 482 389	501
161 482 390	501
161 482 391	501
161 482 392	501
161 482 393	501
161 482 394	501
161 482 395	501
161 482 400	541
161 482 401	541
161 482 408	523
161 482 514	540
161 482 515	540
161 482 516	540
161 482 517	540
161 482 613	508
161 482 656	522
161 482 657	522
161 482 664	522
161 482 665	522
161 482 668	522
161 482 669	522
161 482 696	541
161 482 744	542
161 482 751	540
161 482 754	540
161 482 757	540
161 482 760	540
161 482 869	499
161 482 870	499
161 482 871	499
161 482 872	499
161 482 873	499
161 482 874	499
161 482 875	499
161 482 876	499
161 482 877	499
161 482 878	499
161 482 879	499
161 482 880	499
161 482 883	500
161 482 884	500
161 482 885	500
161 482 886	500
161 482 887	500
161 482 888	500
161 482 892	500
161 482 893	500
161 482 894	500
161 482 895	500

Code	Page
161 482 896	500
161 482 897	500
161 482 901	540
161 482 906	540
161 482 910	561
161 482 911	561
161 482 912	561
161 482 913	561
161 482 914	561
161 482 915	561
161 482 920	561
161 482 921	561
161 482 922	561
161 482 923	561
161 482 924	561
161 482 925	561
161 482 958	510
161 482 959	510
161 482 960	510
161 482 963	510
161 482 964	510
161 482 965	510
161 482 968	511
161 482 969	511
161 482 970	511
161 482 974	511
161 482 975	511
161 482 976	511
161 482 986	512
161 482 987	512
161 482 989	512
161 482 990	512
161 483 008	541
161 483 009	541
161 483 011	541
161 483 020	541
161 483 021	541
161 483 023	541
161 483 032	541
161 483 033	541
161 483 034	541
161 483 037	541
161 483 040	522
161 483 041	522
161 483 042	522
161 483 043	522
161 483 044	522
161 483 045	522
161 483 052	522
161 483 053	522
161 483 054	522
161 483 055	522
161 483 056	522
161 483 057	522
161 483 110	541
161 483 111	541
161 483 112	541
161 483 113	541
161 483 114	541
161 483 115	541
161 483 116	541
161 483 126	551
161 483 127	551
161 483 128	551
161 483 129	551
161 483 130	551
161 483 131	551
161 483 132	551

Index

Code	Page
161 483 133	551
161 483 135	523
161 483 136	523
161 483 137	523
161 483 138	523
161 483 139	523
161 483 140	523
161 483 259	559
161 483 260	559
161 483 261	559
161 483 262	559
161 483 263	559
161 483 264	559
161 483 265	559
161 483 266	559
161 483 267	559
161 483 268	559
161 483 269	559
161 483 270	559
161 483 343	507
161 483 344	507
161 483 345	507
161 483 346	507
161 483 347	507
161 483 348	507
161 483 351	507
161 483 352	507
161 483 353	507
161 483 354	507
161 483 355	507
161 483 356	507
161 483 422	524
161 483 423	524
161 483 424	524
161 483 462	524
161 483 464	524
161 483 837	515
161 483 838	515
161 483 839	515
161 483 840	515
161 483 841	515
161 483 842	515
161 483 851	558
161 483 852	558
161 483 853	558
161 483 854	558
161 483 855	558
161 483 856	558
161 483 857	558
161 483 861	558
161 483 862	558
161 483 863	558
161 483 864	558
161 483 865	558
161 483 866	558
161 483 867	558
161 483 930	498
161 483 931	498
161 483 932	498
161 483 933	498
161 483 934	498
161 483 935	498
161 483 936	498
161 483 940	498
161 483 941	498
161 483 942	498
161 483 943	498
161 483 944	498

Code	Page
161 483 945	498
161 483 946	498
161 483 978	541
161 483 979	541
161 483 980	541
161 483 981	541
161 483 982	541
161 483 983	541
161 483 984	541
161 483 987	523
161 484 230	507
161 484 231	507
161 484 232	507
161 484 233	507
161 484 234	507
161 484 235	507
161 484 236	507
161 484 240	507
161 484 241	507
161 484 242	507
161 484 243	507
161 484 244	507
161 484 245	507
161 484 246	507
161 484 452	535
161 484 453	535
161 484 454	535
161 484 455	535
161 484 456	535
161 484 457	535
161 484 458	540
161 484 459	540
161 484 460	540
161 484 561	509
161 484 562	509
161 484 563	509
161 484 564	509
161 484 565	509
161 484 566	509
161 484 601	500
161 484 602	500
161 484 603	500
161 484 604	500
161 484 605	500
161 484 606	500
161 484 610	501
161 484 611	501
161 484 612	501
161 484 613	501
161 484 614	501
161 484 615	501
161 484 625	535
161 484 626	535
161 484 627	535
161 484 628	535
161 484 629	535
161 484 630	535
161 484 631	540
161 484 632	535
161 484 633	535
161 484 634	535
161 484 635	535
161 484 636	535
161 484 637	535
161 484 638	540
161 484 688	535
161 484 689	535
161 484 690	535

Code	Page
161 484 691	535
161 484 692	535
161 484 693	535
161 484 694	541
161 484 696	535
161 484 697	535
161 484 698	535
161 484 699	535
161 484 700	535
161 484 701	535
161 484 702	541
161 484 704	536
161 484 705	536
161 484 706	536
161 484 707	536
161 484 708	536
161 484 709	536
161 484 743	541
161 484 744	541
161 484 745	541
161 484 746	541
161 484 747	541
161 484 748	541
161 484 749	541
161 484 768	524
161 484 769	524
161 484 770	524
161 484 771	524
161 484 772	524
161 484 773	524
161 484 774	524
161 484 836	523
161 484 875	566
161 484 876	566
161 484 877	566
161 484 878	566
161 484 879	566
161 484 880	566
161 484 881	566
161 484 882	566
161 484 883	566
161 484 884	566
161 484 885	566
161 484 887	566
161 484 888	566
161 484 889	566
161 484 890	566
161 484 891	566
161 484 892	566
161 484 893	566
161 484 894	566
161 484 895	566
161 484 896	566
161 484 897	566
161 484 900	566
161 484 901	566
161 484 902	566
161 484 903	566
161 484 904	566
161 484 905	566
161 484 907	567
161 484 908	567
161 484 909	567
161 484 910	567
161 484 912	566
161 484 913	566
161 484 914	566
161 484 915	566

Index

Code	Page	Code	Page	Code	Page
161 484 916	566	161 485 221	555	161 485 296	562
161 484 917	566	161 485 222	555	161 485 297	562
161 484 919	567	161 485 223	555	161 485 298	562
161 484 920	567	161 485 224	555	161 485 299	562
161 484 921	567	161 485 225	555	161 485 351	492
161 484 922	567	161 485 226	555	161 485 353	492
161 484 941	504	161 485 227	556	161 485 361	492
161 484 942	504	161 485 228	556	161 485 363	492
161 484 943	504	161 485 229	556	161 486 006	131
161 484 944	504	161 485 231	555	161 486 007	131
161 484 945	504	161 485 232	555	161 486 008	131
161 484 946	504	161 485 233	555	161 486 009	131
161 484 951	504	161 485 234	555	161 486 010	131
161 484 952	504	161 485 235	555	161 486 015	503
161 484 953	504	161 485 236	555	161 486 016	503
161 484 954	504	161 485 237	556	161 486 017	503
161 484 955	504	161 485 238	556	161 486 018	503
161 484 956	504	161 485 239	556	161 486 019	503
161 485 112	564	161 485 241	557	161 486 020	503
161 485 113	564	161 485 242	557	161 486 027	503
161 485 114	564	161 485 243	557	161 486 028	503
161 485 115	564	161 485 244	557	161 486 029	503
161 485 116	564	161 485 245	557	161 486 030	503
161 485 117	564	161 485 246	557	161 486 031	503
161 485 118	564	161 485 247	557	161 486 032	503
161 485 119	564	161 485 248	557	161 486 039	503
161 485 132	557	161 485 249	557	161 486 040	503
161 485 133	557	161 485 251	557	161 486 041	503
161 485 134	557	161 485 252	557	161 486 042	503
161 485 135	557	161 485 253	557	161 486 043	503
161 485 136	557	161 485 254	557	161 486 044	503
161 485 137	557	161 485 255	557	161 486 051	503
161 485 138	557	161 485 256	557	161 486 052	503
161 485 139	557	161 485 257	557	161 486 053	503
161 485 142	557	161 485 258	557	161 486 054	503
161 485 143	557	161 485 259	557	161 486 055	503
161 485 144	557	161 485 261	562	161 486 056	503
161 485 145	557	161 485 262	562	161 486 100	554
161 485 146	557	161 485 263	562	161 486 101	554
161 485 147	557	161 485 264	562	161 486 102	554
161 485 148	557	161 485 265	562	161 486 103	554
161 485 149	557	161 485 266	562	161 486 104	554
161 485 152	557	161 485 267	562	161 486 105	554
161 485 153	557	161 485 268	562	161 486 106	554
161 485 154	557	161 485 269	562	161 486 107	554
161 485 155	557	161 485 271	562	161 486 151	490
161 485 156	557	161 485 272	562	161 486 152	490
161 485 157	557	161 485 273	562	161 486 153	490
161 485 158	557	161 485 274	562	161 486 154	490
161 485 159	557	161 485 275	562	161 486 155	490
161 485 201	555	161 485 276	562	161 486 156	490
161 485 202	555	161 485 277	562	161 486 157	490
161 485 203	555	161 485 278	562	161 486 158	490
161 485 204	555	161 485 279	562	161 486 159	490
161 485 205	555	161 485 281	562	161 486 163	490
161 485 206	555	161 485 282	562	161 486 164	490
161 485 207	555	161 485 283	562	161 486 165	490
161 485 208	555	161 485 284	562	161 486 166	490
161 485 209	555	161 485 285	562	161 486 167	490
161 485 211	555	161 485 286	562	161 486 168	490
161 485 212	555	161 485 287	562	161 486 169	490
161 485 213	555	161 485 288	562	161 486 170	490
161 485 214	555	161 485 289	562	161 486 171	490
161 485 215	555	161 485 291	562	161 486 175	504
161 485 216	555	161 485 292	562	161 486 176	504
161 485 217	555	161 485 293	562	161 486 177	504
161 485 218	555	161 485 294	562	161 486 178	504
161 485 219	555	161 485 295	562	161 486 179	504

Index

Code	Page
161 486 180	504
161 486 192	523
161 486 193	523
161 486 194	523
161 486 195	523
161 486 196	523
161 486 197	523
161 486 265	549
161 486 266	549
161 486 267	549
161 486 268	549
161 486 269	549
161 486 270	549
161 486 271	550
161 486 272	550
161 486 273	550
161 486 275	549
161 486 276	549
161 486 277	549
161 486 278	549
161 486 279	549
161 486 280	549
161 486 281	550
161 486 282	550
161 486 283	550
161 486 285	549
161 486 286	549
161 486 287	549
161 486 288	549
161 486 289	549
161 486 290	549
161 486 291	550
161 486 292	550
161 486 293	550
161 486 301	131
161 486 302	131
161 486 303	131
161 486 304	131
161 486 305	131
161 486 325	519
161 486 326	519
161 486 327	519
161 486 328	520
161 486 360	549
161 486 361	549
161 486 362	549
161 486 363	549
161 486 364	549
161 486 365	549
161 486 375	491
161 486 376	491
161 486 377	491
161 486 378	491
161 486 379	491
161 486 380	491
161 486 381	491
161 486 382	491
161 486 383	491
161 486 385	491
161 486 386	491
161 486 387	491
161 486 388	491
161 486 389	491
161 486 390	491
161 486 391	491
161 486 392	491
161 486 393	491
161 486 400	492

Code	Page
161 486 401	492
161 486 402	492
161 486 403	492
161 486 404	492
161 486 405	492
161 486 406	492
161 486 407	492
161 486 408	492
161 486 410	492
161 486 411	492
161 486 412	492
161 486 413	492
161 486 414	492
161 486 415	492
161 486 416	492
161 486 417	492
161 486 418	492
161 486 425	550
161 486 426	550
161 486 427	550
161 486 428	550
161 486 429	550
161 486 430	550
161 486 431	550
161 486 432	550
161 486 433	550
161 486 435	97
161 486 436	97
161 486 437	97
161 486 438	97
161 486 443	98
161 486 444	98
161 486 445	98
161 486 446	98
161 486 689	491
161 486 690	491
161 486 691	491
161 486 694	519
161 486 695	520
161 486 697	520
161 486 855	131
161 486 856	131
161 486 857	131
161 486 858	131
161 486 859	131
161 486 861	517
161 486 862	517
161 486 863	517
161 486 864	517
161 486 865	517
161 486 866	517
161 486 867	517
161 486 868	517
161 486 869	517
161 486 873	517
161 486 874	517
161 486 875	517
161 486 876	517
161 486 877	517
161 486 878	517
161 486 879	517
161 486 880	517
161 486 881	517
161 486 886	518
161 486 887	518
161 486 888	518
161 486 889	518
161 486 892	518

Code	Page
161 486 893	518
161 486 894	518
161 486 895	518
161 486 899	519
161 486 900	519
161 486 901	519
161 486 902	519
161 486 903	519
161 486 904	519
161 486 905	519
161 486 906	519
161 486 907	519
161 486 908	519
161 486 909	519
161 486 926	519
161 486 927	519
161 486 928	519
161 486 959	518
161 486 960	518
161 486 961	518
161 486 962	518
161 486 963	518
161 486 964	518
161 486 965	518
161 486 966	518
161 486 967	518
161 486 979	518
161 486 980	518
161 486 981	518
161 486 982	518
161 486 983	518
161 486 984	518
161 486 985	518
161 486 986	518
161 486 987	518
161 488 002	493
161 488 003	493
161 488 004	493
161 488 005	493
161 488 006	493
161 488 007	493
161 488 012	493
161 488 013	493
161 488 014	493
161 488 015	493
161 488 016	493
161 488 017	493
161 488 022	493
161 488 023	493
161 488 024	493
161 488 025	493
161 488 026	493
161 488 027	493
161 488 032	493
161 488 033	493
161 488 034	493
161 488 035	493
161 488 036	493
161 488 037	493
161 488 041	496
161 488 042	496
161 488 043	496
161 488 044	496
161 488 045	496
161 488 046	496
161 488 047	496
161 488 051	496
161 488 052	496

Index

Code	Page	Code	Page	Code	Page
161 488 053	496	161 488 243	495	161 490 705	547
161 488 054	496	161 488 244	495	161 490 706	547
161 488 055	496	161 488 245	495	161 490 707	547
161 488 056	496	161 488 246	495	161 490 708	547
161 488 057	496	161 488 247	495	161 490 709	547
161 488 061	496	161 488 248	495	161 490 710	547
161 488 062	496	161 488 249	495	161 490 712	547
161 488 063	496	161 488 250	495	161 490 713	547
161 488 064	496	161 488 251	495	161 490 714	547
161 488 065	496	161 488 252	495	161 490 715	547
161 488 066	496	161 488 253	495	161 490 716	547
161 488 067	496	161 490 439	502	161 490 717	547
161 488 071	496	161 490 440	502	161 490 718	547
161 488 072	496	161 490 441	502	161 490 719	547
161 488 073	496	161 490 442	502	161 490 720	547
161 488 074	496	161 490 443	502	161 490 721	547
161 488 075	496	161 490 444	502	161 490 723	547
161 488 076	496	161 490 450	502	161 490 724	547
161 488 077	496	161 490 451	502	161 490 725	547
161 488 162	494	161 490 452	502	161 490 726	547
161 488 163	494	161 490 453	502	161 490 727	547
161 488 164	494	161 490 454	502	161 490 728	547
161 488 165	494	161 490 455	502	161 490 729	547
161 488 166	494	161 490 461	503	161 490 730	548
161 488 167	494	161 490 462	503	161 490 731	548
161 488 172	494	161 490 463	503	161 490 732	548
161 488 173	494	161 490 464	503	161 490 734	547
161 488 174	494	161 490 465	503	161 490 735	547
161 488 175	494	161 490 466	503	161 490 736	547
161 488 176	494	161 490 472	503	161 490 737	547
161 488 177	494	161 490 473	503	161 490 738	547
161 488 182	494	161 490 474	503	161 490 739	547
161 488 183	494	161 490 475	503	161 490 740	547
161 488 184	494	161 490 476	503	161 490 742	547
161 488 185	494	161 490 477	503	161 490 743	547
161 488 186	494	161 490 538	550	161 490 825	547
161 488 187	494	161 490 539	550	161 490 826	547
161 488 192	494	161 490 540	550	161 490 827	547
161 488 193	494	161 490 541	550	161 490 828	547
161 488 194	494	161 490 542	550	161 490 829	547
161 488 195	494	161 490 543	550	161 490 830	547
161 488 196	494	161 490 544	550	161 490 831	547
161 488 197	494	161 490 545	550	161 490 889	518
161 488 202	497	161 490 546	550	161 490 890	518
161 488 203	497	161 490 666	547	161 490 891	518
161 488 204	497	161 490 667	547	161 490 892	518
161 488 205	497	161 490 668	547	161 490 893	518
161 488 206	497	161 490 669	547	161 490 894	518
161 488 207	497	161 490 670	547	161 490 895	518
161 488 212	497	161 490 671	547	161 490 896	518
161 488 213	497	161 490 672	547	161 490 897	518
161 488 214	497	161 490 673	547	161 490 920	98
161 488 215	497	161 490 674	547	161 490 921	98
161 488 216	497	161 490 675	547	161 491 151	556
161 488 217	497	161 490 690	547	161 491 152	556
161 488 222	497	161 490 691	547	161 491 153	556
161 488 223	497	161 490 692	547	161 491 154	556
161 488 224	497	161 490 693	547	161 491 155	556
161 488 225	497	161 490 694	547	161 491 156	556
161 488 226	497	161 490 695	547	161 491 157	556
161 488 227	497	161 490 696	547	161 491 158	556
161 488 232	497	161 490 697	548	161 491 159	556
161 488 233	497	161 490 698	548	161 492 062	531
161 488 234	497	161 490 699	548	161 492 063	531
161 488 235	497	161 490 701	547	161 492 064	531
161 488 236	497	161 490 702	547	161 492 065	531
161 488 237	497	161 490 703	547	161 492 066	531
161 488 242	495	161 490 704	547	161 492 067	531

Index

Code	Page
161 492 072	532
161 492 073	532
161 492 074	532
161 492 075	532
161 492 076	532
161 492 077	532
163 305 330	551
163 305 331	551
163 305 332	551
163 305 333	551
163 305 334	551
163 305 335	551
163 480 081	500
163 480 082	500
163 480 083	500
163 480 084	500
163 480 085	500
163 480 135	539
163 480 136	539
163 480 137	539
163 480 138	539
163 480 139	539
163 480 140	539
163 480 172	500
163 480 173	500
163 480 174	500
163 480 175	500
163 480 176	500
163 480 177	500
163 480 178	500
163 480 271	539
163 480 272	539
163 480 273	539
163 480 274	539
163 480 275	539
163 480 276	539
163 480 522	500
163 480 523	500
163 480 524	500
163 480 525	500
163 480 526	500
163 480 527	500
163 480 528	500
163 480 535	499
163 480 536	499
163 480 537	499
163 480 538	499
163 480 539	499
163 480 540	499
163 480 545	499
163 480 546	499
163 480 547	499
163 480 548	499
163 480 549	499
163 480 550	499
163 480 620	498
163 480 621	498
163 480 622	498
163 480 623	498
163 480 624	498
163 480 625	498
163 480 626	498
163 480 630	498
163 480 631	498
163 480 632	498
163 480 633	498
163 480 634	498
163 480 635	498

Code	Page
163 480 636	498
163 480 645	558
163 480 646	558
163 480 647	558
163 480 648	558
163 480 649	558
163 480 650	558
163 480 651	558
163 480 655	558
163 480 656	558
163 480 657	558
163 480 658	558
163 480 659	558
163 480 660	558
163 480 661	558
163 480 677	541
163 480 678	541
163 480 798	510
163 480 799	510
163 480 800	510
163 480 803	510
163 480 804	510
163 480 805	510
163 480 808	541
163 480 809	541
163 480 810	541
163 480 811	541
163 480 812	541
163 480 813	541
163 480 814	541
163 480 825	501
163 480 826	501
163 480 827	501
163 480 828	501
163 480 829	501
163 480 830	501
163 480 831	501
163 480 832	501
163 480 833	501
163 480 834	501
163 480 835	501
163 480 836	501
163 480 837	501
163 480 838	501
163 480 913	502
163 480 914	502
163 480 915	502
163 480 916	502
163 480 917	502
163 480 918	502
163 480 924	502
163 480 925	502
163 480 926	502
163 480 927	502
163 480 928	502
163 480 929	502
163 480 935	503
163 480 936	503
163 480 937	503
163 480 938	503
163 480 939	503
163 480 940	503
163 480 946	503
163 480 947	503
163 480 948	503
163 480 949	503
163 480 950	503
163 480 951	503

Code	Page
163 480 995	500
163 481 000	503
163 481 001	503
163 481 002	503
163 481 003	503
163 481 004	503
163 481 005	503
163 481 012	503
163 481 013	503
163 481 014	503
163 481 015	503
163 481 016	503
163 481 017	503
163 481 024	503
163 481 025	503
163 481 026	503
163 481 027	503
163 481 028	503
163 481 029	503
163 481 036	503
163 481 037	503
163 481 038	503
163 481 039	503
163 481 040	503
163 481 041	503
163 481 075	552
163 481 076	552
163 481 077	552
163 481 078	552
163 481 079	552
163 481 080	552
163 481 084	553
163 481 085	553
163 481 086	553
163 481 087	553
163 481 088	553
163 481 089	553
163 481 102	552
163 481 103	552
163 481 104	552
163 481 105	552
163 481 106	552
163 481 107	552
163 481 211	509
163 481 212	509
163 481 213	509
163 481 226	550
163 481 227	550
163 481 228	550
163 481 229	550
163 481 230	550
163 481 231	550
163 481 232	550
163 481 233	550
163 481 234	550
163 481 235	509
163 481 236	509
163 481 237	509
163 481 251	490
163 481 252	490
163 481 253	490
163 481 254	490
163 481 255	490
163 481 256	490
163 481 257	490
163 481 258	490
163 481 259	490
163 481 263	490

Index

Code	Page
163 481 264	490
163 481 265	490
163 481 266	490
163 481 267	490
163 481 268	490
163 481 269	490
163 481 270	490
163 481 271	490
163 481 275	547
163 481 276	547
163 481 277	547
163 481 278	547
163 481 279	547
163 481 280	547
163 481 281	547
163 481 282	547
163 481 283	547
163 481 284	547
163 481 286	547
163 481 287	547
163 481 288	547
163 481 289	547
163 481 290	547
163 481 291	547
163 481 292	547
163 481 293	548
163 481 294	548
163 481 295	548
163 481 300	547
163 481 301	547
163 481 302	547
163 481 303	547
163 481 304	547
163 481 305	547
163 481 306	547
163 481 307	547
163 481 308	547
163 481 309	547
163 481 311	547
163 481 312	547
163 481 313	547
163 481 314	547
163 481 315	547
163 481 316	547
163 481 317	547
163 481 318	547
163 481 319	547
163 481 320	547
163 481 322	548
163 481 323	548
163 481 324	548
163 481 325	548
163 481 326	548
163 481 327	548
163 481 328	548
163 481 329	548
163 481 330	548
163 481 331	548
163 481 351	522
163 481 352	522
163 481 354	522
163 481 355	522
163 481 359	522
163 481 360	522
163 481 362	522
163 481 363	522
163 481 375	491
163 481 376	491

Code	Page
163 481 377	491
163 481 378	491
163 481 379	491
163 481 380	491
163 481 381	491
163 481 382	491
163 481 383	491
163 481 385	491
163 481 386	491
163 481 387	491
163 481 388	491
163 481 389	491
163 481 390	491
163 481 391	491
163 481 392	491
163 481 393	491
163 481 400	548
163 481 401	548
163 481 402	548
163 481 403	548
163 481 404	548
163 481 405	548
163 481 406	548
163 481 412	550
163 481 413	550
163 481 414	550
163 481 415	550
163 481 416	550
163 481 417	550
163 481 418	550
163 481 419	550
163 481 420	550
163 481 425	550
163 481 426	550
163 481 427	550
163 481 428	550
163 481 429	550
163 481 430	550
163 481 431	550
163 481 432	550
163 481 433	550
163 481 451	518
163 481 452	518
163 481 453	518
163 481 454	518
163 481 455	518
163 481 456	518
163 481 457	518
163 481 576	518
163 481 577	518
163 481 578	518
163 481 582	518
163 481 583	518
163 481 584	518
163 481 591	517
163 481 592	517
163 481 593	517
163 481 594	517
163 481 595	517
163 481 596	517
163 481 597	517
163 481 603	517
163 481 604	517
163 481 605	517
163 481 606	517
163 481 607	517
163 481 608	517
163 481 609	517

Code	Page
163 481 902	493
163 481 903	493
163 481 904	493
163 481 905	493
163 481 906	493
163 481 907	493
163 481 912	493
163 481 913	493
163 481 914	493
163 481 915	493
163 481 916	493
163 481 917	493
163 481 922	493
163 481 923	493
163 481 924	493
163 481 925	493
163 481 926	493
163 481 927	493
163 481 932	493
163 481 933	493
163 481 934	493
163 481 935	493
163 481 936	493
163 481 937	493
163 481 982	494
163 481 983	494
163 481 984	494
163 481 985	494
163 481 986	494
163 481 987	494
163 481 992	494
163 481 993	494
163 481 994	494
163 481 995	494
163 481 996	494
163 481 997	494
163 482 002	494
163 482 003	494
163 482 004	494
163 482 005	494
163 482 006	494
163 482 007	494
163 482 012	494
163 482 013	494
163 482 014	494
163 482 015	494
163 482 016	494
163 482 017	494
163 482 052	531
163 482 053	531
163 482 054	531
163 482 055	531
163 482 056	531
163 482 057	531
163 482 062	532
163 482 063	532
163 482 064	532
163 482 065	532
163 482 066	532
163 482 067	532
163 482 151	556
163 482 152	556
163 482 153	556
163 482 154	556
163 482 155	556
163 482 156	556
163 482 157	556
163 482 158	556

Index

Code	Page
163 482 159	556
163 485 201	555
163 485 202	555
163 485 203	555
163 485 204	555
163 485 205	555
163 485 206	555
163 485 207	555
163 485 208	555
163 485 209	555
163 485 211	555
163 485 212	555
163 485 213	555
163 485 214	555
163 485 215	555
163 485 216	555
163 485 217	555
163 485 218	555
163 485 219	555
163 485 221	555
163 485 222	555
163 485 223	555
163 485 224	555
163 485 225	555
163 485 226	555
163 485 227	556
163 485 228	556
163 485 229	556
163 485 231	555
163 485 232	555
163 485 233	555
163 485 234	555
163 485 235	555
163 485 236	555
163 485 237	556
163 485 238	556
163 485 239	556
163 485 261	562
163 485 262	562
163 485 263	562
163 485 264	562
163 485 265	562
163 485 266	562
163 485 267	562
163 485 268	562
163 485 269	562
163 485 271	562
163 485 272	562
163 485 273	562
163 485 274	562
163 485 275	562
163 485 276	562
163 485 277	562
163 485 278	562
163 485 279	562
163 485 281	562
163 485 282	562
163 485 283	562
163 485 284	562
163 485 285	562
163 485 286	562
163 485 287	562
163 485 288	562
163 485 289	562
163 485 291	562
163 485 292	562
163 485 293	562
163 485 294	562

Code	Page
163 485 295	562
163 485 296	562
163 485 297	562
163 485 298	562
163 485 299	562
167 050 226	63
167 050 227	63
167 050 228	63
167 050 229	63
167 050 230	63
167 050 231	63
167 060 019	489
167 060 020	489
167 060 021	489
167 060 022	489
167 060 023	489
167 060 024	489
167 060 025	489
167 060 038	489
167 060 039	489
167 060 040	489
167 060 041	489
167 060 042	489
167 060 043	489
167 061 003	487
167 061 004	487
167 061 012	487
167 061 013	487
167 061 014	487
167 061 015	487
167 061 016	487
167 061 017	487
167 061 035	487
167 061 036	487
167 061 037	487
167 061 038	487
167 061 039	487
167 061 040	487
167 061 041	487
167 061 153	487
167 061 155	487
167 061 156	487
167 061 157	487
167 061 158	487
167 061 159	488
167 061 160	488
167 061 161	488
167 061 162	488
167 061 163	488
167 061 164	488
167 061 165	488
167 061 166	488
167 061 167	488
167 305 000	153
167 305 001	551
167 305 002	551
167 305 003	551
167 305 004	551
167 305 005	551
167 305 006	551
167 305 010	552
167 305 011	552
167 305 012	552
167 305 013	552
167 305 014	552
167 305 015	552
167 305 020	552
167 305 021	552

Code	Page
167 305 022	552
167 305 023	552
167 305 024	552
167 305 025	552
167 305 030	554
167 305 031	554
167 305 032	554
167 305 033	554
167 305 034	554
167 305 035	554
167 305 040	552
167 305 041	552
167 305 042	552
167 305 043	552
167 305 044	552
167 305 045	552
167 305 049	153
167 305 050	153
167 305 060	553
167 305 061	553
167 305 062	553
167 305 063	553
167 305 064	553
167 305 065	553
167 305 070	553
167 305 071	553
167 305 072	553
167 305 073	553
167 305 074	553
167 305 075	553
167 305 099	153
167 305 100	153
167 305 149	153
167 305 150	153
167 305 199	153
167 305 200	153
167 305 249	153
167 305 250	153
167 305 299	153
167 305 300	153
167 305 349	153
167 305 350	153
167 305 399	153
167 305 400	153
167 305 449	153
167 305 450	153
167 305 499	153
167 305 500	153
167 305 549	153
167 305 550	153
167 305 599	153
167 317 009	125
167 317 012	125
167 317 024	125
167 317 027	125
167 317 039	125
167 317 042	125
167 317 310	125
167 317 325	125
167 317 340	125
167 317 523	125
167 317 538	125
167 367 051	521
167 367 052	521
167 367 071	521
167 367 072	521
167 367 171	521
167 367 191	521

Index

Code	Page
167 367 351	521
167 367 371	521
167 367 535	521
167 367 536	521
167 367 537	521
167 367 538	521
167 367 539	521
167 367 540	521
167 367 625	521
167 367 626	521
167 367 627	521
167 367 628	521
167 367 629	521
167 367 630	521
167 367 635	521
167 367 636	521
167 367 637	521
167 367 638	521
167 367 639	521
167 367 640	521
167 369 002	148
167 369 003	148
167 369 004	148
167 369 005	148
167 369 006	148
167 369 007	148
167 369 009	148
167 369 010	148
167 369 011	148
167 369 012	148
167 369 013	148
167 369 022	148
167 369 023	148
167 369 024	148
167 369 025	148
167 369 026	148
167 369 027	148
167 369 029	148
167 369 030	148
167 369 031	148
167 369 032	148
167 369 033	148
167 369 042	149
167 369 043	149
167 369 044	149
167 369 045	149
167 369 046	149
167 369 047	149
167 369 049	149
167 369 050	149
167 369 051	149
167 369 052	149
167 369 053	149
167 369 062	149
167 369 063	149
167 369 064	149
167 369 065	149
167 369 066	149
167 369 067	149
167 369 069	149
167 369 070	149
167 369 071	149
167 369 072	149
167 369 073	149
167 369 082	150
167 369 083	150
167 369 084	150
167 369 085	150

Code	Page
167 369 086	150
167 369 087	150
167 369 089	150
167 369 090	150
167 369 091	150
167 369 092	150
167 369 093	150
167 369 102	150
167 369 103	150
167 369 104	150
167 369 105	150
167 369 106	150
167 369 107	150
167 369 109	150
167 369 110	150
167 369 111	150
167 369 112	150
167 369 113	150
167 369 122	566
167 369 123	566
167 369 124	566
167 369 125	566
167 369 126	566
167 369 127	566
167 369 128	566
167 369 129	566
167 369 130	566
167 369 131	566
167 369 132	566
167 369 142	566
167 369 143	566
167 369 144	566
167 369 145	566
167 369 146	566
167 369 147	566
167 369 148	566
167 369 149	566
167 369 150	566
167 369 151	566
167 369 152	566
167 480 024	558
167 480 025	558
167 480 026	558
167 480 027	558
167 480 028	558
167 480 029	558
167 480 159	500
167 480 160	500
167 480 161	500
167 480 162	500
167 480 163	500
167 480 164	500
167 480 165	500
167 480 166	501
167 480 167	501
167 480 168	501
167 480 169	501
167 480 170	501
167 480 171	501
167 480 172	501
167 480 328	539
167 480 329	539
167 480 330	539
167 480 331	539
167 480 332	539
167 480 333	539
167 480 334	522
167 480 335	522

Code	Page
167 480 336	522
167 480 337	522
167 480 338	522
167 480 339	523
167 480 427	541
167 480 428	541
167 480 452	500
167 480 453	500
167 480 454	500
167 480 455	500
167 480 456	500
167 480 457	500
167 480 458	500
167 480 476	541
167 480 519	512
167 480 527	501
167 480 528	501
167 480 529	501
167 480 530	501
167 480 531	501
167 480 532	501
167 480 533	501
167 480 537	560
167 480 538	560
167 480 539	560
167 480 540	560
167 480 541	501
167 480 542	501
167 480 546	501
167 480 547	501
167 480 548	501
167 480 549	501
167 480 550	501
167 480 551	501
167 480 577	541
167 480 680	13
167 480 681	13
167 480 682	13
167 480 683	13
167 480 684	13
167 480 685	13
167 480 686	13
167 480 687	13
167 480 688	13
167 480 689	13
167 480 690	13
167 480 691	13
167 480 692	13
167 480 693	13
167 480 694	13
167 480 695	13
167 480 696	13
167 480 697	13
167 480 710	12
167 480 711	12
167 480 712	12
167 480 713	12
167 480 714	12
167 480 715	12
167 480 716	12
167 480 717	12
167 480 718	12
167 480 719	12
167 480 720	12
167 480 721	12
167 480 722	12
167 480 723	12
167 480 724	12

Index

Code	Page
167 480 725	12
167 480 726	12
167 480 727	12
167 480 728	12
167 480 729	12
167 480 730	12
167 480 731	12
167 480 732	12
167 480 786	500
167 480 787	500
167 480 788	500
167 480 789	500
167 480 790	500
167 480 791	500
167 480 806	499
167 480 807	499
167 480 808	499
167 480 809	499
167 480 810	499
167 480 811	499
167 480 812	499
167 480 813	499
167 480 814	499
167 480 815	499
167 480 816	499
167 480 817	499
167 480 818	499
167 480 819	499
167 480 875	499
167 480 876	499
167 480 877	499
167 480 878	499
167 480 879	499
167 480 880	499
167 480 883	499
167 480 884	499
167 480 885	499
167 480 886	499
167 480 887	499
167 480 888	499
167 480 891	510
167 480 892	510
167 480 893	510
167 480 896	510
167 480 897	510
167 480 898	510
167 480 901	512
167 480 902	512
167 480 904	512
167 480 905	512
167 480 909	522
167 480 910	522
167 480 911	522
167 480 912	522
167 480 913	522
167 480 914	522
167 480 917	522
167 480 918	522
167 480 919	522
167 480 920	522
167 480 921	522
167 480 922	522
167 480 931	522
167 480 932	522
167 481 027	12
167 481 028	12
167 481 029	12
167 481 090	514

Code	Page
167 481 091	514
167 481 092	514
167 481 093	514
167 481 125	558
167 481 126	558
167 481 127	558
167 481 128	558
167 481 129	558
167 481 130	558
167 481 131	558
167 481 135	558
167 481 136	558
167 481 137	558
167 481 138	558
167 481 139	558
167 481 140	558
167 481 141	558
167 481 145	514
167 481 146	514
167 481 147	514
167 481 148	514
167 481 150	514
167 481 151	514
167 481 152	514
167 481 153	514
167 481 155	514
167 481 156	514
167 481 157	514
167 481 158	514
167 481 160	514
167 481 161	514
167 481 162	514
167 481 163	514
167 481 165	558
167 481 166	558
167 481 167	558
167 481 168	558
167 481 169	558
167 481 170	558
167 481 175	539
167 481 176	539
167 481 177	539
167 481 178	539
167 481 179	539
167 481 180	539
167 481 552	541
167 481 553	541
167 481 554	541
167 481 555	541
167 481 556	541
167 481 557	541
167 481 570	514
167 481 571	514
167 481 572	514
167 481 573	514
167 481 711	348
167 481 712	348
167 481 713	348
167 481 714	348
167 481 715	348
167 481 716	348
167 481 717	348
167 481 718	348
167 481 719	348
167 481 720	348
167 481 721	348
167 481 722	348
167 481 723	348

Code	Page
167 481 724	348
167 481 725	348
167 481 726	348
167 481 727	348
167 481 728	348
167 481 977	536
167 481 978	536
167 481 979	536
167 481 980	536
167 481 981	536
167 481 982	536
167 482 137	502
167 482 138	502
167 482 139	502
167 482 140	502
167 482 141	502
167 482 142	502
167 482 148	502
167 482 149	502
167 482 150	502
167 482 151	502
167 482 152	502
167 482 153	502
167 482 159	503
167 482 160	503
167 482 161	503
167 482 162	503
167 482 163	503
167 482 164	503
167 482 170	503
167 482 171	503
167 482 172	503
167 482 173	503
167 482 174	503
167 482 175	503
167 482 190	503
167 482 191	503
167 482 192	503
167 482 193	503
167 482 194	503
167 482 195	503
167 482 202	503
167 482 203	503
167 482 204	503
167 482 205	503
167 482 206	503
167 482 207	503
167 482 214	504
167 482 215	504
167 482 216	504
167 482 217	504
167 482 218	504
167 482 219	504
167 482 226	504
167 482 227	504
167 482 228	504
167 482 229	504
167 482 230	504
167 482 231	504
167 482 479	495
167 482 480	495
167 482 481	495
167 482 482	495
167 482 546	501
167 482 547	501
167 482 548	501
167 482 549	501
167 482 550	501

Index

Code	Page	Code	Page	Code	Page
167 482 551	501	167 482 904	548	167 483 342	532
167 482 626	94	167 482 905	548	167 483 343	532
167 482 627	94	167 482 906	548	167 483 344	532
167 482 628	94	167 482 907	548	167 483 345	532
167 482 629	94	167 482 908	548	167 483 346	532
167 482 630	94	167 482 909	548	167 483 347	532
167 482 631	94	167 482 911	548	167 483 522	531
167 482 635	95	167 482 912	548	167 483 523	531
167 482 636	95	167 482 913	548	167 483 524	531
167 482 637	95	167 482 914	548	167 483 525	531
167 482 638	95	167 482 915	548	167 483 526	531
167 482 639	95	167 482 916	548	167 483 527	531
167 482 640	95	167 482 917	548	167 483 882	532
167 482 653	96	167 482 922	548	167 483 883	532
167 482 654	96	167 482 923	548	167 483 884	532
167 482 655	96	167 482 924	548	167 483 885	532
167 482 656	96	167 482 925	548	167 483 886	532
167 482 657	96	167 482 926	548	167 483 887	532
167 482 658	96	167 482 927	548	167 484 012	522
167 482 662	96	167 482 928	548	167 484 013	522
167 482 663	96	167 482 929	548	167 484 014	522
167 482 664	96	167 482 930	548	167 484 015	522
167 482 665	96	167 482 931	548	167 484 016	522
167 482 666	96	167 482 938	549	167 484 017	522
167 482 667	96	167 482 939	549	167 484 025	541
167 482 671	95	167 482 940	549	167 484 026	541
167 482 672	95	167 482 941	549	167 484 027	541
167 482 673	95	167 482 942	549	167 484 028	541
167 482 674	95	167 482 945	549	167 484 029	541
167 482 675	95	167 482 946	549	167 484 030	541
167 482 676	95	167 482 947	549	167 484 031	541
167 482 680	94	167 482 948	549	167 484 035	541
167 482 681	94	167 482 949	549	167 484 036	541
167 482 682	94	167 482 950	549	167 484 037	541
167 482 683	94	167 482 951	549	167 484 038	541
167 482 684	94	167 482 952	549	167 484 039	541
167 482 685	94	167 482 953	549	167 484 040	541
167 482 712	550	167 482 956	549	167 484 041	541
167 482 713	550	167 482 957	549	167 484 065	550
167 482 714	550	167 482 958	549	167 484 066	550
167 482 715	550	167 482 959	549	167 484 067	550
167 482 716	550	167 482 960	549	167 484 068	550
167 482 717	550	167 482 961	549	167 484 069	550
167 482 718	550	167 482 966	548	167 484 070	550
167 482 719	550	167 482 967	548	167 484 071	550
167 482 720	550	167 482 968	548	167 484 072	550
167 482 876	490	167 482 969	548	167 484 073	550
167 482 877	490	167 482 970	548	167 484 076	491
167 482 878	490	167 482 971	548	167 484 077	491
167 482 879	490	167 482 972	548	167 484 078	491
167 482 880	490	167 483 226	518	167 484 079	491
167 482 881	490	167 483 227	518	167 484 080	491
167 482 882	490	167 483 228	518	167 484 081	491
167 482 883	490	167 483 229	518	167 484 082	491
167 482 884	490	167 483 230	518	167 484 083	491
167 482 888	490	167 483 231	518	167 484 084	491
167 482 889	490	167 483 232	518	167 484 088	491
167 482 890	490	167 483 233	518	167 484 089	491
167 482 891	490	167 483 234	518	167 484 090	491
167 482 892	490	167 483 235	518	167 484 091	491
167 482 893	490	167 483 236	518	167 484 092	491
167 482 894	490	167 483 237	518	167 484 093	491
167 482 895	490	167 483 238	518	167 484 094	491
167 482 896	490	167 483 239	518	167 484 095	491
167 482 900	548	167 483 251	519	167 484 096	491
167 482 901	548	167 483 252	519	167 484 100	491
167 482 902	548	167 483 253	519	167 484 101	491
167 482 903	548	167 483 254	519	167 484 102	491

Index

Code	Page
167 484 103	491
167 484 104	491
167 484 105	491
167 484 110	97
167 484 111	97
167 484 125	491
167 484 126	491
167 484 127	491
167 484 128	491
167 484 129	491
167 484 130	491
167 484 131	491
167 484 132	491
167 484 133	491
167 484 135	491
167 484 136	491
167 484 137	491
167 484 138	491
167 484 139	491
167 484 140	491
167 484 141	491
167 484 142	491
167 484 143	491
167 484 160	549
167 484 161	549
167 484 162	549
167 484 163	549
167 484 164	549
167 484 165	549
167 484 259	518
167 484 260	518
167 484 261	518
167 484 262	518
167 484 263	518
167 484 264	518
167 484 265	519
167 484 266	519
167 484 267	519
167 484 268	519
167 484 269	519
167 484 270	519
167 484 271	517
167 484 272	517
167 484 273	517
167 484 274	517
167 484 275	517
167 484 276	517
167 484 277	517
167 484 278	517
167 484 279	517
167 484 280	518
167 484 281	518
167 484 282	518
167 484 283	519
167 484 284	519
167 484 285	519
167 484 286	517
167 484 287	517
167 484 288	517
167 484 289	517
167 484 290	517
167 484 291	517
167 484 292	517
167 484 293	517
167 484 294	517
167 484 295	520
167 484 296	520
167 484 297	520

Code	Page
167 484 298	520
167 484 299	520
167 484 376	495
167 484 377	495
167 484 378	495
167 484 379	495
167 484 380	495
167 484 381	495
167 484 402	532
167 484 403	532
167 484 404	532
167 484 405	532
167 484 406	532
167 484 407	532
167 484 418	550
167 484 419	550
167 484 420	550
167 484 442	495
167 484 443	495
167 484 444	495
167 484 445	495
167 484 446	495
167 484 447	495
167 484 488	495
167 484 489	495
167 484 490	495
167 484 491	495
167 484 492	495
167 484 493	495
167 484 542	495
167 484 543	495
167 484 544	495
167 484 545	495
167 484 546	495
167 484 547	495
167 484 576	495
167 484 577	495
167 484 578	495
167 484 579	495
167 484 580	495
167 484 581	495
167 484 588	495
167 484 589	495
167 484 590	495
167 484 591	495
167 484 592	495
167 484 593	495
167 484 642	497
167 484 643	497
167 484 644	497
167 484 645	497
167 484 646	497
167 484 647	497
167 484 688	497
167 484 689	497
167 484 690	497
167 484 691	497
167 484 692	497
167 484 693	497
167 484 742	497
167 484 743	497
167 484 744	497
167 484 745	497
167 484 746	497
167 484 747	497
167 484 788	497
167 484 789	497
167 484 790	497

Code	Page
167 484 791	497
167 484 792	497
167 484 793	497
167 484 802	493
167 484 803	493
167 484 804	493
167 484 805	493
167 484 806	493
167 484 807	493
167 484 812	493
167 484 813	493
167 484 814	493
167 484 815	493
167 484 816	493
167 484 817	493
167 484 822	493
167 484 823	493
167 484 824	493
167 484 825	493
167 484 826	493
167 484 827	493
167 484 832	493
167 484 833	493
167 484 834	493
167 484 835	493
167 484 836	493
167 484 837	493
167 484 882	494
167 484 883	494
167 484 884	494
167 484 885	494
167 484 886	494
167 484 887	494
167 484 892	494
167 484 893	494
167 484 894	494
167 484 895	494
167 484 896	494
167 484 897	494
167 484 902	494
167 484 903	494
167 484 904	494
167 484 905	494
167 484 906	494
167 484 907	494
167 484 912	494
167 484 913	494
167 484 914	494
167 484 915	494
167 484 916	494
167 484 917	494
167 484 941	496
167 484 942	496
167 484 943	496
167 484 944	496
167 484 945	498
167 484 946	498
167 484 947	498
167 484 948	498
167 484 992	528
167 484 993	528
167 484 994	528
167 484 995	528
167 484 996	528
167 484 997	528
167 485 151	556
167 485 152	556
167 485 153	556

Index

Code	Page	Code	Page	Code	Page
167 485 154	556	167 485 289	563	167 514 064	118
167 485 155	556	167 485 291	563	167 514 065	118
167 485 156	556	167 485 292	563	167 514 066	118
167 485 157	556	167 485 293	563	167 514 067	118
167 485 158	556	167 485 294	563	167 514 072	366
167 485 159	556	167 485 295	563	167 514 073	366
167 485 201	555	167 485 296	563	167 514 074	366
167 485 202	555	167 485 297	563	167 514 075	366
167 485 203	555	167 485 298	563	167 514 076	366
167 485 204	555	167 485 299	563	167 514 077	366
167 485 205	555	167 485 351	556	167 514 102	119
167 485 206	555	167 485 352	556	167 514 103	119
167 485 207	555	167 485 353	556	167 514 104	119
167 485 208	555	167 485 354	556	167 514 105	119
167 485 209	555	167 485 355	556	167 514 106	119
167 485 211	555	167 485 356	556	167 514 107	119
167 485 212	555	167 485 357	556	167 514 112	119
167 485 213	555	167 485 358	556	167 514 113	119
167 485 214	555	167 485 359	556	167 514 114	119
167 485 215	555	167 485 361	564	167 514 115	119
167 485 216	555	167 485 362	564	167 514 116	119
167 485 217	555	167 485 363	564	167 514 117	119
167 485 218	555	167 485 364	564	167 514 122	366
167 485 219	555	167 485 365	564	167 514 123	366
167 485 231	556	167 485 366	564	167 514 124	366
167 485 232	556	167 485 371	492	167 514 125	366
167 485 233	556	167 485 373	492	167 514 126	366
167 485 234	556	167 485 381	492	167 514 127	366
167 485 235	556	167 485 383	492	167 514 132	119
167 485 236	556	167 485 911	533	167 514 133	119
167 485 237	556	167 485 912	533	167 514 134	119
167 485 238	556	167 485 913	533	167 514 135	119
167 485 239	556	167 485 914	533	167 514 136	119
167 485 241	556	167 485 915	533	167 514 137	119
167 485 242	556	167 485 916	533	167 514 162	119
167 485 243	556	167 485 917	533	167 514 163	119
167 485 244	556	167 485 922	534	167 514 164	119
167 485 245	556	167 485 923	534	167 514 165	119
167 485 246	556	167 485 924	534	167 514 166	119
167 485 247	556	167 485 927	534	167 514 167	119
167 485 248	556	167 485 928	534	167 514 172	366
167 485 249	556	167 485 929	534	167 514 173	366
167 485 261	562	167 514 002	118	167 514 174	366
167 485 262	562	167 514 003	118	167 514 175	366
167 485 263	562	167 514 004	118	167 514 176	366
167 485 264	562	167 514 005	118	167 514 177	366
167 485 265	562	167 514 006	118	167 514 212	118
167 485 266	562	167 514 007	118	167 514 213	118
167 485 267	562	167 514 012	118	167 514 214	118
167 485 268	562	167 514 013	118	167 514 215	118
167 485 269	562	167 514 014	118	167 514 216	118
167 485 271	562	167 514 015	118	167 514 217	118
167 485 272	562	167 514 016	118	167 514 232	118
167 485 273	562	167 514 017	118	167 514 233	118
167 485 274	562	167 514 022	366	167 514 234	118
167 485 275	562	167 514 023	366	167 514 235	118
167 485 276	562	167 514 024	366	167 514 236	118
167 485 277	562	167 514 025	366	167 514 237	118
167 485 278	562	167 514 026	366	167 514 312	120
167 485 279	562	167 514 027	366	167 514 313	120
167 485 281	563	167 514 032	118	167 514 314	120
167 485 282	563	167 514 033	118	167 514 315	120
167 485 283	563	167 514 034	118	167 514 316	120
167 485 284	563	167 514 035	118	167 514 317	120
167 485 285	563	167 514 036	118	167 514 332	120
167 485 286	563	167 514 037	118	167 514 333	120
167 485 287	563	167 514 062	118	167 514 334	120
167 485 288	563	167 514 063	118	167 514 335	120

Index

Code	Page
167 514 336	120
167 514 337	120
167 515 002	121
167 515 003	121
167 515 004	121
167 515 005	121
167 515 006	121
167 515 007	121
167 515 012	121
167 515 013	121
167 515 014	121
167 515 015	121
167 515 016	121
167 515 017	121
167 515 022	367
167 515 023	367
167 515 024	367
167 515 025	367
167 515 026	367
167 515 027	367
167 515 032	121
167 515 033	121
167 515 034	121
167 515 035	121
167 515 036	121
167 515 037	121
167 515 062	121
167 515 063	121
167 515 064	121
167 515 065	121
167 515 066	121
167 515 067	121
167 515 072	367
167 515 073	367
167 515 074	367
167 515 075	367
167 515 076	367
167 515 077	367
167 515 102	122
167 515 103	122
167 515 104	122
167 515 105	122
167 515 106	122
167 515 107	122
167 515 112	122
167 515 113	122
167 515 114	122
167 515 115	122
167 515 116	122
167 515 117	122
167 515 122	368
167 515 123	368
167 515 124	368
167 515 125	368
167 515 126	368
167 515 127	368
167 515 128	368
167 515 129	368
167 515 130	368
167 515 131	368
167 515 132	368
167 515 133	368
167 515 134	368
167 515 135	368
167 515 136	368
167 515 137	368
167 515 138	368
167 515 139	368
167 515 140	368
167 515 141	368
167 515 142	368
167 515 143	368
167 515 144	368
167 515 145	368
167 515 146	368
167 515 147	368
167 515 148	368
167 515 149	368
167 515 150	368
167 515 151	368
167 515 152	368
167 515 153	368
167 515 154	368
167 515 155	368
167 515 156	368
167 515 157	368
167 515 158	368
167 515 159	368
167 515 160	368
167 515 161	368
167 515 162	368
167 515 163	368
167 515 164	368
167 515 165	368
167 515 166	368
167 515 167	368

Code	Page
167 515 172	368
167 515 173	368
167 515 174	368
167 515 175	368
167 515 176	368
167 515 177	368
167 517 102	123
167 517 103	123
167 517 104	123
167 517 105	123
167 517 106	123
167 517 107	123
167 517 112	123
167 517 113	123
167 517 114	123
167 517 115	123
167 517 116	123
167 517 117	123
167 517 122	368
167 517 123	368
167 517 124	368
167 517 125	368
167 517 126	368
167 517 127	368
167 517 132	123
167 517 133	123
167 517 134	123
167 517 135	123
167 517 136	123
167 517 137	123
167 517 162	123
167 517 163	123
167 517 164	123
167 517 165	123
167 517 166	123
167 517 167	123
167 517 172	368
167 517 173	368
167 517 174	368
167 517 175	368
167 517 176	368
167 517 177	368
167 517 712	124
167 517 713	124
167 517 714	124
167 517 715	124
167 517 716	124
167 517 717	124
167 517 732	124
167 517 733	124
167 517 734	124
167 517 735	124
167 517 736	124
167 517 737	124
167 517 912	126
167 517 913	126
167 517 914	126
167 517 915	126
167 517 916	126
167 517 917	126
167 517 922	369
167 517 923	369
167 517 924	369
167 517 925	369
167 517 926	369
167 517 927	369
167 517 932	126
167 517 933	126

Code	Page
167 517 934	126
167 517 935	126
167 517 936	126
167 517 937	126
167 517 972	369
167 517 973	369
167 517 974	369
167 517 975	369
167 517 976	369
167 517 977	369
167 519 101	127
167 519 103	127
167 519 104	127
167 519 107	127
167 519 108	127
167 519 109	127
167 519 112	127
167 519 118	127
167 519 119	127
167 519 120	127
167 519 125	127
167 519 126	127
167 519 127	127
167 519 201	374
167 519 203	374
167 519 204	374
167 519 207	374
167 519 208	374
167 519 209	374
167 519 212	374
167 519 218	374
167 519 219	374
167 519 220	374
167 519 225	374
167 519 226	374
167 519 227	374
167 519 301	127
167 519 303	127
167 519 304	127
167 519 307	127
167 519 308	127
167 519 309	127
167 519 312	127
167 519 318	127
167 519 319	127
167 519 320	127
167 519 325	127
167 519 326	127
167 519 327	127
167 519 701	374
167 519 703	374
167 519 704	374
167 519 707	374
167 519 708	374
167 519 709	374
167 519 712	374
167 519 718	374
167 519 719	374
167 519 720	374
167 519 725	374
167 519 726	374
167 519 727	374
167 523 401	99
167 523 402	99
167 523 411	99
167 523 412	99
167 523 441	99
167 523 442	99

Index

Code	Page
167 523 451	99
167 523 452	99
167 523 482	100
167 523 492	100
167 543 001	101
167 543 002	101
167 543 003	101
167 543 004	101
167 543 005	101
167 543 006	101
167 543 007	101
167 543 011	101
167 543 012	101
167 543 013	101
167 543 014	101
167 543 015	101
167 543 016	101
167 543 017	101
167 543 021	103
167 543 022	103
167 543 023	103
167 543 024	103
167 543 025	103
167 543 026	103
167 543 027	103
167 543 031	103
167 543 032	103
167 543 033	103
167 543 034	103
167 543 035	103
167 543 036	103
167 543 037	103
167 543 062	104
167 543 063	104
167 543 064	104
167 543 065	104
167 543 066	104
167 543 067	104
167 543 072	104
167 543 073	104
167 543 074	104
167 543 075	104
167 543 076	104
167 543 077	104
167 543 081	102
167 543 082	102
167 543 083	102
167 543 084	102
167 543 085	102
167 543 086	102
167 543 087	102
167 543 091	102
167 543 092	102
167 543 093	102
167 543 094	102
167 543 095	102
167 543 096	102
167 543 097	102
167 543 102	105
167 543 103	105
167 543 104	105
167 543 105	105
167 543 106	105
167 543 107	105
167 543 112	105
167 543 113	105
167 543 114	105
167 543 115	105

Code	Page
167 543 116	105
167 543 117	105
167 543 122	106
167 543 123	106
167 543 124	106
167 543 125	106
167 543 126	106
167 543 127	106
167 543 132	106
167 543 133	106
167 543 134	106
167 543 135	106
167 543 136	106
167 543 137	106
167 543 201	107
167 543 202	107
167 543 203	107
167 543 204	107
167 543 205	107
167 543 206	107
167 543 207	107
167 543 211	107
167 543 212	107
167 543 213	107
167 543 214	107
167 543 215	107
167 543 216	107
167 543 217	107
167 543 221	109
167 543 222	109
167 543 223	109
167 543 224	109
167 543 225	109
167 543 226	109
167 543 227	109
167 543 231	109
167 543 232	109
167 543 233	109
167 543 234	109
167 543 235	109
167 543 236	109
167 543 237	109
167 543 262	110
167 543 263	110
167 543 264	110
167 543 265	110
167 543 266	110
167 543 267	110
167 543 272	110
167 543 273	110
167 543 274	110
167 543 275	110
167 543 276	110
167 543 277	110
167 543 281	108
167 543 282	108
167 543 283	108
167 543 284	108
167 543 285	108
167 543 286	108
167 543 287	108
167 543 291	108
167 543 292	108
167 543 293	108
167 543 294	108
167 543 295	108
167 543 296	108
167 543 297	108

Code	Page
167 543 302	111
167 543 303	111
167 543 304	111
167 543 305	111
167 543 306	111
167 543 307	111
167 543 312	111
167 543 313	111
167 543 314	111
167 543 315	111
167 543 316	111
167 543 317	111
167 543 322	112
167 543 323	112
167 543 324	112
167 543 325	112
167 543 326	112
167 543 327	112
167 543 332	112
167 543 333	112
167 543 334	112
167 543 335	112
167 543 336	112
167 543 337	112
167 543 561	113
167 543 562	113
167 543 563	113
167 543 564	113
167 543 565	113
167 543 566	113
167 543 567	113
167 543 571	113
167 543 572	113
167 543 573	113
167 543 574	113
167 543 575	113
167 543 576	113
167 543 577	113
167 543 581	115
167 543 582	115
167 543 583	115
167 543 584	115
167 543 585	115
167 543 586	115
167 543 587	115
167 543 591	115
167 543 592	115
167 543 593	115
167 543 594	115
167 543 595	115
167 543 596	115
167 543 597	115
167 543 602	114
167 543 603	114
167 543 604	114
167 543 605	114
167 543 606	114
167 543 607	114
167 543 612	114
167 543 613	114
167 543 614	114
167 543 615	114
167 543 616	114
167 543 617	114
167 543 622	116
167 543 623	116
167 543 624	116
167 543 625	116

Index

Code	Page
167 543 626	116
167 543 627	116
167 543 632	116
167 543 633	116
167 543 634	116
167 543 635	116
167 543 636	116
167 543 637	116
167 546 001	93
167 546 002	93
167 546 003	93
167 546 004	93
167 546 005	93
167 546 006	93
167 546 007	93
167 546 008	93
167 546 009	93
167 546 010	93
167 546 011	93
167 546 012	93
167 546 013	93
167 546 014	93
167 546 015	93
167 546 016	93
167 546 017	93
167 546 018	93
167 546 019	93
167 546 020	93
167 546 021	80
167 546 022	80
167 546 023	80
167 546 024	80
167 546 025	80
167 546 026	80
167 546 027	80
167 546 031	80
167 546 032	80
167 546 033	80
167 546 034	80
167 546 035	80
167 546 036	80
167 546 037	80
167 546 041	79
167 546 042	79
167 546 043	79
167 546 044	79
167 546 045	79
167 546 046	79
167 546 047	79
167 546 048	79
167 546 049	79
167 546 050	79
167 546 051	79
167 546 052	79
167 546 053	79
167 546 054	79
167 546 055	79
167 546 056	79
167 546 057	79
167 546 058	79
167 546 059	79
167 546 060	79
167 546 066	84
167 546 067	84
167 546 068	84
167 546 069	84
167 546 070	84
167 546 076	84

Code	Page
167 546 077	84
167 546 078	84
167 546 079	84
167 546 080	84
167 546 126	88
167 546 127	88
167 546 136	88
167 546 137	88
167 546 142	86
167 546 143	86
167 546 144	86
167 546 145	86
167 546 146	86
167 546 147	86
167 546 152	86
167 546 153	86
167 546 154	86
167 546 155	86
167 546 156	86
167 546 157	86
167 546 161	85
167 546 162	85
167 546 163	85
167 546 164	85
167 546 165	85
167 546 166	85
167 546 167	85
167 546 171	85
167 546 172	85
167 546 173	85
167 546 174	85
167 546 175	85
167 546 176	85
167 546 177	85
167 546 182	90
167 546 183	90
167 546 184	90
167 546 185	90
167 546 186	90
167 546 187	90
167 546 192	90
167 546 193	90
167 546 194	90
167 546 195	90
167 546 196	90
167 546 197	90
167 546 262	83
167 546 263	83
167 546 264	83
167 546 265	83
167 546 266	83
167 546 267	83
167 546 272	83
167 546 273	83
167 546 274	83
167 546 275	83
167 546 276	83
167 546 277	83
167 546 282	87
167 546 283	87
167 546 284	87
167 546 285	87
167 546 286	87
167 546 287	87
167 546 288	87
167 546 289	87
167 546 290	87
167 546 292	87

Code	Page
167 546 293	87
167 546 294	87
167 546 295	87
167 546 296	87
167 546 297	87
167 546 298	87
167 546 299	87
167 546 300	87
167 546 308	88
167 546 309	88
167 546 310	88
167 546 318	88
167 546 319	88
167 546 320	88
167 546 321	81
167 546 322	81
167 546 323	81
167 546 324	81
167 546 325	81
167 546 326	81
167 546 327	81
167 546 331	81
167 546 332	81
167 546 333	81
167 546 334	81
167 546 335	81
167 546 336	81
167 546 337	81
167 546 401	78
167 546 402	78
167 546 403	78
167 546 404	78
167 546 405	78
167 546 406	78
167 546 407	78
167 546 408	78
167 546 409	78
167 546 410	78
167 546 411	78
167 546 412	78
167 546 413	78
167 546 414	78
167 546 415	78
167 546 416	78
167 546 417	78
167 546 418	78
167 546 419	78
167 546 420	78
167 546 421	91
167 546 422	91
167 546 423	91
167 546 424	91
167 546 425	91
167 546 426	91
167 546 427	91
167 546 428	91
167 546 429	91
167 546 430	91
167 546 431	91
167 546 432	91
167 546 433	91
167 546 434	91
167 546 435	91
167 546 436	91
167 546 437	91
167 546 438	91
167 546 439	91
167 546 440	91

Index

Code	Page	Code	Page	Code	Page
167 546 442	82	167 546 624	361	167 546 918	364
167 546 443	82	167 546 625	361	167 546 919	364
167 546 444	82	167 546 626	361	167 546 920	364
167 546 445	82	167 546 627	361	167 561 001	138
167 546 446	82	167 546 628	361	167 561 002	138
167 546 447	82	167 546 629	361	167 561 003	138
167 546 448	82	167 546 630	361	167 561 004	138
167 546 449	82	167 546 631	361	167 561 005	138
167 546 450	82	167 546 632	361	167 561 006	138
167 546 452	82	167 546 633	361	167 561 007	138
167 546 453	82	167 546 634	361	167 561 008	138
167 546 454	82	167 546 635	361	167 561 009	138
167 546 455	82	167 546 636	361	167 561 010	138
167 546 456	82	167 546 637	361	167 561 011	138
167 546 457	82	167 546 638	361	167 561 012	138
167 546 458	82	167 546 639	361	167 561 013	138
167 546 459	82	167 546 640	361	167 561 014	138
167 546 460	82	167 546 662	362	167 561 015	138
167 546 462	92	167 546 663	362	167 561 016	138
167 546 463	92	167 546 664	362	167 561 017	138
167 546 464	92	167 546 665	362	167 561 018	138
167 546 465	92	167 546 666	362	167 561 019	138
167 546 466	92	167 546 667	362	167 561 020	138
167 546 467	92	167 546 668	362	167 561 021	139
167 546 468	92	167 546 669	362	167 561 022	139
167 546 469	92	167 546 670	362	167 561 023	139
167 546 470	92	167 546 672	362	167 561 024	139
167 546 472	92	167 546 673	362	167 561 025	139
167 546 473	92	167 546 674	362	167 561 026	139
167 546 474	92	167 546 675	362	167 561 027	139
167 546 475	92	167 546 676	362	167 561 031	139
167 546 476	92	167 546 677	362	167 561 032	139
167 546 477	92	167 546 678	362	167 561 033	139
167 546 478	92	167 546 679	362	167 561 034	139
167 546 479	92	167 546 680	362	167 561 035	139
167 546 480	92	167 546 808	89	167 561 036	139
167 546 482	365	167 546 809	89	167 561 037	139
167 546 483	365	167 546 810	89	167 561 041	138
167 546 484	365	167 546 818	89	167 561 042	138
167 546 485	365	167 546 819	89	167 561 043	138
167 546 486	365	167 546 820	89	167 561 044	138
167 546 487	365	167 546 828	363	167 561 045	138
167 546 488	365	167 546 829	363	167 561 046	138
167 546 489	365	167 546 830	363	167 561 047	138
167 546 490	365	167 546 838	363	167 561 048	138
167 546 601	360	167 546 839	363	167 561 049	138
167 546 602	360	167 546 840	363	167 561 050	138
167 546 603	360	167 546 888	363	167 561 051	138
167 546 604	360	167 546 889	363	167 561 052	138
167 546 605	360	167 546 890	363	167 561 053	138
167 546 606	360	167 546 898	363	167 561 054	138
167 546 607	360	167 546 899	363	167 561 055	138
167 546 608	360	167 546 900	363	167 561 056	138
167 546 609	360	167 546 902	364	167 561 057	138
167 546 610	360	167 546 903	364	167 561 058	138
167 546 611	360	167 546 904	364	167 561 059	138
167 546 612	360	167 546 905	364	167 561 060	138
167 546 613	360	167 546 906	364	167 561 066	140
167 546 614	360	167 546 907	364	167 561 067	140
167 546 615	360	167 546 908	364	167 561 068	140
167 546 616	360	167 546 909	364	167 561 069	140
167 546 617	360	167 546 910	364	167 561 070	140
167 546 618	360	167 546 912	364	167 561 076	140
167 546 619	360	167 546 913	364	167 561 077	140
167 546 620	360	167 546 914	364	167 561 078	140
167 546 621	361	167 546 915	364	167 561 079	140
167 546 622	361	167 546 916	364	167 561 080	140
167 546 623	361	167 546 917	364	167 561 082	141

Index

Code	Page
167 561 083	141
167 561 084	141
167 561 085	141
167 561 086	141
167 561 087	141
167 561 088	141
167 561 089	141
167 561 090	141
167 561 092	141
167 561 093	141
167 561 094	141
167 561 095	141
167 561 096	141
167 561 097	141
167 561 098	141
167 561 099	141
167 561 100	141
167 561 182	139
167 561 183	139
167 561 184	139
167 561 185	139
167 561 186	139
167 561 187	139
167 561 192	139
167 561 193	139
167 561 194	139
167 561 195	139
167 561 196	139
167 561 197	139
167 561 201	379
167 561 202	379
167 561 203	379
167 561 204	379
167 561 205	379
167 561 206	379
167 561 207	379
167 561 208	379
167 561 209	379
167 561 210	379
167 561 211	379
167 561 212	379
167 561 213	379
167 561 214	379
167 561 215	379
167 561 216	379
167 561 217	379
167 561 218	379
167 561 219	379
167 561 220	379
167 561 221	379
167 561 222	379
167 561 223	379
167 561 224	379
167 561 225	379
167 561 226	379
167 561 227	379
167 561 228	379
167 561 229	379
167 561 230	379
167 561 231	379
167 561 232	379
167 561 233	379
167 561 234	379
167 561 235	379
167 561 236	379
167 561 237	379
167 561 238	379
167 561 239	379

Code	Page
167 561 240	379
167 561 242	380
167 561 243	380
167 561 244	380
167 561 245	380
167 561 246	380
167 561 247	380
167 561 248	380
167 561 249	380
167 561 250	380
167 561 252	380
167 561 253	380
167 561 254	380
167 561 255	380
167 561 256	380
167 561 257	380
167 561 258	380
167 561 259	380
167 561 260	380
167 561 428	140
167 561 429	140
167 561 430	140
167 561 438	140
167 561 439	140
167 561 440	140
167 562 001	142
167 562 002	142
167 562 003	142
167 562 004	142
167 562 005	142
167 562 006	142
167 562 007	142
167 562 008	142
167 562 009	142
167 562 010	142
167 562 011	142
167 562 012	142
167 562 013	142
167 562 014	142
167 562 015	142
167 562 016	142
167 562 017	142
167 562 018	142
167 562 019	142
167 562 020	142
167 562 021	143
167 562 022	143
167 562 023	143
167 562 024	143
167 562 025	143
167 562 026	143
167 562 027	143
167 562 031	143
167 562 032	143
167 562 033	143
167 562 034	143
167 562 035	143
167 562 036	143
167 562 037	143
167 562 041	142
167 562 042	142
167 562 043	142
167 562 044	142
167 562 045	142
167 562 046	142
167 562 047	142
167 562 048	142
167 562 049	142

Code	Page
167 562 050	142
167 562 051	142
167 562 052	142
167 562 053	142
167 562 054	142
167 562 055	142
167 562 056	142
167 562 057	142
167 562 058	142
167 562 059	142
167 562 060	142
167 562 066	144
167 562 067	144
167 562 068	144
167 562 069	144
167 562 070	144
167 562 076	144
167 562 077	144
167 562 078	144
167 562 079	144
167 562 080	144
167 562 082	145
167 562 083	145
167 562 084	145
167 562 085	145
167 562 086	145
167 562 087	145
167 562 088	145
167 562 089	145
167 562 090	145
167 562 092	145
167 562 093	145
167 562 094	145
167 562 095	145
167 562 096	145
167 562 097	145
167 562 098	145
167 562 099	145
167 562 100	145
167 562 182	143
167 562 183	143
167 562 184	143
167 562 185	143
167 562 186	143
167 562 187	143
167 562 192	143
167 562 193	143
167 562 194	143
167 562 195	143
167 562 196	143
167 562 197	143
167 562 201	380
167 562 202	380
167 562 203	380
167 562 204	380
167 562 205	380
167 562 206	380
167 562 207	380
167 562 208	380
167 562 209	380
167 562 210	380
167 562 211	380
167 562 212	380
167 562 213	380
167 562 214	380
167 562 215	380
167 562 216	380
167 562 217	380

Index

Code	Page	Code	Page	Code	Page
167 562 218	380	167 567 045	129	167 567 806	130
167 562 219	380	167 567 046	129	167 567 807	130
167 562 220	380	167 567 047	129	167 567 808	130
167 562 221	381	167 567 048	129	167 567 809	130
167 562 222	381	167 567 049	129	167 567 810	130
167 562 223	381	167 567 050	129	167 567 811	130
167 562 224	381	167 567 051	129	167 567 812	130
167 562 225	381	167 567 052	129	167 567 813	130
167 562 226	381	167 567 053	129	167 567 814	130
167 562 227	381	167 567 054	129	167 567 815	130
167 562 228	381	167 567 055	129	167 567 822	130
167 562 229	381	167 567 062	129	167 567 823	130
167 562 230	381	167 567 063	129	167 567 824	130
167 562 231	381	167 567 064	129	167 567 825	130
167 562 232	381	167 567 065	129	167 567 826	130
167 562 233	381	167 567 066	129	167 567 827	130
167 562 234	381	167 567 067	129	167 567 828	130
167 562 235	381	167 567 068	129	167 567 829	130
167 562 236	381	167 567 069	129	167 567 830	130
167 562 237	381	167 567 070	129	167 567 831	130
167 562 238	381	167 567 071	129	167 567 832	130
167 562 239	381	167 567 072	129	167 567 833	130
167 562 240	381	167 567 073	129	167 567 834	130
167 562 242	381	167 567 074	129	167 567 835	130
167 562 243	381	167 567 075	129	167 567 840	130
167 562 244	381	167 567 202	128	167 567 841	130
167 562 245	381	167 567 203	128	167 567 842	130
167 562 246	381	167 567 204	128	167 567 843	130
167 562 247	381	167 567 205	128	167 567 844	130
167 562 248	381	167 567 206	128	167 567 845	130
167 562 249	381	167 567 207	128	167 567 846	130
167 562 250	381	167 567 208	128	167 567 847	130
167 562 252	381	167 567 209	128	167 567 848	130
167 562 253	381	167 567 210	128	167 568 002	132
167 562 254	381	167 567 242	129	167 568 003	132
167 562 255	381	167 567 243	129	167 568 004	132
167 562 256	381	167 567 244	129	167 568 005	132
167 562 257	381	167 567 245	129	167 568 006	132
167 562 258	381	167 567 246	129	167 568 007	132
167 562 259	381	167 567 247	129	167 568 008	132
167 562 260	381	167 567 248	129	167 568 022	132
167 562 428	144	167 567 249	129	167 568 023	132
167 562 429	144	167 567 250	129	167 568 024	132
167 562 430	144	167 567 402	375	167 568 025	132
167 562 438	144	167 567 403	375	167 568 026	132
167 562 439	144	167 567 404	375	167 568 027	132
167 562 440	144	167 567 405	375	167 568 028	132
167 567 002	128	167 567 406	375	167 568 042	133
167 567 003	128	167 567 407	375	167 568 043	133
167 567 004	128	167 567 408	375	167 568 044	133
167 567 005	128	167 567 422	375	167 568 045	133
167 567 006	128	167 567 423	375	167 568 046	133
167 567 007	128	167 567 424	375	167 568 047	133
167 567 008	128	167 567 425	375	167 568 048	133
167 567 009	128	167 567 426	375	167 568 062	133
167 567 010	128	167 567 427	375	167 568 063	133
167 567 022	128	167 567 428	375	167 568 064	133
167 567 023	128	167 567 502	376	167 568 065	133
167 567 024	128	167 567 503	376	167 568 066	133
167 567 025	128	167 567 504	376	167 568 067	133
167 567 026	128	167 567 505	376	167 568 068	133
167 567 027	128	167 567 506	376	167 568 102	135
167 567 028	128	167 567 507	376	167 568 103	135
167 567 029	128	167 567 508	376	167 568 104	135
167 567 030	128	167 567 802	130	167 568 105	135
167 567 042	129	167 567 803	130	167 568 106	135
167 567 043	129	167 567 804	130	167 568 107	135
167 567 044	129	167 567 805	130	167 568 108	135

Index

Code	Page
167 568 122	135
167 568 123	135
167 568 124	135
167 568 125	135
167 568 126	135
167 568 127	135
167 568 128	135
167 568 142	136
167 568 143	136
167 568 144	136
167 568 145	136
167 568 146	136
167 568 147	136
167 568 148	136
167 568 162	136
167 568 163	136
167 568 164	136
167 568 165	136
167 568 166	136
167 568 167	136
167 568 168	136
167 568 202	132
167 568 203	132
167 568 204	132
167 568 205	132
167 568 206	132
167 568 207	132
167 568 208	132
167 568 242	133
167 568 243	133
167 568 244	133
167 568 245	133
167 568 246	133
167 568 247	133
167 568 248	133
167 568 302	135
167 568 303	135
167 568 304	135
167 568 305	135
167 568 306	135
167 568 307	135
167 568 308	135
167 568 342	136
167 568 343	136
167 568 344	136
167 568 345	136
167 568 346	136
167 568 347	136
167 568 348	136
167 568 402	377
167 568 403	377
167 568 404	377
167 568 405	377
167 568 406	377
167 568 407	377
167 568 408	377
167 568 422	377
167 568 423	377
167 568 424	377
167 568 425	377
167 568 426	377
167 568 427	377
167 568 428	377
167 568 502	378
167 568 503	378
167 568 504	378
167 568 505	378
167 568 506	378

Code	Page
167 568 507	378
167 568 508	378
167 568 522	378
167 568 523	378
167 568 524	378
167 568 525	378
167 568 526	378
167 568 527	378
167 568 528	378
167 568 802	134
167 568 803	134
167 568 804	134
167 568 805	134
167 568 806	134
167 568 807	134
167 568 808	134
167 568 822	134
167 568 823	134
167 568 824	134
167 568 825	134
167 568 826	134
167 568 827	134
167 568 828	134
167 568 840	134
167 568 841	134
167 568 842	134
167 568 843	134
167 568 844	134
167 568 845	134
167 568 846	134
167 568 902	137
167 568 903	137
167 568 904	137
167 568 905	137
167 568 906	137
167 568 907	137
167 568 908	137
167 568 922	137
167 568 923	137
167 568 924	137
167 568 925	137
167 568 926	137
167 568 927	137
167 568 928	137
167 568 942	137
167 568 943	137
167 568 944	137
167 568 945	137
167 568 946	137
167 568 947	137
167 568 948	137
167 591 001	146
167 591 002	146
167 591 003	146
167 591 004	146
167 591 005	146
167 591 006	146
167 591 007	146
167 591 008	146
167 591 009	146
167 591 010	146
167 591 011	146
167 591 012	146
167 591 013	146
167 591 014	146
167 591 015	146
167 591 016	146
167 591 017	146

Code	Page
167 591 018	146
167 591 019	146
167 591 020	146
167 591 041	146
167 591 042	146
167 591 043	146
167 591 044	146
167 591 045	146
167 591 046	146
167 591 047	146
167 591 048	146
167 591 049	146
167 591 050	146
167 591 051	146
167 591 052	146
167 591 053	146
167 591 054	146
167 591 055	146
167 591 056	146
167 591 057	146
167 591 058	146
167 591 059	146
167 591 060	146
167 595 001	147
167 595 002	147
167 595 003	147
167 595 004	147
167 595 005	147
167 595 006	147
167 595 007	147
167 595 008	147
167 595 009	147
167 595 010	147
167 595 011	147
167 595 012	147
167 595 013	147
167 595 014	147
167 595 015	147
167 595 016	147
167 595 017	147
167 595 018	147
167 595 019	147
167 595 020	147
167 595 041	147
167 595 042	147
167 595 043	147
167 595 044	147
167 595 045	147
167 595 046	147
167 595 047	147
167 595 048	147
167 595 049	147
167 595 050	147
167 595 051	147
167 595 052	147
167 595 053	147
167 595 054	147
167 595 055	147
167 595 056	147
167 595 057	147
167 595 058	147
167 595 059	147
167 595 060	147
167 614 012	244
167 614 013	244
167 614 014	244
167 614 015	244
167 614 016	244

Index

Code	Page
167 614 017	244
167 614 112	244
167 614 113	244
167 614 114	244
167 614 115	244
167 614 116	244
167 614 117	244
167 615 012	245
167 615 013	245
167 615 014	245
167 615 015	245
167 615 016	245
167 615 017	245
167 615 112	246
167 615 113	246
167 615 114	246
167 615 115	246
167 615 116	246
167 615 117	246
167 617 112	246
167 617 113	246
167 617 114	246
167 617 115	246
167 617 116	246
167 617 117	246
167 617 712	247
167 617 713	247
167 617 714	247
167 617 715	247
167 617 716	247
167 617 717	247
167 617 912	248
167 617 913	248
167 617 914	248
167 617 915	248
167 617 916	248
167 617 917	248
167 617 922	370
167 617 923	370
167 617 924	370
167 617 925	370
167 617 926	370
167 617 927	370
167 624 012	249
167 624 013	249
167 624 014	249
167 624 015	249
167 624 016	249
167 624 017	249
167 624 032	249
167 624 033	249
167 624 034	249
167 624 035	249
167 624 036	249
167 624 037	249
167 624 112	249
167 624 113	249
167 624 114	249
167 624 115	249
167 624 116	249
167 624 117	249
167 624 132	249
167 624 133	249
167 624 134	249
167 624 135	249
167 624 136	249
167 624 137	249
167 625 012	250

Code	Page
167 625 013	250
167 625 014	250
167 625 015	250
167 625 016	250
167 625 017	250
167 625 032	250
167 625 033	250
167 625 034	250
167 625 035	250
167 625 036	250
167 625 037	250
167 625 112	251
167 625 113	251
167 625 114	251
167 625 115	251
167 625 116	251
167 625 117	251
167 625 132	251
167 625 133	251
167 625 134	251
167 625 135	251
167 625 136	251
167 625 137	251
167 627 112	251
167 627 113	251
167 627 114	251
167 627 115	251
167 627 116	251
167 627 117	251
167 627 132	251
167 627 133	251
167 627 134	251
167 627 135	251
167 627 136	251
167 627 137	251
167 627 712	252
167 627 713	252
167 627 714	252
167 627 715	252
167 627 716	252
167 627 717	252
167 627 732	252
167 627 733	252
167 627 734	252
167 627 735	252
167 627 736	252
167 627 737	252
167 627 912	254
167 627 913	254
167 627 914	254
167 627 915	254
167 627 916	254
167 627 917	254
167 627 922	370
167 627 923	370
167 627 924	370
167 627 925	370
167 627 926	370
167 627 927	370
167 627 932	254
167 627 933	254
167 627 934	254
167 627 935	254
167 627 936	254
167 627 937	254
167 627 972	370
167 627 973	370
167 627 974	370

Code	Page
167 627 975	370
167 627 976	370
167 627 977	370
167 644 012	255
167 644 013	255
167 644 014	255
167 644 015	255
167 644 016	255
167 644 017	255
167 644 032	255
167 644 033	255
167 644 034	255
167 644 035	255
167 644 036	255
167 644 037	255
167 644 112	255
167 644 113	255
167 644 114	255
167 644 115	255
167 644 116	255
167 644 117	255
167 644 132	255
167 644 133	255
167 644 134	255
167 644 135	255
167 644 136	255
167 644 137	255
167 645 012	256
167 645 013	256
167 645 014	256
167 645 015	256
167 645 016	256
167 645 017	256
167 645 032	256
167 645 033	256
167 645 034	256
167 645 035	256
167 645 036	256
167 645 037	256
167 645 112	257
167 645 113	257
167 645 114	257
167 645 115	257
167 645 116	257
167 645 117	257
167 645 132	257
167 645 133	257
167 645 134	257
167 645 135	257
167 645 136	257
167 645 137	257
167 647 112	258
167 647 113	258
167 647 114	258
167 647 115	258
167 647 116	258
167 647 117	258
167 647 132	258
167 647 133	258
167 647 134	258
167 647 135	258
167 647 136	258
167 647 137	258
167 647 712	259
167 647 713	259
167 647 714	259
167 647 715	259
167 647 716	259

Index

Code	Page
167 647 717	259
167 647 732	259
167 647 733	259
167 647 734	259
167 647 735	259
167 647 736	259
167 647 737	259
167 647 912	260
167 647 913	260
167 647 914	260
167 647 915	260
167 647 916	260
167 647 917	260
167 647 922	371
167 647 923	371
167 647 924	371
167 647 925	371
167 647 926	371
167 647 927	371
167 647 932	260
167 647 933	260
167 647 934	260
167 647 935	260
167 647 936	260
167 647 937	260
167 647 972	371
167 647 973	371
167 647 974	371
167 647 975	371
167 647 976	371
167 647 977	371
167 654 012	262
167 654 013	262
167 654 014	262
167 654 015	262
167 654 016	262
167 654 017	262
167 654 032	262
167 654 033	262
167 654 034	262
167 654 035	262
167 654 036	262
167 654 037	262
167 654 112	262
167 654 113	262
167 654 114	262
167 654 115	262
167 654 116	262
167 654 117	262
167 654 132	262
167 654 133	262
167 654 134	262
167 654 135	262
167 654 136	262
167 654 137	262
167 655 012	263
167 655 013	263
167 655 014	263
167 655 015	263
167 655 016	263
167 655 017	263
167 655 032	263
167 655 033	263
167 655 034	263
167 655 035	263
167 655 036	263
167 655 037	263
167 655 112	264

Code	Page
167 655 113	264
167 655 114	264
167 655 115	264
167 655 116	264
167 655 117	264
167 655 132	264
167 655 133	264
167 655 134	264
167 655 135	264
167 655 136	264
167 655 137	264
167 657 112	265
167 657 113	265
167 657 114	265
167 657 115	265
167 657 116	265
167 657 117	265
167 657 132	265
167 657 133	265
167 657 134	265
167 657 135	265
167 657 136	265
167 657 137	265
167 657 712	266
167 657 713	266
167 657 714	266
167 657 715	266
167 657 716	266
167 657 717	266
167 657 732	266
167 657 733	266
167 657 734	266
167 657 735	266
167 657 736	266
167 657 737	266
167 657 912	267
167 657 913	267
167 657 914	267
167 657 915	267
167 657 916	267
167 657 917	267
167 657 922	372
167 657 923	372
167 657 924	372
167 657 925	372
167 657 926	372
167 657 927	372
167 657 932	267
167 657 933	267
167 657 934	267
167 657 935	267
167 657 936	267
167 657 937	267
167 657 972	372
167 657 973	372
167 657 974	372
167 657 975	372
167 657 976	372
167 657 977	372
167 684 012	269
167 684 013	269
167 684 014	269
167 684 015	269
167 684 016	269
167 684 017	269
167 684 032	269
167 684 033	269
167 684 034	269

Code	Page
167 684 035	269
167 684 036	269
167 684 037	269
167 684 052	269
167 684 053	269
167 684 054	269
167 684 055	269
167 684 056	269
167 684 057	269
167 684 062	269
167 684 063	269
167 684 064	269
167 684 065	269
167 684 066	269
167 684 067	269
167 684 112	271
167 684 113	271
167 684 114	271
167 684 115	271
167 684 116	271
167 684 117	271
167 684 132	271
167 684 133	271
167 684 134	271
167 684 135	271
167 684 136	271
167 684 137	271
167 684 152	271
167 684 153	271
167 684 154	271
167 684 155	271
167 684 156	271
167 684 157	271
167 684 162	271
167 684 163	271
167 684 164	271
167 684 165	271
167 684 166	271
167 684 167	271
167 684 212	270
167 684 213	270
167 684 214	270
167 684 215	270
167 684 216	270
167 684 217	270
167 684 232	270
167 684 233	270
167 684 234	270
167 684 235	270
167 684 236	270
167 684 237	270
167 684 312	271
167 684 313	271
167 684 314	271
167 684 315	272
167 684 316	272
167 684 317	272
167 684 332	271
167 684 333	271
167 684 334	271
167 684 335	272
167 684 336	272
167 684 337	272
167 685 012	272
167 685 013	272
167 685 014	272
167 685 015	272
167 685 016	272

Index

Code	Page	Code	Page	Code	Page
167 685 017	272	167 689 301	275	168 519 104	339
167 685 032	272	167 689 303	275	168 519 107	339
167 685 033	272	167 689 304	275	168 519 108	339
167 685 034	272	167 689 307	275	168 519 109	339
167 685 035	272	167 689 308	275	168 519 112	339
167 685 036	272	167 689 309	275	168 519 118	339
167 685 037	272	167 689 312	275	168 519 119	339
167 685 112	273	167 689 318	275	168 519 120	339
167 685 113	273	167 689 319	275	168 519 125	339
167 685 114	273	167 689 320	275	168 519 126	339
167 685 115	273	167 689 325	275	168 519 127	339
167 685 116	273	167 689 326	275	168 519 301	339
167 685 117	273	167 689 327	275	168 519 303	339
167 685 132	273	1674781570	514	168 519 304	339
167 685 133	273	1674781571	514	168 519 307	339
167 685 134	273	1674781572	514	168 519 308	339
167 685 135	273	1674781573	514	168 519 309	339
167 685 136	273	168 480 125	539	168 519 312	339
167 685 137	273	168 480 126	539	168 519 318	339
167 687 112	274	168 480 127	539	168 519 319	339
167 687 113	274	168 480 128	539	168 519 320	339
167 687 114	274	168 480 129	539	168 519 325	339
167 687 115	274	168 480 130	539	168 519 326	339
167 687 116	274	168 480 151	326	168 519 327	339
167 687 117	274	168 480 152	326	168 615 112	340
167 687 132	274	168 480 153	326	168 615 113	340
167 687 133	274	168 480 154	326	168 615 114	340
167 687 134	274	168 480 155	326	168 615 115	340
167 687 135	274	168 480 156	326	168 615 116	340
167 687 136	274	168 480 260	549	168 615 117	340
167 687 137	274	168 480 261	549	168 625 112	340
167 687 152	274	168 480 262	549	168 625 113	340
167 687 153	274	168 480 263	549	168 625 114	340
167 687 154	274	168 480 264	549	168 625 115	340
167 687 155	274	168 480 265	549	168 625 116	340
167 687 156	274	168 480 462	532	168 625 117	340
167 687 157	274	168 480 463	532	168 625 132	340
167 687 162	274	168 480 464	532	168 625 133	340
167 687 163	274	168 480 465	532	168 625 134	340
167 687 164	274	168 480 466	532	168 625 135	340
167 687 165	274	168 480 467	532	168 625 136	340
167 687 166	274	168 480 601	533	168 625 137	340
167 687 167	274	168 480 602	533	168 629 101	343
167 687 922	373	168 480 603	533	168 629 103	343
167 687 923	373	168 480 604	533	168 629 104	343
167 687 924	373	168 480 605	533	168 629 107	343
167 687 925	373	168 480 606	533	168 629 108	343
167 687 926	373	168 480 607	533	168 629 109	343
167 687 927	373	168 480 611	534	168 629 112	343
167 687 972	373	168 480 612	534	168 629 118	343
167 687 973	373	168 480 613	534	168 629 119	343
167 687 974	373	168 480 616	534	168 629 120	343
167 687 975	373	168 480 617	534	168 629 125	343
167 687 976	373	168 480 618	534	168 629 126	343
167 687 977	373	168 515 112	338	168 629 127	343
167 689 101	275	168 515 113	338	168 629 301	343
167 689 103	275	168 515 114	338	168 629 303	343
167 689 104	275	168 515 115	338	168 629 304	343
167 689 107	275	168 515 116	338	168 629 307	343
167 689 108	275	168 515 117	338	168 629 308	343
167 689 109	275	168 515 132	338	168 629 309	343
167 689 112	275	168 515 133	338	168 629 312	343
167 689 118	275	168 515 134	338	168 629 318	343
167 689 119	275	168 515 135	338	168 629 319	343
167 689 120	275	168 515 136	338	168 629 320	343
167 689 125	275	168 515 137	338	168 629 325	343
167 689 126	275	168 519 101	339	168 629 326	343
167 689 127	275	168 519 103	339	168 629 327	343

Index

Code	Page
168 645 112	341
168 645 113	341
168 645 114	341
168 645 115	341
168 645 116	341
168 645 117	341
168 655 112	342
168 655 113	342
168 655 114	342
168 655 115	342
168 655 116	342
168 655 117	342
169 367 626	521
169 367 627	521
169 367 629	521
169 480 050	539
169 480 051	539
169 480 052	539
169 480 053	539
169 480 054	539
169 480 055	539
169 480 101	500
169 480 102	500
169 480 103	500
169 480 104	500
169 480 105	500
169 480 106	500
169 480 110	500
169 480 111	500
169 480 112	500
169 480 113	500
169 480 114	501
169 480 115	501
169 480 116	501
169 480 120	501
169 480 121	501
169 480 122	501
169 480 123	501
169 480 124	501
169 480 125	501
169 480 126	501
169 480 152	500
169 480 153	500
169 480 154	500
169 480 155	500
169 480 156	500
169 480 157	500
169 480 158	500
169 480 162	539
169 480 163	539
169 480 164	539
169 480 165	539
169 480 166	539
169 480 167	539
169 480 175	499
169 480 176	499
169 480 177	499
169 480 178	499
169 480 179	499
169 480 180	499
169 480 250	558
169 480 251	558
169 480 252	558
169 480 253	558
169 480 254	558
169 480 255	558
169 480 256	558
169 480 281	539

Code	Page
169 480 282	541
169 480 283	541
169 480 301	498
169 480 302	498
169 480 303	498
169 480 304	498
169 480 305	498
169 480 306	498
169 480 342	509
169 480 343	509
169 480 344	509
169 480 376	510
169 480 377	510
169 480 378	510
169 480 392	542
169 480 468	502
169 480 469	502
169 480 470	502
169 480 471	502
169 480 472	502
169 480 473	502
169 480 490	503
169 480 491	503
169 480 492	503
169 480 493	503
169 480 494	503
169 480 495	503
169 480 513	503
169 480 514	503
169 480 515	503
169 480 516	503
169 480 517	503
169 480 518	503
169 480 537	503
169 480 538	503
169 480 539	503
169 480 540	503
169 480 541	503
169 480 542	503
169 480 600	552
169 480 601	552
169 480 602	552
169 480 603	552
169 480 604	552
169 480 605	552
169 480 609	553
169 480 610	553
169 480 611	553
169 480 612	553
169 480 613	553
169 480 614	553
169 480 713	550
169 480 714	550
169 480 715	550
169 480 716	550
169 480 717	550
169 480 718	550
169 480 719	550
169 480 720	550
169 480 721	550
169 480 751	490
169 480 752	490
169 480 753	490
169 480 754	490
169 480 755	490
169 480 756	490
169 480 757	490
169 480 758	490

Code	Page
169 480 759	490
169 480 775	547
169 480 776	547
169 480 777	547
169 480 778	547
169 480 779	547
169 480 780	547
169 480 781	547
169 480 782	547
169 480 783	547
169 480 784	547
169 480 786	548
169 480 787	548
169 480 788	548
169 480 789	548
169 480 790	548
169 480 791	548
169 480 792	548
169 480 800	547
169 480 801	547
169 480 802	547
169 480 803	547
169 480 804	547
169 480 805	547
169 480 806	547
169 480 808	547
169 480 809	547
169 480 826	522
169 480 827	522
169 480 829	522
169 480 900	491
169 480 901	491
169 480 902	491
169 480 903	491
169 480 904	491
169 480 905	491
169 480 906	491
169 480 907	491
169 480 908	491
169 480 925	548
169 480 926	548
169 480 927	548
169 480 928	548
169 480 929	548
169 480 930	548
169 480 931	548
169 480 951	518
169 480 952	518
169 480 953	518
169 480 954	518
169 480 955	518
169 480 956	518
169 480 957	518
169 481 067	517
169 481 068	517
169 481 069	517
169 481 070	517
169 481 071	517
169 481 072	517
169 481 073	517
169 481 202	493
169 481 203	493
169 481 204	493
169 481 205	493
169 481 206	493
169 481 207	493
169 481 212	493
169 481 213	493

Index

Code	Page
169 481 214	493
169 481 215	493
169 481 216	493
169 481 217	493
169 481 221	496
169 481 222	496
169 481 223	496
169 481 224	496
169 481 225	496
169 481 226	496
169 481 227	496
169 481 231	496
169 481 232	496
169 481 233	496
169 481 234	496
169 481 235	496
169 481 236	496
169 481 237	496
169 481 282	494
169 481 283	494
169 481 284	494
169 481 285	494
169 481 286	494
169 481 287	494
169 481 292	494
169 481 293	494
169 481 294	494
169 481 295	494
169 481 296	494
169 481 297	494
169 481 302	497
169 481 303	497
169 481 304	497
169 481 305	497
169 481 306	497
169 481 307	497
169 481 312	497
169 481 313	497
169 481 314	497
169 481 315	497
169 481 316	497
169 481 317	497
169 481 862	532
169 481 863	532
169 481 864	532
169 481 865	532
169 481 866	532
169 481 867	532
169 482 151	556
169 482 152	556
169 482 153	556
169 482 154	556
169 482 155	556
169 482 156	556
169 482 157	556
169 482 158	556
169 482 159	556
169 485 201	555
169 485 202	555
169 485 203	555
169 485 204	555
169 485 205	555
169 485 206	555
169 485 207	555
169 485 208	555
169 485 209	555
169 485 221	555
169 485 222	555

Code	Page
169 485 223	555
169 485 224	555
169 485 225	555
169 485 226	555
169 485 227	556
169 485 228	556
169 485 229	556
169 485 261	562
169 485 262	562
169 485 263	562
169 485 264	562
169 485 265	562
169 485 266	562
169 485 267	562
169 485 268	562
169 485 269	562
169 485 281	562
169 485 282	562
169 485 283	562
169 485 284	562
169 485 285	562
169 485 286	562
169 485 287	562
169 485 288	562
169 485 289	562
173 061 003	488
173 061 004	488
173 061 005	488
173 061 006	488
173 061 007	488
173 061 008	488
173 061 009	488
173 061 010	488
173 061 011	488
173 061 012	488
173 061 013	488
173 061 014	488
173 061 015	488
173 061 016	488
173 061 017	488
173 061 153	488
173 061 155	488
173 061 156	488
173 061 157	488
173 061 158	488
173 061 159	488
173 061 160	488
173 061 161	488
173 061 162	488
173 061 163	488
173 061 164	488
173 061 165	488
173 061 166	488
173 061 167	488
173 281 925	421
173 480 000	500
173 480 001	500
173 480 002	500
173 480 003	500
173 480 004	500
173 480 005	500
173 480 006	500
175 367 635	521
175 367 636	521
175 367 637	521
175 367 638	521
175 367 639	521
175 367 640	521

Code	Page
175 369 142	566
175 369 143	566
175 369 144	566
175 369 145	566
175 369 146	566
175 369 147	566
175 369 148	566
175 369 149	566
175 369 150	566
175 369 151	566
175 369 152	566
175 480 031	500
175 480 032	500
175 480 033	500
175 480 034	500
175 480 035	500
175 480 036	500
175 480 037	500
175 480 069	539
175 480 070	539
175 480 071	539
175 480 072	539
175 480 073	539
175 480 074	539
175 480 109	522
175 480 110	522
175 480 111	522
175 480 112	522
175 480 113	522
175 480 114	523
175 480 153	558
175 480 154	558
175 480 155	558
175 480 156	558
175 480 157	558
175 480 158	558
175 480 189	542
175 480 190	542
175 480 727	501
175 480 728	501
175 480 729	501
175 480 730	501
175 480 731	501
175 480 732	501
175 480 733	501
175 480 737	542
175 480 738	542
175 480 748	542
175 480 787	501
175 480 788	501
175 480 789	501
175 480 790	501
175 480 791	501
175 480 792	501
175 480 793	501
175 480 796	560
175 480 797	501
175 480 798	501
175 480 799	501
175 480 800	501
175 480 801	501
175 480 802	501
175 480 805	523
175 480 819	500
175 480 820	500
175 480 821	500
175 480 822	500
175 480 823	500

Index

Code	Page
175 480 824	500
175 480 825	499
175 480 826	499
175 480 827	499
175 480 828	499
175 480 829	499
175 480 830	499
175 480 831	499
175 480 900	499
175 480 901	499
175 480 902	499
175 480 903	499
175 480 904	499
175 480 905	499
175 480 910	522
175 480 911	522
175 480 912	522
175 480 913	522
175 480 914	522
175 480 915	522
175 481 002	542
175 481 840	539
175 481 841	539
175 481 842	539
175 481 843	539
175 481 844	539
175 481 845	539
175 481 850	539
175 481 851	539
175 481 852	539
175 481 853	539
175 481 854	539
175 481 855	539
175 481 860	543
175 481 861	543
175 481 862	543
175 481 863	543
175 481 943	542
175 481 944	542
175 481 945	542
175 481 946	542
175 481 947	542
175 481 948	542
175 481 949	542
175 481 977	536
175 481 978	536
175 481 979	536
175 481 980	536
175 481 981	536
175 481 982	536
175 482 593	502
175 482 594	502
175 482 595	502
175 482 596	502
175 482 597	502
175 482 598	502
175 482 620	503
175 482 621	503
175 482 622	503
175 482 623	503
175 482 624	503
175 482 625	503
175 482 662	503
175 482 663	503
175 482 664	503
175 482 665	503
175 482 666	503
175 482 667	503

Code	Page
175 482 687	504
175 482 688	504
175 482 689	504
175 482 690	504
175 482 691	504
175 482 692	504
175 482 937	550
175 482 938	550
175 482 939	550
175 482 940	550
175 482 941	550
175 482 942	550
175 482 943	550
175 482 944	550
175 482 945	550
175 482 963	490
175 482 964	490
175 482 965	490
175 482 966	490
175 482 967	490
175 482 968	490
175 482 969	490
175 482 970	490
175 482 971	490
175 482 975	542
175 482 976	542
175 482 977	542
175 482 978	542
175 482 979	542
175 482 980	542
175 482 981	542
175 483 013	305
175 483 025	548
175 483 026	548
175 483 027	548
175 483 028	548
175 483 029	548
175 483 030	548
175 483 031	548
175 483 036	548
175 483 037	548
175 483 038	548
175 483 039	548
175 483 040	548
175 483 041	548
175 483 042	548
175 483 048	549
175 483 049	549
175 483 050	549
175 483 051	549
175 483 052	549
175 483 053	549
175 483 058	548
175 483 059	548
175 483 060	548
175 483 061	548
175 483 062	548
175 483 063	548
175 483 064	548
175 483 069	523
175 483 070	523
175 483 071	523
175 483 072	523
175 483 073	523
175 483 074	523
175 483 251	518
175 483 252	518
175 483 253	518

Code	Page
175 483 254	518
175 483 255	518
175 483 256	518
175 483 257	518
175 483 258	518
175 483 259	518
175 483 275	491
175 483 276	491
175 483 277	491
175 483 278	491
175 483 279	491
175 483 280	491
175 483 281	491
175 483 282	491
175 483 283	491
175 483 285	549
175 483 286	549
175 483 287	549
175 483 288	549
175 483 289	549
175 483 290	549
175 483 413	517
175 483 414	517
175 483 415	517
175 483 416	517
175 483 417	517
175 483 418	517
175 483 419	517
175 483 420	517
175 483 421	517
175 483 426	519
175 483 427	519
175 483 428	519
175 483 429	519
175 483 532	532
175 483 533	532
175 483 534	532
175 483 535	532
175 483 536	532
175 483 537	532
175 483 602	493
175 483 603	493
175 483 604	493
175 483 605	493
175 483 606	493
175 483 607	493
175 483 612	493
175 483 613	493
175 483 614	493
175 483 615	493
175 483 616	493
175 483 617	493
175 483 642	494
175 483 643	494
175 483 644	494
175 483 645	494
175 483 646	494
175 483 647	494
175 483 652	494
175 483 653	494
175 483 654	494
175 483 655	494
175 483 656	494
175 483 657	494
175 483 682	531
175 483 683	531
175 483 684	531
175 483 685	531

Index

Code	Page	Code	Page	Code	Page
175 483 686	531	175 485 291	563	193 017 113	389
175 483 687	531	175 485 292	563	193 017 114	389
175 483 692	532	175 485 293	563	193 017 115	389
175 483 693	532	175 485 294	563	193 017 116	389
175 483 694	532	175 485 295	563	193 017 117	389
175 483 695	532	175 485 296	563	193 017 118	389
175 483 696	532	175 485 297	563	193 017 119	389
175 483 697	532	175 485 298	563	193 017 120	389
175 483 742	532	175 485 299	563	193 017 121	389
175 483 743	532	180 001 002	531	193 017 122	389
175 483 744	532	180 001 003	531	193 017 123	389
175 483 745	532	180 001 004	531	193 017 124	389
175 483 746	532	180 001 005	531	193 017 125	389
175 483 747	532	180 001 006	531	193 017 126	389
175 483 752	517	180 001 007	531	193 017 127	389
175 483 753	517	180 001 012	532	193 017 156	388
175 483 754	517	180 001 013	532	193 017 157	388
175 483 755	517	180 001 014	532	193 017 158	388
175 483 756	517	180 001 015	532	193 017 159	388
175 483 757	517	180 001 016	532	193 017 160	388
175 483 758	517	180 001 017	532	193 017 161	388
175 483 759	517	180 001 101	533	193 017 162	388
175 483 760	517	180 001 102	533	193 017 163	388
175 484 151	556	180 001 103	533	193 017 164	388
175 484 152	556	180 001 104	533	193 017 165	388
175 484 153	556	180 001 105	533	193 017 166	388
175 484 154	556	180 001 106	533	193 017 167	388
175 484 155	556	180 001 107	533	193 017 168	388
175 484 156	556	180 001 108	533	193 017 169	388
175 484 157	556	180 001 109	533	193 017 170	388
175 484 158	556	180 001 110	534	193 017 171	388
175 484 159	556	180 001 111	534	193 017 172	388
175 484 161	563	180 001 112	534	193 017 173	388
175 484 162	563	180 001 113	534	193 017 174	388
175 484 163	563	180 001 114	534	193 017 175	388
175 484 164	563	180 001 115	534	193 017 206	388
175 484 165	563	180 001 116	534	193 017 207	388
175 484 166	563	180 001 117	534	193 131 037	452
175 484 167	563	180 001 118	534	193 131 047	452
175 484 168	563	180 001 119	534	193 131 057	452
175 484 169	563	180 001 120	534	193 131 067	452
175 485 211	555	180 001 121	534	193 131 077	452
175 485 212	555	180 001 126	534	193 131 087	452
175 485 213	555	180 001 127	534	193 131 097	452
175 485 214	555	180 001 128	534	193 131 107	452
175 485 215	555	180 001 129	534	193 131 117	452
175 485 216	555	180 001 130	534	193 131 127	452
175 485 217	555	180 001 131	534	193 131 137	452
175 485 218	555	180 001 132	534	193 131 147	452
175 485 219	555	180 001 133	534	193 131 157	452
175 485 231	556	180 001 134	534	193 131 234	454
175 485 232	556	192 300 301	552	193 131 237	454
175 485 233	556	192 300 351	552	193 131 244	454
175 485 234	556	192 300 401	552	193 131 247	454
175 485 235	556	192 300 451	552	193 131 254	454
175 485 236	556	192 300 501	552	193 131 257	454
175 485 237	556	192 300 551	552	193 131 264	454
175 485 238	556	192 300 601	552	193 131 267	454
175 485 239	556	192 300 651	552	193 131 274	454
175 485 271	562	192 301 401	552	193 131 277	454
175 485 272	562	192 301 451	552	193 131 284	454
175 485 273	562	192 301 501	552	193 131 287	454
175 485 274	562	192 301 551	552	193 131 294	454
175 485 275	562	192 480 001	552	193 131 297	454
175 485 276	562	192 480 002	552	193 131 304	454
175 485 277	562	193 017 110	389	193 131 307	454
175 485 278	562	193 017 111	389	193 131 314	454
175 485 279	562	193 017 112	389	193 131 317	454

Index

Code	Page
193 131 324	454
193 131 327	454
193 131 334	454
193 131 337	454
193 131 347	454
193 131 357	454
193 131 402	453
193 131 403	453
193 131 404	453
193 131 405	453
193 131 412	452
193 131 413	452
193 131 414	452
193 131 422	452
193 131 423	452
193 131 424	452
193 131 432	452
193 131 433	452
193 131 434	452
193 131 437	453
193 131 442	453
193 131 443	453
193 131 444	453
193 131 445	453
193 131 447	453
193 131 452	453
193 131 453	453
193 131 454	453
193 131 455	453
193 131 457	453
193 131 462	453
193 131 463	453
193 131 464	453
193 131 465	453
193 131 467	453
193 131 472	453
193 131 473	453
193 131 474	453
193 131 475	453
193 131 477	453
193 131 482	453
193 131 483	453
193 131 484	453
193 131 485	453
193 131 487	453
193 131 492	453
193 131 493	453
193 131 494	453
193 131 495	453
193 131 497	453
193 131 502	453
193 131 503	453
193 131 504	453
193 131 505	453
193 131 507	453
193 131 512	453
193 131 513	453
193 131 514	453
193 131 515	453
193 131 517	453
193 131 522	453
193 131 523	453
193 131 524	453
193 131 525	453
193 131 527	454
193 131 532	454
193 131 533	454
193 131 534	454

Code	Page
193 131 535	454
193 131 537	454
193 131 547	454
193 131 557	454
193 135 009	450
193 135 010	450
193 135 019	450
193 135 020	450
193 135 029	450
193 135 030	450
193 135 039	450
193 135 040	450
193 135 041	450
193 135 049	451
193 135 050	451
193 135 051	451
193 135 059	451
193 135 060	451
193 135 061	451
193 135 069	451
193 135 070	451
193 135 071	451
193 135 079	451
193 135 080	451
193 135 081	451
193 135 159	451
193 135 160	451
193 135 161	451
193 135 289	451
193 135 290	451
193 135 291	451
193 135 309	451
193 135 310	451
193 135 311	451
193 135 329	451
193 135 330	451
193 135 331	451
193 135 402	451
193 135 404	451
193 135 412	451
193 135 414	451
193 135 422	451
193 135 424	451
193 135 432	451
193 135 434	451
193 135 442	451
193 135 444	451
193 135 452	451
193 135 454	452
193 135 462	452
193 135 464	452
193 135 472	452
193 135 474	452
193 135 482	452
193 135 484	452
193 135 494	452
193 135 504	452
193 280 950	449
193 280 951	449
193 280 952	449
193 280 953	449
193 280 954	449
193 280 958	449
193 280 959	449
193 280 961	447
193 280 963	447
193 280 965	447
193 280 992	449

Code	Page
193 280 993	449
193 280 994	449
193 280 995	449
193 280 996	449
193 280 997	447
193 280 998	447
193 280 999	447
193 281 004	447
193 281 005	447
193 281 006	447
193 281 007	447
193 281 008	447
193 281 009	447
193 281 010	447
193 281 011	447
193 281 012	447
193 281 013	448
193 281 030	448
193 281 031	448
193 281 032	447
193 281 033	447
193 281 617	421
193 480 014	560
193 480 015	560
193 480 016	560
193 480 017	501
193 480 018	501
193 480 026	560
193 480 027	501
193 480 028	501
193 480 029	501
193 480 030	501
193 480 031	501
193 480 032	501
193 480 087	549
193 480 088	549
193 480 102	549
193 480 103	549
193 480 104	549
193 480 105	549
193 480 106	549
193 480 107	549
193 480 127	501
193 480 128	501
193 480 129	501
193 480 130	501
193 480 131	501
193 480 132	501
193 480 152	549
193 480 153	549
193 480 154	549
193 480 155	549
193 480 156	549
193 480 157	549
193 480 158	549
193 480 159	549
193 480 160	549
193 480 168	549
193 480 169	549
193 480 170	549
193 480 176	548
193 480 177	548
193 480 178	548
193 480 179	548
193 480 180	548
193 480 181	548
198 000 268	589
198 000 269	589

Index

Code	Page
198 000 270	589
198 000 271	589
198 000 272	589
198 000 273	589
198 000 274	589
198 000 275	589
198 000 320	589
198 000 321	589
198 000 322	589
198 000 323	589
198 000 324	589
198 000 325	589
198 000 326	589
198 000 327	589
198 000 328	589
198 000 329	589
198 000 330	589
198 000 331	589
198 000 332	590
198 000 333	590
198 000 334	590
198 000 335	590
198 000 336	590
198 000 595	524
198 000 596	524
198 000 597	525
198 000 598	525
198 000 599	525
198 000 600	524
198 000 601	525
198 000 602	525
198 000 603	525
198 000 621	525
198 000 622	525
198 000 623	525
198 000 624	525
198 000 625	525
198 000 627	525
198 000 628	525
198 000 629	525
198 000 630	525
198 000 631	525
198 000 650	536
198 000 651	536
198 000 652	536
198 000 653	536
198 000 654	536
198 000 655	536
198 000 730	525
198 000 731	525
198 000 732	525
198 000 872	530
198 000 873	530
198 000 874	530
198 000 875	530
198 000 876	530
198 000 877	530
198 000 880	526
198 000 881	530
198 000 882	530
198 000 883	530
198 000 884	530
198 000 885	530
198 000 886	530
198 000 892	528
198 000 893	528
198 000 894	528
198 000 895	528

Code	Page
198 000 896	528
198 000 897	528
198 104 166	527
198 150 087	590
198 150 088	590
198 150 089	590
198 150 090	590
198 150 091	590
198 150 093	590
198 150 094	590
198 150 095	590
198 150 097	590
198 150 098	590
198 150 099	590
198 150 100	591
198 150 101	591
198 150 102	591
198 150 103	591
198 150 104	591
198 150 105	590
198 150 106	590
198 150 107	590
198 150 108	590
198 150 109	590
198 150 124	590
198 150 125	590
198 150 126	590
198 150 127	579
198 150 128	579
198 150 129	579
198 150 130	579
198 150 131	579
198 150 132	579
198 150 144	579
198 150 145	579
198 150 146	579
198 150 147	579
198 150 148	579
198 150 149	579
198 150 180	585
198 150 181	585
198 150 182	585
198 150 183	585
198 150 184	585
198 150 185	585
198 150 186	585
198 150 187	585
198 150 736	590
198 150 737	590
198 150 738	590
198 150 739	590
198 150 746	590
198 150 747	590
198 150 748	590
198 150 749	590
198 150 756	591
198 150 757	591
198 150 758	591
198 150 759	591
198 150 962	590
198 150 963	590
198 150 964	590
198 150 965	590
198 150 966	590
198 150 967	590
198 150 969	590
198 150 975	591
198 151 120	591

Code	Page
198 151 121	591
198 151 122	591
198 151 123	591
198 151 124	591
198 151 125	591
198 151 126	591
198 151 127	591
198 151 128	591
198 151 129	591
198 151 130	591
198 151 131	591
198 151 136	591
198 151 137	591
198 151 138	591
198 151 139	591
198 151 140	591
198 151 141	591
198 151 142	591
198 151 143	591
198 151 145	591
198 151 146	591
198 151 147	591
198 151 148	591
198 151 149	591
198 151 150	591
198 151 151	591
198 151 152	591
198 151 154	591
198 151 155	591
198 151 156	591
198 151 157	591
198 151 158	591
198 151 159	591
198 151 161	591
198 151 162	591
198 151 163	591
198 151 164	591
198 151 165	591
198 151 166	591
198 151 168	591
198 151 169	591
198 151 317	586
198 151 335	127
198 151 336	127
198 151 337	127
198 151 338	127
198 151 339	127
198 151 340	127
198 151 341	602
198 151 342	602
198 151 343	602
198 151 344	602
198 151 426	586
198 151 742	527
198 151 743	527
198 151 744	527
198 151 745	527
198 151 746	527
198 151 747	527
198 151 752	527
198 151 753	527
198 151 754	527
198 151 755	527
198 151 756	527
198 151 757	527
198 151 762	529
198 151 763	529
198 151 764	529

Index

Code	Page
198 151 765	529
198 151 766	529
198 151 767	529
198 151 772	529
198 151 773	529
198 151 774	529
198 151 775	529
198 151 776	529
198 151 777	529
198 151 782	529
198 151 783	529
198 151 784	529
198 151 785	529
198 151 786	529
198 151 787	529
198 151 792	529
198 151 793	529
198 151 794	529
198 151 795	529
198 151 796	529
198 151 797	529
198 151 802	529
198 151 803	529
198 151 804	529
198 151 805	529
198 151 806	529
198 151 807	529
198 151 842	527
198 151 843	527
198 151 844	527
198 151 845	527
198 151 846	527
198 151 847	527
198 151 852	527
198 151 853	527
198 151 854	527
198 151 855	527
198 151 856	527
198 151 857	527
198 153 062	529
198 153 063	529
198 153 064	529
198 153 065	529
198 153 066	529
198 153 067	529
198 204 162	527
198 204 164	527
198 204 327	528
198 204 328	528
198 204 329	528
198 335 000	298
198 335 001	298
198 335 002	298
198 335 003	298
198 335 004	298
198 335 005	298
198 335 006	298
198 335 007	298
198 335 008	298
198 335 009	298
198 335 010	298
198 335 011	298
198 335 012	298
198 335 020	298
198 335 021	298
198 335 022	298
198 335 023	298
198 335 024	298

Code	Page
198 335 025	298
198 335 026	298
198 335 027	298
198 335 028	298
198 335 029	298
198 335 030	298
198 335 031	298
198 335 032	298
198 335 033	306
198 335 034	306
198 335 035	306
198 335 036	306
198 335 037	306
198 335 038	306
198 335 039	306
198 335 040	298
198 335 041	298
198 335 042	298
198 335 043	298
198 335 044	298
198 335 045	298
198 335 046	298
198 335 047	298
198 335 048	298
198 335 049	298
198 335 050	298
198 335 051	298
198 335 052	298
198 335 053	306
198 335 054	306
198 335 055	570
198 335 056	570
198 335 057	570
198 335 058	570
198 335 059	570
198 335 060	570
198 335 061	570
198 335 062	570
198 335 063	570
198 335 064	570
198 335 065	570
198 335 066	570
198 335 067	570
198 335 068	306
198 335 069	306
198 335 070	570
198 335 071	570
198 335 072	570
198 335 073	570
198 335 074	570
198 335 075	570
198 335 076	570
198 335 077	570
198 335 078	570
198 335 079	570
198 335 080	570
198 335 081	570
198 335 082	570
198 335 083	306
198 335 084	306
198 335 085	570
198 335 086	570
198 335 087	570
198 335 088	570
198 335 089	570
198 335 090	570
198 335 091	570
198 335 092	570

Code	Page
198 335 093	570
198 335 094	570
198 335 095	570
198 335 096	570
198 335 097	570
198 335 098	572
198 335 100	299
198 335 101	299
198 335 102	299
198 335 103	299
198 335 104	299
198 335 105	299
198 335 106	299
198 335 107	299
198 335 108	299
198 335 109	299
198 335 110	299
198 335 111	299
198 335 112	299
198 335 120	299
198 335 121	299
198 335 122	299
198 335 123	299
198 335 124	299
198 335 125	299
198 335 126	299
198 335 127	299
198 335 128	299
198 335 129	299
198 335 130	299
198 335 131	299
198 335 132	299
198 335 140	299
198 335 141	299
198 335 142	299
198 335 143	299
198 335 144	299
198 335 145	299
198 335 146	299
198 335 147	299
198 335 148	299
198 335 149	299
198 335 150	299
198 335 151	299
198 335 152	299
198 335 255	570
198 335 256	570
198 335 257	570
198 335 258	570
198 335 259	570
198 335 260	570
198 335 261	570
198 335 262	570
198 335 263	570
198 335 264	570
198 335 265	570
198 335 266	570
198 335 267	570
198 335 270	570
198 335 271	570
198 335 272	570
198 335 273	570
198 335 274	570
198 335 275	570
198 335 276	570
198 335 277	570
198 335 278	570
198 335 279	570

Index

Code	Page
198 335 280	570
198 335 281	570
198 335 282	570
198 335 285	570
198 335 286	570
198 335 287	570
198 335 288	570
198 335 289	570
198 335 290	570
198 335 291	570
198 335 292	570
198 335 293	570
198 335 294	570
198 335 295	570
198 335 296	570
198 335 297	570
198 335 455	571
198 335 456	571
198 335 457	571
198 335 458	571
198 335 459	571
198 335 460	571
198 335 470	571
198 335 471	571
198 335 472	571
198 335 473	571
198 335 474	571
198 335 655	306
198 335 656	306
198 335 657	306
198 335 658	307
198 335 659	307
198 335 660	307
198 335 661	307
198 335 662	307
198 335 663	307
198 335 664	307
198 335 665	307
198 335 666	307
198 335 667	307
198 335 670	307
198 335 671	307
198 335 672	307
198 335 673	307
198 335 674	307
198 335 675	307
198 335 676	307
198 335 677	307
198 335 678	307
198 335 679	307
198 335 680	307
198 335 681	307
198 335 682	307
198 335 685	307
198 335 686	307
198 335 687	307
198 335 688	307
198 335 689	307
198 335 690	307
198 335 691	307
198 335 692	307
198 335 693	307
198 335 694	307
198 335 695	307
198 335 696	307
198 335 697	307
198 335 861	306
198 335 862	306

Code	Page
198 335 863	306
198 335 864	306
198 335 865	306
198 335 866	306
198 335 867	306
198 335 868	306
198 335 869	306
198 335 870	306
198 335 871	306
198 335 872	306
198 335 873	306
198 335 893	571
198 335 894	571
198 335 895	573
198 335 896	573
198 335 953	572
198 335 954	572
198 335 960	306
198 335 961	306
198 335 962	305
198 335 963	305
198 335 964	305
198 335 965	305
198 335 966	305
198 335 967	305
198 335 968	305
198 335 969	305
198 335 970	571
198 335 971	571
198 335 972	571
198 335 973	571
198 335 974	571
198 335 975	571
198 335 977	571
198 335 978	571
198 335 979	571
198 335 980	571
198 335 981	571
198 335 982	571
198 335 984	572
198 335 985	572
198 335 986	572
198 335 987	572
198 335 990	572
198 335 991	305
198 335 992	305
198 335 993	305
198 335 994	305
198 335 995	305
198 350 000	300
198 350 001	300
198 350 002	300
198 350 003	300
198 350 004	300
198 350 005	300
198 350 006	300
198 350 007	300
198 350 008	300
198 350 009	300
198 350 010	300
198 350 011	300
198 350 012	300
198 350 020	300
198 350 021	300
198 350 022	300
198 350 023	300
198 350 024	300
198 350 025	300

Code	Page
198 350 026	300
198 350 027	300
198 350 028	300
198 350 029	300
198 350 030	300
198 350 031	300
198 350 032	300
198 350 040	300
198 350 041	300
198 350 042	300
198 350 043	300
198 350 044	300
198 350 045	300
198 350 046	300
198 350 047	300
198 350 048	300
198 350 049	300
198 350 050	300
198 350 051	300
198 350 052	300
198 350 055	574
198 350 056	574
198 350 057	574
198 350 058	574
198 350 059	574
198 350 060	574
198 350 061	574
198 350 062	574
198 350 063	574
198 350 064	574
198 350 065	574
198 350 066	574
198 350 067	574
198 350 070	574
198 350 071	574
198 350 072	574
198 350 073	574
198 350 074	574
198 350 075	574
198 350 076	574
198 350 077	574
198 350 078	574
198 350 079	574
198 350 080	574
198 350 081	574
198 350 082	574
198 350 085	574
198 350 086	574
198 350 087	574
198 350 088	574
198 350 089	574
198 350 090	574
198 350 091	574
198 350 092	574
198 350 093	574
198 350 094	574
198 350 095	574
198 350 096	574
198 350 097	574
198 350 098	575
198 350 100	301
198 350 101	301
198 350 102	301
198 350 103	301
198 350 104	301
198 350 105	301
198 350 106	301
198 350 107	301

Index

Code	Page
198 350 108	301
198 350 109	301
198 350 110	301
198 350 111	301
198 350 112	301
198 350 120	301
198 350 121	301
198 350 122	301
198 350 123	301
198 350 124	301
198 350 125	301
198 350 126	301
198 350 127	301
198 350 128	301
198 350 129	301
198 350 130	301
198 350 131	301
198 350 132	301
198 350 140	301
198 350 141	301
198 350 142	301
198 350 143	301
198 350 144	301
198 350 145	301
198 350 146	301
198 350 147	301
198 350 148	301
198 350 149	301
198 350 150	301
198 350 151	301
198 350 152	301
198 350 255	574
198 350 256	574
198 350 257	574
198 350 258	574
198 350 259	574
198 350 260	574
198 350 261	574
198 350 262	574
198 350 263	574
198 350 264	574
198 350 265	574
198 350 266	574
198 350 267	574
198 350 270	574
198 350 271	574
198 350 272	574
198 350 273	574
198 350 274	574
198 350 275	574
198 350 276	574
198 350 277	574
198 350 278	574
198 350 279	574
198 350 280	574
198 350 281	574
198 350 282	574
198 350 285	574
198 350 286	574
198 350 287	574
198 350 288	574
198 350 289	574
198 350 290	574
198 350 291	574
198 350 292	574
198 350 293	574
198 350 294	574
198 350 295	574

Code	Page
198 350 296	574
198 350 297	574
198 350 655	307
198 350 656	307
198 350 657	307
198 350 658	307
198 350 659	307
198 350 660	307
198 350 661	308
198 350 662	308
198 350 663	308
198 350 664	308
198 350 665	308
198 350 666	308
198 350 667	308
198 350 670	308
198 350 671	308
198 350 672	308
198 350 673	308
198 350 674	308
198 350 675	308
198 350 676	308
198 350 677	308
198 350 678	308
198 350 679	308
198 350 680	308
198 350 681	308
198 350 682	308
198 350 685	308
198 350 686	308
198 350 687	308
198 350 688	308
198 350 689	308
198 350 690	308
198 350 691	308
198 350 692	308
198 350 693	308
198 350 694	308
198 350 695	308
198 350 696	308
198 350 697	308
198 350 755	308
198 350 756	308
198 350 757	308
198 350 758	308
198 350 759	308
198 350 760	308
198 350 761	308
198 350 762	308
198 350 763	308
198 350 764	308
198 350 765	309
198 350 766	309
198 350 767	309
198 350 895	577
198 350 896	577
198 350 980	575
198 350 981	575
198 800 004	580
198 800 005	580
198 800 006	580
198 800 007	580
198 800 017	580
198 800 018	580
198 800 019	580
198 800 020	580
198 800 025	580
198 800 026	580

Code	Page
198 800 028	580
198 800 029	580
198 800 034	580
198 800 037	580
198 800 039	580
198 800 040	581
198 800 041	580
198 800 042	581
198 800 043	580
198 800 044	581
198 800 045	580
198 800 046	581
198 800 047	580
198 800 048	581
198 800 050	581
198 800 051	581
198 800 052	580
198 800 054	580
198 800 056	580
198 800 058	580
198 800 060	580
198 800 062	580
198 800 728	580
198 800 729	580
198 800 730	580
198 800 731	580
198 800 733	581
198 800 734	581
198 800 735	581
198 800 737	581
198 800 757	580
198 800 758	581
198 800 759	581
198 801 308	309
198 801 309	309
198 801 310	309
198 801 311	309
198 801 312	309
198 801 313	309
198 801 314	309
198 801 315	309
198 801 316	309
198 801 317	309
198 801 338	577
198 801 339	577
198 801 340	577
198 801 341	577
198 801 342	577
198 801 343	577
198 801 386	309
198 801 387	309
198 801 388	309
198 801 389	309
198 801 390	309
198 801 391	309
198 801 392	309
198 801 393	309
198 801 394	309
198 801 395	309
198 801 445	577
198 801 449	577
198 801 450	577
198 801 451	577
198 801 880	302
198 801 881	302
198 801 882	302
198 801 883	302
198 801 884	302

Index

Code	Page
198 801 885	302
198 801 886	302
198 801 887	302
198 801 888	302
198 801 889	302
198 801 890	302
198 801 891	302
198 801 892	302
198 801 893	302
198 801 894	302
198 801 895	302
198 801 896	302
198 801 897	302
198 801 898	302
198 801 899	302
198 801 961	309
198 801 962	309
198 801 963	309
198 801 964	309
198 801 965	309
198 801 966	309
198 801 967	309
198 801 968	309
198 801 969	309
198 801 970	309
198 803 310	302
198 803 311	302
198 803 312	302
198 803 313	302
198 803 314	302
198 803 315	302
198 803 316	302
198 803 317	302
198 803 318	302
198 803 319	302
198 803 320	302
198 803 321	302
198 803 322	302
198 803 323	302
198 803 324	302
198 803 325	302
198 803 326	302
198 803 327	302
198 803 328	302
198 803 329	302
198 803 790	577
198 803 791	577
198 803 792	577
198 803 793	577
198 803 794	577
198 803 795	577
198 803 796	577
198 803 797	577
198 803 798	577
198 803 799	577
198 803 905	304
198 803 906	304
198 803 907	304
198 803 908	304
198 803 909	304
198 803 910	304
198 803 911	304
198 803 912	304
198 804 875	593
198 806 219	578
198 806 220	578
198 806 221	578
198 806 222	578

Code	Page
198 806 223	578
198 806 224	578
198 806 376	589
198 806 421	304
198 806 422	304
198 806 429	304
198 806 466	304
198 806 467	304
198 806 468	304
198 806 469	304
198 806 470	304
198 806 471	304
198 806 511	309
198 806 512	309
198 806 513	309
198 806 514	309
198 806 515	309
198 806 516	310
198 806 517	310
198 806 518	310
198 806 519	310
198 806 520	310
198 806 521	310
198 806 522	310
198 806 523	310
198 806 524	310
198 806 525	310
198 806 526	310
198 806 527	310
198 806 528	310
198 806 529	310
198 806 530	310
198 806 531	310
198 806 532	310
198 806 533	310
198 806 534	310
198 806 535	310
198 806 536	310
198 806 537	310
198 806 639	529
198 806 640	529
198 807 166	578
198 807 167	310
198 807 168	310
198 807 169	310
198 807 170	310
198 807 171	310
198 807 172	310
198 807 182	578
198 807 187	578
198 807 188	578
198 807 202	303
198 807 203	303
198 807 204	303
198 807 205	303
198 807 206	303
198 807 207	303
198 807 208	303
198 807 209	303
198 807 210	303
198 808 000	568
198 808 001	568
198 808 002	568
198 808 003	568
198 808 004	568
198 808 005	568
198 808 006	568
198 808 007	568

Code	Page
198 808 008	568
198 808 009	568
198 808 010	568
198 808 011	568
198 808 012	568
198 808 013	568
198 808 014	568
198 808 015	568
198 808 016	568
198 808 017	568
198 808 018	568
198 808 019	568
198 808 020	568
198 808 021	568
198 808 022	568
198 808 023	568
198 808 024	568
198 808 025	568
198 808 026	568
198 808 027	568
198 808 028	568
198 808 029	568
198 808 030	568
198 808 031	568
198 808 032	568
198 808 033	568
198 808 034	568
198 808 035	568
198 808 036	568
198 808 037	568
198 808 038	568
198 808 039	568
198 808 040	568
198 808 041	569
198 808 042	569
198 808 043	569
198 808 044	569
198 808 045	569
198 808 046	569
198 808 047	569
198 808 048	569
198 808 049	569
198 808 050	569
198 808 051	569
198 808 052	569
198 808 053	569
198 808 054	569
198 811 025	580
198 811 026	580
198 811 027	580
198 811 028	580
198 811 029	580
198 811 030	580
198 811 190	580
198 811 194	580
198 811 198	580
199 025 267	253
199 025 268	253
199 025 269	253
199 025 270	253
199 025 277	261
199 025 278	261
199 025 279	261
199 025 280	261
199 025 287	268
199 025 288	268
199 025 289	268
199 025 290	268

Index

Code	Page
199 025 297	253
199 025 298	253
199 025 299	253
199 025 307	261
199 025 308	261
199 025 309	261
199 025 310	261
199 025 317	268
199 025 318	268
199 025 319	268
199 025 320	268
199 041 002	314
199 041 003	314
199 041 008	314
199 041 009	314
199 041 039	311
199 041 040	311
199 041 041	311
199 041 049	311
199 041 050	311
199 041 051	311
199 041 072	312
199 041 073	312
199 041 074	312
199 041 075	312
199 041 076	312
199 041 077	312
199 041 078	312
199 041 079	312
199 041 080	312
199 041 081	312
199 041 082	312
199 041 083	312
199 041 102	313
199 041 103	313
199 041 104	313
199 041 105	313
199 041 106	313
199 041 107	313
199 041 108	313
199 041 109	313
199 041 110	313
199 041 111	313
199 041 112	313
199 041 113	313
199 041 129	314
199 041 130	314
199 041 131	314
199 041 132	314
199 041 133	314
199 041 134	314
199 041 135	315
199 041 136	315
199 041 137	315
199 041 165	315
199 041 166	315
199 041 167	315
199 041 168	315
199 041 169	315
199 041 170	315
199 041 171	315
199 041 172	315
199 041 173	315
199 041 174	315
199 041 175	315
199 041 176	315
199 041 177	315
199 041 178	315

Code	Page
199 041 179	315
199 041 180	315
199 041 181	315
199 041 182	315
199 041 217	315
199 041 218	315
199 041 219	315
199 041 220	315
199 041 221	315
199 041 222	315
199 041 223	315
199 041 224	315
199 041 225	315
199 041 226	315
199 041 227	315
199 041 228	315
199 041 229	315
199 041 230	315
199 041 294	314
199 041 295	314
199 041 299	312
199 041 300	312
199 041 301	312
199 041 302	312
199 041 303	312
199 041 351	311
199 041 358	311
199 041 377	311
199 041 378	311
199 041 404	312
199 041 405	312
199 041 406	312
199 041 407	312
199 041 408	312
199 041 417	311
199 041 418	311
199 041 419	311
199 041 427	311
199 041 428	311
199 041 429	311
199 041 431	313
199 041 432	313
199 041 433	313
199 041 434	313
199 041 435	313
199 041 437	313
199 041 438	313
199 041 439	313
199 041 440	313
199 041 441	313
199 041 621	311
199 041 622	311
199 041 623	311
199 041 624	311
199 041 625	311
199 041 626	311
199 041 631	311
199 041 632	311
199 041 633	311
199 041 634	311
199 041 635	311
199 041 636	311
199 041 641	311
199 041 642	311
199 041 643	311
199 041 644	311
199 041 645	311
199 041 646	311

Code	Page
199 041 651	311
199 041 652	311
199 041 653	311
199 041 654	311
199 041 655	311
199 041 656	311
199 107 502	156
199 107 503	156
199 107 504	156
199 107 505	156
199 107 506	156
199 107 507	156
199 107 508	156
199 107 512	156
199 107 513	156
199 107 514	156
199 107 515	156
199 107 516	156
199 107 517	156
199 107 518	156
199 107 522	157
199 107 523	157
199 107 524	157
199 107 525	157
199 107 526	157
199 107 527	157
199 107 528	157
199 107 532	157
199 107 533	157
199 107 534	157
199 107 535	157
199 107 536	157
199 107 537	157
199 107 538	157
199 107 542	160
199 107 543	160
199 107 544	160
199 107 545	160
199 107 546	160
199 107 547	160
199 107 548	160
199 107 552	160
199 107 553	160
199 107 554	160
199 107 555	160
199 107 556	160
199 107 557	160
199 107 558	160
199 107 562	161
199 107 563	161
199 107 564	161
199 107 565	161
199 107 566	161
199 107 567	161
199 107 568	161
199 107 572	161
199 107 573	161
199 107 574	161
199 107 575	161
199 107 576	161
199 107 577	161
199 107 578	161
199 107 583	159
199 107 584	159
199 107 585	159
199 107 586	159
199 107 587	159
199 107 588	159

Index

Code	Page
199 107 593	159
199 107 594	159
199 107 595	159
199 107 596	159
199 107 597	159
199 107 598	159
199 107 783	163
199 107 784	163
199 107 785	163
199 107 786	163
199 107 787	163
199 107 788	163
199 107 793	163
199 107 794	163
199 107 795	163
199 107 796	163
199 107 797	163
199 107 798	163
199 131 002	164
199 131 003	164
199 131 004	164
199 131 005	164
199 131 006	164
199 131 007	164
199 131 008	164
199 131 009	164
199 131 010	164
199 131 011	164
199 131 012	164
199 131 013	164
199 131 014	164
199 131 015	164
199 131 016	164
199 131 017	164
199 131 018	164
199 131 019	164
199 131 020	164
199 131 021	164
199 131 022	165
199 131 023	165
199 131 024	165
199 131 025	165
199 131 026	165
199 131 027	165
199 131 028	165
199 131 029	165
199 131 030	165
199 131 031	165
199 131 032	165
199 131 033	165
199 131 034	165
199 131 035	165
199 131 036	165
199 131 037	165
199 131 038	165
199 131 039	165
199 131 040	165
199 131 041	165
199 131 042	170
199 131 043	170
199 131 044	170
199 131 045	170
199 131 046	170
199 131 047	170
199 131 048	170
199 131 049	170
199 131 050	170
199 131 051	170

Code	Page
199 131 052	170
199 131 053	170
199 131 054	170
199 131 055	170
199 131 056	170
199 131 057	170
199 131 058	170
199 131 059	170
199 131 060	170
199 131 061	170
199 131 062	171
199 131 063	171
199 131 064	171
199 131 065	171
199 131 066	171
199 131 067	171
199 131 068	171
199 131 069	171
199 131 070	171
199 131 071	171
199 131 072	171
199 131 073	171
199 131 074	171
199 131 075	171
199 131 076	171
199 131 077	171
199 131 078	171
199 131 079	171
199 131 080	171
199 131 081	171
199 131 083	166
199 131 084	166
199 131 085	166
199 131 086	166
199 131 087	166
199 131 088	166
199 131 093	166
199 131 094	166
199 131 095	166
199 131 096	166
199 131 097	166
199 131 098	166
199 131 103	172
199 131 104	172
199 131 105	172
199 131 106	172
199 131 107	172
199 131 108	172
199 131 113	172
199 131 114	172
199 131 115	172
199 131 116	172
199 131 117	172
199 131 118	172
199 131 129	167
199 131 130	167
199 131 131	167
199 131 139	167
199 131 140	167
199 131 141	167
199 131 149	173
199 131 150	173
199 131 151	173
199 131 159	173
199 131 160	173
199 131 161	173
199 131 329	168
199 131 330	168

Code	Page
199 131 331	168
199 131 339	168
199 131 340	168
199 131 341	168
199 131 363	174
199 131 364	174
199 131 365	174
199 131 366	174
199 131 367	174
199 131 368	174
199 131 369	174
199 131 370	174
199 131 371	174
199 131 373	174
199 131 374	174
199 131 375	174
199 131 376	174
199 131 377	174
199 131 378	174
199 131 379	174
199 131 380	174
199 131 381	174
199 131 402	177
199 131 403	177
199 131 404	177
199 131 405	177
199 131 406	177
199 131 407	177
199 131 408	177
199 131 412	177
199 131 413	177
199 131 414	177
199 131 415	177
199 131 416	177
199 131 417	177
199 131 418	177
199 131 422	179
199 131 423	179
199 131 424	179
199 131 425	179
199 131 426	179
199 131 427	179
199 131 428	179
199 131 432	179
199 131 433	179
199 131 434	179
199 131 435	179
199 131 436	179
199 131 437	179
199 131 438	179
199 131 529	176
199 131 530	176
199 131 531	176
199 131 539	176
199 131 540	176
199 131 541	176
199 131 549	178
199 131 550	178
199 131 551	178
199 131 559	178
199 131 560	178
199 131 561	178
199 131 729	169
199 131 730	169
199 131 731	169
199 131 739	169
199 131 740	169
199 131 741	169

Index

Code	Page
199 131 767	175
199 131 768	175
199 131 769	175
199 131 770	175
199 131 771	175
199 131 777	175
199 131 778	175
199 131 779	175
199 131 780	175
199 131 781	175
199 140 322	276
199 140 323	276
199 140 324	276
199 140 325	276
199 140 326	276
199 140 327	276
199 140 328	276
199 140 342	276
199 140 343	276
199 140 344	276
199 140 345	276
199 140 346	276
199 140 347	276
199 140 348	276
199 140 362	277
199 140 363	277
199 140 364	277
199 140 365	277
199 140 366	277
199 140 367	277
199 140 368	277
199 140 369	277
199 140 370	277
199 140 371	277
199 140 372	277
199 140 373	277
199 140 374	277
199 140 375	277
199 140 382	277
199 140 383	277
199 140 384	277
199 140 385	277
199 140 386	277
199 140 387	277
199 140 388	277
199 140 389	277
199 140 390	277
199 140 391	277
199 140 392	277
199 140 393	277
199 140 394	277
199 140 395	277
199 140 402	279
199 140 403	279
199 140 404	279
199 140 405	279
199 140 406	279
199 140 407	279
199 140 408	279
199 140 422	279
199 140 423	279
199 140 424	279
199 140 425	279
199 140 426	279
199 140 427	279
199 140 428	279
199 140 442	280
199 140 443	280

Code	Page
199 140 444	280
199 140 445	280
199 140 446	280
199 140 447	280
199 140 448	280
199 140 449	280
199 140 450	280
199 140 462	280
199 140 463	280
199 140 464	280
199 140 465	280
199 140 466	280
199 140 467	280
199 140 468	280
199 140 469	280
199 140 470	280
199 140 802	277
199 140 803	277
199 140 804	277
199 140 805	277
199 140 806	277
199 140 807	277
199 140 808	277
199 140 809	277
199 140 810	277
199 140 822	280
199 140 823	280
199 140 824	280
199 140 825	280
199 140 826	280
199 140 827	280
199 140 828	280
199 140 829	280
199 140 830	280
199 140 842	276
199 140 843	276
199 140 844	276
199 140 845	276
199 140 846	276
199 140 847	276
199 140 848	276
199 140 862	279
199 140 863	279
199 140 864	279
199 140 865	279
199 140 866	279
199 140 867	279
199 140 868	279
199 141 322	282
199 141 323	282
199 141 324	282
199 141 325	282
199 141 326	282
199 141 327	282
199 141 328	282
199 141 342	282
199 141 343	282
199 141 344	282
199 141 345	282
199 141 346	282
199 141 347	282
199 141 348	282
199 141 362	281
199 141 363	281
199 141 364	281
199 141 365	281
199 141 366	281
199 141 367	281

Code	Page
199 141 368	281
199 141 382	281
199 141 383	281
199 141 384	281
199 141 385	281
199 141 386	281
199 141 387	281
199 141 388	281
199 141 402	284
199 141 403	284
199 141 404	284
199 141 405	284
199 141 406	284
199 141 407	284
199 141 408	284
199 141 422	284
199 141 423	284
199 141 424	284
199 141 425	284
199 141 426	284
199 141 427	284
199 141 428	284
199 141 442	283
199 141 443	283
199 141 444	283
199 141 445	283
199 141 446	283
199 141 447	283
199 141 448	283
199 141 462	283
199 141 463	283
199 141 464	283
199 141 465	283
199 141 466	283
199 141 467	283
199 141 468	283
199 141 802	281
199 141 803	281
199 141 804	281
199 141 805	281
199 141 806	281
199 141 807	281
199 141 808	281
199 141 822	283
199 141 823	283
199 141 824	283
199 141 825	283
199 141 826	283
199 141 827	283
199 141 828	283
199 141 842	282
199 141 843	282
199 141 844	282
199 141 845	282
199 141 846	282
199 141 847	282
199 141 848	282
199 141 862	284
199 141 863	284
199 141 864	284
199 141 865	284
199 141 866	284
199 141 867	284
199 141 868	284
199 142 322	286
199 142 323	286
199 142 324	286
199 142 325	286

Index

Code	Page
199 142 326	286
199 142 327	286
199 142 328	286
199 142 342	286
199 142 343	286
199 142 344	286
199 142 345	286
199 142 346	286
199 142 347	286
199 142 348	286
199 142 362	285
199 142 363	285
199 142 364	285
199 142 365	285
199 142 366	285
199 142 367	285
199 142 368	285
199 142 382	285
199 142 383	285
199 142 384	285
199 142 385	285
199 142 386	285
199 142 387	285
199 142 388	285
199 142 402	288
199 142 403	288
199 142 404	288
199 142 405	288
199 142 406	288
199 142 407	288
199 142 408	288
199 142 422	288
199 142 423	288
199 142 424	288
199 142 425	288
199 142 426	288
199 142 427	288
199 142 428	288
199 142 442	287
199 142 443	287
199 142 444	287
199 142 445	287
199 142 446	287
199 142 447	287
199 142 448	287
199 142 462	287
199 142 463	287
199 142 464	287
199 142 465	287
199 142 466	287
199 142 467	287
199 142 468	287
199 142 802	285
199 142 803	285
199 142 804	285
199 142 805	285
199 142 806	285
199 142 807	285
199 142 808	285
199 142 822	287
199 142 823	287
199 142 824	287
199 142 825	287
199 142 826	287
199 142 827	287
199 142 828	287
199 142 842	286
199 142 843	286

Code	Page
199 142 844	286
199 142 845	286
199 142 846	286
199 142 847	286
199 142 848	286
199 142 862	288
199 142 863	288
199 142 864	288
199 142 865	288
199 142 866	288
199 142 867	288
199 142 868	288
199 166 000	317
199 166 001	317
199 166 002	317
199 166 005	317
199 166 006	317
199 166 007	317
199 166 010	317
199 166 011	317
199 166 012	317
199 166 015	317
199 166 016	317
199 166 017	317
199 166 150	318
199 166 151	318
199 166 155	318
199 166 156	318
199 166 160	318
199 166 161	318
199 166 165	318
199 166 166	318
199 166 201	319
199 166 206	319
199 166 211	319
199 166 216	319
199 186 002	182
199 186 003	182
199 186 004	182
199 186 005	182
199 186 006	182
199 186 007	182
199 186 008	182
199 186 012	182
199 186 013	182
199 186 014	182
199 186 015	182
199 186 016	182
199 186 017	182
199 186 018	182
199 186 022	180
199 186 023	180
199 186 024	180
199 186 025	180
199 186 026	180
199 186 027	180
199 186 028	180
199 186 032	180
199 186 033	180
199 186 034	180
199 186 035	180
199 186 036	180
199 186 037	180
199 186 038	180
199 186 042	190
199 186 043	190
199 186 044	190
199 186 045	190

Code	Page
199 186 046	190
199 186 047	190
199 186 048	190
199 186 052	190
199 186 053	190
199 186 054	190
199 186 055	190
199 186 056	190
199 186 057	190
199 186 058	190
199 186 062	188
199 186 063	188
199 186 064	188
199 186 065	188
199 186 066	188
199 186 067	188
199 186 068	188
199 186 072	188
199 186 073	188
199 186 074	188
199 186 075	188
199 186 076	188
199 186 077	188
199 186 078	188
199 186 083	183
199 186 084	183
199 186 085	183
199 186 086	183
199 186 087	183
199 186 088	183
199 186 093	183
199 186 094	183
199 186 095	183
199 186 096	183
199 186 097	183
199 186 098	183
199 186 103	191
199 186 104	191
199 186 105	191
199 186 106	191
199 186 107	191
199 186 108	191
199 186 113	191
199 186 114	191
199 186 115	191
199 186 116	191
199 186 117	191
199 186 118	191
199 186 122	181
199 186 123	181
199 186 124	181
199 186 125	181
199 186 126	181
199 186 127	181
199 186 128	181
199 186 132	181
199 186 133	181
199 186 134	181
199 186 135	181
199 186 136	181
199 186 137	181
199 186 138	181
199 186 142	189
199 186 143	189
199 186 144	189
199 186 145	189
199 186 146	189
199 186 147	189

Index

Code	Page
199 186 148	189
199 186 152	189
199 186 153	189
199 186 154	189
199 186 155	189
199 186 156	189
199 186 157	189
199 186 158	189
199 186 162	186
199 186 163	186
199 186 164	186
199 186 165	186
199 186 166	186
199 186 167	186
199 186 168	186
199 186 172	186
199 186 173	186
199 186 174	186
199 186 175	186
199 186 176	186
199 186 177	186
199 186 178	186
199 186 182	184
199 186 183	184
199 186 184	184
199 186 185	184
199 186 186	184
199 186 187	184
199 186 188	184
199 186 192	184
199 186 193	184
199 186 194	184
199 186 195	184
199 186 196	184
199 186 197	184
199 186 198	184
199 186 202	194
199 186 203	194
199 186 204	194
199 186 205	194
199 186 206	194
199 186 207	194
199 186 208	194
199 186 212	194
199 186 213	194
199 186 214	194
199 186 215	194
199 186 216	194
199 186 217	194
199 186 218	194
199 186 222	192
199 186 223	192
199 186 224	192
199 186 225	192
199 186 226	192
199 186 227	192
199 186 228	192
199 186 232	192
199 186 233	192
199 186 234	192
199 186 235	192
199 186 236	192
199 186 237	192
199 186 238	192
199 186 243	187
199 186 244	187
199 186 245	187
199 186 246	187

Code	Page
199 186 247	187
199 186 248	187
199 186 253	187
199 186 254	187
199 186 255	187
199 186 256	187
199 186 257	187
199 186 258	187
199 186 263	195
199 186 264	195
199 186 265	195
199 186 266	195
199 186 267	195
199 186 268	195
199 186 273	195
199 186 274	195
199 186 275	195
199 186 276	195
199 186 277	195
199 186 278	195
199 186 282	185
199 186 283	185
199 186 284	185
199 186 285	185
199 186 286	185
199 186 287	185
199 186 288	185
199 186 292	185
199 186 293	185
199 186 294	185
199 186 295	185
199 186 296	185
199 186 297	185
199 186 298	185
199 186 302	193
199 186 303	193
199 186 304	193
199 186 305	193
199 186 306	193
199 186 307	193
199 186 308	193
199 186 312	193
199 186 313	193
199 186 314	193
199 186 315	193
199 186 316	193
199 186 317	193
199 186 318	193
199 190 001	603
199 190 029	603
199 190 080	587
199 190 081	587
199 190 082	587
199 190 083	587
199 190 084	587
199 190 085	586
199 190 086	586
199 190 087	586
199 190 092	586
199 190 093	588
199 190 094	588
199 190 095	588
199 190 096	588
199 190 097	588
199 190 099	587
199 190 100	587
199 190 101	587
199 190 108	603

Code	Page
199 190 109	603
199 190 275	583
199 190 281	583
199 190 282	583
199 190 283	583
199 190 284	584
199 190 285	584
199 190 286	584
199 190 287	584
199 190 293	592
199 190 294	592
199 190 295	592
199 190 296	592
199 190 297	592
199 190 298	592
199 190 302	599
199 190 303	599
199 190 304	599
199 190 305	592
199 190 306	592
199 190 307	592
199 190 308	592
199 190 309	592
199 190 310	593
199 190 311	605
199 190 318	594
199 190 319	594
199 190 348	604
199 190 349	604
199 190 350	604
199 190 351	604
199 190 357	599
199 190 358	599
199 190 359	599
199 190 360	599
199 190 361	599
199 190 372	605
199 190 373	605
199 190 378	583
199 190 379	594
199 190 381	594
199 190 382	594
199 190 383	594
199 190 384	594
199 190 385	594
199 190 387	593
199 190 388	593
199 190 389	593
199 190 395	604
199 190 405	592
199 190 414	604
199 190 415	604
199 190 416	604
199 190 417	603
199 190 418	603
199 190 419	604
199 190 424	600
199 190 425	601
199 190 426	600
199 190 427	601
199 190 428	601
199 190 429	601
199 190 430	600
199 190 431	600
199 190 432	601
199 190 433	601
199 190 434	601
199 190 435	600

Index

Code	Page
199 190 436	600
199 190 456	607
199 190 457	607
199 190 458	608
199 190 462	593
199 190 464	593
199 190 467	607
199 190 468	607
199 190 498	595
199 190 499	595
199 190 500	595
199 190 501	595
199 190 510	595
199 190 511	595
199 190 512	595
199 190 513	595
199 190 518	597
199 190 519	597
199 190 520	597
199 190 521	597
199 190 522	597
199 190 523	597
199 190 532	598
199 190 533	598
199 190 534	598
199 190 535	598
199 190 540	598
199 190 541	598
199 190 542	598
199 190 543	598
199 190 544	598
199 190 545	598
199 190 546	596
199 190 547	596
199 190 554	598
199 190 555	598
199 190 560	606
199 190 561	596
199 190 562	606
199 190 565	606
199 190 566	606
199 190 567	606
199 190 568	608
199 190 569	608
199 190 571	597
199 190 572	596
199 190 573	597
199 190 574	596
199 190 575	603
199 190 576	603
199 190 577	603
199 190 578	597
199 190 579	597
199 190 580	597
199 190 581	597
199 192 160	605
199 192 161	605
199 192 162	605
199 192 163	605
199 231 002	198
199 231 003	198
199 231 004	198
199 231 005	198
199 231 006	198
199 231 007	198
199 231 008	198
199 231 012	198
199 231 013	198

Code	Page
199 231 014	198
199 231 015	198
199 231 016	198
199 231 017	198
199 231 018	198
199 231 022	199
199 231 023	199
199 231 024	199
199 231 025	199
199 231 026	199
199 231 027	199
199 231 028	199
199 231 032	199
199 231 033	199
199 231 034	199
199 231 035	199
199 231 036	199
199 231 037	199
199 231 038	199
199 231 042	202
199 231 043	202
199 231 044	202
199 231 045	202
199 231 046	202
199 231 047	202
199 231 048	202
199 231 052	202
199 231 053	202
199 231 054	202
199 231 055	202
199 231 056	202
199 231 057	202
199 231 058	202
199 231 062	203
199 231 063	203
199 231 064	203
199 231 065	203
199 231 066	203
199 231 067	203
199 231 068	203
199 231 072	203
199 231 073	203
199 231 074	203
199 231 075	203
199 231 076	203
199 231 077	203
199 231 078	203
199 231 082	206
199 231 083	206
199 231 084	206
199 231 085	206
199 231 086	206
199 231 087	206
199 231 088	206
199 231 092	206
199 231 093	206
199 231 094	206
199 231 095	206
199 231 096	206
199 231 097	206
199 231 098	206
199 231 102	207
199 231 103	207
199 231 104	207
199 231 105	207
199 231 106	207
199 231 107	207
199 231 108	207

Code	Page
199 231 112	207
199 231 113	207
199 231 114	207
199 231 115	207
199 231 116	207
199 231 117	207
199 231 118	207
199 231 122	210
199 231 123	210
199 231 124	210
199 231 125	210
199 231 126	210
199 231 127	210
199 231 128	210
199 231 129	210
199 231 130	210
199 231 131	210
199 231 132	210
199 231 133	210
199 231 134	210
199 231 135	210
199 231 136	210
199 231 137	210
199 231 138	210
199 231 139	210
199 231 140	210
199 231 141	210
199 231 142	211
199 231 143	211
199 231 144	211
199 231 145	211
199 231 146	211
199 231 147	211
199 231 148	211
199 231 149	211
199 231 150	211
199 231 151	211
199 231 152	211
199 231 153	211
199 231 154	211
199 231 155	211
199 231 156	211
199 231 157	211
199 231 158	211
199 231 159	211
199 231 160	211
199 231 161	211
199 231 162	216
199 231 163	216
199 231 164	216
199 231 165	216
199 231 166	216
199 231 167	216
199 231 168	216
199 231 169	216
199 231 170	216
199 231 171	216
199 231 172	216
199 231 173	216
199 231 174	216
199 231 175	216
199 231 176	216
199 231 177	216
199 231 178	216
199 231 179	216
199 231 180	216
199 231 181	216
199 231 182	217

Index

Code	Page
199 231 183	217
199 231 184	217
199 231 185	217
199 231 186	217
199 231 187	217
199 231 188	217
199 231 189	217
199 231 190	217
199 231 191	217
199 231 192	217
199 231 193	217
199 231 194	217
199 231 195	217
199 231 196	217
199 231 197	217
199 231 198	217
199 231 199	217
199 231 200	217
199 231 201	217
199 231 202	222
199 231 203	222
199 231 204	222
199 231 205	222
199 231 206	222
199 231 207	222
199 231 208	222
199 231 209	222
199 231 210	222
199 231 211	222
199 231 212	222
199 231 213	222
199 231 214	222
199 231 215	222
199 231 216	222
199 231 217	222
199 231 218	222
199 231 219	222
199 231 220	222
199 231 221	222
199 231 222	223
199 231 223	223
199 231 224	223
199 231 225	223
199 231 226	223
199 231 227	223
199 231 228	223
199 231 229	223
199 231 230	223
199 231 231	223
199 231 232	223
199 231 233	223
199 231 234	223
199 231 235	223
199 231 236	223
199 231 237	223
199 231 238	223
199 231 239	223
199 231 240	223
199 231 241	223
199 231 243	201
199 231 244	201
199 231 245	201
199 231 246	201
199 231 247	201
199 231 248	201
199 231 253	201
199 231 254	201
199 231 255	201

Code	Page
199 231 256	201
199 231 257	201
199 231 258	201
199 231 263	205
199 231 264	205
199 231 265	205
199 231 266	205
199 231 267	205
199 231 268	205
199 231 273	205
199 231 274	205
199 231 275	205
199 231 276	205
199 231 277	205
199 231 278	205
199 231 283	209
199 231 284	209
199 231 285	209
199 231 286	209
199 231 287	209
199 231 288	209
199 231 293	209
199 231 294	209
199 231 295	209
199 231 296	209
199 231 297	209
199 231 298	209
199 231 329	213
199 231 330	213
199 231 331	213
199 231 339	213
199 231 340	213
199 231 341	213
199 231 349	219
199 231 350	219
199 231 351	219
199 231 359	219
199 231 360	219
199 231 361	219
199 231 369	225
199 231 370	225
199 231 371	225
199 231 379	225
199 231 380	225
199 231 381	225
199 231 423	212
199 231 424	212
199 231 425	212
199 231 426	212
199 231 427	212
199 231 428	212
199 231 433	212
199 231 434	212
199 231 435	212
199 231 436	212
199 231 437	212
199 231 438	212
199 231 443	218
199 231 444	218
199 231 445	218
199 231 446	218
199 231 447	218
199 231 448	218
199 231 453	218
199 231 454	218
199 231 455	218
199 231 456	218
199 231 457	218

Code	Page
199 231 458	218
199 231 463	224
199 231 464	224
199 231 465	224
199 231 466	224
199 231 467	224
199 231 468	224
199 231 473	224
199 231 474	224
199 231 475	224
199 231 476	224
199 231 477	224
199 231 478	224
199 231 623	200
199 231 624	200
199 231 625	200
199 231 626	200
199 231 627	200
199 231 628	200
199 231 633	200
199 231 634	200
199 231 635	200
199 231 636	200
199 231 637	200
199 231 638	200
199 231 643	204
199 231 644	204
199 231 645	204
199 231 646	204
199 231 647	204
199 231 648	204
199 231 653	204
199 231 654	204
199 231 655	204
199 231 656	204
199 231 657	204
199 231 658	204
199 231 663	208
199 231 664	208
199 231 665	208
199 231 666	208
199 231 667	208
199 231 668	208
199 231 673	208
199 231 674	208
199 231 675	208
199 231 676	208
199 231 677	208
199 231 678	208
199 231 833	214
199 231 834	214
199 231 835	214
199 231 836	214
199 231 837	214
199 231 838	214
199 231 839	214
199 231 840	214
199 231 841	214
199 231 843	214
199 231 844	214
199 231 845	214
199 231 846	214
199 231 847	214
199 231 848	214
199 231 849	214
199 231 850	214
199 231 851	214
199 231 853	220

Index

Code	Page
199 231 854	220
199 231 855	220
199 231 856	220
199 231 857	220
199 231 858	220
199 231 859	220
199 231 860	220
199 231 861	220
199 231 863	220
199 231 864	220
199 231 865	220
199 231 866	220
199 231 867	220
199 231 868	220
199 231 869	220
199 231 870	220
199 231 871	220
199 231 873	226
199 231 874	226
199 231 875	226
199 231 876	226
199 231 877	226
199 231 878	226
199 231 879	226
199 231 880	226
199 231 881	226
199 231 883	226
199 231 884	226
199 231 885	226
199 231 886	226
199 231 887	226
199 231 888	226
199 231 889	226
199 231 890	226
199 231 891	226
199 231 937	215
199 231 938	215
199 231 939	215
199 231 940	215
199 231 941	215
199 231 947	215
199 231 948	215
199 231 949	215
199 231 950	215
199 231 951	215
199 231 959	221
199 231 960	221
199 231 961	221
199 231 969	221
199 231 970	221
199 231 971	221
199 231 977	227
199 231 978	227
199 231 979	227
199 231 980	227
199 231 981	227
199 231 987	227
199 231 988	227
199 231 989	227
199 231 990	227
199 231 991	227
199 240 282	289
199 240 283	289
199 240 284	289
199 240 285	289
199 240 286	289
199 240 287	289
199 240 288	289

Code	Page
199 240 289	289
199 240 290	289
199 240 302	289
199 240 303	289
199 240 304	289
199 240 305	289
199 240 306	289
199 240 307	289
199 240 308	289
199 240 309	289
199 240 310	289
199 240 322	290
199 240 323	290
199 240 324	290
199 240 325	290
199 240 326	290
199 240 327	290
199 240 328	290
199 240 329	290
199 240 330	290
199 240 342	290
199 240 343	290
199 240 344	290
199 240 345	290
199 240 346	290
199 240 347	290
199 240 348	290
199 240 349	290
199 240 350	290
199 240 362	291
199 240 363	291
199 240 364	291
199 240 365	291
199 240 366	291
199 240 367	291
199 240 368	291
199 240 369	291
199 240 370	291
199 240 371	291
199 240 372	291
199 240 373	291
199 240 374	291
199 240 375	291
199 240 382	291
199 240 383	291
199 240 384	291
199 240 385	291
199 240 386	291
199 240 387	291
199 240 388	291
199 240 389	291
199 240 390	291
199 240 391	291
199 240 392	291
199 240 393	291
199 240 394	291
199 240 395	291
199 240 702	289
199 240 703	289
199 240 704	289
199 240 705	289
199 240 706	289
199 240 707	289
199 240 708	289
199 240 709	289
199 240 710	289
199 240 722	290
199 240 723	290

Code	Page
199 240 724	290
199 240 725	290
199 240 726	290
199 240 727	290
199 240 728	290
199 240 729	290
199 240 730	290
199 240 742	291
199 240 743	291
199 240 744	291
199 240 745	291
199 240 746	291
199 240 747	291
199 240 748	291
199 240 749	291
199 240 750	291
199 241 282	292
199 241 283	292
199 241 284	292
199 241 285	292
199 241 286	292
199 241 287	292
199 241 288	292
199 241 302	292
199 241 303	292
199 241 304	292
199 241 305	292
199 241 306	292
199 241 307	292
199 241 308	292
199 241 322	293
199 241 323	293
199 241 324	293
199 241 325	293
199 241 326	293
199 241 327	293
199 241 328	293
199 241 342	293
199 241 343	293
199 241 344	293
199 241 345	293
199 241 346	293
199 241 347	293
199 241 348	293
199 241 362	294
199 241 363	294
199 241 364	294
199 241 365	294
199 241 366	294
199 241 367	294
199 241 368	294
199 241 382	294
199 241 383	294
199 241 384	294
199 241 385	294
199 241 386	294
199 241 387	294
199 241 388	294
199 241 702	292
199 241 703	292
199 241 704	292
199 241 705	292
199 241 706	292
199 241 707	292
199 241 708	292
199 241 722	293
199 241 723	293
199 241 724	293

Index

Code	Page
199 241 725	293
199 241 726	293
199 241 727	293
199 241 728	293
199 241 742	294
199 241 743	294
199 241 744	294
199 241 745	294
199 241 746	294
199 241 747	294
199 241 748	294
199 242 282	295
199 242 283	295
199 242 284	295
199 242 285	295
199 242 286	295
199 242 287	295
199 242 288	295
199 242 302	295
199 242 303	295
199 242 304	295
199 242 305	295
199 242 306	295
199 242 307	295
199 242 308	295
199 242 322	296
199 242 323	296
199 242 324	296
199 242 325	296
199 242 326	296
199 242 327	296
199 242 328	296
199 242 342	296
199 242 343	296
199 242 344	296
199 242 345	296
199 242 346	296
199 242 347	296
199 242 348	296
199 242 362	297
199 242 363	297
199 242 364	297
199 242 365	297
199 242 366	297
199 242 367	297
199 242 368	297
199 242 382	297
199 242 383	297
199 242 384	297
199 242 385	297
199 242 386	297
199 242 387	297
199 242 388	297
199 242 702	295
199 242 703	295
199 242 704	295
199 242 705	295
199 242 706	295
199 242 707	295
199 242 708	295
199 242 722	296
199 242 723	296
199 242 724	296
199 242 725	296
199 242 726	296
199 242 727	296
199 242 728	296
199 242 742	297

Code	Page
199 242 743	297
199 242 744	297
199 242 745	297
199 242 746	297
199 242 747	297
199 242 748	297
199 286 002	230
199 286 003	230
199 286 004	230
199 286 005	230
199 286 006	230
199 286 007	230
199 286 008	230
199 286 012	230
199 286 013	230
199 286 014	230
199 286 015	230
199 286 016	230
199 286 017	230
199 286 018	230
199 286 022	228
199 286 023	228
199 286 024	228
199 286 025	228
199 286 026	228
199 286 027	228
199 286 028	228
199 286 032	228
199 286 033	228
199 286 034	228
199 286 035	228
199 286 036	228
199 286 037	228
199 286 038	228
199 286 042	238
199 286 043	238
199 286 044	238
199 286 045	238
199 286 046	238
199 286 047	238
199 286 048	238
199 286 052	238
199 286 053	238
199 286 054	238
199 286 055	238
199 286 056	238
199 286 057	238
199 286 058	238
199 286 062	236
199 286 063	236
199 286 064	236
199 286 065	236
199 286 066	236
199 286 067	236
199 286 068	236
199 286 072	236
199 286 073	236
199 286 074	236
199 286 075	236
199 286 076	236
199 286 077	236
199 286 078	236
199 286 083	231
199 286 084	231
199 286 085	231
199 286 086	231
199 286 087	231
199 286 088	231

Code	Page
199 286 093	231
199 286 094	231
199 286 095	231
199 286 096	231
199 286 097	231
199 286 098	231
199 286 103	239
199 286 104	239
199 286 105	239
199 286 106	239
199 286 107	239
199 286 108	239
199 286 113	239
199 286 114	239
199 286 115	239
199 286 116	239
199 286 117	239
199 286 118	239
199 286 122	229
199 286 123	229
199 286 124	229
199 286 125	229
199 286 126	229
199 286 127	229
199 286 128	229
199 286 132	229
199 286 133	229
199 286 134	229
199 286 135	229
199 286 136	229
199 286 137	229
199 286 138	229
199 286 142	237
199 286 143	237
199 286 144	237
199 286 145	237
199 286 146	237
199 286 147	237
199 286 148	237
199 286 152	237
199 286 153	237
199 286 154	237
199 286 155	237
199 286 156	237
199 286 157	237
199 286 158	237
199 286 162	234
199 286 163	234
199 286 164	234
199 286 165	234
199 286 166	234
199 286 167	234
199 286 168	234
199 286 172	234
199 286 173	234
199 286 174	234
199 286 175	234
199 286 176	234
199 286 177	234
199 286 178	234
199 286 182	232
199 286 183	232
199 286 184	232
199 286 185	232
199 286 186	232
199 286 187	232
199 286 188	232
199 286 192	232

Index

Code	Page
199 286 193	232
199 286 194	232
199 286 195	232
199 286 196	232
199 286 197	232
199 286 198	232
199 286 202	242
199 286 203	242
199 286 204	242
199 286 205	242
199 286 206	242
199 286 207	242
199 286 208	242
199 286 212	242
199 286 213	242
199 286 214	242
199 286 215	242
199 286 216	242
199 286 217	242
199 286 218	242
199 286 222	240
199 286 223	240
199 286 224	240
199 286 225	240
199 286 226	240
199 286 227	240
199 286 228	240
199 286 232	240
199 286 233	240
199 286 234	240
199 286 235	240
199 286 236	240
199 286 237	240
199 286 238	240
199 286 243	235
199 286 244	235
199 286 245	235
199 286 246	235
199 286 247	235
199 286 248	235
199 286 253	235
199 286 254	235
199 286 255	235
199 286 256	235
199 286 257	235
199 286 258	235
199 286 263	243
199 286 264	243
199 286 265	243
199 286 266	243
199 286 267	243
199 286 268	243
199 286 273	243
199 286 274	243
199 286 275	243
199 286 276	243
199 286 277	243
199 286 278	243
199 286 282	233
199 286 283	233
199 286 284	233
199 286 285	233
199 286 286	233
199 286 287	233
199 286 288	233
199 286 292	233
199 286 293	233
199 286 294	233

Code	Page
199 286 295	233
199 286 296	233
199 286 297	233
199 286 298	233
199 286 302	241
199 286 303	241
199 286 304	241
199 286 305	241
199 286 306	241
199 286 307	241
199 286 308	241
199 286 312	241
199 286 313	241
199 286 314	241
199 286 315	241
199 286 316	241
199 286 317	241
199 286 318	241
700 245 481	45
700 245 482	45
700 245 483	45
700 245 484	45
700 245 485	45
700 245 486	45
700 246 112	305
700 246 419	305
700 246 420	305
700 253 866	305
700 253 867	305
700 256 401	305
700 647 267	26
700 647 268	26
700 647 269	26
700 647 270	26
700 647 600	415
700 647 601	415
700 647 602	415
700 647 603	415
700 647 604	415
700 647 605	415
700 647 606	415
700 647 607	415
700 647 608	415
700 647 609	415
700 647 610	415
700 647 611	415
700 647 612	415
700 647 613	415
700 647 614	415
700 647 615	415
700 647 616	415
700 647 617	415
700 647 618	415
700 647 619	415
700 647 620	415
700 647 621	415
700 647 622	415
700 647 623	415
700 647 624	415
700 647 625	415
700 647 626	415
700 647 627	415
700 647 628	415
700 647 629	415
700 647 630	415
700 647 631	415
700 647 632	415
700 647 633	415

Code	Page
700 647 634	415
700 647 635	415
700 647 636	415
700 647 637	415
700 647 638	415
700 647 639	415
700 647 640	415
700 647 641	415
700 647 642	415
700 647 643	415
700 647 644	415
700 647 645	415
700 647 646	415
700 647 647	415
700 647 648	415
700 647 649	415
700 647 650	416
700 647 651	416
700 647 652	416
700 647 653	416
700 647 654	416
700 647 655	416
700 647 656	416
700 647 657	416
700 647 658	416
700 647 659	416
700 647 660	416
700 647 661	416
700 647 662	416
700 647 663	416
700 647 664	416
700 647 665	416
700 647 666	416
700 647 667	416
700 647 668	416
700 647 669	416
700 647 670	416
700 647 671	416
700 647 672	416
700 647 673	416
700 647 674	416
700 647 675	416
700 647 676	416
700 647 677	416
700 647 678	416
700 647 679	416
700 647 680	416
700 647 681	416
700 647 682	416
700 647 683	416
700 647 684	416
700 647 685	416
700 647 686	416
700 647 687	416
700 647 688	416
700 647 689	416
700 647 690	416
700 647 691	416
700 647 692	416
700 647 693	416
700 647 694	416
700 647 695	416
700 647 696	416
700 647 697	416
700 647 698	416
700 647 699	416
700 647 700	28
700 647 701	28

Index

Code	Page
700 647 702	28
700 647 703	28
700 647 704	28
700 647 705	28
700 647 706	28
700 647 707	28
700 647 708	28
700 647 709	28
700 647 710	28
700 647 711	28
700 647 712	28
700 647 713	28
700 647 714	28
700 647 715	28
700 647 716	28
700 647 717	28
700 647 718	28
700 647 719	28
700 647 720	28
700 647 721	28
700 647 722	28
700 647 723	28
700 647 724	28
700 647 725	28
700 647 726	28
700 647 727	28
700 647 728	28
700 647 729	28
700 647 730	28
700 647 731	28
700 647 732	28
700 647 733	29
700 647 734	29
700 647 735	29
700 647 736	29
700 647 737	29
700 647 738	29
700 647 739	29
700 647 740	29
700 647 741	29
700 647 742	29
700 647 743	29
700 647 744	29
700 647 745	29
700 647 746	29
700 647 747	29
700 647 748	29
700 647 749	29
700 647 750	29
700 647 751	29
700 647 752	29
700 647 753	29
700 647 754	29
700 647 755	29
700 647 756	29
700 647 757	29
700 647 758	29
700 647 759	29
700 647 760	29
700 647 761	29
700 647 762	29
700 647 763	29
700 647 764	29
700 647 765	29
700 647 766	29
700 647 767	29
700 647 768	29
700 647 769	29

Code	Page
700 647 770	29
700 647 771	29
700 647 772	29
700 647 773	29
700 647 774	29
700 647 775	29
700 647 776	29
700 647 777	29
700 647 778	29
700 647 779	29
700 647 780	29
700 647 781	29
700 647 782	29
700 647 783	29
700 647 784	29
700 647 785	29
700 647 786	29
700 647 787	29
700 647 788	29
700 647 789	29
700 647 790	30
700 647 791	30
700 647 792	30
700 647 793	30
700 647 794	30
700 647 795	30
700 647 796	30
700 647 797	30
700 647 798	30
700 647 799	30
700 647 829	51
700 647 830	51
700 647 831	51
700 647 832	51
700 647 833	51
700 647 834	51
700 647 835	51
700 647 836	51
700 647 837	51
700 647 838	51
700 647 839	51
700 647 840	51
700 647 841	51
700 647 842	51
700 647 843	51
700 647 844	51
700 647 845	51
700 647 846	51
700 647 847	51
700 647 886	398
700 647 887	398
700 647 888	398
700 647 889	398
700 647 890	398
700 647 891	398
700 647 892	398
700 647 893	398
700 647 894	398
700 647 895	398
700 647 896	398
700 647 897	398
700 647 898	398
700 647 899	398
700 647 900	398
700 647 901	398
700 647 902	398
700 647 903	398
700 647 904	398

Code	Page
700 647 924	34
700 647 925	34
700 647 926	34
700 647 927	34
700 647 928	34
700 647 929	34
700 647 930	34
700 647 931	34
700 647 932	34
700 647 933	34
700 647 934	34
700 647 935	34
700 647 936	34
700 647 937	34
700 647 938	34
700 647 939	34
700 647 940	34
700 647 941	34
700 647 942	34
700 648 928	472
700 648 929	472
700 648 930	472
700 648 931	472
700 648 932	472
700 648 933	472
700 648 934	472
700 648 935	472
700 648 936	472
700 648 937	472
700 648 938	472
700 648 939	472
700 648 940	472
700 648 941	472
700 648 942	472
700 648 943	472
700 648 944	472
700 648 945	472
700 648 946	472
700 648 947	472
700 648 948	472
700 648 949	472
700 648 950	472
700 648 951	472
700 648 952	472
700 648 953	472
700 648 954	472
700 648 955	472
700 648 956	472
700 648 957	472
700 648 958	472
700 648 959	472
700 648 960	472
700 648 961	472
700 648 962	472
700 648 963	472
700 648 964	472
700 648 965	472
700 648 966	472
700 648 967	472
700 648 968	472
700 648 969	472
700 648 970	472
700 648 971	472
700 648 972	472
700 648 973	473
700 648 974	473
700 648 975	473
700 648 976	473

Index

Code	Page
700 648 977	473
700 648 978	473
700 648 979	473
700 648 980	473
700 648 981	473
700 648 982	473
700 648 983	473
700 648 984	473
700 648 985	473
700 648 986	473
700 648 987	473
700 648 988	473
700 648 989	473
700 648 990	473
700 648 991	473
700 648 992	473
700 648 993	473
700 648 994	473
700 648 995	473
700 648 996	473
700 648 997	473
700 648 998	473
700 648 999	473
700 649 000	473
700 649 001	473
700 649 002	473
700 649 003	473
700 649 004	473
700 649 005	473
700 649 006	473
700 649 007	473
700 649 008	473
700 649 009	473
700 649 010	473
700 649 011	473
700 649 012	473
700 649 013	473
700 649 014	473
700 649 015	473
700 649 016	473
700 649 017	474
700 649 018	474
700 649 019	474
700 649 020	474
700 649 021	474
700 649 022	474
700 649 023	474
700 649 024	474
700 649 025	474
700 649 026	474
700 649 028	474
700 649 029	474
700 649 030	474
700 649 031	474
700 649 032	474
700 649 033	474
700 649 034	474
700 649 035	474
700 649 036	474
700 649 037	474
700 649 038	474
700 649 039	474
700 649 040	474
700 649 041	474
700 649 042	474
700 649 043	474
700 649 044	474
700 649 045	474

Code	Page
700 649 046	474
700 649 047	474
700 649 048	474
700 649 049	474
700 649 050	474
700 649 051	474
700 649 052	474
700 649 053	474
700 649 054	474
700 649 055	474
700 649 056	405
700 649 057	405
700 649 058	405
700 649 059	405
700 649 060	405
700 649 061	405
700 649 062	405
700 649 063	405
700 649 064	405
700 649 065	405
700 649 066	405
700 649 067	405
700 649 068	405
700 649 069	405
700 649 070	405
700 649 071	405
700 649 072	406
700 649 073	406
700 649 074	406
700 649 075	406
700 649 076	406
700 649 077	406
700 649 078	406
700 649 079	406
700 649 080	406
700 649 081	406
700 649 082	406
700 649 083	406
700 649 084	406
700 649 085	406
700 649 086	406
700 649 087	406
700 649 088	408
700 649 089	408
700 649 090	408
700 649 091	408
700 649 092	408
700 649 093	408
700 649 094	408
700 649 095	408
700 649 096	408
700 649 097	408
700 649 098	408
700 649 099	408
700 649 100	408
700 649 101	408
700 649 102	408
700 649 103	408
700 649 104	408
700 649 105	408
700 649 106	408
700 649 107	408
700 649 108	408
700 649 109	408
700 649 110	408
700 649 111	409
700 649 112	409
700 649 113	409

Code	Page
700 649 114	409
700 649 115	409
700 649 116	409
700 649 117	409
700 649 118	409
700 649 119	409
700 649 120	409
700 649 121	409
700 649 122	409
700 649 123	409
700 649 124	409
700 649 125	409
700 649 126	409
700 649 127	409
700 649 128	409
700 649 129	409
700 649 130	409
700 649 131	409
700 649 132	409
700 649 133	409
700 649 134	409
700 649 135	409
700 649 136	409
700 649 137	409
700 649 138	409
700 649 139	409
700 649 140	409
700 649 141	409
700 649 142	409
700 649 143	409
700 649 144	409
700 649 145	409
700 649 146	409
700 649 147	409
700 649 148	409
700 649 149	409
700 649 150	409
700 649 151	409
700 649 152	409
700 649 153	409
700 649 154	409
700 649 155	407
700 649 156	407
700 649 157	407
700 649 158	407
700 649 159	407
700 649 160	407
700 649 161	407
700 649 162	407
700 649 163	407
700 649 164	407
700 649 165	407
700 649 166	407
700 649 167	407
700 649 168	407
700 649 169	407
700 649 170	407
700 649 171	407
700 649 172	407
700 649 173	407
700 649 174	407
700 649 175	407
700 649 176	407
700 649 177	407
700 649 178	407
700 649 179	407
700 649 180	407
700 649 181	407

Index

Code	Page
700 649 182	407
700 649 183	407
700 649 184	407
700 649 185	407
700 649 186	408
700 649 187	408
700 649 188	408
700 649 189	408
700 649 190	408
700 649 191	408
700 649 192	408
700 649 193	408
700 649 194	408
700 649 195	408
700 649 196	408
700 649 197	408
700 649 198	408
700 649 199	408
700 649 200	408
700 649 201	408
700 649 202	408
700 649 203	408
700 649 204	408
700 649 205	408
700 649 206	408
700 649 207	408
700 649 208	408
700 649 209	408
700 649 210	408
700 649 211	408
700 649 212	408
700 649 213	408
700 649 214	408
700 649 215	408
700 649 216	408
700 649 217	408
700 649 218	408
700 649 219	408
700 649 220	408
700 649 221	408
700 649 222	412
700 649 223	412
700 649 224	412
700 649 225	412
700 649 226	412
700 649 227	412
700 649 228	412
700 649 229	412
700 649 230	412
700 649 231	412
700 649 232	412
700 649 233	412
700 649 234	412
700 649 235	412
700 649 236	412
700 649 237	412
700 649 238	411
700 649 239	411
700 649 240	411
700 649 241	411
700 649 242	411
700 649 243	411
700 649 244	411
700 649 245	411
700 649 246	411
700 649 247	411
700 649 248	411
700 649 249	411

Code	Page
700 649 250	411
700 649 251	412
700 649 252	412
700 649 253	412
700 649 254	412
700 649 255	412
700 649 256	412
700 649 257	412
700 649 258	412
700 649 259	412
700 649 260	412
700 649 261	412
700 649 262	412
700 649 263	412
700 649 264	412
700 649 265	412
700 649 266	412
700 649 267	412
700 649 268	412
700 649 269	412
700 649 270	411
700 649 271	411
700 649 272	411
700 649 273	411
700 649 274	411
700 649 275	411
700 649 276	411
700 649 277	411
700 649 278	411
700 649 279	411
700 649 280	411
700 649 281	411
700 649 282	411
700 649 283	412
700 649 284	412
700 649 285	412
700 649 286	410
700 649 287	410
700 649 288	410
700 649 289	410
700 649 290	410
700 649 291	410
700 649 292	410
700 649 293	410
700 649 294	410
700 649 295	410
700 649 296	410
700 649 297	410
700 649 298	410
700 649 299	409
700 649 300	409
700 649 301	409
700 649 302	409
700 649 303	409
700 649 304	409
700 649 305	409
700 649 306	409
700 649 307	409
700 649 308	409
700 649 309	409
700 649 310	409
700 649 311	409
700 649 312	410
700 649 313	410
700 649 314	410
700 649 315	410
700 649 316	410
700 649 317	410

Code	Page
700 649 318	410
700 649 319	410
700 649 320	410
700 649 321	410
700 649 322	410
700 649 323	410
700 649 324	410
700 649 325	410
700 649 326	410
700 649 327	410
700 649 328	410
700 649 329	410
700 649 330	410
700 649 331	410
700 649 332	410
700 649 333	410
700 649 334	410
700 649 335	410
700 649 336	410
700 649 337	410
700 649 384	14
700 649 385	14
700 649 386	14
700 649 387	14
700 649 388	14
700 649 389	14
700 649 390	14
700 649 391	14
700 649 392	14
700 649 393	14
700 649 394	14
700 649 395	14
700 649 396	15
700 649 397	15
700 649 398	15
700 649 399	15
700 649 400	15
700 649 401	15
700 649 402	15
700 649 403	15
700 649 404	15
700 649 405	15
700 649 406	15
700 649 407	15
700 649 408	19
700 649 409	19
700 649 410	19
700 649 411	19
700 649 412	19
700 649 413	19
700 649 414	19
700 649 415	19
700 649 416	19
700 649 417	19
700 649 418	19
700 649 419	19
700 649 420	18
700 649 421	18
700 649 422	18
700 649 423	18
700 649 424	18
700 649 425	18
700 649 426	18
700 649 427	18
700 649 428	18
700 649 429	18
700 649 430	18
700 649 431	18

Index

Code	Page
700 649 432	18
700 649 433	18
700 649 434	18
700 649 435	18
700 649 436	18
700 649 437	18
700 649 438	18
700 649 439	18
700 649 440	18
700 649 441	18
700 649 442	18
700 649 443	18
700 649 444	17
700 649 445	17
700 649 446	17
700 649 447	17
700 649 448	17
700 649 449	17
700 649 450	17
700 649 451	17
700 649 452	17
700 649 453	17
700 649 454	17
700 649 455	17
700 649 457	19
700 649 458	19
700 649 459	19
700 649 460	19
700 649 461	19
700 649 462	19
700 649 463	19
700 649 464	19
700 649 465	19
700 649 466	19
700 649 467	19
700 649 468	19
700 649 469	19
700 649 470	19
700 649 471	19
700 649 472	19
700 649 473	19
700 649 474	19
700 649 475	19
700 649 476	19
700 649 477	19
700 649 478	19
700 649 479	19
700 649 480	19
700 649 481	21
700 649 482	21
700 649 483	21
700 649 484	21
700 649 485	21
700 649 486	21
700 649 487	21
700 649 488	21
700 649 489	21
700 649 490	21
700 649 491	21
700 649 492	21
700 649 493	23
700 649 494	23
700 649 495	23
700 649 496	23
700 649 497	23
700 649 498	23
700 649 499	23
700 649 500	23

Code	Page
700 649 501	23
700 649 502	23
700 649 503	23
700 649 504	23
700 649 505	23
700 649 506	23
700 649 507	23
700 649 508	23
700 649 509	23
700 649 510	23
700 649 511	23
700 649 512	23
700 649 513	23
700 649 514	23
700 649 515	23
700 649 516	23
700 649 517	23
700 649 518	23
700 649 519	23
700 649 520	23
700 649 521	23
700 649 523	23
700 649 524	23
700 649 525	23
700 649 526	23
700 649 527	23
700 649 528	23
700 649 529	23
700 649 530	23
700 649 531	23
700 649 532	23
700 649 533	23
700 649 534	23
700 649 535	23
700 649 536	23
700 649 537	23
700 649 538	23
700 649 539	23
700 649 540	23
700 649 541	23
700 649 542	23
700 649 543	23
700 649 544	23
700 649 545	23
700 649 546	23
700 649 547	24
700 649 548	24
700 649 549	24
700 649 550	24
700 649 551	24
700 649 552	24
700 649 553	24
700 649 554	24
700 649 555	24
700 649 556	24
700 649 557	24
700 649 558	24
700 649 559	24
700 649 560	24
700 649 561	24
700 649 562	24
700 649 563	24
700 649 564	24
700 649 565	24
700 649 566	24
700 649 567	24
700 649 568	24
700 649 569	24

Code	Page
700 649 570	24
700 649 571	24
700 649 572	24
700 649 573	24
700 649 574	24
700 649 575	24
700 649 576	24
700 649 577	24
700 649 578	24
700 649 579	24
700 649 580	24
700 649 581	24
700 649 582	24
700 649 583	24
700 649 584	24
700 649 585	24
700 649 586	24
700 649 587	24
700 649 588	26
700 649 589	26
700 649 590	26
700 649 591	26
700 649 592	26
700 649 593	26
700 649 594	26
700 649 595	26
700 649 596	26
700 649 597	27
700 649 598	27
700 649 599	27
700 649 600	26
700 649 601	26
700 649 602	26
700 649 603	26
700 649 604	26
700 649 605	26
700 649 606	26
700 649 607	26
700 649 608	26
700 649 609	27
700 649 610	27
700 649 611	27
700 649 612	27
700 649 613	27
700 649 614	27
700 649 615	27
700 649 616	27
700 649 617	27
700 649 618	27
700 649 619	27
700 649 620	27
700 649 621	27
700 649 622	27
700 649 623	27
700 649 624	27
700 649 625	27
700 649 626	27
700 649 627	27
700 649 628	27
700 649 629	27
700 649 630	27
700 649 631	27
700 649 632	27
700 649 633	27
700 649 634	27
700 649 635	27
700 649 636	24
700 649 637	24

Index

Code	Page
700 649 638	24
700 649 639	24
700 649 640	24
700 649 641	24
700 649 642	24
700 649 643	24
700 649 644	24
700 649 645	24
700 649 646	24
700 649 647	24
700 649 648	25
700 649 649	25
700 649 650	25
700 649 651	25
700 649 652	25
700 649 653	25
700 649 654	25
700 649 655	25
700 649 656	25
700 649 657	25
700 649 658	25
700 649 659	25
700 649 660	25
700 649 661	25
700 649 662	25
700 649 663	25
700 649 664	25
700 649 665	25
700 649 666	25
700 649 667	25
700 649 668	25
700 649 669	25
700 649 670	25
700 649 671	25
700 649 672	25
700 649 673	25
700 649 674	25
700 649 675	25
700 649 676	25
700 649 677	25
700 649 678	25
700 649 679	25
700 649 680	25
700 649 681	25
700 649 682	25
700 649 683	25
700 665 127	35
700 665 128	35
700 665 129	35
700 665 130	35
700 665 131	35
700 665 132	35
700 665 133	35
700 665 134	35
700 665 135	35
700 665 136	35
700 665 137	35
700 665 138	35
700 665 139	35
700 665 140	35
700 665 141	35
700 665 142	35
700 665 143	35
700 665 144	35
700 665 145	35
700 665 184	417
700 665 185	417
700 665 186	417

Code	Page
700 665 187	417
700 665 188	417
700 665 189	417
700 665 190	417
700 665 191	417
700 665 192	417
700 665 193	417
700 665 194	417
700 665 195	417
700 665 196	417
700 665 197	417
700 665 198	417
700 665 199	417
700 665 200	417
700 665 201	417
700 665 202	417
700 665 203	421
700 665 204	421
700 665 205	421
700 665 206	421
700 665 207	421
700 665 208	421
700 665 209	421
700 665 210	421
700 665 211	421
700 665 212	421
700 665 213	421
700 665 214	421
700 665 215	421
700 665 216	421
700 665 217	421
700 665 218	421
700 665 219	422
700 665 220	422
700 665 221	422
700 665 260	417
700 665 261	417
700 665 262	417
700 665 263	417
700 665 264	417
700 665 265	417
700 665 266	417
700 665 267	417
700 665 268	417
700 665 269	417
700 665 270	417
700 665 271	417
700 665 272	417
700 665 273	417
700 665 274	417
700 665 275	417
700 665 276	417
700 665 277	417
700 665 278	417
700 665 279	422
700 665 280	422
700 665 281	422
700 665 282	422
700 665 283	422
700 665 284	422
700 665 285	422
700 665 286	422
700 665 287	422
700 665 288	422
700 665 289	422
700 665 290	422
700 665 291	422
700 665 292	422

Code	Page
700 665 293	422
700 665 294	422
700 665 295	422
700 665 296	422
700 665 297	422
700 665 351	35
700 665 352	35
700 665 353	35
700 665 354	35
700 665 355	35
700 665 356	35
700 665 357	35
700 665 358	35
700 665 359	35
700 665 360	35
700 665 361	35
700 665 362	35
700 665 363	35
700 665 364	35
700 665 365	35
700 665 388	36
700 665 389	36
700 665 390	36
700 665 391	36
700 665 392	36
700 665 393	36
700 665 394	36
700 665 395	36
700 665 396	36
700 665 397	36
700 665 398	36
700 665 399	36
700 665 400	36
700 665 401	36
700 665 402	36
700 665 425	422
700 665 426	422
700 665 427	422
700 665 428	422
700 665 429	422
700 665 430	422
700 665 431	422
700 665 432	422
700 665 433	422
700 665 434	422
700 665 435	422
700 665 436	422
700 665 437	422
700 665 438	422
700 665 439	422
700 665 462	423
700 665 463	423
700 665 464	423
700 665 465	423
700 665 466	423
700 665 467	423
700 665 468	423
700 665 469	423
700 665 470	423
700 665 471	423
700 665 472	423
700 665 473	423
700 665 474	423
700 665 475	423
700 665 476	423
700 665 628	26
700 665 629	26
700 665 630	26

Index

Code	Page	Code	Page	Code	Page
700 665 631	26	701 480 477	438	720 600 253	67
700 665 632	26	701 480 478	438	720 910 007	455
700 665 633	26	701 480 479	438	720 910 008	455
700 665 634	26	701 480 480	438	720 910 009	455
700 665 635	26	701 480 481	438	720 910 010	455
700 665 636	26	701 480 482	438	720 910 011	456
700 665 637	26	701 480 483	438	720 910 017	455
700 665 638	26	701 480 489	438	720 910 018	455
700 665 639	26	701 480 490	438	720 910 019	455
700 665 644	26	701 480 491	438	720 910 020	455
700 665 645	26	701 480 492	438	720 910 021	455
700 665 646	26	701 480 493	438	720 910 028	455
700 665 647	26	701 480 494	438	720 910 029	455
700 665 648	26	701 485 560	458	720 910 030	455
700 665 649	26	701 485 561	458	720 910 031	456
700 665 650	26	701 485 562	458	720 910 040	455
700 665 651	26	701 485 563	458	720 910 041	456
700 665 652	26	701 485 564	458	720 920 007	459
700 665 653	26	701 485 565	458	720 920 008	459
700 665 654	26	720 100 007	457	720 920 009	459
700 665 655	26	720 100 008	457	720 920 010	459
700 665 656	411	720 100 009	457	720 920 011	459
700 665 657	411	720 100 010	457	720 920 017	459
700 665 658	411	720 100 011	457	720 920 018	459
700 665 659	411	720 100 017	457	720 920 019	459
700 665 660	411	720 100 018	457	720 920 020	459
700 665 661	411	720 100 019	457	720 920 021	459
700 665 662	411	720 100 020	457	720 920 028	459
700 665 663	411	720 100 021	457	720 920 029	459
700 665 664	411	720 100 029	457	720 920 030	459
700 665 665	411	720 100 040	457	720 920 031	459
700 665 666	411	720 100 041	457	720 920 040	459
700 665 667	411	720 100 258	456	720 920 041	459
700 665 668	411	720 100 259	456	720 920 208	459
700 665 669	411	720 100 260	456	720 920 209	459
700 665 670	411	720 100 261	456	720 920 210	459
700 665 671	411	720 100 281	456	720 920 211	459
700 665 672	411	720 100 282	456	720 920 221	459
700 665 673	411	720 100 283	456	720 920 231	459
700 665 674	411	720 100 756	456	720 920 241	459
700 665 675	411	720 100 757	456	720 920 258	455
700 665 676	411	720 100 758	456	720 920 259	455
700 665 677	411	720 100 759	456	720 920 260	455
700 665 678	411	720 100 760	456	720 920 261	455
700 665 679	411	720 100 761	456	720 920 281	455
700 665 680	411	720 100 766	456	720 920 282	455
700 665 681	411	720 100 767	456	720 920 283	455
700 665 682	411	720 100 771	456	720 920 706	460
700 665 683	411	720 100 772	456	720 920 707	460
701 474 382	438	720 100 776	456	720 920 708	460
701 474 383	438	720 100 777	456	720 920 709	460
701 474 386	438	720 100 782	456	720 920 710	460
701 474 387	438	720 100 783	456	720 920 711	460
701 474 388	438	720 600 236	67	720 920 718	460
701 474 390	438	720 600 237	67	720 920 719	460
701 474 391	438	720 600 238	67	720 920 720	460
701 474 392	438	720 600 239	67	720 920 721	460
701 474 393	438	720 600 240	67	720 920 728	460
701 474 394	438	720 600 241	67	720 920 729	460
701 474 395	438	720 600 242	67	720 920 730	460
701 474 396	438	720 600 243	67	720 920 731	460
701 474 397	438	720 600 246	67	720 920 754	454
701 474 398	438	720 600 247	67	720 920 756	454
701 474 399	438	720 600 248	67	720 920 757	454
701 474 400	438	720 600 249	67	720 920 758	455
701 474 401	438	720 600 250	67	720 920 759	455
701 480 475	438	720 600 251	67	720 920 760	455
701 480 476	438	720 600 252	67	720 920 761	455

Index

Code	Page
720 920 763	454
720 920 764	454
720 920 765	454
720 920 766	455
720 920 767	455
720 920 768	455
720 920 771	455
720 920 772	455
720 920 773	455
720 920 776	455
720 920 777	455
720 920 778	455
720 920 781	455
720 920 782	455
720 920 783	455
721 500 106	531
721 500 107	531
721 500 108	305
721 500 109	305
721 500 110	305
721 500 111	305
721 600 006	515
721 600 007	515
721 600 008	515
721 600 009	515
721 600 010	515
721 600 011	515
721 600 012	511
721 600 013	511
721 600 014	511
721 600 106	515
721 600 107	515
721 600 108	515
721 600 109	515
721 600 110	515
721 600 111	515
721 600 112	305
721 600 162	511
721 600 163	511
721 600 164	511
721 600 406	531
721 600 407	531
721 600 408	531
721 600 409	531
721 600 410	531
721 600 411	531
721 600 656	515
721 600 657	515
721 600 658	515
721 600 659	515
721 600 660	515
721 600 661	515
721 601 106	516
721 601 107	516
721 601 108	516
721 601 109	516
721 601 110	516
721 601 111	516
721 602 005	511
721 602 006	511
721 602 007	511
721 602 008	531
721 602 009	531
721 602 010	531
721 602 011	531
721 602 656	515
721 602 657	515
721 602 658	515

Code	Page
721 602 659	515
721 602 660	515
721 602 661	515
721 605 106	516
721 605 107	516
721 605 108	516
721 605 109	516
721 605 110	516
721 605 111	516
721 605 112	511
721 605 113	511
721 605 114	511
721 605 606	516
721 605 607	516
721 605 608	516
721 605 609	516
721 605 610	516
721 605 611	516
721 690 006	514
721 690 007	514
721 690 008	514
721 690 009	514
721 690 010	514
721 690 011	514
721 690 012	511
721 690 013	511
721 690 014	511
721 700 006	533
721 700 007	533
721 700 008	533
721 700 009	533
721 700 010	533
721 700 011	533
721 702 206	533
721 702 207	533
721 702 208	533
721 702 209	533
721 702 210	533
721 702 211	533
721 740 106	502
721 740 107	502
721 740 108	502
721 740 109	502
721 740 110	502
721 740 111	502
721 790 111	533
721 800 106	533
721 800 107	533
721 800 108	533
721 800 109	533
721 800 110	533
721 890 006	531
721 890 007	531
721 890 008	304
721 890 009	304
721 890 010	304
721 890 011	304
723 600 162	511
723 600 163	511
723 600 164	511
723 602 006	531
723 602 007	531
723 602 008	531
723 602 009	531
723 602 010	531
723 602 011	531
723 690 006	531
723 690 007	531

Code	Page
723 690 008	304
723 690 009	304
723 690 010	304
723 690 011	304
723 690 012	511
723 690 013	511
723 690 014	511
723 790 106	533
723 790 107	533
723 790 108	533
723 790 109	533
723 790 110	533
723 790 111	533
723 800 106	531
723 800 107	531
723 800 108	305
723 800 109	305
723 800 110	305
723 800 111	305
724 100 256	458
724 100 257	458
724 100 258	458
724 100 259	458
724 100 260	458
724 100 261	458
724 100 756	458
724 100 757	458
724 100 758	458
724 100 759	458
724 100 760	458
724 100 761	458
724 100 771	458
724 100 772	458
724 600 206	67
724 600 207	67
724 600 208	67
724 600 209	67
724 600 210	67
724 600 211	67
724 600 806	67
724 600 807	67
724 600 808	67
724 600 809	67
724 600 810	67
724 600 811	67
724 700 319	437
724 700 320	437
724 700 321	437
724 700 322	437
724 700 323	437
724 700 324	437
724 700 325	437
724 700 426	55
724 700 427	55
724 700 428	55
724 700 429	55
724 700 430	55
724 700 431	55
724 700 432	55
724 705 026	439
724 705 130	439
724 705 131	439
724 705 132	439
724 705 133	439
724 705 134	439
724 920 206	459
724 920 207	459
724 920 208	459

Index

Code	Page	Code	Page	Code	Page
724 920 209	459	727 018 614	14	727 158 521	16
724 920 210	459	727 018 635	15	727 158 522	16
724 920 211	459	727 018 636	15	727 158 523	16
724 920 256	457	727 018 637	15	727 158 524	17
724 920 257	457	727 018 638	15	727 158 525	17
724 920 258	457	727 018 639	15	727 158 526	17
724 920 259	457	727 018 662	349	727 158 527	17
724 920 260	457	727 018 663	349	727 158 535	17
724 920 261	457	727 018 664	349	727 158 536	17
724 920 706	458	727 018 681	349	727 158 540	17
724 920 707	458	727 018 682	349	727 158 541	17
724 920 708	458	727 018 683	349	727 158 542	17
724 920 709	458	727 018 684	349	727 158 544	17
724 920 710	459	727 018 685	349	727 158 545	17
724 920 711	459	727 018 686	349	727 158 546	17
724 920 719	458	727 100 105	56	727 158 547	17
724 920 721	459	727 100 106	56	727 158 548	17
724 920 756	457	727 100 107	56	727 158 549	18
724 920 757	457	727 100 108	56	727 158 550	18
724 920 758	457	727 100 109	56	727 158 551	18
724 920 759	457	727 100 110	56	727 158 552	18
724 920 760	457	727 100 111	56	727 158 581	349
724 920 761	457	727 100 112	56	727 158 582	349
724 920 771	457	727 100 113	56	727 158 583	349
724 920 772	457	727 100 114	56	727 158 584	349
727 018 421	15	727 100 206	59	727 158 585	349
727 018 422	15	727 100 207	59	727 158 586	349
727 018 423	15	727 100 208	59	727 158 587	349
727 018 440	15	727 100 209	59	727 158 588	349
727 018 441	15	727 108 506	16	727 158 589	350
727 018 442	15	727 108 507	16	727 158 590	350
727 018 443	15	727 108 508	16	727 158 591	350
727 018 444	15	727 108 509	16	727 158 592	350
727 018 445	15	727 108 510	16	727 158 594	350
727 018 450	349	727 108 511	16	727 158 595	350
727 018 451	349	727 108 581	349	727 158 596	350
727 018 452	349	727 108 582	349	727 158 597	350
727 018 475	349	727 108 583	349	727 158 598	350
727 018 476	349	727 108 584	349	727 200 105	56
727 018 477	349	727 108 585	349	727 200 106	56
727 018 478	349	727 108 586	349	727 200 107	56
727 018 479	349	727 150 105	56	727 200 108	56
727 018 480	349	727 150 106	56	727 200 109	56
727 018 490	14	727 150 107	56	727 200 110	56
727 018 491	14	727 150 108	56	727 200 111	56
727 018 492	14	727 150 109	56	727 200 112	56
727 018 493	14	727 150 110	56	727 200 113	56
727 018 494	14	727 150 111	56	727 200 114	56
727 018 495	14	727 150 112	56	727 200 206	59
727 018 521	14	727 150 113	56	727 200 207	59
727 018 522	14	727 150 114	56	727 200 208	59
727 018 523	14	727 158 412	17	727 200 209	59
727 018 549	15	727 158 413	17	727 208 251	350
727 018 550	15	727 158 414	17	727 208 252	350
727 018 551	16	727 158 506	16	727 208 253	350
727 018 552	16	727 158 507	16	727 208 254	350
727 018 574	14	727 158 508	16	727 208 255	350
727 018 575	14	727 158 509	16	727 208 257	350
727 018 576	15	727 158 510	16	727 208 258	350
727 018 577	15	727 158 511	16	727 208 259	350
727 018 606	14	727 158 512	16	727 208 260	350
727 018 607	14	727 158 513	16	727 208 261	350
727 018 608	14	727 158 514	16	727 208 262	350
727 018 609	14	727 158 515	16	727 208 263	350
727 018 610	14	727 158 516	16	727 208 264	350
727 018 611	14	727 158 517	16	727 208 271	350
727 018 612	14	727 158 519	16	727 208 272	350
727 018 613	14	727 158 520	16	727 208 273	350

Index

Code	Page
727 208 274	350
727 208 288	351
727 208 289	351
727 208 291	351
727 208 301	22
727 208 302	22
727 208 303	22
727 208 304	22
727 208 305	22
727 208 307	22
727 208 308	22
727 208 309	22
727 208 310	22
727 208 311	22
727 208 312	22
727 208 313	22
727 208 314	22
727 208 321	22
727 208 322	22
727 208 323	22
727 208 324	22
727 208 338	22
727 208 339	22
727 208 341	22
727 208 351	21
727 208 352	21
727 208 353	21
727 208 354	21
727 208 355	21
727 208 357	21
727 208 358	21
727 208 359	21
727 208 360	21
727 208 361	21
727 208 362	21
727 208 363	21
727 208 364	21
727 208 365	21
727 208 366	21
727 208 367	21
727 208 368	21
727 208 369	21
727 208 370	21
727 208 371	21
727 208 372	21
727 208 373	21
727 208 374	21
727 208 375	21
727 208 385	21
727 208 386	21
727 208 388	21
727 208 389	21
727 208 391	21
727 208 393	21
727 208 412	20
727 208 413	20
727 208 414	20
727 208 506	20
727 208 507	20
727 208 508	20
727 208 509	20
727 208 510	20
727 208 511	20
727 208 512	20
727 208 513	20
727 208 514	20
727 208 515	20
727 208 516	20

Code	Page
727 208 517	20
727 208 519	20
727 208 520	20
727 208 535	20
727 208 536	20
727 208 540	20
727 208 541	20
727 208 542	20
727 208 543	20
727 208 544	20
727 208 545	20
727 208 546	20
727 208 547	20
727 208 548	20
727 208 549	20
727 208 550	20
727 208 551	20
727 208 552	20
727 208 568	20
727 208 571	20
727 208 572	20
727 208 573	20
727 208 574	20
727 208 575	20
727 208 576	20
727 208 577	20
727 208 581	350
727 208 582	350
727 208 583	350
727 208 584	350
727 208 585	350
727 208 586	350
727 208 587	350
727 208 588	350
727 208 589	350
727 208 590	350
727 208 591	350
727 208 592	350
727 208 593	350
727 208 594	350
727 208 595	350
727 208 596	350
727 208 597	350
727 208 598	350
727 310 006	62
727 310 007	62
727 310 008	62
727 310 009	62
727 310 010	62
727 310 011	62
727 310 036	62
727 310 037	62
727 310 038	62
727 310 039	62
727 310 040	62
727 310 041	62
727 311 012	37
727 311 013	37
727 311 014	37
727 311 015	37
727 311 016	37
727 311 017	37
727 311 018	37
727 311 019	37
727 311 020	37
727 311 021	37
727 311 022	37
727 311 023	37

Code	Page
727 311 042	37
727 311 043	37
727 311 044	37
727 311 045	37
727 311 046	37
727 311 047	37
727 311 048	37
727 311 049	37
727 311 050	37
727 311 051	37
727 311 052	37
727 311 053	37
727 312 072	38
727 312 073	38
727 312 074	38
727 312 075	38
727 312 076	38
727 312 077	38
727 312 078	38
727 312 079	38
727 312 080	38
727 312 081	38
727 312 082	38
727 312 083	38
727 314 000	38
727 314 001	38
727 314 002	38
727 318 006	39
727 318 007	39
727 318 008	39
727 318 009	39
727 318 010	39
727 318 011	39
727 318 036	39
727 318 037	39
727 318 038	39
727 318 039	39
727 318 040	39
727 318 041	39
727 500 106	531
727 500 107	531
727 500 108	305
727 500 109	305
727 500 110	305
727 500 111	305
727 508 506	43
727 508 507	43
727 508 508	43
727 508 509	43
727 508 510	43
727 508 511	43
727 508 512	43
727 508 513	43
727 508 514	43
727 510 155	63
727 510 156	63
727 510 157	63
727 510 158	63
727 510 159	63
727 510 160	63
727 510 161	63
727 510 172	63
727 510 173	63
727 510 174	63
727 510 255	358
727 510 256	358
727 510 257	358
727 510 258	358

Index

Code	Page
727 510 259	358
727 510 260	358
727 510 261	358
727 510 272	358
727 510 273	358
727 510 274	358
727 513 006	63
727 513 007	63
727 513 008	63
727 513 009	63
727 513 010	63
727 513 011	63
727 518 412	40
727 518 413	40
727 518 414	40
727 518 506	40
727 518 507	40
727 518 508	40
727 518 509	40
727 518 510	40
727 518 511	40
727 518 512	40
727 518 513	40
727 518 514	40
727 518 606	353
727 518 607	353
727 518 608	353
727 518 609	353
727 518 610	353
727 518 611	353
727 518 612	353
727 518 613	353
727 518 614	353
727 520 155	63
727 520 156	63
727 520 157	63
727 520 158	63
727 520 159	63
727 520 160	63
727 520 161	63
727 520 172	63
727 520 173	63
727 520 174	63
727 520 255	358
727 520 256	358
727 520 257	358
727 520 258	358
727 520 259	358
727 520 260	358
727 520 261	358
727 520 272	358
727 520 273	358
727 520 274	358
727 528 412	40
727 528 413	40
727 528 414	40
727 528 506	40
727 528 507	40
727 528 508	40
727 528 509	40
727 528 510	40
727 528 511	40
727 528 512	40
727 528 513	40
727 528 514	40
727 528 606	353
727 528 607	353
727 528 608	353

Code	Page
727 528 609	353
727 528 610	353
727 528 611	353
727 528 612	353
727 528 613	353
727 528 614	353
727 530 306	66
727 530 307	66
727 530 308	66
727 530 309	66
727 530 310	66
727 530 311	66
727 530 806	66
727 530 807	66
727 530 808	66
727 530 809	66
727 530 810	66
727 530 811	66
727 600 106	536
727 600 107	536
727 600 108	536
727 600 109	536
727 600 110	536
727 600 111	536
727 608 412	43
727 608 413	43
727 608 414	43
727 608 516	43
727 608 517	43
727 608 518	43
727 608 519	43
727 608 520	43
727 608 521	43
727 648 412	44
727 648 413	44
727 648 414	44
727 665 520	50
727 665 521	50
727 665 522	50
727 665 523	50
727 665 524	50
727 665 525	50
727 665 526	50
727 665 527	50
727 665 528	50
727 665 529	50
727 665 530	50
727 665 531	50
727 665 532	50
727 665 533	50
727 665 534	50
727 665 535	50
727 665 536	50
727 665 539	50
727 665 540	50
727 665 541	50
727 665 542	50
727 665 543	50
727 665 544	50
727 665 545	50
727 665 546	50
727 665 547	50
727 665 548	50
727 665 549	50
727 665 550	50
727 665 551	50
727 665 552	50
727 665 553	50

Code	Page
727 665 554	50
727 665 555	50
727 690 406	536
727 690 407	536
727 690 408	536
727 690 409	536
727 690 410	536
727 690 411	536
727 690 442	428
727 690 443	428
727 700 206	54
727 700 207	54
727 700 208	54
727 700 209	54
727 700 210	54
727 700 211	54
727 700 212	54
727 700 213	72
727 700 214	72
727 700 313	54
727 700 314	54
727 700 315	54
727 700 316	54
727 700 318	54
727 700 319	54
727 700 320	54
727 700 321	54
727 700 322	54
727 700 323	54
727 700 324	54
727 700 325	54
727 700 406	52
727 700 407	52
727 700 408	52
727 700 409	52
727 700 410	52
727 700 411	52
727 700 412	52
727 700 413	52
727 700 414	52
727 700 513	52
727 700 514	52
727 700 515	52
727 700 516	52
727 700 518	52
727 700 521	52
727 700 522	52
727 700 523	52
727 700 524	52
727 700 525	52
727 700 611	51
727 700 612	51
727 700 613	51
727 700 614	51
727 700 615	51
727 700 616	51
727 700 617	51
727 700 618	51
727 700 619	51
727 700 620	51
727 700 621	51
727 700 622	51
727 700 623	51
727 700 624	51
727 700 625	51
727 700 626	51
727 700 627	51
727 700 628	51

Index

Code	Page
727 700 629	51
727 701 206	54
727 701 207	54
727 701 208	54
727 701 209	54
727 701 210	54
727 701 211	54
727 701 212	54
727 701 213	72
727 701 214	72
727 701 313	54
727 701 314	54
727 701 319	54
727 701 320	54
727 701 406	53
727 701 407	53
727 701 408	53
727 701 409	53
727 701 410	53
727 701 411	53
727 701 412	53
727 701 413	53
727 701 414	53
727 701 513	53
727 701 514	53
727 701 521	53
727 701 522	53
727 701 523	53
727 730 106	73
727 730 107	73
727 730 108	73
727 730 109	73
727 730 110	73
727 730 111	73
727 740 106	73
727 740 107	73
727 740 108	73
727 740 109	73
727 740 110	73
727 740 111	73
727 790 206	69
727 790 207	69
727 790 208	69
727 790 209	69
727 790 210	69
727 790 211	69
727 790 212	69
727 790 213	69
727 790 214	69
727 790 257	69
727 790 258	69
727 790 259	69
727 790 260	69
727 790 263	69
727 798 623	46
727 798 624	46
727 798 625	46
727 798 626	46
727 798 627	46
727 798 648	49
727 798 649	49
727 798 650	49
727 798 651	49
727 798 652	49
727 798 706	46
727 798 707	46
727 798 708	46
727 798 709	46

Code	Page
727 798 710	46
727 798 711	46
727 798 712	46
727 798 713	46
727 798 714	46
727 798 715	46
727 798 716	46
727 798 717	46
727 798 718	46
727 798 719	46
727 798 720	46
727 798 721	46
727 798 722	46
727 798 723	46
727 798 724	46
727 798 725	46
727 798 726	46
727 798 727	46
727 798 731	354
727 798 732	354
727 798 733	354
727 798 734	354
727 798 735	354
727 798 736	354
727 798 737	354
727 798 738	354
727 798 739	354
727 798 740	354
727 798 741	354
727 798 742	354
727 798 743	354
727 798 744	354
727 798 745	354
727 798 746	354
727 798 747	354
727 798 748	354
727 798 757	47
727 798 758	47
727 798 759	47
727 798 760	47
727 798 763	47
727 798 785	48
727 798 786	48
727 798 787	48
727 798 788	48
727 798 789	48
727 798 790	48
727 798 791	48
727 798 792	48
727 798 793	48
727 798 794	48
727 798 795	48
727 798 796	48
727 798 797	48
727 798 798	48
727 798 799	48
727 798 800	48
727 798 801	48
727 798 802	48
727 800 009	70
727 800 010	70
727 800 011	70
727 800 012	70
727 800 013	70
727 800 014	70
727 808 009	49
727 808 010	49
727 808 011	49

Code	Page
727 808 012	49
727 808 013	49
727 808 014	49
727 808 016	49
727 808 017	49
727 808 020	49
727 808 022	49
727 808 023	49
727 808 034	49
727 808 035	49
727 808 036	49
727 808 037	49
727 808 038	49
727 808 039	49
727 808 041	49
727 808 042	49
727 808 045	49
727 808 047	49
727 808 048	49
727 808 134	357
727 808 135	357
727 808 136	357
727 808 137	357
727 808 138	357
727 808 139	357
727 808 141	357
727 808 142	357
727 808 145	357
727 808 147	357
727 808 148	357
727 810 106	70
727 810 107	70
727 810 108	70
727 810 109	70
727 810 110	70
727 810 111	70
727 810 112	70
727 810 113	70
727 810 114	70
727 848 506	43
727 848 507	43
727 848 508	43
727 848 509	43
727 848 510	43
727 848 511	43
727 848 512	44
727 848 513	44
727 848 514	44
727 890 405	68
727 890 406	68
727 890 407	68
727 890 408	68
727 890 409	68
727 890 410	68
727 890 411	68
727 890 422	68
727 890 423	68
727 890 424	68
727 900 006	58
727 900 007	58
727 908 464	30
727 908 465	30
727 908 470	30
727 908 471	30
727 908 476	30
727 908 477	30
727 908 537	27
727 908 541	27

Index

Code	Page
727 908 542	27
727 908 546	27
727 908 547	27
727 908 548	27
727 908 552	27
727 908 553	27
727 908 554	27
727 908 558	27
727 908 559	27
727 908 560	27
727 908 564	27
727 908 565	27
727 908 566	27
727 908 570	27
727 908 571	27
727 908 576	27
727 908 577	27
727 908 580	27
727 908 584	27
727 908 585	27
727 908 588	27
727 908 590	27
727 908 592	27
727 908 595	28
727 908 596	28
727 908 597	28
727 908 637	351
727 908 641	351
727 908 642	351
727 908 646	351
727 908 647	351
727 908 648	351
727 908 652	351
727 908 653	351
727 908 654	351
727 908 658	351
727 908 659	351
727 908 660	351
727 908 664	351
727 908 665	351
727 908 666	351
727 908 670	351
727 908 671	351
727 908 676	351
727 908 677	351
727 908 680	351
727 908 684	351
727 908 685	351
727 908 688	351
727 908 690	351
727 908 691	351
727 908 692	351
727 908 693	351
727 908 694	351
727 908 695	351
727 908 696	351
727 908 697	351
727 908 698	351
727 908 699	351
727 908 700	351
727 908 701	351
727 908 702	351
727 908 703	351
727 908 704	351
727 908 705	351
727 908 706	351
727 908 900	30
727 908 901	30

Code	Page
727 908 904	30
727 908 912	30
727 908 916	30
727 908 917	30
727 908 920	30
727 908 922	30
727 908 924	30
727 908 925	30
727 908 926	30
727 908 927	30
727 908 928	30
727 908 929	30
727 908 930	30
727 908 932	30
727 908 933	30
727 908 934	30
727 908 936	30
727 908 937	30
727 908 940	30
727 908 941	30
727 908 942	30
727 908 945	30
727 908 946	30
727 908 947	30
727 908 948	28
727 908 949	30
727 908 950	28
727 908 951	28
727 908 952	351
727 908 953	28
727 908 954	28
727 908 955	351
727 908 956	28
727 908 957	30
727 908 958	30
727 908 959	30
727 908 960	28
727 908 961	28
727 908 962	28
727 908 963	28
727 908 964	28
727 908 965	28
727 908 966	28
727 908 967	30
727 908 971	30
727 908 972	30
727 908 974	27
727 908 975	27
727 908 976	27
727 908 977	27
727 908 978	27
727 908 979	28
727 908 983	28
727 908 984	30
727 908 987	28
727 908 988	30
727 908 989	30
727 908 990	28
727 908 991	28
727 908 992	28
727 908 993	30
727 908 994	31
727 908 995	28
727 908 996	28
727 908 997	28
727 908 998	31
727 908 999	31
727 910 105	57

Code	Page
727 910 106	57
727 910 107	57
727 910 108	57
727 910 109	57
727 910 110	57
727 910 111	57
727 910 112	57
727 910 113	57
727 910 114	57
727 910 205	60
727 910 206	60
727 910 207	60
727 910 208	60
727 910 209	60
727 910 210	60
727 910 211	60
727 910 266	33
727 910 267	33
727 910 268	33
727 910 269	33
727 910 270	33
727 910 271	33
727 910 334	57
727 910 337	57
727 910 338	57
727 910 341	57
727 910 342	57
727 910 346	57
727 910 347	57
727 910 348	57
727 910 352	57
727 910 353	57
727 910 354	57
727 910 355	57
727 910 358	57
727 910 359	57
727 910 360	57
727 910 361	57
727 910 364	57
727 910 370	58
727 910 371	58
727 910 376	58
727 910 433	61
727 910 434	61
727 910 437	61
727 910 441	61
727 910 446	61
727 910 452	61
727 910 505	60
727 910 506	60
727 910 507	60
727 910 508	60
727 910 509	60
727 910 510	60
727 910 511	60
727 910 556	33
727 910 557	33
727 910 558	33
727 910 559	33
727 910 560	33
727 910 561	33
727 910 906	57
727 910 907	57
727 910 908	57
727 910 909	57
727 910 910	57
727 910 911	57
727 910 912	57

Index

Code	Page
727 910 913	57
727 910 914	57
727 913 006	59
727 913 007	59
727 913 008	59
727 913 009	59
727 913 010	59
727 913 011	59
727 913 013	59
727 913 014	59
727 914 266	60
727 914 267	60
727 914 268	60
727 914 269	60
727 914 270	60
727 914 271	60
727 914 356	33
727 914 357	33
727 914 358	33
727 914 359	33
727 914 360	33
727 914 361	33
727 914 555	61
727 914 556	61
727 914 557	61
727 914 558	61
727 914 559	61
727 914 560	61
727 914 561	61
727 914 656	34
727 914 657	34
727 914 658	34
727 914 659	34
727 914 660	34
727 914 661	34
727 960 105	58
727 960 106	58
727 960 107	58
727 960 108	58
727 960 109	58
727 960 110	58
727 960 111	58
727 960 112	58
727 960 113	58
727 960 114	58
727 960 406	61
727 960 407	61
727 960 408	61
727 960 409	61
727 960 410	61
727 960 411	61
727 968 606	34
727 968 607	34
727 968 608	34
727 968 609	34
727 968 610	34
727 968 611	34
727 968 821	32
727 968 822	32
727 968 823	32
727 968 824	32
727 968 825	32
727 968 826	32
727 968 827	32
727 968 846	31
727 968 847	31
727 968 848	31
727 968 849	31

Code	Page
727 968 850	31
727 968 851	31
727 968 852	31
727 968 910	31
727 968 911	31
727 968 912	31
727 968 913	31
727 968 914	31
727 968 915	31
727 968 916	31
727 968 917	31
727 968 918	32
727 968 919	32
727 968 920	32
727 968 931	31
727 968 932	31
727 968 933	31
727 968 934	31
727 968 935	31
727 968 936	31
727 968 937	31
727 968 938	31
727 968 939	31
727 968 940	31
727 968 941	31
727 968 942	31
727 968 943	31
727 968 944	31
727 968 945	31
727 968 981	352
727 968 982	352
727 968 983	352
727 968 984	352
727 968 985	352
727 968 986	352
727 968 987	352
727 968 988	352
727 968 989	352
727 968 990	352
727 968 991	352
727 968 992	352
727 968 993	352
727 968 994	352
727 968 995	352
728 018 606	327
728 018 607	327
728 018 608	327
728 018 609	327
728 018 610	327
728 018 611	327
728 158 506	327
728 158 507	327
728 158 508	327
728 158 509	327
728 158 510	327
728 158 511	327
728 208 506	327
728 208 507	327
728 208 508	327
728 208 509	327
728 208 510	327
728 208 511	327
728 318 006	333
728 318 007	333
728 318 008	333
728 318 009	333
728 318 010	333
728 318 011	333

Code	Page
728 318 036	333
728 318 037	333
728 318 038	333
728 318 039	333
728 318 040	333
728 318 041	333
728 318 106	333
728 318 107	333
728 318 108	333
728 318 109	333
728 318 110	333
728 318 111	333
728 318 136	333
728 318 137	333
728 318 138	333
728 318 139	333
728 318 140	333
728 318 141	333
728 518 526	328
728 518 527	328
728 518 528	328
728 518 529	328
728 518 530	328
728 518 531	328
728 528 526	328
728 528 527	328
728 528 528	328
728 528 529	328
728 528 530	328
728 528 531	328
728 598 006	330
728 598 008	330
728 598 009	330
728 598 010	330
728 598 014	330
728 598 016	330
728 598 018	330
728 598 056	330
728 598 057	330
728 598 059	330
728 598 062	330
728 598 065	330
728 598 067	330
728 598 207	332
728 598 209	332
728 598 213	332
728 598 215	332
728 598 217	332
728 598 219	332
728 598 259	331
728 598 262	331
728 598 265	331
728 598 267	331
728 598 269	331
728 598 309	331
728 598 312	331
728 598 315	331
728 598 317	331
728 598 319	331
728 598 357	331
728 598 359	331
728 598 362	331
728 598 365	331
728 598 367	331
728 598 369	331
728 598 406	332
728 598 408	332
728 598 410	332

Index

Code	Page
728 598 414	332
728 598 416	332
728 598 418	332
728 598 516	332
728 598 518	332
728 598 520	332
728 648 526	328
728 648 527	328
728 648 528	328
728 648 529	328
728 648 530	328
728 648 531	328
728 798 657	334
728 798 658	334
728 798 659	334
728 798 660	334
728 798 706	334
728 798 707	334
728 798 708	334
728 798 709	334
728 798 710	334
728 798 711	334
728 798 787	334
728 798 788	334
728 798 789	334
728 908 537	328
728 908 541	328
728 908 542	328
728 908 546	328
728 908 547	328
728 908 548	328
728 908 552	328
728 908 553	328
728 908 554	328
728 908 558	328
728 908 559	328
728 908 560	328
728 914 056	329
728 914 057	329
728 914 058	329
728 914 059	329
728 914 060	329
728 914 061	329
728 914 106	330
728 914 107	330
728 914 108	330
728 914 109	330
728 914 110	330
728 914 111	330
728 918 056	329
728 918 057	329
728 918 058	329
728 918 059	329
728 918 060	329
728 918 061	329
728 918 106	329
728 918 107	329
728 918 108	329
728 918 109	329
728 918 110	329
728 918 111	329
729 601 106	531
729 601 107	531
729 601 108	531
729 601 109	531
729 601 110	531
729 601 111	531
729 690 012	511

Code	Page
729 690 013	511
729 690 014	511
729 790 106	533
729 790 107	533
729 790 108	533
729 790 109	533
729 790 110	533
729 790 111	533
729 800 106	531
729 800 107	531
729 800 108	305
729 800 109	305
729 800 110	305
729 800 111	305
729 800 162	511
729 800 163	511
729 800 164	511
729 890 406	531
729 890 407	531
729 890 408	304
729 890 409	304
729 890 410	304
729 890 411	304
733 100 106	390
733 100 107	390
733 100 108	390
733 100 109	390
733 100 110	390
733 100 111	390
733 100 112	390
733 100 113	390
733 100 114	390
733 100 206	392
733 100 207	392
733 100 208	392
733 100 209	392
733 150 106	390
733 150 107	390
733 150 108	390
733 150 109	390
733 150 110	390
733 150 111	390
733 150 112	390
733 150 113	390
733 150 114	390
733 200 106	390
733 200 107	390
733 200 108	390
733 200 109	390
733 200 110	390
733 200 111	390
733 200 112	390
733 200 113	390
733 200 114	390
733 580 106	394
733 580 107	394
733 580 108	394
733 580 109	394
733 580 110	394
733 580 111	394
733 580 206	394
733 580 207	394
733 580 208	394
733 580 209	394
733 580 210	394
733 580 211	394
733 580 706	394
733 580 707	394

Code	Page
733 580 708	394
733 580 709	394
733 580 710	394
733 580 711	394
733 690 406	428
733 690 407	428
733 690 408	428
733 690 409	428
733 690 410	428
733 690 411	428
733 800 009	398
733 800 010	398
733 800 011	398
733 800 012	398
733 800 013	398
733 800 014	398
733 808 009	434
733 808 010	434
733 808 011	434
733 808 012	434
733 808 013	434
733 808 014	434
733 808 016	434
733 808 017	434
733 808 020	434
733 808 022	434
733 808 023	434
733 808 034	434
733 808 035	434
733 808 036	434
733 808 037	434
733 808 038	434
733 808 039	434
733 808 041	434
733 808 042	434
733 808 045	434
733 808 047	434
733 808 048	434
733 810 106	396
733 810 107	396
733 810 108	396
733 810 109	396
733 810 110	396
733 810 111	396
733 810 112	396
733 810 113	396
733 810 114	396
733 900 006	388
733 900 007	388
733 910 106	391
733 910 107	391
733 910 108	391
733 910 109	391
733 910 110	391
733 910 111	391
733 910 112	391
733 910 113	391
733 910 114	391
733 910 206	392
733 910 207	392
733 910 208	392
733 910 209	392
733 910 210	392
733 910 211	392
733 910 337	391
733 910 341	391
733 910 346	391
733 910 347	391

Index

Code	Page	Code	Page	Code	Page
733 910 348	391	745 440 711	440	748 400 332	441
733 910 352	391	745 440 712	440	748 400 333	441
733 910 353	391	745 440 713	440	748 410 001	73
733 910 358	391	745 440 714	440	748 410 002	73
733 910 359	391	745 440 715	440	748 410 003	73
733 910 360	391	745 440 716	440	748 410 004	44
733 910 361	391	745 440 717	440	748 410 005	44
733 910 362	391	745 440 719	440	748 410 006	44
733 910 364	391	745 440 720	440	748 410 007	44
733 910 370	391	745 440 721	440	748 410 008	44
733 910 371	391	745 440 722	441	748 410 009	44
733 910 376	391	745 440 723	441	748 410 010	44
733 910 434	392	745 440 724	441	748 410 011	44
733 910 437	392	745 440 725	441	748 410 012	73
733 910 441	392	745 440 726	441	748 410 013	44
733 910 446	392	745 440 727	441	748 410 014	44
733 910 452	392	745 440 728	441	748 410 015	44
733 960 106	391	745 440 729	441	748 410 016	44
733 960 107	391	745 500 012	530	748 410 023	492
733 960 108	391	745 500 013	530	748 410 025	609
733 960 109	391	745 500 014	530	748 410 027	499
733 960 110	391	745 500 015	530	748 410 038	537
733 960 111	391	745 500 016	530	748 410 042	499
733 960 112	391	745 500 017	530	748 410 044	537
733 960 113	391	747 502 012	530	748 410 052	537
733 960 114	391	747 502 013	530	748 410 059	491
734 600 106	66	747 502 014	530	748 410 062	491
734 600 107	66	747 502 015	530	748 410 099	510
734 600 108	66	747 502 016	530	748 410 103	499
734 600 109	66	747 502 017	530	748 410 106	491
734 600 110	66	747 502 032	530	748 410 112	510
734 600 111	66	747 502 033	530	748 410 116	499
735 600 106	531	747 502 034	530	748 410 119	492
735 600 107	531	747 502 035	530	748 410 123	524
735 600 108	305	747 502 036	530	748 410 134	537
735 600 109	305	747 502 037	530	748 410 135	537
735 600 110	305	747 503 012	530	748 410 137	524
735 600 111	305	747 503 013	530	748 410 138	524
735 608 606	531	747 503 014	530	748 410 139	524
735 608 607	531	747 503 015	530	748 410 140	609
735 608 608	305	747 503 016	530	748 410 151	491
735 608 609	305	747 503 017	530	748 410 152	609
735 608 610	305	748 400 006	533	748 410 171	609
735 608 611	305	748 400 007	533	748 410 195	537
735 690 406	531	748 400 008	533	748 410 212	542
735 690 407	531	748 400 009	533	748 410 231	491
735 690 408	304	748 400 010	533	748 410 248	44
735 690 409	304	748 400 011	533	748 410 254	492
735 690 410	304	748 400 305	439	748 410 318	518
735 690 411	304	748 400 306	439	748 410 319	518
735 740 106	502	748 400 307	439	748 410 320	518
735 740 107	502	748 400 308	439	748 410 321	518
735 740 108	502	748 400 309	439	748 410 322	518
735 740 109	502	748 400 310	439	748 436 001	556
735 740 110	502	748 400 311	439	748 436 002	556
735 740 111	502	748 400 312	439	748 436 003	556
735 790 206	533	748 400 313	439	748 436 004	556
735 790 207	533	748 400 314	439	748 436 005	556
735 790 208	533	748 400 315	439	748 436 006	556
735 790 209	533	748 400 316	439	748 436 007	556
735 790 210	533	748 400 317	439	748 436 008	556
735 790 211	533	748 400 319	439	748 436 009	556
745 410 107	542	748 400 320	439	748 440 018	520
745 440 706	440	748 400 321	439	748 440 019	520
745 440 707	440	748 400 322	439	748 440 020	520
745 440 708	440	748 400 323	439	748 440 021	520
745 440 709	440	748 400 330	441	748 440 022	520
745 440 710	440	748 400 331	441	748 440 705	55

Index

Code	Page	Code	Page	Code	Page
748 440 706	55	749 410 023	492	749 440 721	55
748 440 707	55	749 410 025	609	749 440 722	55
748 440 708	55	749 410 027	499	749 440 723	55
748 440 709	55	749 410 038	537	749 440 724	55
748 440 710	55	749 410 042	499	749 440 725	55
748 440 711	55	749 410 044	537	749 440 726	55
748 440 712	55	749 410 052	537	749 440 727	55
748 440 713	55	749 410 054	532	749 440 728	55
748 440 714	55	749 410 059	491	749 440 729	55
748 440 715	55	749 410 062	491	749 441 706	357
748 440 716	55	749 410 099	510	749 441 707	357
748 440 717	55	749 410 103	499	749 441 708	357
748 440 719	55	749 410 106	491	749 441 709	357
748 440 720	55	749 410 112	510	749 441 710	357
748 440 721	55	749 410 116	499	749 441 711	357
748 440 722	55	749 410 119	492	749 441 712	357
748 440 723	55	749 410 120	532	749 441 713	357
748 440 724	55	749 410 134	537	749 441 714	357
748 440 725	55	749 410 135	537	749 441 715	357
748 440 726	55	749 410 140	609	749 441 716	357
748 440 727	55	749 410 151	491	749 441 717	357
748 440 728	55	749 410 152	609	749 441 719	357
748 440 729	55	749 410 171	609	749 441 720	357
748 441 706	357	749 410 172	532	749 441 721	357
748 441 707	357	749 410 195	537	749 441 722	357
748 441 708	357	749 410 231	491	749 441 723	357
748 441 709	357	749 410 248	44	749 500 012	530
748 441 710	357	749 410 254	492	749 500 013	530
748 441 711	357	749 410 318	518	749 500 014	530
748 441 712	357	749 410 319	518	749 500 015	530
748 441 713	357	749 410 320	518	749 500 016	530
748 441 714	357	749 410 321	518	749 500 017	530
748 441 715	357	749 410 322	518	753 000 813	462
748 441 716	357	749 411 005	532	753 000 814	462
748 441 717	357	749 411 006	532	753 000 815	462
748 441 719	357	749 411 054	532	753 000 816	462
748 441 720	357	749 411 062	532	753 000 817	462
748 441 721	357	749 411 120	532	753 000 818	462
748 441 722	357	749 411 172	532	753 000 819	462
748 441 723	357	749 436 001	556	753 000 820	462
748 500 012	530	749 436 002	556	753 000 821	462
748 500 013	530	749 436 003	556	753 000 822	462
748 500 014	530	749 436 004	556	753 000 823	462
748 500 015	530	749 436 005	556	753 000 824	462
748 500 016	530	749 436 006	556	753 000 825	462
748 500 017	530	749 436 007	556	753 000 826	462
749 400 006	533	749 436 008	556	753 000 827	462
749 400 007	533	749 436 009	556	753 000 828	462
749 400 008	533	749 440 028	520	753 000 829	462
749 400 009	533	749 440 029	520	753 000 830	462
749 400 010	533	749 440 030	520	753 000 831	462
749 400 011	533	749 440 031	520	753 001 008	462
749 410 001	73	749 440 032	520	753 001 009	462
749 410 002	73	749 440 705	55	753 001 010	462
749 410 003	73	749 440 706	55	753 001 011	462
749 410 004	44	749 440 707	55	753 001 012	462
749 410 005	44	749 440 708	55	753 001 013	462
749 410 006	44	749 440 709	55	753 001 014	462
749 410 007	44	749 440 710	55	753 001 015	462
749 410 008	44	749 440 711	55	753 001 016	462
749 410 009	44	749 440 712	55	753 001 017	462
749 410 010	44	749 440 713	55	753 001 018	462
749 410 011	44	749 440 714	55	753 001 019	462
749 410 012	73	749 440 715	55	753 001 020	462
749 410 013	44	749 440 716	55	753 001 021	462
749 410 014	44	749 440 717	55	753 001 022	462
749 410 015	44	749 440 719	55	753 001 023	462
749 410 016	44	749 440 720	55	753 001 024	462

Index

Code	Page
753 001 025	462
753 001 026	462
753 001 027	462
753 001 028	462
753 001 029	462
753 001 030	462
753 001 031	462
753 002 001	463
753 002 002	463
753 002 003	463
753 002 004	463
753 003 001	466
753 003 002	466
753 003 003	466
753 003 004	466
753 018 521	402
753 018 522	402
753 018 523	402
753 018 590	402
753 018 591	402
753 018 592	402
753 018 593	402
753 018 594	402
753 018 595	402
753 018 621	402
753 018 622	402
753 018 623	402
753 018 635	402
753 018 636	402
753 018 690	402
753 018 691	402
753 018 692	402
753 018 693	402
753 018 694	402
753 018 695	402
753 018 706	402
753 018 707	402
753 018 708	402
753 018 709	402
753 018 710	402
753 018 711	402
753 018 712	402
753 018 713	402
753 018 714	402
753 018 737	402
753 018 738	402
753 018 739	402
753 020 824	402
753 020 825	402
753 020 826	402
753 020 827	402
753 021 024	402
753 021 025	402
753 021 026	402
753 021 027	402
753 050 813	466
753 050 814	466
753 050 815	466
753 050 816	466
753 050 817	466
753 050 818	466
753 050 819	466
753 050 820	466
753 050 821	466
753 050 822	466
753 050 823	466
753 050 824	466
753 050 825	466

Code	Page
753 050 826	466
753 050 827	466
753 050 828	466
753 050 829	466
753 051 008	465
753 051 009	465
753 051 010	465
753 051 011	465
753 051 012	465
753 051 013	465
753 051 014	465
753 051 015	465
753 051 016	465
753 051 017	465
753 051 018	465
753 051 019	465
753 051 020	465
753 051 021	465
753 051 022	465
753 051 023	465
753 051 024	465
753 051 025	465
753 051 026	465
753 051 027	465
753 051 028	465
753 051 029	465
753 060 813	468
753 060 814	468
753 060 815	468
753 060 816	468
753 060 817	468
753 060 818	468
753 060 819	468
753 060 820	468
753 060 821	468
753 060 822	468
753 060 823	468
753 060 824	468
753 060 825	468
753 060 826	468
753 060 827	468
753 060 828	468
753 060 829	468
753 061 008	468
753 061 009	468
753 061 010	468
753 061 011	468
753 061 012	468
753 061 013	468
753 061 014	468
753 061 015	468
753 061 016	468
753 061 017	468
753 061 018	468
753 061 019	468
753 061 020	468
753 061 021	468
753 061 022	468
753 061 023	468
753 061 024	468
753 061 025	468
753 061 026	468
753 061 027	468
753 061 028	468
753 061 029	468
753 070 813	464
753 070 814	464
753 070 815	464

Code	Page
753 070 816	464
753 070 817	464
753 070 818	464
753 070 819	464
753 070 820	464
753 070 821	464
753 070 822	464
753 070 823	464
753 070 824	464
753 070 825	464
753 070 826	464
753 070 827	464
753 070 828	464
753 070 829	464
753 071 008	463
753 071 009	463
753 071 010	463
753 071 011	463
753 071 012	463
753 071 013	463
753 071 014	463
753 071 015	463
753 071 016	463
753 071 017	463
753 071 018	463
753 071 019	463
753 071 020	463
753 071 021	463
753 071 022	463
753 071 023	463
753 071 024	463
753 071 025	463
753 071 026	463
753 071 027	463
753 071 028	463
753 071 029	463
753 080 813	469
753 080 814	469
753 080 815	469
753 080 816	469
753 080 817	469
753 080 818	469
753 080 819	469
753 080 820	469
753 080 821	469
753 080 822	469
753 080 823	469
753 080 824	469
753 080 825	469
753 080 826	469
753 080 827	469
753 080 828	469
753 080 829	469
753 081 008	469
753 081 009	469
753 081 010	469
753 081 011	469
753 081 012	469
753 081 013	469
753 081 014	469
753 081 015	469
753 081 016	469
753 081 017	469
753 081 018	469
753 081 019	469
753 081 020	469
753 081 021	469
753 081 022	469

Index

Code	Page
753 081 023	469
753 081 024	469
753 081 025	469
753 081 026	469
753 081 027	469
753 081 028	469
753 081 029	469
753 090 813	471
753 090 814	471
753 090 815	471
753 090 816	471
753 090 817	471
753 090 818	471
753 090 819	471
753 090 820	471
753 090 821	471
753 090 822	471
753 090 823	471
753 090 824	471
753 090 825	471
753 090 826	471
753 090 827	471
753 090 828	471
753 090 829	471
753 091 008	471
753 091 009	471
753 091 010	471
753 091 011	471
753 091 012	471
753 091 013	471
753 091 014	471
753 091 015	471
753 091 016	471
753 091 017	471
753 091 018	471
753 091 019	471
753 091 020	471
753 091 021	471
753 091 022	471
753 091 023	471
753 091 024	471
753 091 025	471
753 091 026	471
753 091 027	471
753 091 028	471
753 091 029	471
753 100 813	461
753 100 814	461
753 100 815	461
753 100 816	461
753 100 817	461
753 100 818	461
753 100 819	461
753 100 820	461
753 100 821	461
753 100 822	461
753 100 823	461
753 100 922	461
753 100 923	461
753 101 001	461
753 101 006	461
753 101 007	461
753 101 008	461
753 101 009	461
753 101 010	461
753 101 011	461
753 101 012	461
753 101 013	461

Code	Page
753 101 014	461
753 101 015	461
753 101 016	461
753 101 017	461
753 101 018	461
753 101 019	461
753 101 020	461
753 101 606	444
753 101 607	444
753 101 608	444
753 101 609	444
753 101 610	444
753 101 611	444
753 101 612	444
753 101 813	444
753 101 814	444
753 101 815	444
753 101 817	444
753 101 818	444
753 101 819	444
753 101 820	444
753 101 821	444
753 108 606	403
753 108 607	403
753 108 608	403
753 108 609	403
753 108 610	403
753 108 611	403
753 120 813	467
753 120 814	467
753 120 815	467
753 120 816	467
753 120 817	467
753 120 818	467
753 120 819	467
753 120 820	467
753 120 821	467
753 120 822	467
753 120 823	467
753 120 908	467
753 120 909	467
753 120 910	467
753 120 911	467
753 120 912	467
753 120 913	467
753 120 914	467
753 120 915	467
753 120 916	467
753 120 917	467
753 120 918	467
753 120 919	467
753 120 920	467
753 120 921	467
753 120 922	467
753 120 923	467
753 140 813	470
753 140 814	470
753 140 815	470
753 140 816	470
753 140 817	470
753 140 818	470
753 140 819	470
753 140 820	470
753 140 821	470
753 140 822	470
753 140 823	470
753 141 008	470
753 141 009	470

Code	Page
753 141 010	470
753 141 011	470
753 141 012	470
753 141 013	470
753 141 014	470
753 141 015	470
753 141 016	470
753 141 017	470
753 141 018	470
753 141 019	470
753 141 020	470
753 141 021	470
753 141 022	470
753 141 023	470
753 150 813	465
753 150 814	465
753 150 815	465
753 150 816	465
753 150 817	465
753 150 818	465
753 150 819	465
753 150 820	465
753 150 821	465
753 150 822	465
753 150 823	465
753 150 922	464
753 150 923	464
753 151 006	464
753 151 007	464
753 151 008	464
753 151 009	464
753 151 010	464
753 151 011	464
753 151 012	464
753 151 013	464
753 151 014	464
753 151 015	464
753 151 016	464
753 151 017	464
753 151 018	464
753 151 019	464
753 151 020	464
753 151 021	464
753 151 609	445
753 151 610	445
753 151 611	445
753 151 813	445
753 151 814	445
753 151 815	445
753 151 817	445
753 151 818	445
753 151 819	445
753 151 820	445
753 151 821	445
753 158 412	403
753 158 413	403
753 158 414	403
753 158 535	403
753 158 536	403
753 158 540	403
753 158 541	403
753 158 542	403
753 158 544	403
753 158 545	403
753 158 606	403
753 158 607	403
753 158 608	403
753 158 609	403

Index

Code	Page
753 158 610	403
753 158 611	403
753 158 612	403
753 158 613	403
753 158 614	403
753 158 615	403
753 158 616	403
753 158 617	403
753 158 619	403
753 158 620	403
753 200 801	478
753 200 802	475
753 200 803	475
753 200 804	475
753 200 805	475
753 200 806	475
753 200 807	475
753 200 808	475
753 200 809	475
753 200 810	478
753 200 811	478
753 200 812	478
753 200 813	475
753 200 814	475
753 200 815	475
753 200 816	475
753 200 817	475
753 200 818	475
753 200 819	475
753 200 820	475
753 200 821	475
753 200 822	478
753 200 823	478
753 200 824	478
753 200 825	478
753 200 826	478
753 200 827	478
753 200 828	477
753 200 829	477
753 200 830	477
753 200 831	477
753 200 832	477
753 200 833	477
753 200 834	477
753 200 835	477
753 200 836	477
753 200 837	477
753 200 838	477
753 200 839	477
753 200 840	477
753 200 841	477
753 200 842	477
753 200 843	477
753 200 844	477
753 200 845	478
753 200 846	478
753 200 847	478
753 200 848	478
753 200 849	478
753 200 850	478
753 200 851	477
753 200 852	477
753 200 853	477
753 200 854	477
753 200 855	478
753 200 856	478
753 200 857	478
753 200 858	478

Code	Page
753 200 859	478
753 200 860	478
753 200 861	478
753 200 862	478
753 200 863	478
753 200 864	478
753 200 865	478
753 200 866	478
753 200 867	478
753 200 868	478
753 200 869	478
753 200 870	478
753 200 902	475
753 200 903	475
753 200 904	475
753 200 905	475
753 200 906	475
753 200 907	475
753 200 908	475
753 200 909	475
753 201 001	475
753 201 002	477
753 201 003	477
753 201 004	477
753 201 005	477
753 201 006	475
753 201 007	475
753 201 008	475
753 201 009	475
753 201 010	475
753 201 011	475
753 201 012	475
753 201 013	475
753 201 014	475
753 201 015	475
753 201 016	475
753 201 017	475
753 201 018	475
753 201 019	475
753 201 020	475
753 201 027	476
753 201 028	476
753 201 029	476
753 201 030	476
753 201 031	476
753 201 032	476
753 201 033	476
753 201 034	476
753 201 035	476
753 201 036	476
753 201 037	476
753 201 038	476
753 201 039	476
753 201 040	476
753 201 041	476
753 201 042	476
753 201 043	476
753 201 044	476
753 201 045	476
753 201 046	476
753 201 047	476
753 201 048	476
753 201 049	476
753 201 050	476
753 201 051	476
753 201 052	476
753 201 053	476
753 201 054	476

Code	Page
753 201 069	477
753 201 070	477
753 201 072	477
753 201 073	476
753 201 074	476
753 201 075	476
753 201 076	476
753 201 077	477
753 201 078	476
753 201 079	476
753 201 080	477
753 201 081	477
753 201 082	477
753 201 084	477
753 201 085	477
753 201 086	477
753 201 087	477
753 201 089	477
753 201 090	477
753 201 091	477
753 201 092	477
753 201 093	477
753 201 094	477
753 201 095	477
753 201 096	477
753 201 097	477
753 201 098	478
753 201 099	478
753 201 100	478
753 201 101	478
753 201 102	478
753 201 103	478
753 201 104	478
753 201 105	478
753 201 106	478
753 201 107	478
753 201 108	478
753 201 109	478
753 201 110	478
753 201 111	478
753 201 112	478
753 201 113	478
753 201 114	478
753 201 115	478
753 201 116	477
753 201 120	475
753 201 121	475
753 201 606	447
753 201 607	447
753 201 608	447
753 201 609	447
753 201 610	447
753 201 611	447
753 201 613	447
753 201 614	447
753 201 615	448
753 201 617	448
753 201 618	448
753 201 813	446
753 201 814	446
753 201 815	446
753 201 817	446
753 201 818	446
753 201 819	446
753 201 820	446
753 201 821	446
753 201 827	477
753 201 873	477

Index

Code	Page	Code	Page	Code	Page
753 201 874	477	753 208 609	404	753 312 023	419
753 201 875	477	753 208 610	404	753 312 024	419
753 201 876	477	753 208 611	404	753 312 025	419
753 201 878	477	753 208 612	404	753 314 000	418
753 201 879	477	753 208 613	404	753 314 001	418
753 201 920	475	753 208 614	404	753 314 002	418
753 201 921	475	753 208 615	404	753 318 006	418
753 202 810	476	753 208 616	404	753 318 007	418
753 202 811	476	753 208 617	404	753 318 008	418
753 202 812	476	753 208 619	404	753 318 009	418
753 202 813	476	753 208 620	404	753 318 010	418
753 208 301	407	753 208 668	404	753 318 011	418
753 208 302	407	753 208 671	404	753 318 036	418
753 208 303	407	753 208 672	404	753 318 037	418
753 208 304	407	753 208 673	404	753 318 038	418
753 208 305	407	753 208 832	405	753 318 039	418
753 208 307	407	753 211 028	404	753 318 040	418
753 208 308	407	753 211 029	404	753 318 041	418
753 208 309	407	753 211 030	404	753 508 606	427
753 208 310	407	753 211 031	404	753 508 607	427
753 208 311	407	753 211 037	447	753 508 608	427
753 208 312	407	753 211 039	447	753 508 609	427
753 208 313	407	753 211 040	447	753 508 610	427
753 208 314	407	753 211 059	447	753 508 611	427
753 208 321	407	753 211 060	447	753 508 616	427
753 208 322	407	753 211 063	447	753 508 617	427
753 208 323	407	753 211 069	447	753 508 618	427
753 208 324	407	753 211 070	447	753 508 619	427
753 208 338	407	753 211 073	447	753 508 620	427
753 208 339	407	753 211 080	447	753 508 621	427
753 208 341	407	753 211 083	447	753 518 412	424
753 208 351	406	753 211 606	446	753 518 413	424
753 208 352	406	753 211 607	446	753 518 414	424
753 208 353	406	753 211 608	446	753 518 606	424
753 208 354	406	753 211 609	446	753 518 607	424
753 208 355	406	753 211 610	446	753 518 608	424
753 208 357	406	753 211 611	446	753 518 609	424
753 208 358	406	753 211 612	446	753 518 610	424
753 208 359	406	753 220 824	405	753 518 611	424
753 208 360	406	753 220 825	405	753 518 612	424
753 208 361	406	753 220 826	405	753 518 613	424
753 208 362	406	753 220 827	405	753 518 614	424
753 208 363	406	753 220 831	405	753 528 412	424
753 208 364	406	753 220 833	405	753 528 413	424
753 208 371	406	753 220 834	405	753 528 414	424
753 208 372	406	753 221 024	404	753 528 606	424
753 208 373	406	753 221 025	404	753 528 607	424
753 208 374	406	753 221 026	404	753 528 608	424
753 208 388	406	753 221 027	404	753 528 609	424
753 208 389	406	753 221 031	406	753 528 610	424
753 208 391	406	753 221 032	406	753 528 611	424
753 208 412	405	753 251 011	479	753 528 612	424
753 208 413	405	753 251 012	479	753 528 613	424
753 208 414	405	753 251 013	479	753 528 614	424
753 208 535	405	753 251 014	479	753 608 412	427
753 208 536	405	753 251 063	479	753 608 413	427
753 208 540	405	753 251 064	479	753 608 414	427
753 208 541	405	753 312 012	419	753 608 608	305
753 208 542	405	753 312 013	419	753 608 609	305
753 208 543	405	753 312 014	419	753 608 610	305
753 208 544	405	753 312 015	419	753 608 611	305
753 208 545	405	753 312 016	419	753 608 612	427
753 208 546	405	753 312 017	419	753 608 613	427
753 208 547	405	753 312 018	419	753 608 614	427
753 208 548	405	753 312 019	419	753 648 412	428
753 208 606	404	753 312 020	419	753 648 413	428
753 208 607	404	753 312 021	419	753 648 414	428
753 208 608	404	753 312 022	419	753 648 606	427

Index

Code	Page
753 648 607	427
753 648 608	427
753 648 609	427
753 648 610	427
753 648 611	427
753 648 612	427
753 648 613	427
753 648 614	427
753 665 558	434
753 665 559	434
753 665 560	434
753 665 561	434
753 665 562	434
753 665 563	434
753 665 564	434
753 665 565	434
753 665 566	434
753 665 567	434
753 665 568	434
753 665 569	434
753 665 570	434
753 665 571	434
753 665 572	435
753 665 573	435
753 665 574	435
753 665 575	435
753 665 576	435
753 665 577	435
753 665 578	435
753 665 579	435
753 665 580	435
753 665 581	435
753 665 582	435
753 665 583	435
753 665 584	435
753 665 585	435
753 665 586	435
753 665 587	435
753 665 588	435
753 665 589	435
753 665 590	435
753 665 591	435
753 665 592	435
753 665 593	435
753 665 594	435
753 665 595	435
753 700 611	397
753 700 612	397
753 700 613	397
753 700 614	397
753 700 615	397
753 700 616	397
753 700 617	397
753 700 618	397
753 700 619	397
753 700 620	397
753 700 621	397
753 700 622	397
753 700 623	397
753 700 624	397
753 700 625	397
753 700 626	397
753 700 627	397
753 700 628	397
753 700 629	397
753 790 206	396
753 790 207	396
753 790 208	396

Code	Page
753 790 209	396
753 790 210	396
753 790 211	396
753 790 212	396
753 790 213	396
753 790 214	396
753 798 723	431
753 798 724	431
753 798 725	431
753 798 726	431
753 798 727	431
753 798 728	431
753 798 729	431
753 798 730	431
753 798 731	431
753 798 748	432
753 798 749	432
753 798 750	432
753 798 751	432
753 798 752	432
753 798 753	432
753 798 754	432
753 798 755	432
753 798 756	432
753 798 757	432
753 798 758	432
753 798 759	432
753 798 826	432
753 798 827	432
753 798 828	432
753 798 829	432
753 798 830	432
753 798 831	432
753 798 832	432
753 798 833	432
753 798 834	432
753 798 835	432
753 798 836	432
753 798 851	433
753 798 852	433
753 798 853	433
753 798 854	433
753 798 855	433
753 798 856	433
753 798 857	433
753 798 858	433
753 798 859	433
753 798 860	433
753 798 861	433
753 798 862	433
753 798 863	433
753 800 006	429
753 800 007	429
753 800 008	429
753 800 009	429
753 800 010	429
753 800 011	429
753 800 012	429
753 800 013	429
753 800 014	429
753 800 015	429
753 800 016	429
753 800 017	429
753 800 018	429
753 800 019	429
753 800 020	429
753 800 021	429
753 800 022	429

Code	Page
753 800 023	429
753 800 024	429
753 800 025	429
753 800 026	429
753 800 027	429
753 800 028	429
753 800 029	429
753 800 030	429
753 800 033	429
753 800 057	430
753 800 058	430
753 800 059	430
753 800 060	430
753 800 063	430
753 800 085	430
753 800 086	430
753 800 087	430
753 800 088	430
753 800 089	430
753 800 090	430
753 800 091	430
753 800 092	430
753 800 093	430
753 800 094	430
753 800 095	431
753 800 096	431
753 800 097	431
753 800 098	431
753 800 099	431
753 800 100	431
753 800 101	431
753 800 102	431
753 800 103	431
753 800 104	431
753 800 105	431
753 800 106	431
753 800 107	431
753 800 108	431
753 900 001	413
753 900 002	413
753 900 004	413
753 900 007	413
753 900 011	413
753 900 012	413
753 900 013	413
753 900 014	413
753 900 015	413
753 900 016	413
753 900 017	413
753 900 018	413
753 900 019	413
753 900 020	413
753 900 021	413
753 900 022	413
753 900 023	413
753 900 024	413
753 900 025	413
753 900 026	413
753 900 027	413
753 900 035	413
753 900 036	413
753 900 037	413
753 900 800	482
753 900 801	482
753 900 802	482
753 900 803	482
753 900 804	482
753 900 805	482

Index

Code	Page
753 900 806	482
753 900 807	482
753 900 808	482
753 900 809	482
753 900 810	482
753 900 811	482
753 900 812	482
753 900 813	482
753 900 814	482
753 900 815	482
753 900 816	482
753 900 817	482
753 900 818	482
753 900 819	482
753 900 820	482
753 900 821	482
753 900 822	482
753 900 823	482
753 900 824	482
753 900 825	482
753 900 826	482
753 900 827	482
753 900 828	482
753 900 829	482
753 900 831	482
753 900 832	482
753 900 833	482
753 900 834	482
753 900 835	483
753 900 836	483
753 900 837	483
753 900 838	483
753 900 839	483
753 900 840	483
753 900 841	483
753 900 842	483
753 900 843	483
753 900 844	483
753 900 866	482
753 900 867	482
753 900 868	482
753 900 870	482
753 900 872	482
753 900 873	482
753 900 874	482
753 900 875	482
753 900 876	482
753 900 877	482
753 900 880	482
753 900 881	482
753 900 882	482
753 900 884	482
753 900 885	482
753 900 886	482
753 900 887	482
753 900 888	482
753 900 889	482
753 900 890	482
753 900 891	482
753 900 892	482
753 900 893	482
753 900 894	482
753 900 895	482
753 900 896	482
753 900 898	482
753 900 899	482
753 901 000	480
753 901 001	480

Code	Page
753 901 002	480
753 901 003	480
753 901 004	480
753 901 005	480
753 901 012	480
753 901 013	480
753 901 014	480
753 901 015	480
753 901 016	480
753 901 017	480
753 901 018	481
753 901 019	481
753 901 020	481
753 901 022	481
753 901 024	481
753 901 025	481
753 901 026	481
753 901 027	481
753 901 029	481
753 901 030	481
753 901 032	480
753 901 033	480
753 901 034	480
753 901 038	480
753 901 039	481
753 901 040	481
753 901 041	480
753 901 042	480
753 901 043	481
753 901 044	481
753 901 045	481
753 901 046	480
753 901 047	480
753 901 048	480
753 901 049	481
753 901 050	481
753 901 052	480
753 901 053	480
753 901 054	480
753 901 055	480
753 901 058	480
753 901 059	480
753 901 060	480
753 901 063	480
753 901 064	480
753 901 065	480
753 901 066	480
753 901 067	480
753 901 068	480
753 901 070	480
753 901 071	480
753 901 072	480
753 901 073	480
753 901 074	480
753 901 075	480
753 901 076	480
753 901 077	480
753 901 078	480
753 901 080	480
753 901 081	480
753 901 082	480
753 901 083	480
753 901 084	480
753 901 085	480
753 901 086	480
753 901 087	480
753 901 088	480
753 901 089	480

Code	Page
753 901 090	480
753 901 091	480
753 901 092	480
753 901 094	480
753 901 095	480
753 901 096	480
753 901 097	480
753 901 098	480
753 901 099	480
753 901 639	448
753 901 640	448
753 901 641	448
753 901 644	448
753 901 645	448
753 901 646	448
753 901 651	448
753 901 652	448
753 901 656	448
753 901 657	448
753 901 658	448
753 901 831	448
753 901 833	448
753 901 834	448
753 901 835	448
753 901 836	448
753 901 837	448
753 901 838	448
753 901 840	448
753 901 841	448
753 902 801	414
753 902 802	414
753 902 804	414
753 902 807	414
753 902 811	414
753 902 812	414
753 902 813	414
753 902 814	414
753 902 815	414
753 902 816	414
753 902 817	414
753 902 818	414
753 902 819	414
753 902 820	414
753 902 821	414
753 902 822	414
753 902 823	414
753 902 824	414
753 902 825	414
753 902 826	414
753 902 827	414
753 902 828	414
753 902 829	414
753 902 830	414
753 902 831	414
753 902 832	414
753 902 833	414
753 902 834	414
753 902 835	414
753 902 836	414
753 902 837	414
753 902 838	414
753 902 839	414
753 902 840	414
753 902 841	414
753 902 842	414
753 902 843	414
753 902 844	414
753 902 845	414

Index

Code	Page
753 902 846	414
753 908 464	413
753 908 465	413
753 908 470	413
753 908 471	413
753 908 476	413
753 908 477	413
753 908 637	412
753 908 641	412
753 908 642	412
753 908 646	412
753 908 647	412
753 908 648	412
753 908 652	412
753 908 653	412
753 908 654	412
753 908 658	412
753 908 659	412
753 908 660	412
753 908 664	412
753 908 665	412
753 908 666	412
753 908 670	412
753 908 671	412
753 908 676	412
753 908 677	412
753 908 680	412
753 908 684	412
753 908 685	412
753 908 688	412
753 908 690	412
753 908 692	413
753 908 695	413
753 908 696	413
753 908 697	413
753 908 877	412
753 908 878	412
753 908 879	412
753 908 880	412
753 908 881	413
753 908 883	413
753 908 885	413
753 908 887	413
753 908 890	413
753 908 891	413
753 908 892	413
753 908 895	413
753 908 896	413
753 908 897	413
753 908 904	413
753 908 912	413
753 908 916	413
753 908 917	413
753 908 920	413
753 908 922	413
753 908 926	413
753 908 927	413
753 908 928	413
753 908 931	414
753 908 932	414
753 908 933	414
753 908 937	414
753 908 938	414
753 908 939	414
753 908 943	414
753 908 944	414
753 908 949	414
753 908 950	414

Code	Page
753 908 975	413
753 908 976	413
753 908 977	413
753 908 978	414
753 908 979	414
753 908 981	414
753 908 985	414
753 908 999	414
753 910 266	420
753 910 267	420
753 910 268	420
753 910 269	420
753 910 270	420
753 910 271	420
753 910 556	420
753 910 557	420
753 910 558	420
753 910 559	420
753 910 560	420
753 910 561	420
753 911 606	442
753 911 607	442
753 911 608	442
753 911 609	442
753 911 610	442
753 911 611	442
753 911 612	442
753 911 613	442
753 911 614	442
753 911 615	442
753 911 616	442
753 911 617	442
753 911 618	442
753 911 619	442
753 911 620	442
753 911 621	442
753 911 622	442
753 911 623	442
753 911 624	442
753 911 625	442
753 911 646	442
753 911 647	442
753 911 648	442
753 911 649	442
753 911 650	443
753 911 651	443
753 911 652	443
753 911 817	443
753 911 818	443
753 911 819	443
753 911 820	443
753 911 821	443
753 911 822	443
753 911 823	443
753 911 824	443
753 911 825	443
753 911 826	443
753 911 827	443
753 911 850	443
753 911 851	443
753 911 852	443
753 911 853	443
753 911 854	443
753 914 266	420
753 914 267	420
753 914 268	420
753 914 269	420
753 914 270	420

Code	Page
753 914 271	420
753 960 406	393
753 960 407	393
753 960 408	393
753 960 409	393
753 960 410	393
753 960 411	393
753 960 810	483
753 960 811	483
753 960 812	483
753 960 813	483
753 960 814	483
753 960 815	483
753 960 816	483
753 960 817	483
753 960 818	483
753 960 819	483
753 960 820	483
753 960 821	483
753 960 822	484
753 960 823	484
753 960 824	484
753 960 825	484
753 960 826	484
753 960 827	484
753 960 828	484
753 960 829	484
753 960 830	484
753 960 831	484
753 960 832	484
753 960 833	484
753 960 922	483
753 960 923	483
753 960 924	483
753 960 925	483
753 960 926	483
753 960 927	483
753 960 928	483
753 960 929	483
753 961 006	483
753 961 007	483
753 961 008	483
753 961 009	483
753 961 010	483
753 961 011	483
753 961 012	483
753 961 013	483
753 961 014	483
753 961 015	483
753 961 016	483
753 961 017	483
753 961 018	483
753 961 019	483
753 961 020	483
753 961 021	483
753 961 606	449
753 961 607	449
753 961 608	449
753 961 609	449
753 961 610	449
753 961 611	449
753 961 617	450
753 961 619	450
753 961 620	450
753 961 621	450
753 961 712	449
753 961 713	449
753 961 714	449

Index

Code	Page	Code	Page	Code	Page
753 961 715	449	790 103 048	616	790 109 337	619
753 961 716	449	790 103 059	616	790 109 338	619
753 961 717	449	790 103 060	616	790 109 339	619
753 961 718	449	790 103 061	616	790 109 340	619
753 961 719	449	790 103 062	616	790 109 341	619
753 961 720	449	790 103 063	616	790 109 342	619
753 968 606	421	790 103 064	616	790 109 343	619
753 968 607	421	790 103 065	616	790 112 098	625
753 968 608	421	790 103 066	616	790 112 099	625
753 968 609	421	790 103 067	616	790 112 100	625
753 968 610	421	790 103 068	616	790 112 101	625
753 968 611	421	790 103 080	617	790 112 102	625
761 066 796	638	790 103 081	617	790 112 103	625
761 066 797	638	790 103 085	617	790 112 104	625
775 641 502	484	790 103 086	617	790 112 105	625
775 641 507	484	790 103 090	617	790 112 106	625
775 641 510	484	790 103 099	615	790 112 107	625
775 641 514	484	790 103 160	618	790 121 002	628
775 641 518	484	790 103 161	618	790 122 091	628
775 641 524	484	790 103 162	618	790 122 092	628
775 641 632	484	790 103 163	618	790 122 093	628
775 641 636	484	790 103 164	618	790 122 094	628
775 641 640	484	790 103 165	618	790 122 095	628
775 641 641	484	790 103 166	618	790 122 096	628
775 641 645	484	790 103 167	618	790 130 002	621
775 641 655	484	790 103 168	618	790 130 003	622
775 641 659	484	790 105 052	612	790 130 004	622
775 642 664	484	790 105 053	612	790 130 031	623
775 642 665	484	790 105 054	612	790 130 032	623
775 642 666	484	790 105 055	612	790 130 033	624
775 642 669	484	790 105 059	612	790 130 034	624
775 642 672	484	790 105 060	612	790 131 005	626
775 642 673	484	790 105 061	612	790 132 001	626
775 642 675	484	790 105 062	612	790 133 009	627
775 642 678	484	790 105 081	613	790 136 001	632
790 101 086	617	790 105 082	613	790 136 002	632
790 101 087	617	790 105 083	613	790 136 003	632
790 101 088	617	790 105 084	613	790 136 004	632
790 101 089	617	790 105 085	613	790 136 005	632
790 101 090	617	790 105 086	613	790 136 006	632
790 101 091	617	790 105 087	613	790 136 007	632
790 101 092	617	790 105 088	613	790 136 008	632
790 101 093	617	790 105 096	613	790 136 009	632
790 101 094	617	790 105 098	613	790 136 010	632
790 101 095	617	790 105 126	613	790 136 011	632
790 101 098	617	790 105 128	613	790 136 012	632
790 103 010	616	790 105 136	612	790 136 013	632
790 103 011	616	790 105 137	612	790 136 014	632
790 103 019	616	790 105 138	612	790 136 015	632
790 103 020	616	790 105 139	612	790 301 000	620
790 103 021	616	790 105 140	612	790 310 034	614
790 103 022	616	790 109 001	639	799 100 061	636
790 103 023	616	790 109 002	639	799 100 062	636
790 103 024	616	790 109 003	639	799 150 007	637
790 103 025	616	790 109 011	639	799 150 008	637
790 103 026	616	790 109 012	639	799 150 009	637
790 103 027	616	790 109 013	639	799 150 090	635
790 103 031	615	790 109 303	619	799 150 378	636
790 103 033	615	790 109 321	619	799 150 382	632
790 103 039	616	790 109 327	619	799 150 385	634
790 103 040	616	790 109 328	619	799 150 386	634
790 103 041	616	790 109 329	619	799 150 387	634
790 103 042	616	790 109 330	619	799 150 388	634
790 103 043	616	790 109 331	619	799 150 389	634
790 103 044	616	790 109 332	619	799 150 390	634
790 103 045	616	790 109 333	619	799 150 391	634
790 103 046	616	790 109 335	619	799 150 392	634
790 103 047	616	790 109 336	619	799 198 012	636

Index

Code	Page
799 198 047	635
799 198 079	636
799 198 080	636
799 198 091	636
799 199 088	636
799 199 089	636
799 199 282	636
799 199 283	636
799 199 286	636
799 298 023	638
799 298 024	638
799 300 155	638
799 300 157	638
799 300 158	638
799 300 159	638
799 300 160	638
799 300 161	638
799 300 162	638
799 300 163	638
799 300 164	638
799 300 260	638
799 300 270	638
799 300 280	638
799 300 290	638
799 300 300	638
799 300 310	638
799 300 320	638
799 300 330	638
799 300 340	638
799 300 704	633
799 300 705	633
799 300 706	633
799 300 707	633
799 300 708	633
799 300 709	633
799 300 710	633
799 300 711	633
799 300 725	632
799 300 727	632
799 300 739	632
799 300 740	632
799 300 741	632
799 300 742	632
799 300 743	632
799 300 744	632
799 300 745	632
799 300 746	632
799 300 747	632
799 300 748	632
799 300 749	632
799 300 753	633
799 300 755	633
799 300 756	633
799 301 459	634
799 301 461	634
799 301 463	634
799 301 484	633
799 301 486	633
799 301 488	633
799 301 536	634
799 301 537	634
799 301 538	634
799 301 539	634
799 301 540	634
799 301 541	634
799 301 575	634
799 350 340	631
799 350 341	631

Code	Page
799 350 364	639
799 350 461	631
799 350 462	631
799 350 475	635
799 350 476	635
799 350 477	635
799 350 560	631
799 350 561	631
799 350 565	631
799 350 570	630
799 350 571	630
799 350 575	630
799 350 580	629
799 350 581	629
799 350 585	629
800 015 073	162
800 021 699	158
800 021 700	162
800 021 701	162
800 021 702	162
800 027 113	158
800 027 956	158
800 046 107	158
800 046 108	158
800 046 109	158
800 046 110	158
800 046 112	158
800 046 113	158
800 046 114	158
800 046 115	158
800 046 116	158
800 046 117	162
800 046 118	162
800 046 119	162
800 046 120	162
800 046 121	162
800 046 122	162
800 046 123	162
800 046 124	162

Worldwide at home

Our sales companies and representatives ensure local customer support in over 100 countries

www.gfps.com

Argentina / Southern South America

Georg Fischer Central Plastics Sudamérica S.R.L.
Buenos Aires, Argentina
Phone +54 11 4512 02 90
gfcentral.ps.ar@georgfischer.com
www.gfps.com/ar

Australia

Georg Fischer Pty Ltd
Riverwood NSW 2210 Australia
Phone +61 (0) 2 9502 8000
australia.ps@georgfischer.com
www.gfps.com/au

Austria

Georg Fischer Rohrleitungssysteme GmbH
3130 Herzogenburg
Phone +43 (0) 2782 856 43-0
austria.ps@georgfischer.com
www.gfps.com/at

Belgium / Luxembourg

Georg Fischer NV/SA
1070 Bruxelles/Brüssel
Phone +32 (0) 2 556 40 20
be.ps@georgfischer.com
www.gfps.com/be

Brazil

Georg Fischer Sist. de Tub. Ltda.
04571-020 São Paulo/SP
Phone +55 (0) 11 5525 1311
br.ps@georgfischer.com
www.gfps.com/br

Canada

Georg Fischer Piping Systems Ltd
Mississauga, ON L5T 2B2
Phone +1 (905) 670 8005
Fax +1 (905) 670 8513
ca.ps@georgfischer.com
www.gfps.com/ca

China

Georg Fischer Piping Systems Ltd
Shanghai 201319
Phone +86 21 3899 3899
china.ps@georgfischer.com
www.gfps.com/cn

Denmark / Iceland

Georg Fischer A/S
2630 Taastrup
Phone +45 (0) 70 22 19 75
info.dk.ps@georgfischer.com
www.gfps.com/dk

Finland

Georg Fischer AB
01510 VANTAA
Phone +358 (0) 9 586 58 25
Fax +358 (0) 9 586 58 29
info.fi.ps@georgfischer.com
www.gfps.com/fi

France

Georg Fischer SAS
95932 Roissy Charles de Gaulle Cedex
Phone +33 (0) 1 41 84 68 84
fr.ps@georgfischer.com
www.gfps.com/fr

Germany

Georg Fischer GmbH
73095 Albershausen
Phone +49 (0) 7161 302 0
info.de.ps@georgfischer.com
www.gfps.com/de

India

Georg Fischer Piping Systems Pvt. Ltd
400 083 Mumbai
Phone +91 22 4007 2000
Fax +91 22 4007 2020
branchoffice@georgfischer.com
www.gfps.com/in

Indonesia

George Fischer Pte Ltd
41371 Jawa Barat
Phone +62 267 432 044
Fax +62 267 431 857
indonesia.ps@georgfischer.com
www.gfps.com/id

Italy

Georg Fischer S.p.A.
20063 Cernusco S/N (MI)
Phone +39 02 921 861
it.ps@georgfischer.com
www.gfps.com/it

Japan

Georg Fischer Ltd
530-0003 Osaka
Phone +81 (0) 6 6341 2451
jp.ps@georgfischer.com
www.gfps.com/jp

Korea

Georg Fischer Korea Co. Ltd
Unit 2501, U-Tower
120 HeungdeokJungang-ro
(Yeongdeok-dong)
Giheung-gu, Yongin-si, Gyeonggi-do
Phone +82 31 8017 1450
Fax +82 31 217 1454
kor.ps@georgfischer.com
www.gfps.com/kr

Malaysia

George Fischer (M) Sdn. Bhd.
40460 Shah Alam, Selangor Darul Ehsan
Phone +60 (0) 3 5122 5585
Fax +60 (0) 3 5122 5575
my.ps@georgfischer.com
www.gfps.com/my

Mexico / Northern Latin America

Georg Fischer S.A. de C.V.
Apodaca, Nuevo Leon
CP66636 Mexico
Phone +52 (81) 1340 8586
Fax +52 (81) 1522 8906
mx.ps@georgfischer.com
www.gfps.com/mx

Middle East

Georg Fischer Piping Systems (Switzerland) Ltd
Dubai, United Arab Emirates
Phone +971 4 289 49 60
gcc.ps@georgfischer.com
www.gfps.com/int

Netherlands

Georg Fischer N.V.
8161 PA Epe
Phone +31 (0) 578 678 222
nl.ps@georgfischer.com
www.gfps.com/nl

Norway

Georg Fischer AS
1351 Rud
Phone +47 67 18 29 00
no.ps@georgfischer.com
www.gfps.com/no

Philippines

Georg Fischer Pte Ltd
Representative Office
Phone +632 571 2365
Fax +632 571 2368
sgp.ps@georgfischer.com
www.gfps.com/sg

Poland

Georg Fischer Sp. z o.o.
05-090 Sekocin Nowy
Phone +48 (0) 22 31 31 0 50
poland.ps@georgfischer.com
www.gfps.com/pl

Romania

Georg Fischer Piping Systems (Switzerland) Ltd
020257 Bucharest - Sector 2
Phone +40 (0) 21 230 53 80
ro.ps@georgfischer.com
www.gfps.com/int

Russia

Georg Fischer Piping Systems (Switzerland) Ltd
Moscow 125040
Phone +7 495 748 11 44
ru.ps@georgfischer.com
www.gfps.com/ru

Singapore

Georg Fischer Pte Ltd
11 Tampines Street 92, #04-01/07
528 872 Singapore
Phone +65 6747 0611
Fax +65 6747 0577
sgp.ps@georgfischer.com
www.gfps.com/sg

Spain / Portugal

Georg Fischer S.A.
28046 Madrid
Phone +34 (0) 91 781 98 90
es.ps@georgfischer.com
www.gfps.com/es

Sweden

Georg Fischer AB
117 43 Stockholm
Phone +46 (0) 8 506 775 00
info.se.ps@georgfischer.com
www.gfps.com/se

Switzerland

Georg Fischer Rohrleitungssysteme (Schweiz) AG
8201 Schaffhausen
Phone +41 (0) 52 631 3026
ch.ps@georgfischer.com
www.gfps.com/ch

Taiwan

Georg Fischer Co. Ltd
San Chung Dist., New Taipei City
Phone +886 2 8512 2822
Fax +886 2 8512 2823
www.gfps.com/tw

United Kingdom / Ireland

George Fischer Sales Limited
Coventry, CV2 2ST
Phone +44 (0) 2476 535 535
uk.ps@georgfischer.com
www.gfps.com/uk

USA / Caribbean

Georg Fischer LLC
9271 Jeronimo Road
92618 Irvine, CA
Phone +1 714 731 8800
Fax +1 714 731 6201
us.ps@georgfischer.com
www.gfps.com/us

International

Georg Fischer Piping Systems (Switzerland) Ltd
8201 Schaffhausen/Switzerland
Phone +41 (0) 52 631 3003
Fax +41 (0) 52 631 2893
info.export@georgfischer.com
www.gfps.com/int

The technical data are not binding. They neither constitute expressly warranted characteristics nor guaranteed properties nor a guaranteed durability. They are subject to modification. Our General Terms of Sale apply.